

FAST™

AG SOLUTIONS



FAST TRACK TANK GEN 4BRO INSTALLATION AND PARTS MANUAL

**8295RT, 8320RT, 8345RT
8310RT, 8335RT, 8360RT
8320RT, 8345RT, 8370RT**



FAST GLOBAL
SOLUTIONS



Table of Contents

Section	Page
Table of Contents	1
Warranty	1
Warranty Registration	2
General Information	5
Foreword	6
Safety	9
Assembly Instructions	19
Table of Contents	27
LH Tank Fitting Assembly	29
RH Tank Fitting Assembly	30
Tanks and Hardware	31
Plumbing	33
Side Tanks	35
2" Quick Fill & SRO Plumbing	37
Hanger Hardware	39
Hanger Parts	41
Sparger Plumbing	43
Rinse Out Plumbing	45
2" Quick Fill Option	47
3" Quick Fill Option	49
2" Quick Fill Valve, 45D	51
3" Quick Fill Valve, 45D	53
Def Tank Heat Shield Kit.....	55
Assembly Checklist	57



ILLUSTRATED PARTS LIST

Limited Warranty

FAST AG Solutions warrants to the buyer that the new machinery is free from defects in material and workmanship.

This warranty is only effective as to any new machinery which has not been altered, changed, repaired or treated since its delivery to the buyer, other than by FAST AG Solutions or its authorized dealers or employees, and does not apply to accessories, attachments, tools or parts, sold or operated with the new machinery, if they have not been manufactured by FAST AG Solutions.

FAST AG Solutions shall only be liable for defects in the materials or workmanship attributable to faulty material or bad workmanship that can be proved by the buyer, and specifically excludes liability for repairs arising as a result of normal wear and tear of the new machinery or in any other manner whatsoever, and without limiting the generality of the foregoing, excludes application or installation of parts not completed in accordance with this operator's manual, specifications, or printed instructions.

Written notice shall be given by registered mail, to the Manufacturer within seven (7) days after the defect shall have become apparent or the repairs shall have become necessary, addressed as follows:

FAST AG Solutions
4130 Commerce Boulevard
Windom, MN 56101

This warranty shall expire one (1) year after the date of delivery of the new machinery.

If these conditions are fulfilled, FAST AG Solutions shall at its own cost and at its own option either repair or replace any defective parts provided that the buyer shall be responsible for all expenses incurred as a result of repairs, labor, parts, transportation or any other work, unless FAST AG Solutions has authorized such expenses in advance.

The warranty shall not extend to any repairs, changes, alterations, or replacements made to the new equipment other than by FAST AG Solutions or its authorized dealers or employees.

This warranty extends only to the original owner of the new equipment.

Rubber parts (including tires, hoses, grommets) are not warranted.

This warranty is limited to the terms stated herein and is in lieu of any other warranties whether express or implied, and without limiting the generality of the foregoing, excluded all warranties, express or implied or conditions whether statutory or otherwise as to quality and fitness for any purpose of the new equipment. the Manufacturer disclaims all liability for incidental or consequential damages.

This Applicator is subject to design changes and FAST AG Solutions shall not be required to retrofit or exchange items on previously sold units except at its own option.

Warranty void if not registered.



ILLUSTRATED PARTS LIST

FAST C4T500 TRACK TANKS

Warranty Registration Form & Inspection Report

Warranty Registration

This form must be filled out by the dealer and signed by both the dealer and the customer at the time of delivery.

Customer Name				
Address				
City		State		Zip
Phone				
Dealer Name				
Address				
City		State		Zip
Applicator Model				
Serial Number				
Delivery Date				

DEALER INSPECTION REPORT

- All Fasteners Tight
- Wheel Bolts Torqued
- Hydraulic Hoses and Fittings Free and Tight
- Fertilizer Hoses and Fittings Free and Tight
- Wheel Drive Turns Freely
- Lubricate Machine
- Check Tire Pressure
- Frame and Wings Level
- Monitors and Controllers Function
- Wiring Harness Connected

SAFETY

- Safety Chain Installed
- All Guards Installed
- All Safety Signs Installed
- Reflectors, SMV and Lights Clean
- Review Operating and Safety Instructions

I have thoroughly instructed the buyer on the above described equipment which review included the Operator's Manual content, equipment care, adjustments, safe operation and applicable warranty policy.

Date _____

Dealer's Rep. Signature _____

The above equipment and Operator's Manual have been received by me and I have been thoroughly instructed as to care, adjustments, safe operation and applicable warranty policy.

Date _____

Owner's Signature _____

- White - FAST
- Yellow - Dealer
- Pink - Customer



ILLUSTRATED PARTS LIST

FAST C4T500 TRACK TANKS

TRACK TANKS SERIAL NUMBER _____

DATE PURCHASED _____ / _____ / _____

TANK SIZE _____



ILLUSTRATED PARTS LIST





ILLUSTRATED PARTS LIST

General Information

All rights, especially copying and distribution rights are reserved. No part of this publication may be reproduced in any form or by any means, electronic or mechanical, including photocopying, without express written permission from FAST AG Solutions.

Parts information in this manual represents components installed when product was manufactured based upon the best available information. Modifications made subsequent to initial delivery are not included. Always verify the parts and color required when ordering parts.

If you have any questions, please contact your FAST AG Solutions Parts and Service Department.

Explanation of Parts Lists

The parts lists are broken down sub assemblies and listed in 4 columns:

- ITEM - These numbers are found on the illustration associated with the parts list.
 - NS- This item is NOT SHOWN, included for reference.
- QTY. - This is the quantity of parts needed in an assembly.
 - AR- The quantity of this item is AS REQUIRED for the location.
- PART NO.- These are the part numbers associated to the ITEM.
- DESCRIPTION - This is the description of the part.

Foreword



READ THIS MANUAL carefully to learn how to operate and service your machine correctly. Failure to do so could result in personal injury or equipment damage. This manual and safety signs on your machine may also be available in other languages.

THIS MANUAL SHOULD BE CONSIDERED a permanent part of your machine and should remain with the machine when you sell it.

MEASUREMENTS in this manual are given in both metric and customary U.S. unit equivalents. Use only correct replacement parts and fasteners. Metric and inch fasteners may require a specific metric or inch wrench.

RIGHT-HAND AND LEFT-HAND sides are determined by facing in direction implement will travel when going forward.

WRITE PRODUCT IDENTIFICATION NUMBERS (P.I.N.) in Specification section. Accurately record all numbers to help in tracing machine should it be stolen. Your dealer also needs these numbers when you order parts. File identification numbers in a safe place off machine.

BEFORE DELIVERING THESE TANKS, your dealer performed a pre-delivery inspection.

THESE TANKS ARE DESIGNED SOLELY for use in customary agricultural or similar operations for the purpose of applying crop protection chemicals ("INTENDED USE"). Use in any other way is considered as contrary to the intended use. The manufacturer accepts no liability for damage or injury resulting from this misuse, and these risks must be borne solely by the user. Compliance with and strict adherence to the conditions of



Foreword

operation, service and repair as specified by the manufacturer also constitute essential elements for the intended use.

THESE FAST TRACK TANKS SHOULD BE OPERATED, serviced and repaired only by persons familiar with all its particular characteristics and acquainted with the relevant safety rules (accident prevention). The accident prevention regulations, all other generally recognized regulations on safety and occupational medicine and the road traffic regulations must be observed at all times. Any arbitrary modifications carried out on the FAST TRACK TANKS will relieve the manufacturer of all liability for any resulting damage or injury.

WARRANTY is provided as part of FAST's support program for customers who operate and maintain their equipment as described in this manual. Warranty is explained on warranty certificate which you should have received from your dealer.

This warranty provides you assurance that FAST will back its products where defects appear within warranty period. In some circumstances, by FAST also provides field improvements, often without charge to customer, even if product is out of warranty. Should equipment be abused, or modified to change its performance beyond original factory specifications, warranty will become void and field improvements may be denied. Setting fuel delivery above specifications or otherwise overpowering machines will result in such action.

If you are not the original owner of this machine, it is in your interest to contact your local FAST dealer to inform them of this unit's serial number. This will help FAST notify you of any issues or product improvements.



Owner Register

Name		Model Number
Post Office		P.I.N. Number
County	State	Date Purchased

Safety**Recognize Safety Information**

This is a safety-alert symbol. When you see this symbol on your machine or in this manual, be alert to the potential for personal injury.

Follow recommended precautions and safe operating practices.

Understand Signal Words

A signal word—DANGER, WARNING, or CAUTION—is used with the safety-alert symbol. DANGER identifies the most serious hazards.

DANGER or WARNING safety signs are located near specific hazards. General precautions are listed on CAUTION safety signs. CAUTION also calls attention to safety messages in this manual.

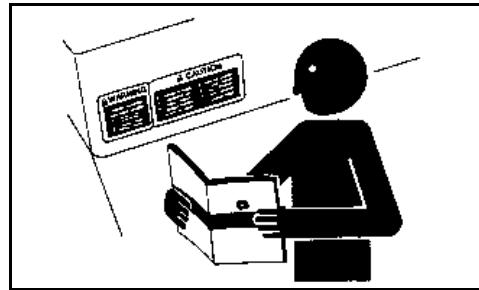
Follow Safety Instructions

Carefully read all safety messages in this manual and on your machine safety signs. Keep safety signs in good condition. Replace missing or damaged safety signs. Be sure new equipment components and repair parts include the current safety signs. Replacement safety signs are available from your FAST dealer.

There can be additional safety information contained on parts and components sourced from suppliers that is not reproduced in this operator's manual.

Learn how to operate the machine and how to use controls properly. Do not let anyone operate without instruction.

Keep your machine in proper working condition. Unauthorized modifications to the machine may impair the function and/or safety and affect machine life.

If you do not understand any part of this manual and need assistance, contact your FAST dealer.

Prepare for Emergencies

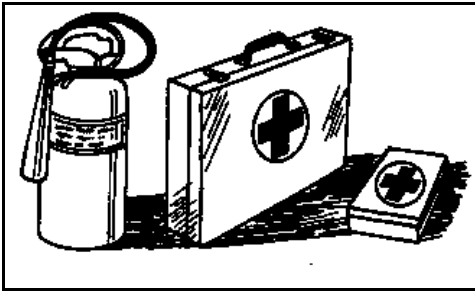

Be prepared if a fire starts.

Keep a first aid kit and fire extinguisher handy.

Keep emergency numbers for poison control center, doctors, ambulance service, hospital, and fire department near your telephone.

Protect Against Noise

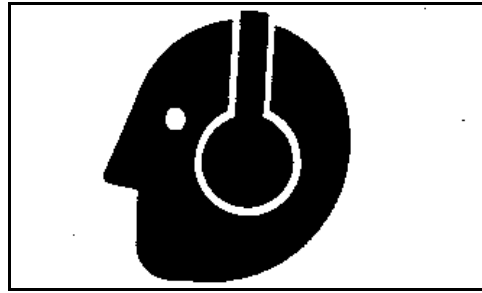

Prolonged exposure to loud noise can cause impairment or loss of hearing.

Wear a suitable hearing protective device such as earmuffs or earplugs to protect against objectionable or uncomfortable loud noises.

Wear Protective Clothing

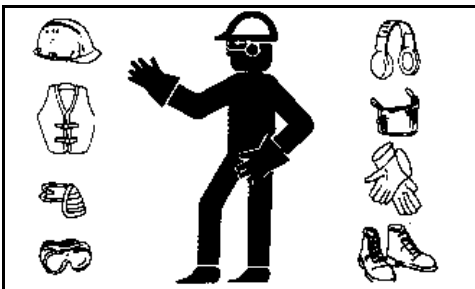

Wear close fitting clothing and safety equipment appropriate to the job.

Operating equipment safely requires the full attention of the operator. Do not wear radio or music headphones while operating machine.

Practice Safe Maintenance



Understand service procedure before doing work. Keep area clean and dry.

Never lubricate, service, or adjust machine while it is moving. Keep hands, feet, and clothing from power-driven parts. Disengage all power and operate controls to relieve pressure. Lower equipment to the

ground. Stop the engine. Remove the key. Allow machine to cool.

Securely support any machine elements that must be raised for service work.

Keep all parts in good condition and properly installed. Fix damage immediately. Replace worn or broken parts. Remove any buildup of grease, oil, or debris.

On self-propelled equipment, disconnect battery ground cable (-) before making adjustments on electrical systems or welding on machine.

On towed implements, disconnect wiring harnesses from tractor before servicing electrical system components or welding on machine.

Support Raised Equipment



Always use a safety support when working on, under, or around machine. Transport/Service locks can be used for this purpose.

Shut off tractor engine and remove key when working on machine.

If air has been allowed to enter hydraulic hoses or cylinders, bleed hydraulic system before use. If there is a failure in hydraulic system, unsupported raised equipment could suddenly lower, causing serious personal injury or death.

If support is not available, completely lower wings and frame, relieve hydraulic pressure and disconnect hoses from tractor.

Avoid Heating Near Pressurized Fluid Lines

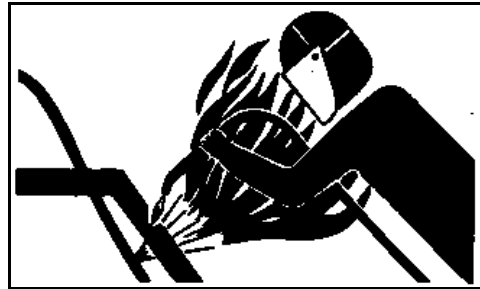

Flammable spray can be generated by heating near pressurized fluid lines, resulting in severe burns to yourself and bystanders. Do not heat by welding, soldering, or using a torch near pressurized fluid lines or other flammable materials. Pressurized lines can accidentally burst when heat goes beyond the immediate flame area.

Avoid High-Pressure Fluids



Inspect hydraulic hoses periodically – at least once per year – for leakage, kinking, cuts, cracks, abrasion, blisters, corrosion, exposed wire braid or any other signs of wear or damage.

Replace worn or damaged hose assemblies immediately with FAST approved replacement parts.

Escaping fluid under pressure can penetrate the skin causing serious injury.

Avoid the hazard by relieving pressure before disconnecting hydraulic or other

lines. Tighten all connections before applying pressure.

Search for leaks with a piece of cardboard. Protect hands and body from high-pressure fluids.

If an accident occurs, see a doctor immediately. Any fluid injected into the skin must be surgically removed within a few hours or gangrene may result. Doctors unfamiliar with this type of injury should reference a knowledgeable medical source.

Inspect Lift Circuit Hoses

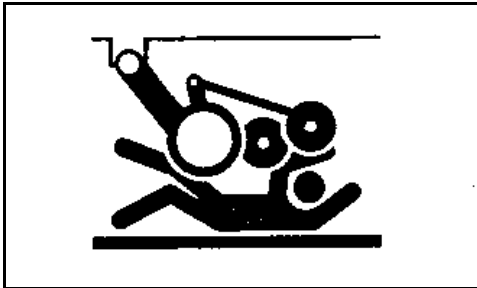

Avoid serious injury or death while working under a raised implement.

Hydraulic hoses between the lift cylinders and hydraulic lock-up valves should be inspected frequently for leakage, kinking, cuts, cracks, abrasion, blisters, corrosion, exposed wire braid or any other signs of wear or damage. Worn or damaged hose assemblies can fail during use and should be replaced immediately. See your FAST dealer for replacement hoses.

Store Attachments Safely

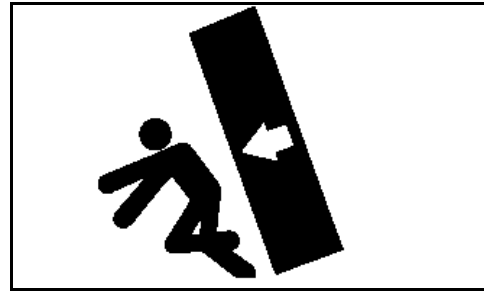

Stored attachments such as dual wheels can fall and cause serious injury or death.

Securely store attachments and implements to prevent falling. Keep playing children and bystanders away from storage area.

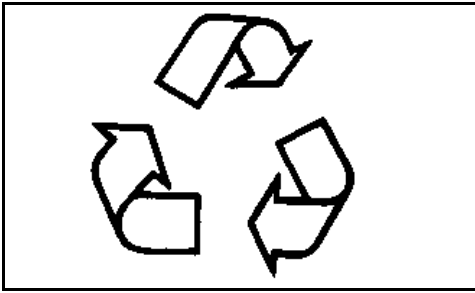
Dispose of Waste Properly

Improperly disposing of waste can threaten the environment and ecology. Potentially harmful waste used with equipment include such items as oil, fuel, coolant, brake fluid, filters, and batteries.

Use leakproof containers when draining fluids. Do not use food or beverage containers that may mislead someone into drinking from them.

Do not pour waste onto the ground, down a drain, or into any water source.

Air conditioning refrigerants escaping into the air can damage the Earth's atmosphere. Government regulations may require a certified air conditioning service center to recover and recycle used air conditioning refrigerants.

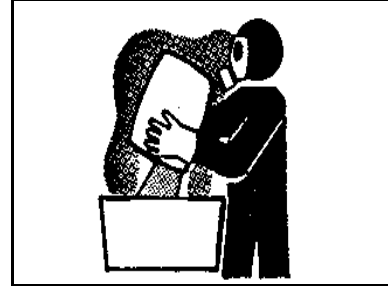
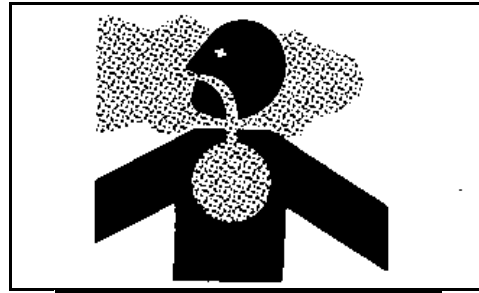
Handle Agricultural Chemicals Safely

Chemicals used in agricultural applications such as fungicides, herbicides, insecticides, pesticides, rodenticides, and fertilizers can be harmful to your health or the environment if not used carefully.

Always follow all label directions for effective, safe, and legal use of agricultural chemicals.

Reduce risk of exposure and injury:

Wear appropriate personal protective equipment as recommended by the manufacturer. In the absence of manufacturer's instructions, follow these general guidelines:

Chemicals labeled 'Danger': Most toxic. Generally require use of goggles, respirator, gloves, and skin protection.

Chemicals labeled 'Warning': Less toxic. Generally require use of goggles, gloves, and skin protections.

Chemicals labeled 'Caution': Least toxic. Generally require use of gloves and skin protection.

Avoid inhaling vapor, aerosol or dust.

Always have soap, water, and towel available when working with chemicals. If chemical contacts skin, hands, or face, wash immediately with soap and water. If chemical gets into eyes, flush immediately with water.

Wash hands and face after using chemicals and before eating, drinking, smoking, or urination.

Do not smoke or eat while applying chemicals.

After handling chemicals, always bathe or shower and change clothes. Wash clothing before wearing again.

Seek medical attention immediately if illness occurs during or shortly after use of chemicals.

Keep chemicals in original containers. Do not transfer chemicals to unmarked containers or to containers used for food or drink.

Store chemicals in a secure, locked area away from human or livestock food. Keep children away.

Always dispose of containers properly. Triple rinse empty containers and puncture or crush containers and dispose of properly.

Handle Chemical Products Safely

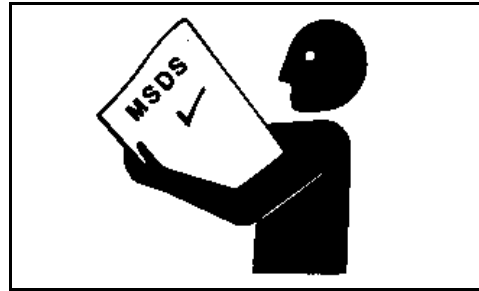

Direct exposure to hazardous chemicals can cause serious injury. Potentially hazardous chemicals used with FAST equipment include such items as lubricants, coolants, paints, and adhesives.

A Material Safety Data Sheet (M/SDS) provides specific details on chemical products: physical and health hazards, safety procedures, and emergency response techniques.

Check the M/SDS before you start any job using a hazardous chemical. That way you will know exactly what the risks are and how to do the job safely. Then follow procedures and recommended equipment.

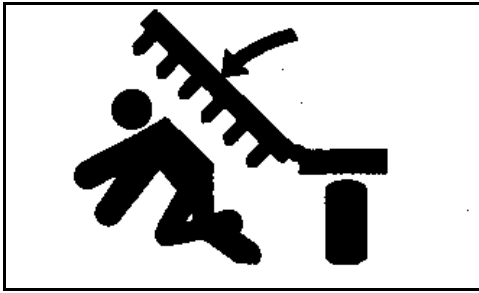
Operate Safely

Before operating, make sure air has been bled from wing-fold hydraulic system.

Be sure area around machine is clear before raising or lowering machine frame or wings.

Do not operate close to the edge of a ditch, creek, gully or steep embankment.

Avoid holes, ditches and obstructions which may cause tractor, machine, or towed equipment to roll over, especially on hillsides.

Avoid sharp turns on hillsides.

Slow down when turning or traveling over rough ground, and when turning on inclines.

Always shut off tractor and shift to PARK or set brakes when leaving tractor. Remove key when leaving tractor unattended.

Always have tractor stopped on level ground when raising or lowering wings.

Operate machine from tractor seat only.

If chemicals are used, follow manufacturer's recommendations for handling and storage.

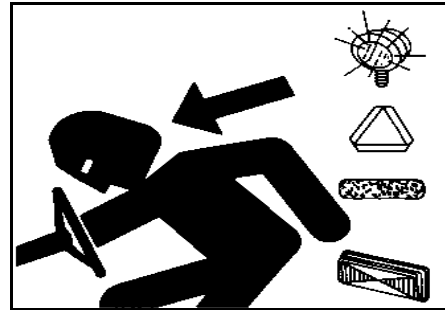
Use Safety Lights and Devices

Prevent collisions between other road users, slow moving tractors with attachments or towed equipment, and self-propelled machines on public roads. Frequently check for traffic from the rear, especially in turns, and use turn signal lights.

Use headlights, flashing warning lights, and turn signals day and night. Follow local regulations for equipment lighting and marking. Keep lighting and marking visible, clean, and in good working order. Replace or repair lighting and marking that has been damaged or lost.

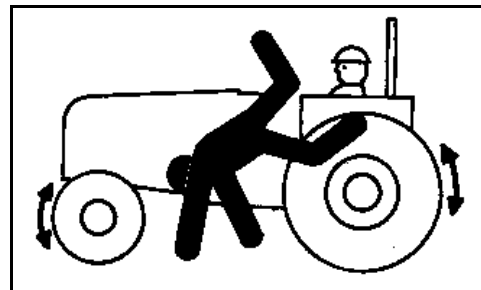
Keep Riders Off Machine

Only allow the operator on the machine. Keep riders off.

Riders on machine are subject to injury such as being struck by foreign objects and being thrown off of the machine. Riders also obstruct the operator's view resulting in the machine being operated in an unsafe manner.

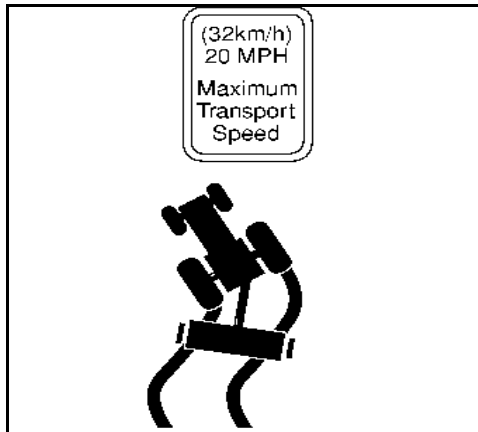
Observe Maximum Transport Speed

 **CAUTION:** Be sure all bystanders are clear of equipment.

IMPORTANT: Transport only with tanks **EMPTY** to prevent equipment damage.

Some tractors are capable of operating at speeds that exceed the maximum transport speed of this implement. Regardless of the maximum speed capability of the tractor being used to tow this implement, do not exceed the implement's maximum transport speed.

Exceeding the implement's maximum transport speed can result in:

Loss of control of the tractor/implement combination

Reduced or no ability to stop during braking

Implement tire failure

Damage to the implement structure or its components

Use additional caution and reduce speed when towing under adverse surface conditions, when turning, and when on inclines.

EC Compliance Notification

 **WARNING:** Environmental transportation hazard. A loaded machine driven on public roads has a high risk of tire failure. Do not use the machine for transporting product on public roads.

Never transport with the tank filled with water or chemical.

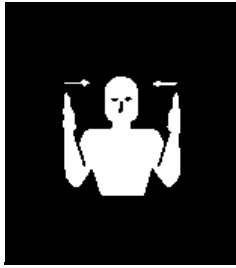
Use a Signal Person

Use a signal person to direct movement of the tractor, whenever the tractor operator's view is obstructed.

Designate one individual as THE signal person. Always have signal person stand in clear view. Be sure signal person stays a safe distance away from the machine when it is moving.

Prior to starting the tractor, discuss hand signals and what each signal means to avoid misunderstandings and confusion which could result in a serious injury or fatal accident for someone.

Keep all bystanders away whenever the machine is moved.

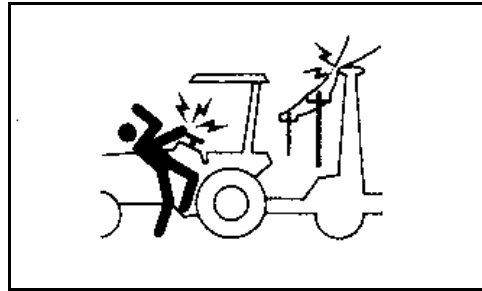
Avoid Overhead Power Lines

CAUTION: Keep away from overhead power lines. Serious injury or death may result. Proceed cautiously under overhead power lines and around utility poles. Know the transport height of your machine. Electrocution can occur without direct contact with overhead electrical lines.

Prepare for Transport

 **CAUTION: Avoid serious injury or death to your or others.**

Be aware of height and width restrictions to avoid collision with overpasses or other road users.



Latch the tractor brakes together.

IMPORTANT: Do not transport on a roadway unless machine is equipped with proper functioning lights and reflective marking/emblems. Ensure that the lights and reflective marking/emblems are clean and visible. Contact your FAST dealer for lights and lighting harnesses.

Always follow local and national regulations for equipment size, lighting and marking before driving on public roadways. You are responsible for understanding and complying with all requirements regarding roadway transport. Refer to **USE SAFETY LIGHTS AND DEVICES** (in this section).

Safety Sign Locations

Safety signs on machine are shown in the following illustrations. Familiarize yourself with safety signs, type of warning and area, or particular function related to that area, that requires your **SAFETY AWARENESS**.

 DANGER		
		
CHEMICAL HAZARD <i>To prevent serious injury or death:</i>		
WEAR RUBBER GLOVES	DON'T BREATHE VAPOR	DON'T INGEST CHEMICAL
<ul style="list-style-type: none"> Do not allow chemical or solution to touch skin. Some can be absorbed through the skin. Wear rubber gloves and protective gear at all times. 	<ul style="list-style-type: none"> Stay away from chemical splash and vapor. Keep others away. Do not breathe vapor. Wear Proper respirator when working with chemicals 	<ul style="list-style-type: none"> Chemicals can be toxic. If in eyes or mouth, read chemical manufacturers' instructions and follow them exactly. Seek medical attention immediately. A poison control number is normally inside the front cover of your telephone book. 800007



Assembly Instructions

Upon arrival, the FAST 4BRO Track Tanks require initial installation.

Unpack and inspect all parts for damaged or missing components.

Review and follow all safety instructions in this manual.

Read and understand the Assembly Instructions before beginning.

Gather tools needed for assembly.

Contact FAST AG Solutions with questions or for clarification.



The assembly of this equipment requires a minimum of two (2) people.

Wear appropriate PPE when assembling this equipment.

Do not place any part of your body under lifted or suspended components.

Be sure components are securely attached with all required hardware before removing lifting or supporting equipment.

Tools Required for Assembly

Equipment:

Lifting equipment
Jack Stands

Tools

Full Set of Wrenches from 5/16" - 1-1/8"
Torque Wrenches: 0 - 10 N-m (0 - 50 in-lbs)
0 - 400 N-m (0 - 300 ft-lbs)
Needle Nose Pliers
Dead Blow Hammer
Aligning Pry Bars
Flat Head Screwdriver

The color of the equipment or components in the photos may vary from your equipment, however the process for assembly is the same.

Remove Hydraulic Filter Cover, Step Assembly And Tool Box

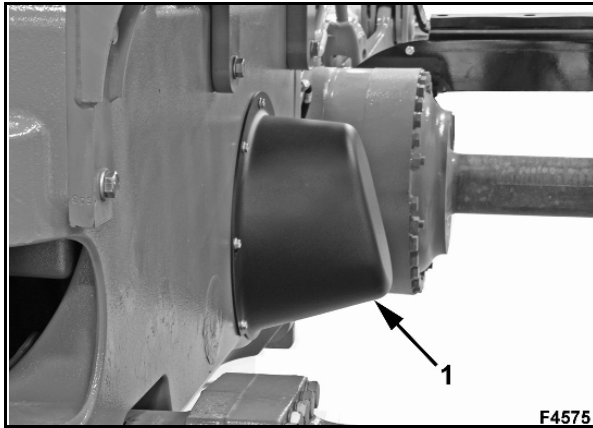

1. Remove hydraulic filter cover (1) and set aside. Cover will not be re-installed with tanks installed on tractor.

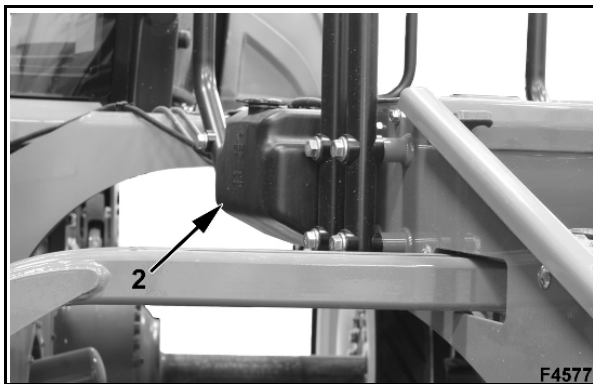

2. Remove hardware from windshield reservoir (2) mounting bracket and railing so reservoir can be moved out of the way. Save all hardware to be reused.



3. Tractor with DEF Fill only, Remove hardware from DEF fill bracket and save for reuse



WARNING

Step assembly weighs approximately 300 lbs. Use an appropriate lifting device to prevent injury.

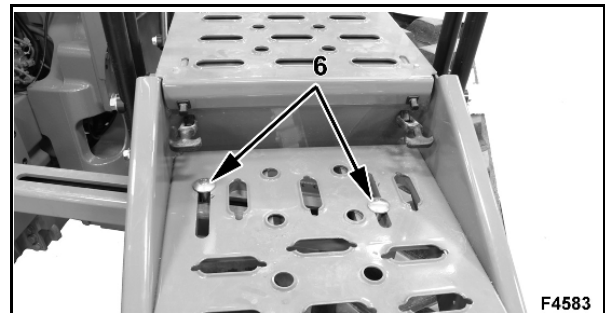
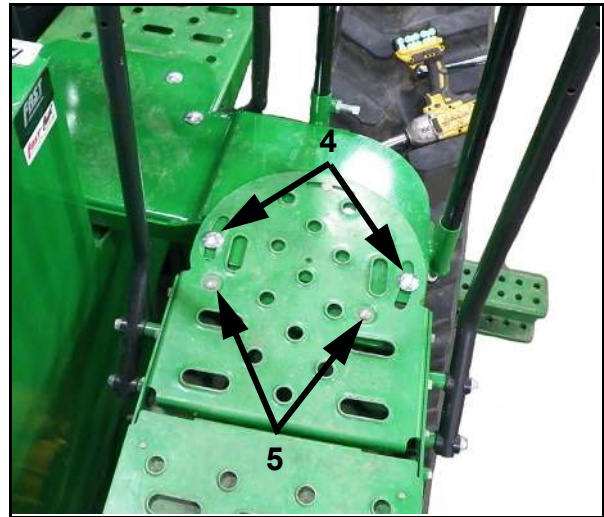

4. Attach lifting device to step assembly.
5. Remove nuts, washers and carriage bolts (4), (5) and (6). Save nuts, washers and carriage bolts (5) for reuse.

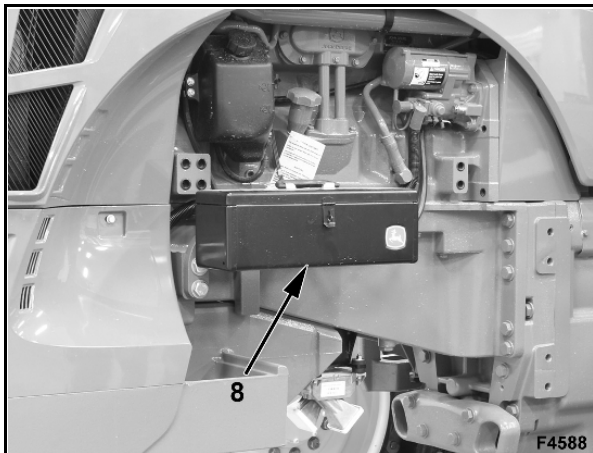
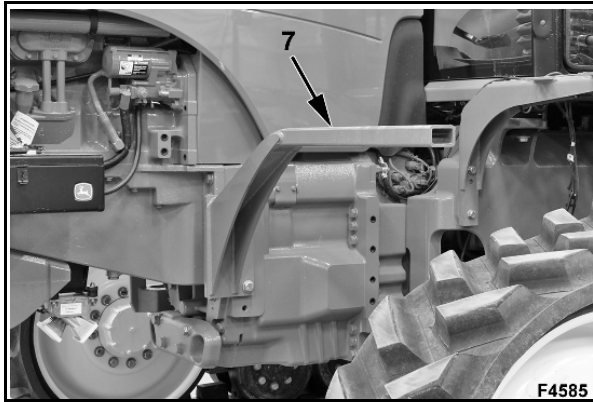

7. Remove tool box (8) from bracket. Tool box bracket does not need to be removed.

Remove Center Link Bracket And Radar

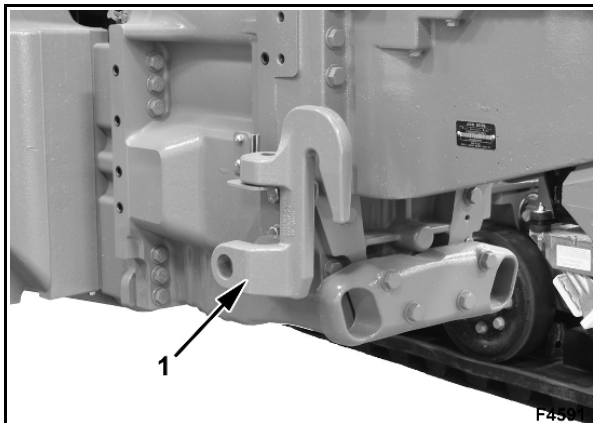

1. Remove center link (1) and mounting bracket from right hand side of tractor.

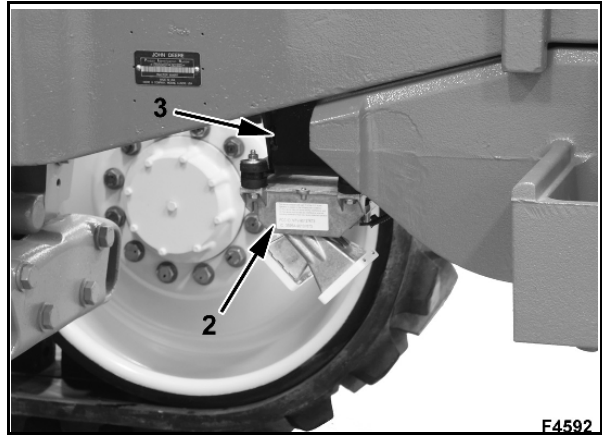

2. Disconnect radar harness from radar (2). Remove radar from mounting bracket (3). Save hardware for reuse. Remove radar mounting bracket (3).

Install Rear Tank Supports

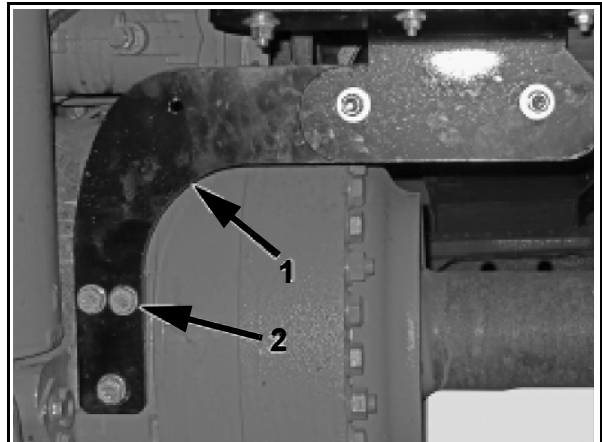

1. Install right hand tank mount (1) with three M16 x 40mm GR8.8 bolts and three M16 flat washers. Repeat on left side using left hand tank mount, three M16 x 40mm GR8.8 bolts and three M16 flat washers.

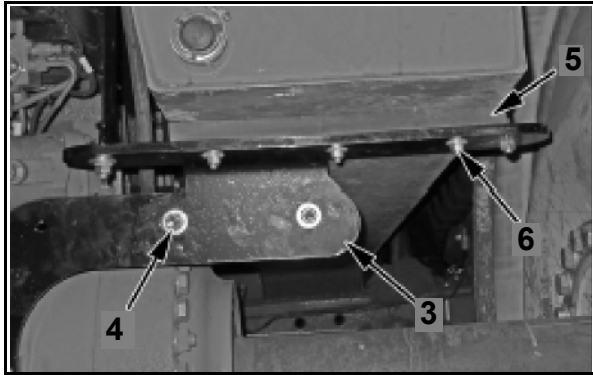

Note: For Ultra Wide Gauge tractor, brackets (1) and (3) are reversed.

2. Install tank support (3) with two ½ X 1-½" bolts (4), ½" washers and ½" nylock nuts. Do not fully tighten as bracket will need to be adjusted when tanks are installed later.

3. Install rubber isolator (5) with three ½ x 1-½" bolts (6) and three ½" centerlock nuts. Snug bolts to slightly compress rubber. Repeat procedure for left hand side.

Install Receiver Mounting Brackets



WARNING

Receiver mounting bracket weighs approximately 105 lbs. Use an appropriate lifting device to prevent injury.

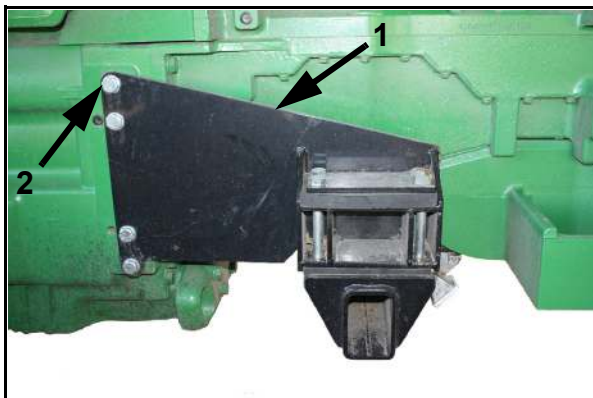

1. Install left-side mounting bracket (1) to tractor with M20 x 60mm GR 10.9 bolts (2) and M20 flat washers. Refer to torque charts in this instruction for bolt torque values.

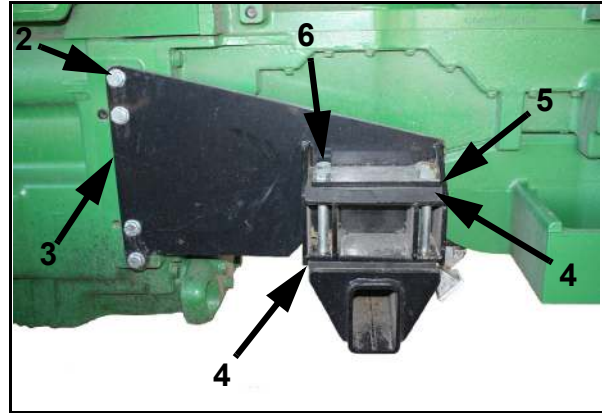

2. Install right-side mounting bracket (3) to tractor with M20 x 60mm GR 10.9 bolts (2) and M20 flat washers. Refer to torque charts in this instruction for bolt torque values.

3. Place rubber isolators (4) on top and bottom of bracket.

4. Place plate (5) on top of isolator and insert four ¾ x 9" GR5 bolts (6) through plate and both isolators.

5. Repeat steps 3 and 4 for left-hand side receiver mounting bracket.

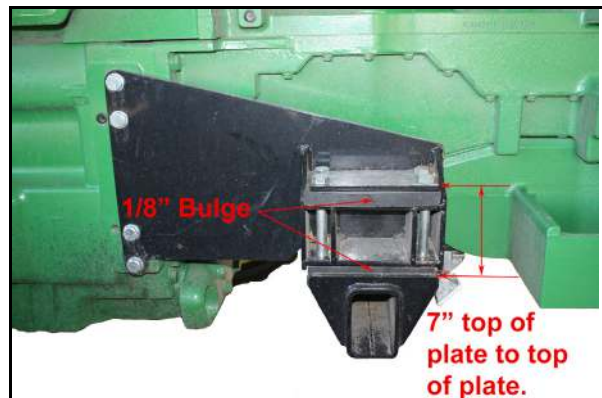

6. Tighten bolts (6) until the rubber pad (4) squeezes out about 1/8" on each side.

7. The plates should measure 7" top of plate to top of plate.



WARNING

Receiver mounting tube weighs approximately 105 lbs. Use an appropriate lifting device to prevent injury.

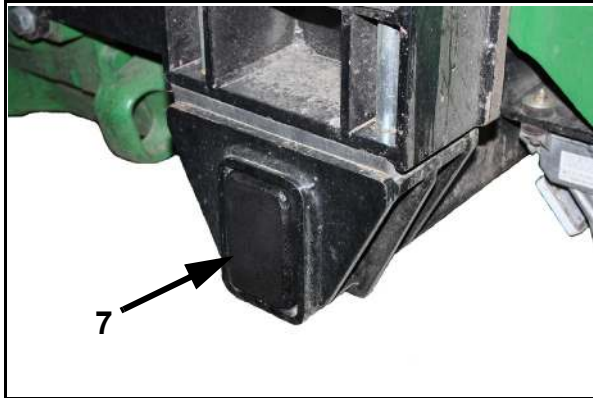

6. Raise receiver mounting tube (7) into position with radar bracket facing forward and install eight $\frac{3}{4}$ " centerlock nuts. Tighten all eight bolts equally so some bulge is seen on the rubber isolators.

Install Setscrews

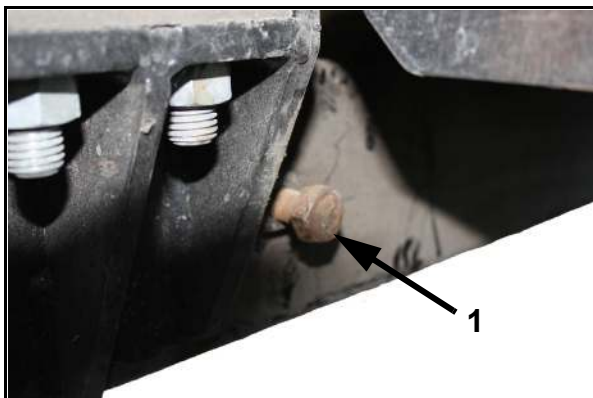

1. Install four setscrews (1) in receiver tube. Verify setscrews do not extend inside tubes.

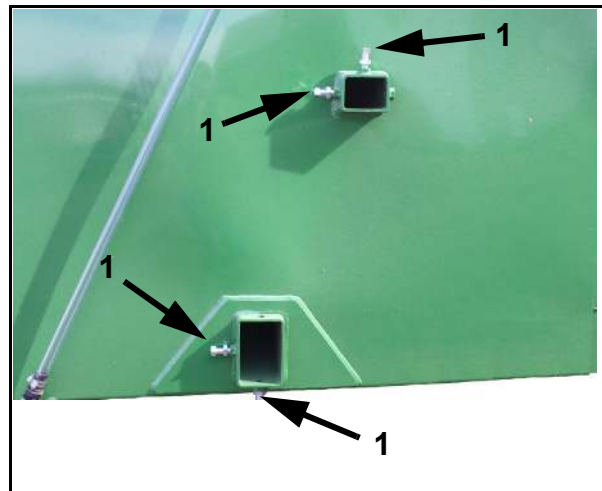

2. Install two setscrews (1) in each receiver on left and right-hand tanks. Verify setscrews do not extend inside tubes.

Install Radar

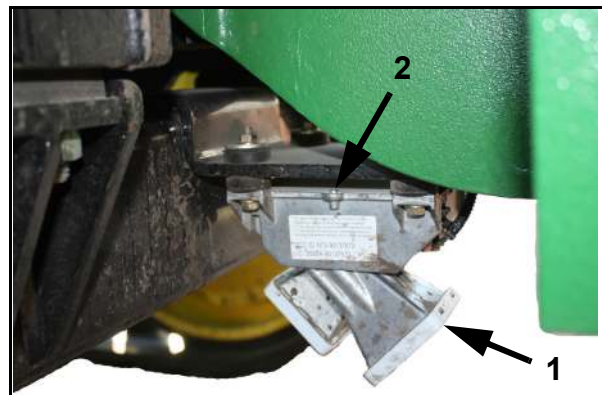

1. Attach radar (1) to mounting bracket (2) with existing hardware.

Install Tanks

WARNING

Each tank weighs approximately 1100 lbs. Use an appropriate lifting device to prevent injury.

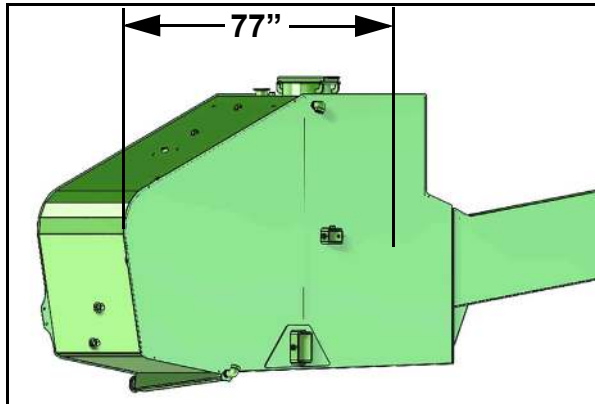

1. Connect an appropriate lifting device to left hand tank. Tank will balance when strap is 77" from front.

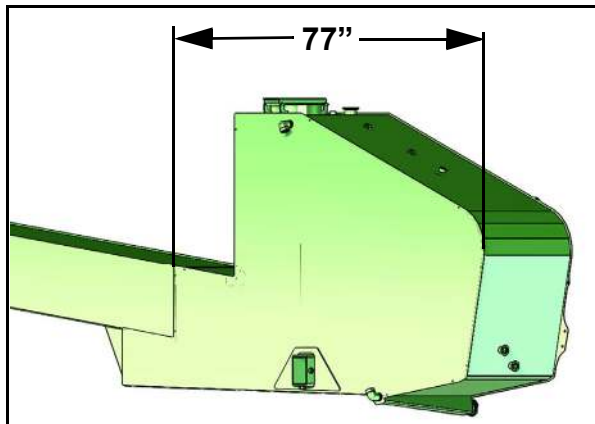

2. Connect an appropriate lifting device to right hand tank. Tank will balance when strap is 77" from front.



Typical Lifting Device

3. Raise tank and guide into position on rear support bracket (1).



4. Align tank receiver with front receiver and insert tube (2) through tank and into front receiver.

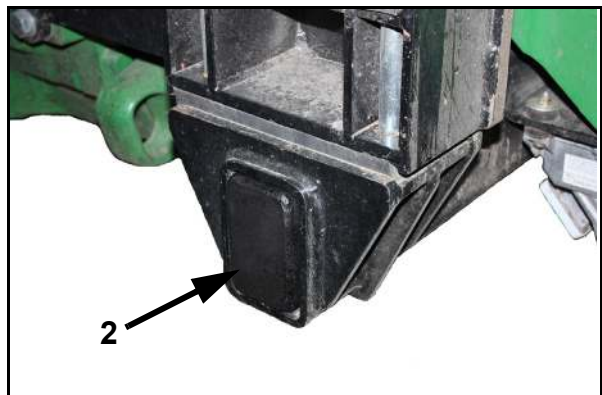

5. Verify that tube (2) does not extend past front receiver on right-hand side of tractor.

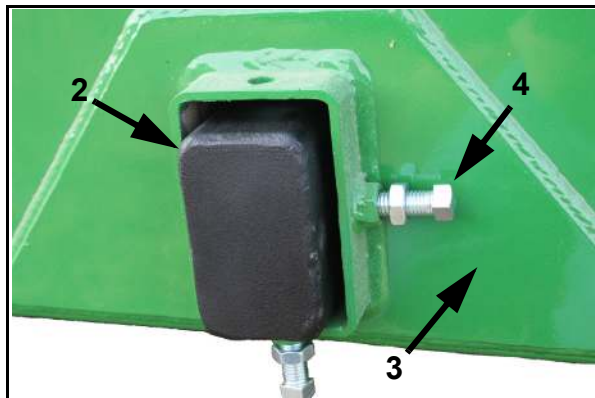

6. Install right-hand side tank using steps 1 and 2.
7. With right-hand tank (3) aligned with front receiver, push tube (2) through right-hand tank.
8. Push both tanks inward against front receiver and tighten eight setscrews (4) on front receiver and outside of both tanks. Refer to torque charts in this instruction for bolt torque values.
9. Disconnect lifting devices.

Install Straps And Nylon Protector

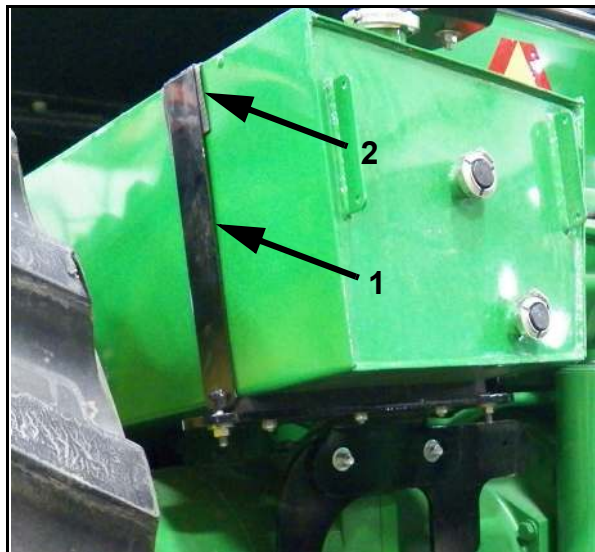

1. Position strap (1) into place and insert nylon web (2) between strap and tank. Insert studs on straps through holes in tank supports. Place two 1/2" washers and two nylock nuts on studs and tighten only

enough to keep nylon web in place and tank from moving side to side. Now tighten the bolts (see Page 5, step 2) that hold the tank support to the tank mounts. Repeat procedure on left side.

Install Windshield Washer Reservoir And DEF Fill Bracket

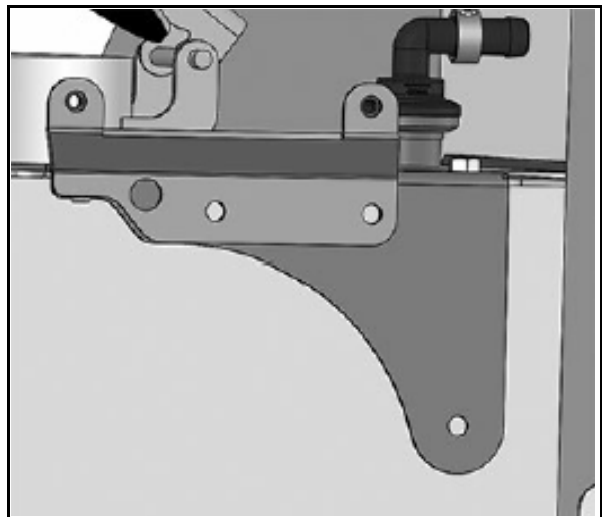

1. Install windshield washer reservoir with supplied hardware, remount windshield washer reservoir bracket and mount reservoir with hardware removed earlier.

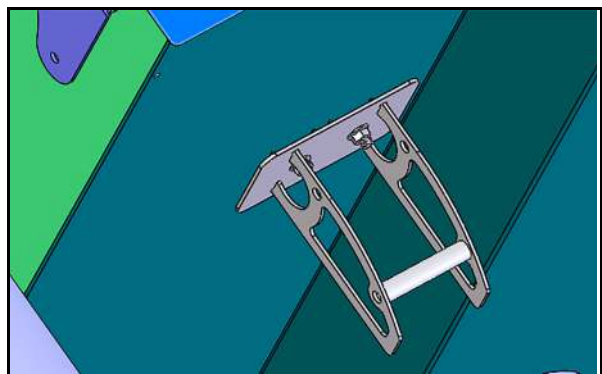

2. Bolt DEF Support bracket in place using two 592 carriage bolt 3/8 x 1 and two 769 3/8" nylock nuts. Reinstall DEF Fill with hardware removed earlier.

Install Step Assembly

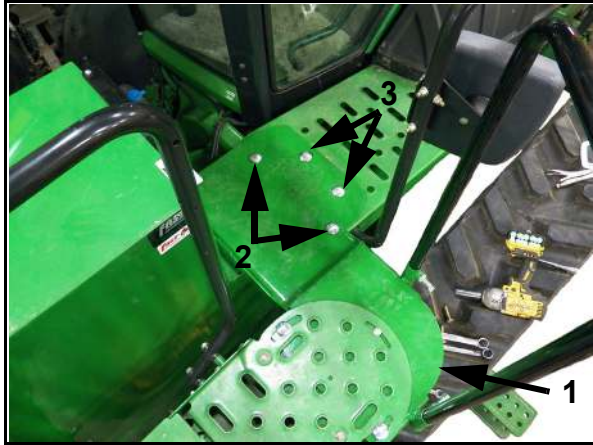

1. Install top step bracket (1) with four 5/8 x 1.5" carriage bolts (2) and (3), and flange nuts. Refer to torque charts in this instruction for bolt torque values.

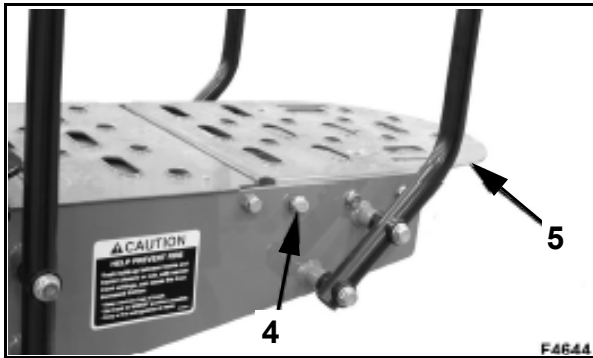

2. Remove six bolts (4) and existing top step. Install new top step and attach with six bolts previously removed. Refer to torque charts in this instruction for bolt torque values.

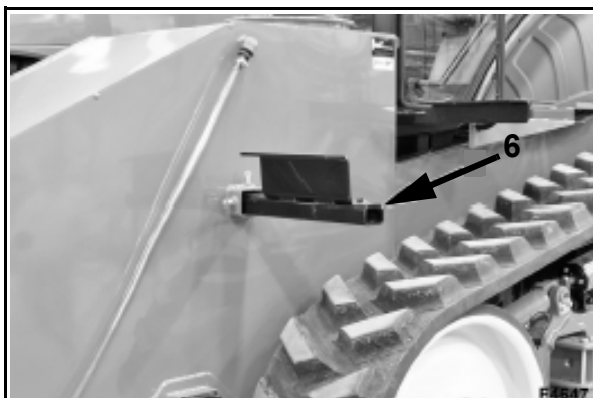

3. Install step support tube (6) as shown into receiver on left-hand tank. Do not tighten setscrews at this time.



WARNING

Step assembly weighs approximately 300 lbs. Use an appropriate lifting device to remove step assembly.



4. Attach lifting device to step assembly.
5. Raise step assembly into position and attach to top bracket (1) with 5/8 x 1.5" carriage bolts (7) and 5/8" lock washers and nuts.

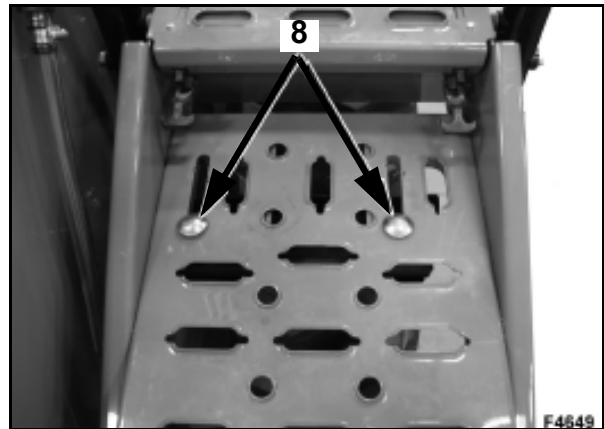

6. Attach to support tube with existing carriage bolts (8) and flange nuts.
7. Adjust step and tighten all step hardware and setscrews. Refer to torque charts in this instruction for bolt torque values.



ILLUSTRATED PARTS LIST

Table of Contents

Section	Page
Table of Contents	27
LH Tank Fitting Assembly	29
RH Tank Fitting Assembly	30
Tanks and Hardware	31
Tanks and Hardware With Rinse Out	33
Tanks and Hardware With Rinse Out	35
Riser Assembly With Check Valve	37
Plumbing	39
Side Tanks	41
2" Quick Fill & SRO Plumbing	43
Hanger Hardware	45
Hanger Parts	47
Agitation / Rinse Out Plumbing	49
2" Quick Fill Option	51
3" Quick Fill Option	53
2" Quick Fill Valve, 45D	55
3" Quick Fill Valve, 45D	57
Def Tank Heat Shield Kit	59



ILLUSTRATED PARTS LIST



LH Tank Fitting Assembly



RH Tank Fitting Assembly





ILLUSTRATED PARTS LIST

Tanks and Hardware

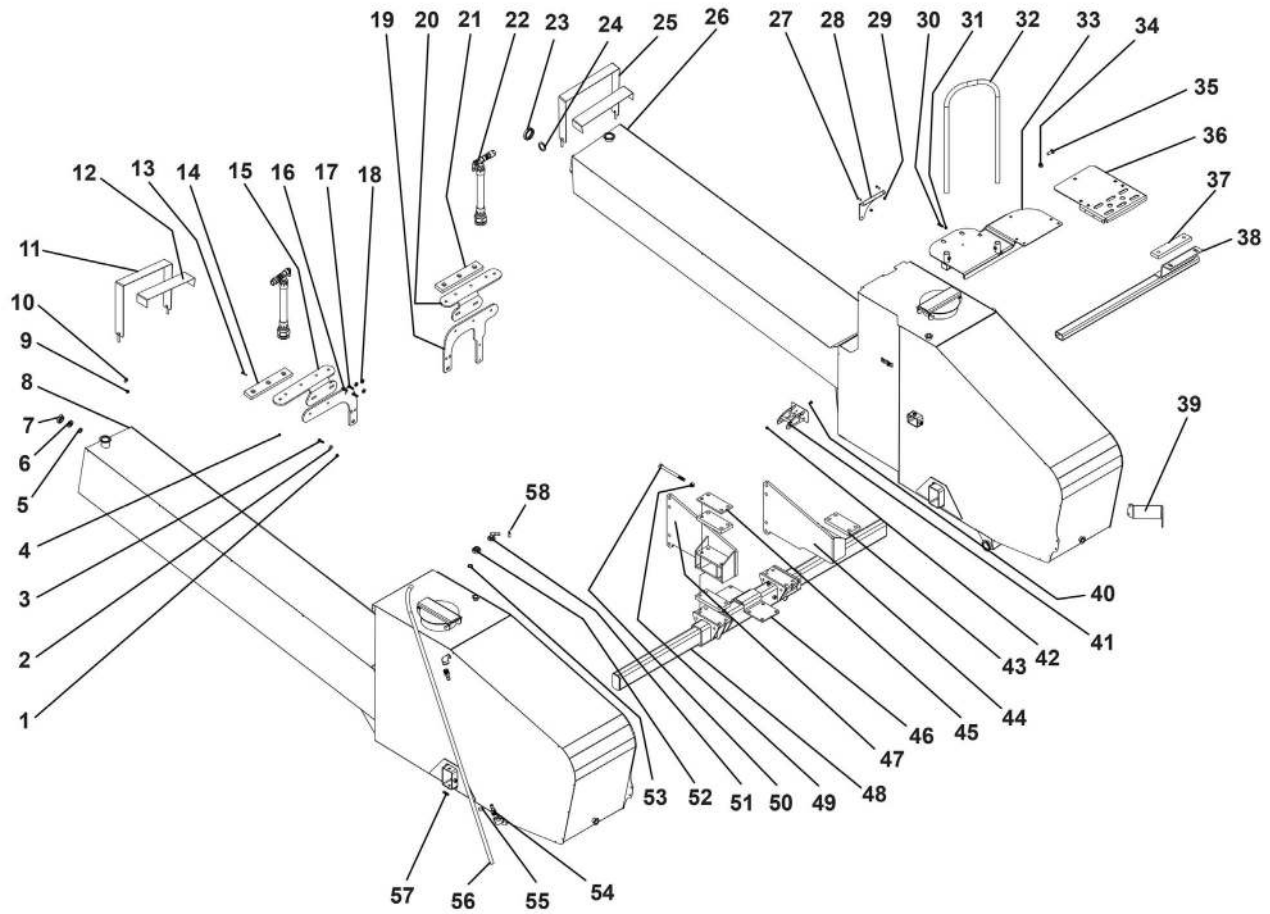



ILLUSTRATED PARTS LIST

Tanks and Hardware Parts List

ITEM	PART NO.	QTY.	DESCRIPTION
1	239	4	Nut Centerlock 1½" Zp
2	260	6	Washer ½" Zp
3	153	6	Bolt Hex Head ½ X 1-½ Zp Gr5
4	237	6	Nut Centerlock 3/8 ½" Zp
5	530068	4	Gasket Manifold 1"
6	540000	4	Clamp Manifold 1"
7	530070	2	Plug Manifold 1"
8	25000	1	Tank Track JD Right 4B
9	239	4	Nut Centerlock ½" Zp
10	260	4	Washer ½ Zp
11	19938	1	Strap Tie Down SS
12	19340	2	Web Nylon 4" Anti-Wear
13	129	6	Bolt Hex Head 3/8 X 1-½ Zp Gr5
14	14894	1	Isolator Rubber 4G
15	19337R	1	Tank Support Right Rear 4G
16	28170	1	Tank Mount Rear Right 4G
17	590141	6	Bolt Hex Head 16mm X 40mm Gr. 8.8
18	551	6	Washer Lock 16mm
19	28171	1	Tank Mount Rear Left 4G
20	19337L	1	Tank Support Left Rear 4G
21	14894	1	Isolator Rubber 4G
22	10216	2	Riser Assembly
23	540002	2	Clamp Manifold 2" Full Port
24	530019	2	Gasket Manifold 2" Full Port
25	19338	1	Strap Tie Down SS
26	25015	1	Tank Track JD Left 4B
27	127	2	Bolt Hex Head 3/8 X 3/4 Gr5 Zp
28	19934	1	Bracket Windshield Washer Reservoir
29	769	2	Nut, Flange 3/8 Zp
30	779	2	Setscrew ½ X 1-½ Zp
31	224	2	Nut Hex , Jam 5/8 Zp
32	14932	1	Hand Rail
33	28621	1	JD 4G Platform Extension
34	590092	3	Bolt Carraige 5/8 X 1-½ Zp
35	772	3	Nut Whizlock 5/8"
36	14578	1	Jd Top Step
37	14547	1	Isolator Rubber Step
38	19919	1	Bracket Step
39	25027	1	Mount Quick Fill
40	592	2	Bolt Carriage 3/8 X 1
41	19921	1	Mount Def Fill
42	769	2	Nut, Flange 3/8 Zp
43	5333	4	Isolator Rubber Receiver Cross Tube
44	14898L	1	Mount Front Left 4G
45	5289	2	Plate Rubber Isolator
46	14899	1	Receiver Cross Tube
47	14898R	1	Mount Front Right 4G
48	14554	1	Receiver Cross Tube
49	241	8	Nut NYLOCK 3/4" Zp
50	590147	8	Bolt Hex Head 3/4 X 9 Zp Gr5
51	530104	2	2.00 FP Elbow X 2.00 HB
52	540002	2	2.00 Clamp
53	530019	2	2.00 Gasket
54	530043	4	Hose Barb 1" Npt X 3/4 HB
55	540013	4	Clamp Hose 3/4"
56	510006	2	Hose Vinyl 3/4" X Specify Feet
57	590295	14	Setscrew 5/8 X 2" ZP
58	540007	2	2.00 T-Bolt Hose Clamp

Tanks and Hardware With Rinse Out

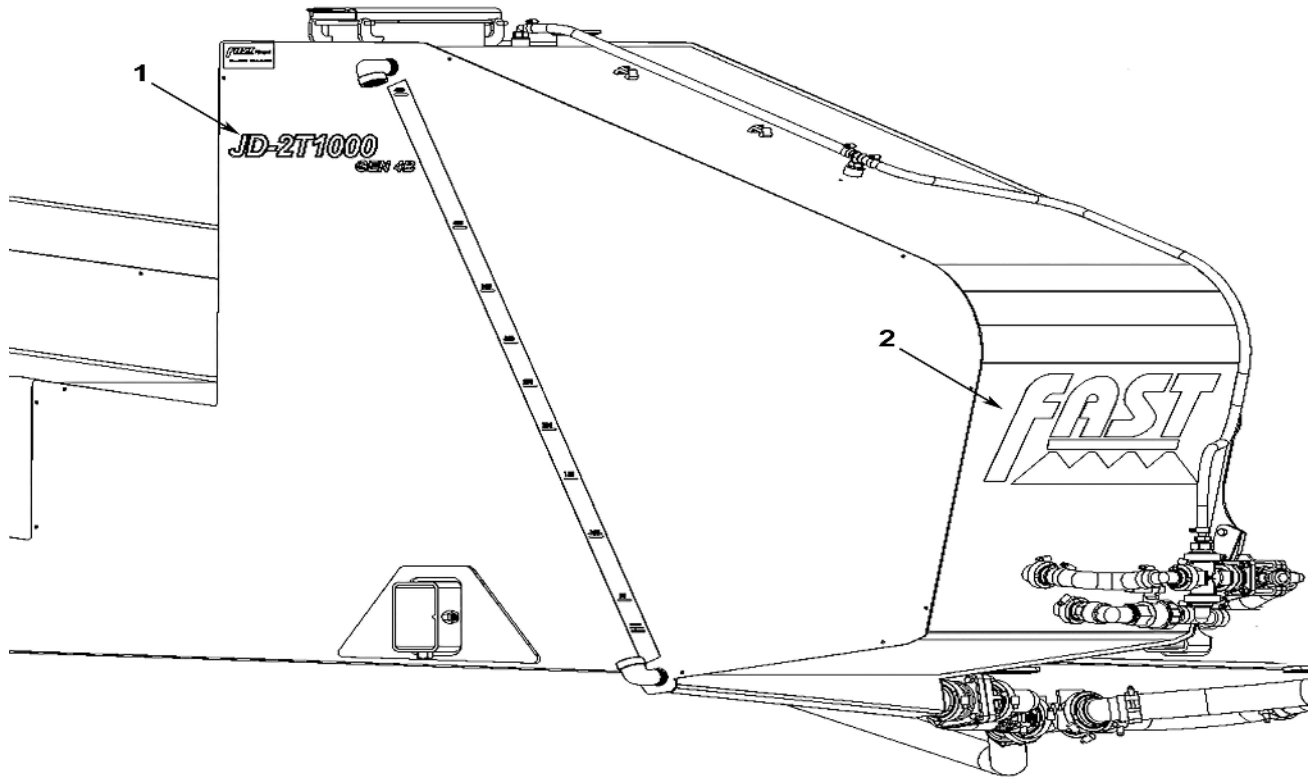



ILLUSTRATED PARTS LIST

Tanks and Hardware With Rinse Out Parts List

ITEM	PART NO.	QTY.	DESCRIPTION
1	800292	2	DECAL, TANK JD-2T1000 GEN 4B
2	800079	2	FAST TANK LOGO

Tanks and Hardware With Rinse Out

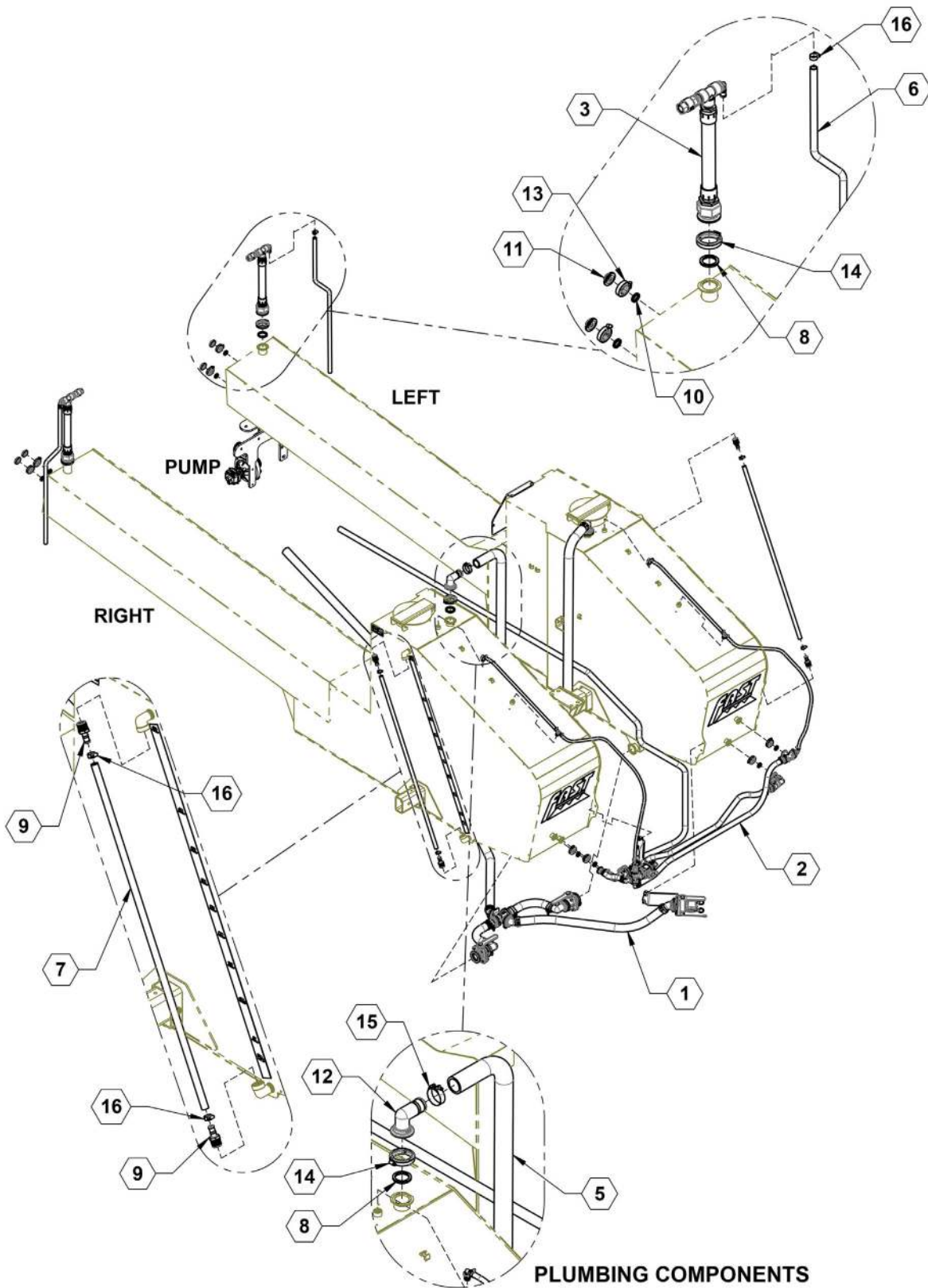



ILLUSTRATED PARTS LIST

Tanks and Hardware With Rinse Out Parts List

ITEM	PART NO.	QTY.	DESCRIPTION
1	99FTTJDRO2QF	1	JD RINSE OUT 2.00 QUICK FILL
2	99FTTJDSRO	1	JD AGITATION / RINSE OUT PLUMBING
3	10216	2	JD RISER ASSY W/ CHECK VALVE
4	19940	1	BRACKET, ADAPTER, WINDSHIELD WASHER
5	510003	2	HOSE, 2.00 FERTILIZER X 72"
6	510006	2	HOSE, .75 CLEAR VINYL X 50"
7	510006	2	HOSE, .75 CLEAR VINYL X 54"
8	530019	4	GASKET, 2.00 EPDM
9	530043	4	FITTING, 1.00 MPT X .75 HB
10	530068	4	GASKET, 1.00 EPDM
11	530070	4	PLUG, MANIFOLD, 1.00
12	530104	2	ELBOW 90, 2.00 FP MANIFOLD X 2.00 HB
13	540000	4	CLAMP, WORM SCREW, 1.00
14	540002	4	CLAMP, FP WORM SCREW, 2.00
15	540007	2	HOSE CLAMP, 2.00 T-BOLT
16	540013	6	HOSE CLAMP, SS .75 #12
17	800021	2	FAST LOCATION DECAL
18	800181	2	FAST TANK LOGO
19	800206	1	RH GALLON DECAL
20	800207	1	LH GALLON DECAL

Riser Assembly With Check Valve

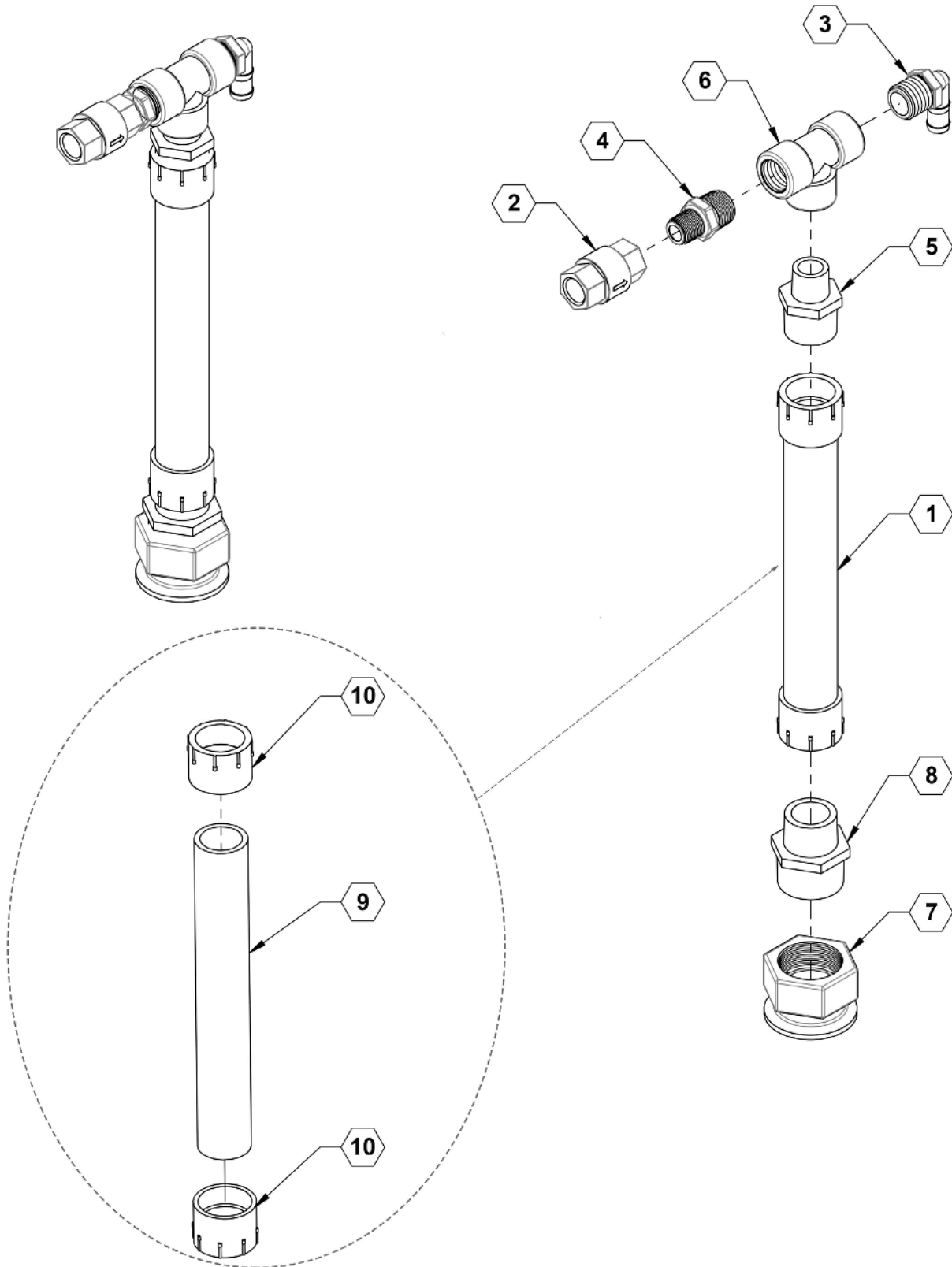



ILLUSTRATED PARTS LIST

Riser Assembly With Check Valve Parts List

ITEM	PART NO.	QTY.	DESCRIPTION
1	10217	1	RISER ASSEMBLY, 13.00 TUBE
2	500014	1	CHECK VALVE, .75 VITON F, POLY
3	530042	1	ELBOW, 90 DEG, 1.00 MPT X .75 HB, POLY
4	530148	1	NIPPLE, REDUCER, 1.00 MPT X .75 MPT, POLY
5	530149	1	NIPPLE, REDUCING, 1.50 MPT X 1.00 MPT, POLY
6	530157	1	TEE, 1.00 PIPE, POLY
7	530243	1	FITTING, MANIFOLD, 2.00 FP X 2.00 FNPT
8	530249	1	NIPPLE, REDUCING, 2.00 x 1.50, POLY
9	10218	1	ABS PLASTIC PIPE, 1.50
10	530251	2	ADAPTER HUB, 1.50 POLY

Plumbing

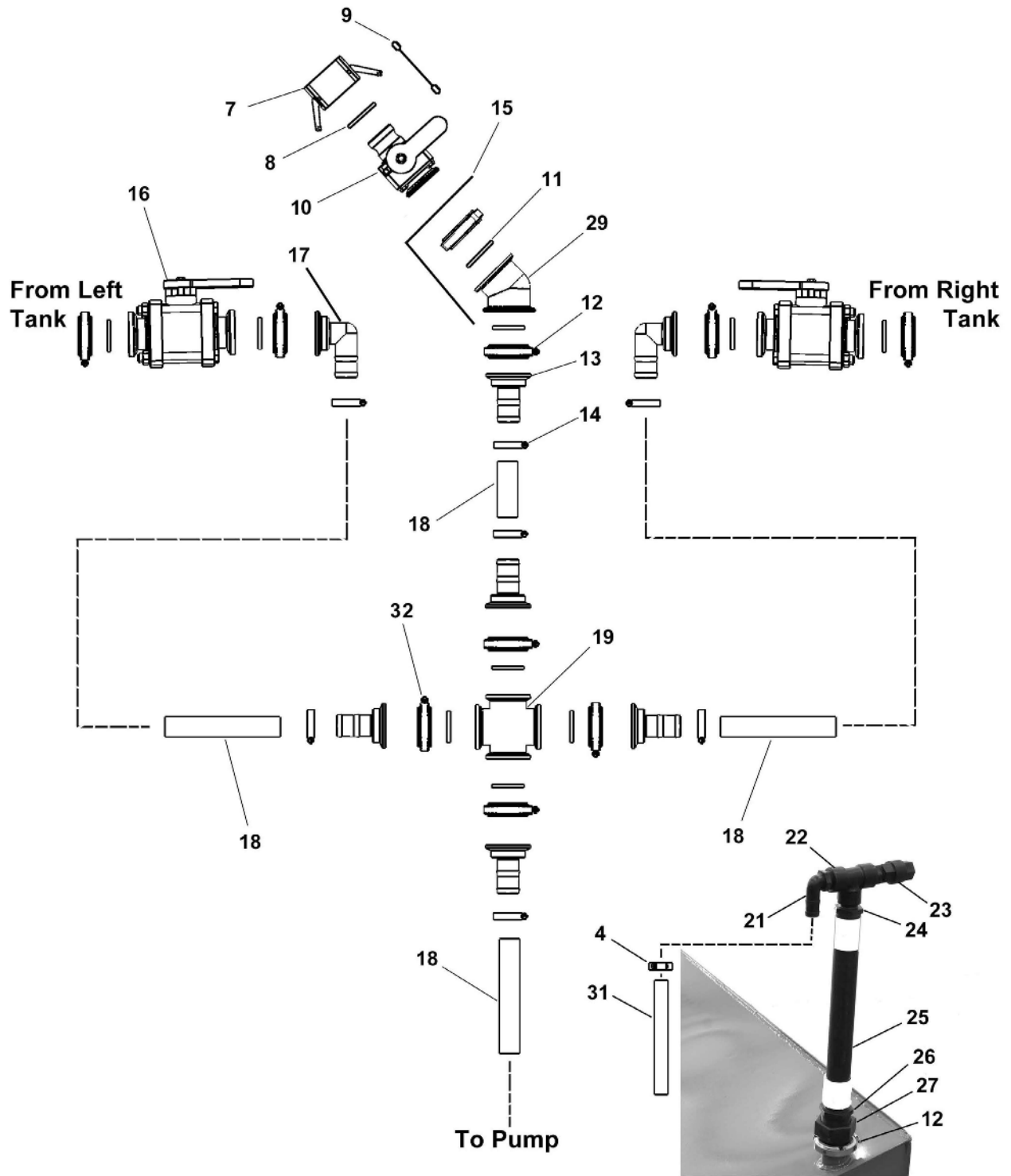



ILLUSTRATED PARTS LIST

Plumbing Parts List

ITEM	PART NO.	QTY.	DESCRIPTION
7	530017	1	Cap, 2"
8	530019	A/R	Gasket (Part of 530017)
9	530179	1	Cable Lanyard
10	530128	1	Manifold Valve 2" Full Port x Male Adapter
11	530019	11	Gasket, 2"
12	540002	11	Clamp, 2"
13	530103	5	Flanged Hose Barb, 2"
14	540007	8	T-Bolt Clamp 2" Hose
15	10206	1	Mount, Quick Fill Valve
16	530328	2	Valve, 2"
17	530104	2	Flanged Hose Barb 90°, 2"
18	510003	A/R	2" Hose, Cut To Fit
19	530107	1	Full Port Flanged Cross, 2"
21	530044	2	1" MPT x 1" Hose Barb 90
22	530157	2	1" Poly Tee
23	500014	2	3/4" Check Valve
24	530149	2	Poly Reducing Nipple
25	10217	2	JD Riser Assembly 13" Tube
26	530249	2	2" x 1-1/2" Reducing Nipple
27	530243	2	2" FP Manifold x 2" FPT
29	530105	2	2" x 2" 45° Full Port Coupling
31	510006	2	Hose Vinyl 1" x 48"
32	540002	8	Clamp, Worm Screw, 2"

Side Tanks

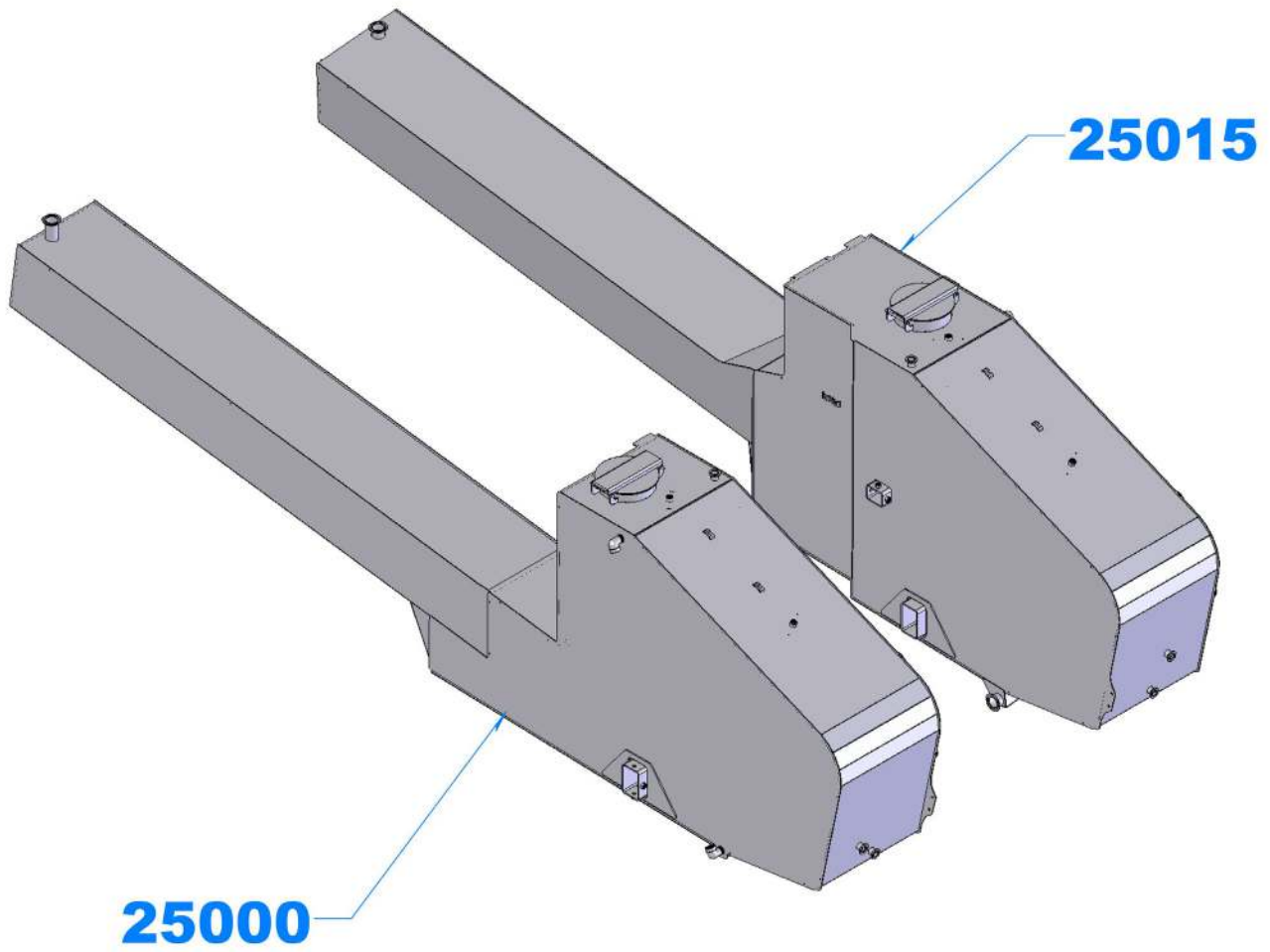



ILLUSTRATED PARTS LIST

Side Tanks Parts List

ITEM	PART NO.	QTY.	DESCRIPTION
0	25000	1	JD RINSE OUT TANK, RH, SS
0	25015	1	JD RINSE OUT TANK, LH, SS

2" Quick Fill & SRO Plumbing

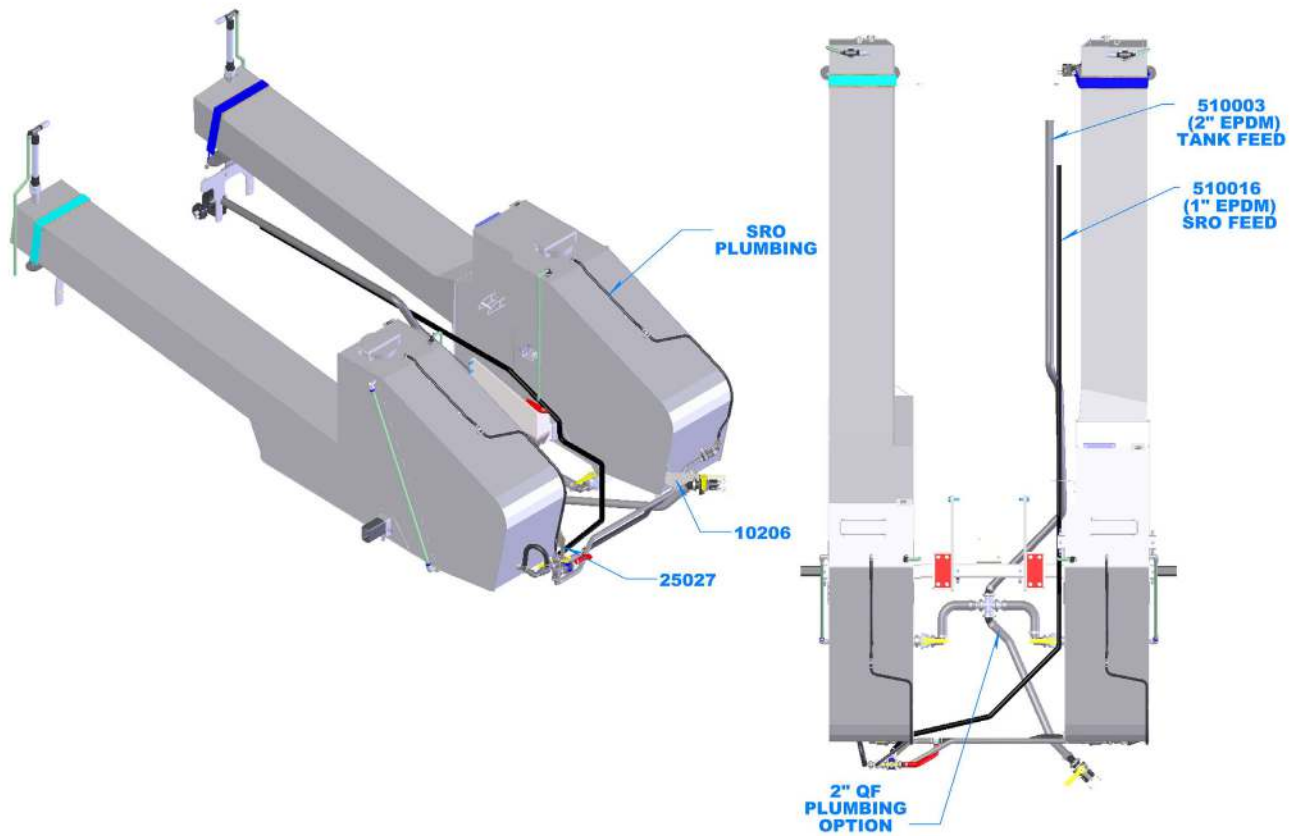

JD 2" Quick Fill & SRO PLUMBING



ILLUSTRATED PARTS LIST

2" Quick Fill & SRO Plumbing Parts List

ITEM	PART NO.	QTY.	DESCRIPTION
0	10206	1	2" QUICK FILL MOUNT
0	25027	1	RO (RINSE OUT) SIDE LOAD VALVE MOUNT
0	510003	14	HOSE, 2" FERTILIZER
0	510016	30	HOSE, VINYL, CLEAR 3/4"

Hanger Hardware

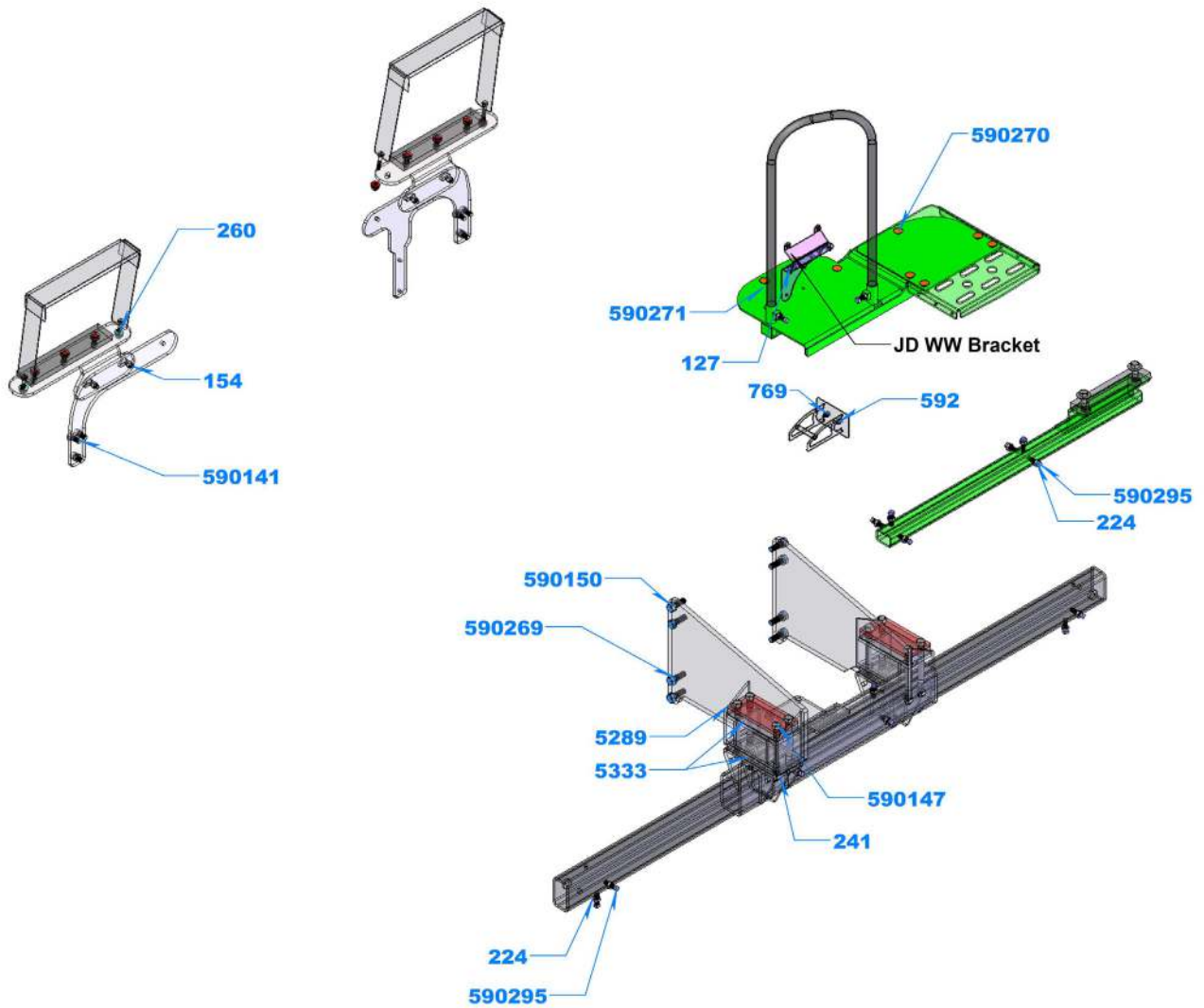

FASTENERS ARE IN THE **99FTHRDWREFT4B** HARDWARE KIT



ILLUSTRATED PARTS LIST

Hanger Hardware Parts List

ITEM	PART NO.	QTY.	DESCRIPTION
0	127	4	BOLT, HH, 3/8 X 3/4 NC GR5 ZP
0	154	10	BOLT, HH, 1/2 X 2 NC GR5 ZP
0	224	12	NUT, HH, JAM, 5/8 NC ZP
0	241	8	NUT, HH, CENTERLOCK, 3/4 NC ZP
0	260	26	WASHER, FLAT, 1/2 ZP
0	592	4	BOLT, CARRIAGE, 3/8 X 1 ZP
0	769	4	NUT, WHIZLOCK, FLANGE, 3/8-16
0	5289	2	PLATE, 1/2 X 4-1/2, WITH HOLES
0	5333	4	RUBBER MOUNT, 1X4X9.5
0	590141	6	BOLT, HH, 16X40MM GR8.8 ZP
0	590147	8	BOLT, HH, 3/4 X 9 NC GR5 ZP
0	590150	8	BOLT, HH, 20 X 60MM GR10.9 ZP
0	590269	8	LOCKWASHER, 20MM
0	590270	9	CARRIAGE BOLT, 16 X 40 MM ZP
0	590271	9	HEX NUT 16 X 2.0 MM ZP
0	590295	16	5/8-11 X 2 SQ HEAD SET SCREW

Hanger Parts

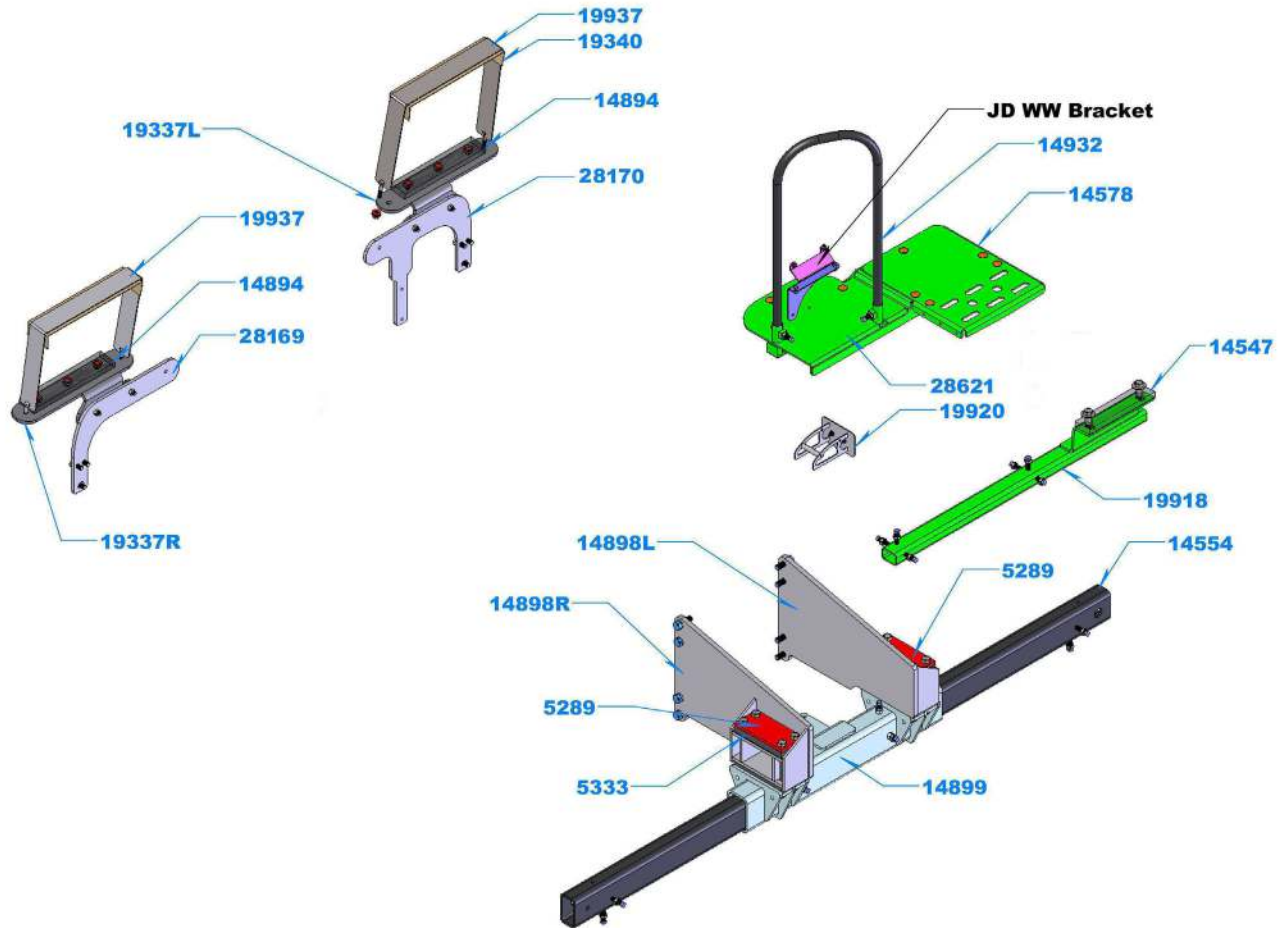



ILLUSTRATED PARTS LIST

Hanger Parts List

ITEM	PART NO.	QTY.	DESCRIPTION
0	5289	2	PLATE, 1/2 X 4-1/2" WITH HOLES
0	5333	4	RUBBER MOUNT, 1X4-1/2 X 9-1/2"
0	14547	1	RUBBER STEP PAD 3G TANK
0	14554	1	TUBE, TANK CARRIER
0	14578	1	JD 3G TOP STEP
0	14894	2	4G RUBBER TANK PAD
0	14899	1	JD 4G TANK MOUNT RECIEVER
0	14932	1	SAFETY RAIL
0	28621	1	PLATFORM EXTENSION JD
0	28169	1	BRACKET, JD 4GUW RH TAIL
0	28170	1	BRACKET, JD 4GUW LH TAIL
0	19339	1	SS TAIL STRAP
0	19340	2	TANK PROTECTOR 4" WEBBING
0	19918	1	JD FT4B STEP TUBE
0	19920	1	DEF FILLER MOUNT
0	19938	1	RH TAIL STRAP
0	14898L	1	LH TANK RECIEVER MOUNT JD 4G
0	14898R	1	RH TANK RECIEVER MOUNT JD 4G
0	19337L	1	LH TAIL STRAP BRACKET
0	19337R	1	RH TAIL STRAP WELDMENT

Agitation / Rinse Out Plumbing

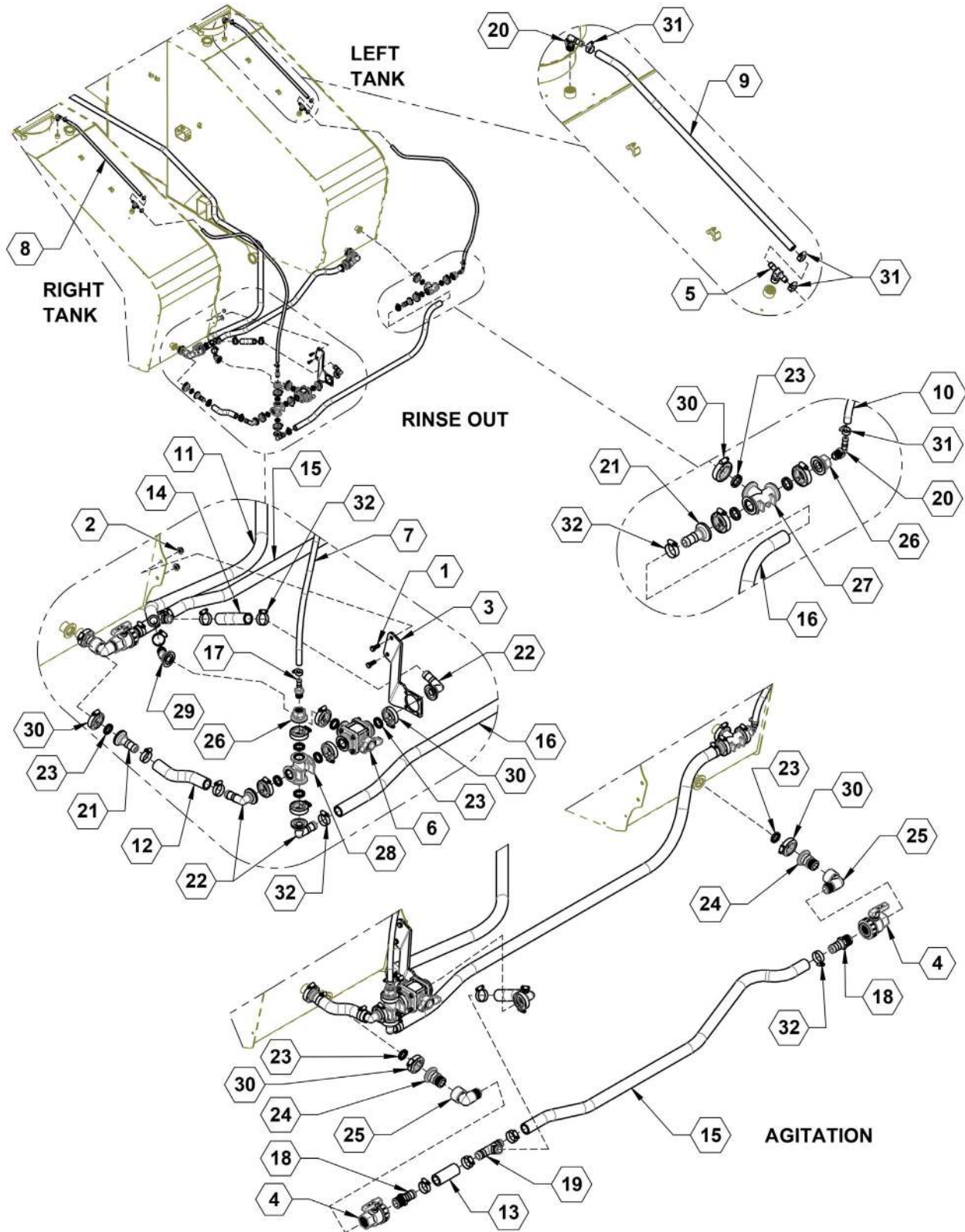



ILLUSTRATED PARTS LIST

Agitation / Rinse Out Plumbing Parts List

ITEM	PART NO.	QTY.	DESCRIPTION
1	128	2	BOLT, HH 3/8-16 X 1 GR5 ZINC
2	769	2	NUT, 3/8-16 WHIZLOCK, ZP
3	25027	1	BRACKET, VALVE MOUNT
4	500009	2	VALVE, 1.00 FULL PORT SINGLE UNION
5	500065	2	TEE, .50 MPT X .50 HB
6	500075	1	VALVE, 1.00 MANIFOLD, 3-WAY BOTTOM LOAD
7	510012	1	HOSE, .50 EPDM X 60"
8	510012	1	HOSE, .50 EPDM X 32"
9	510012	1	HOSE, .50 EPDM X 32"
10	510012	1	HOSE, .50 EPDM X 54"
11	510016	1	HOSE, 1.00 EPDM X 206"
12	510016	1	HOSE, 1.00 EPDM X 8"
13	510016	1	HOSE, 1.00 EPDM X 3.5"
14	510016	1	HOSE, 1.00 EPDM X 6"
15	510016	1	HOSE, 1.00 EPDM X 52"
16	510016	1	HOSE, 1.00 EPDM X 68"
17	530035	1	1/2 MPT 1/2" BRB
18	530041	2	FITTING, 1.00 MNPT X 1.00 HB, POLY
19	530056	1	FITTING, TEE, 1.00 HB, POLY
20	530059	3	ELBOW 90, .50 MPT X .50 HB, POLY
21	530426	1	ELBOW 45, 1.00 FLANGE X 1.00 HB
21	530066	2	FITTING, 1.00 MANIFOLD X 1.00 HB
22	530067	3	FITTING, ELBOW, 1" MANIFOLD X 1" HB 90°
23	530068	12	GASKET, 1.00 EPDM
24	530069	2	FITTING, 1.00 MANIFOLD X 1.00 MPT
25	530152	2	ELBOW 90, 1.00 STREET
26	530265	2	FITTING, 1.00 MANIFOLD X .50 FPT
27	530298	1	MANIFOLD TEE, 1"
28	530413	1	CROSS FITTING, 1.00
29	530426	1	ELBOW 45, 1.00 FLANGE X 1.00 HB
30	540000	12	CLAMP, WORM SCREW, 1.00
31	540012	8	HOSE CLAMP, SS 1/2" #12
32	540014	11	HOSE CLAMP, SS 1.00 #16

2" Quick Fill Option

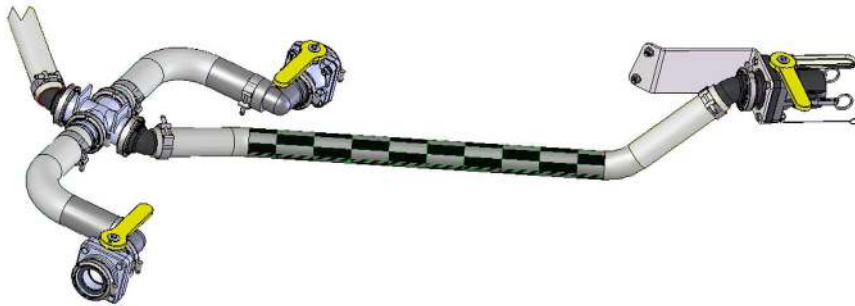
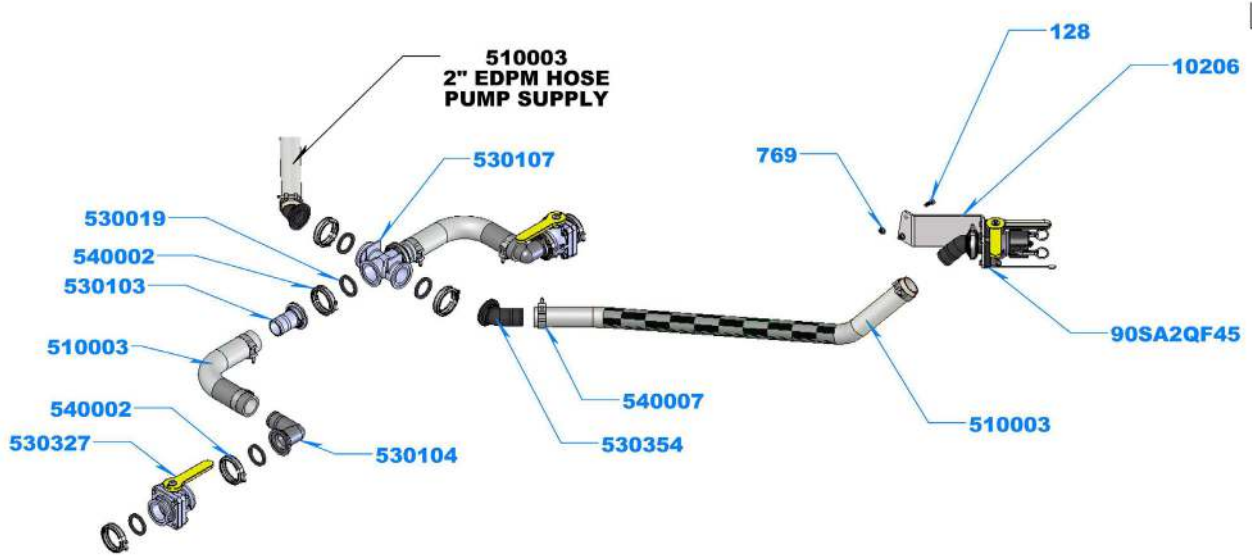

JD 2" Quick Fill Option



ILLUSTRATED PARTS LIST

2" Quick Fill Option Parts List

ITEM	PART NO.	QTY.	DESCRIPTION
0	128	2	BOLT, HH 3/8-16 X 1
0	769	2	3/8-16 Whizz Nut
0	10206	1	2" QUICK FILL MOUNT
0	510003	20FT	2" EDPM HOSE
0	530019	8	GASKET, 2" EPDM
0	530103	2	2" FP FLANGE X 2" HOSE BARB
0	530104	2	2" X 2 " HOSE BARB, 90°
0	530107	1	2" Full Port Flanged Cross
0	530327	2	2" Manifold Stubby Valve
0	530354	2	2" Flanged Hose Barb 45°
0	540002	8	CLAMP, WORM SCREW 2"
0	540007	7	HOSE CLAMP, 2" T-BOLT
0	99SA2QF45	1	2" QUICK FILL, 45°

3" Quick Fill Option

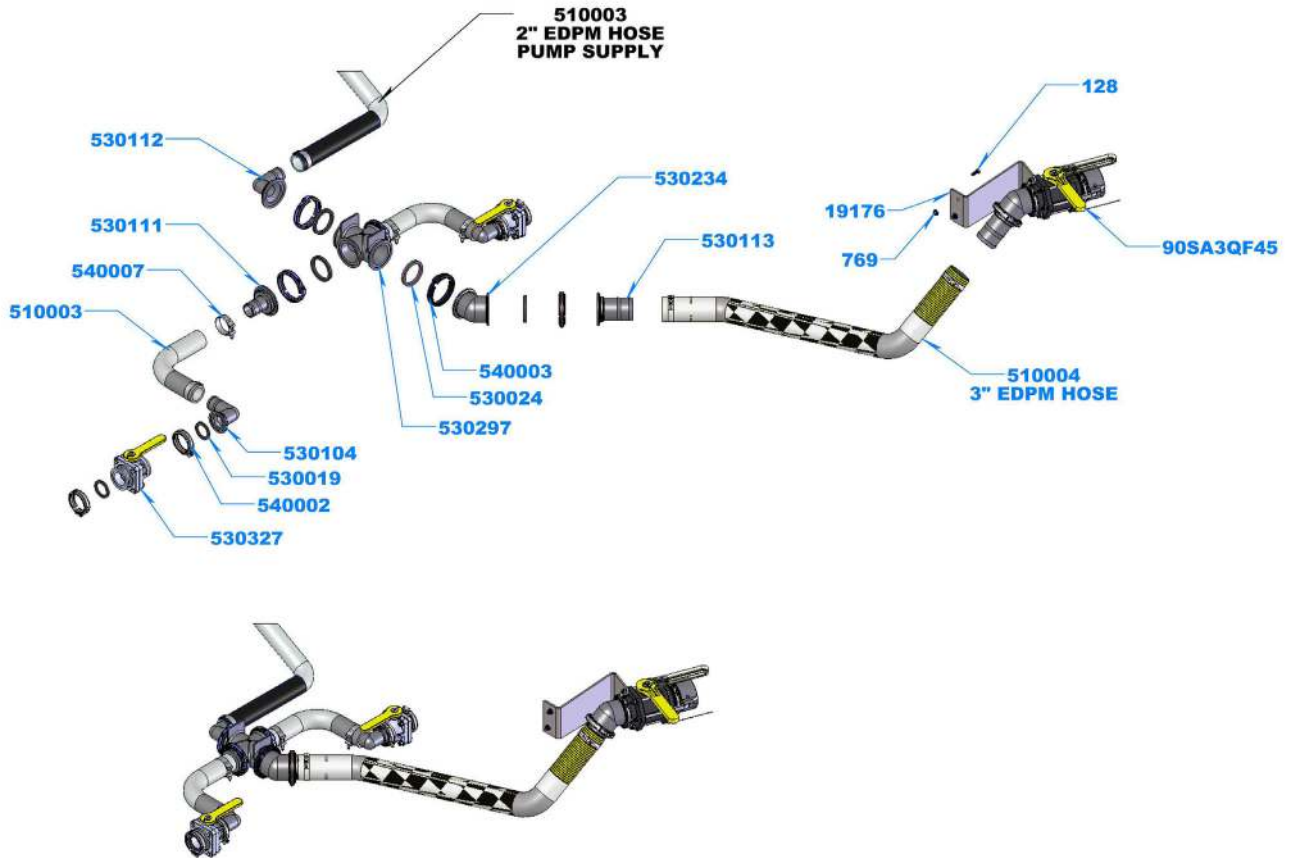

JD 3" Quick Fill Option



ILLUSTRATED PARTS LIST

3" Quick Fill Option Parts List

ITEM	PART NO.	QTY.	DESCRIPTION
0	128	2	BOLT, HH 3/8-16 X 1
0	769	2	3/8-16 Whizz Nut
0	510003	15FT	2" FERTILIZER HOSE
0	510004	5FT	HOSE, 3" FERTILIZER
0	530019	4	GASKET, 2" EPDM
0	530024	5	GASKET, 3" EPDM
0	530104	2	2" X 2 " HOSE BARB90°
0	530111	2	3" MAN X 2" HOSE BARB
0	530112	1	3' MANIFOLD X 2" HOSE BARB 90
0	530113	1	Flanged 3 Inch Hose Barb
0	530234	1	3" COUPLER, 45°
0	530297	1	Flanged Cross 3 Inch
0	530327	2	2" Manifold Stubby Valve
0	540002	4	CLAMP, WORM SCREW 2"
0	540003	5	CLAMP, 3" WORM SCREW
0	540007	5	HOSE CLAMP, 2" T-BOLT
0	540009	2	CLAMP, 3" T BOLT
0	90SA3QF45	1	3" QUICK FILL VALVE @ 45°

2" Quick Fill Valve, 45D

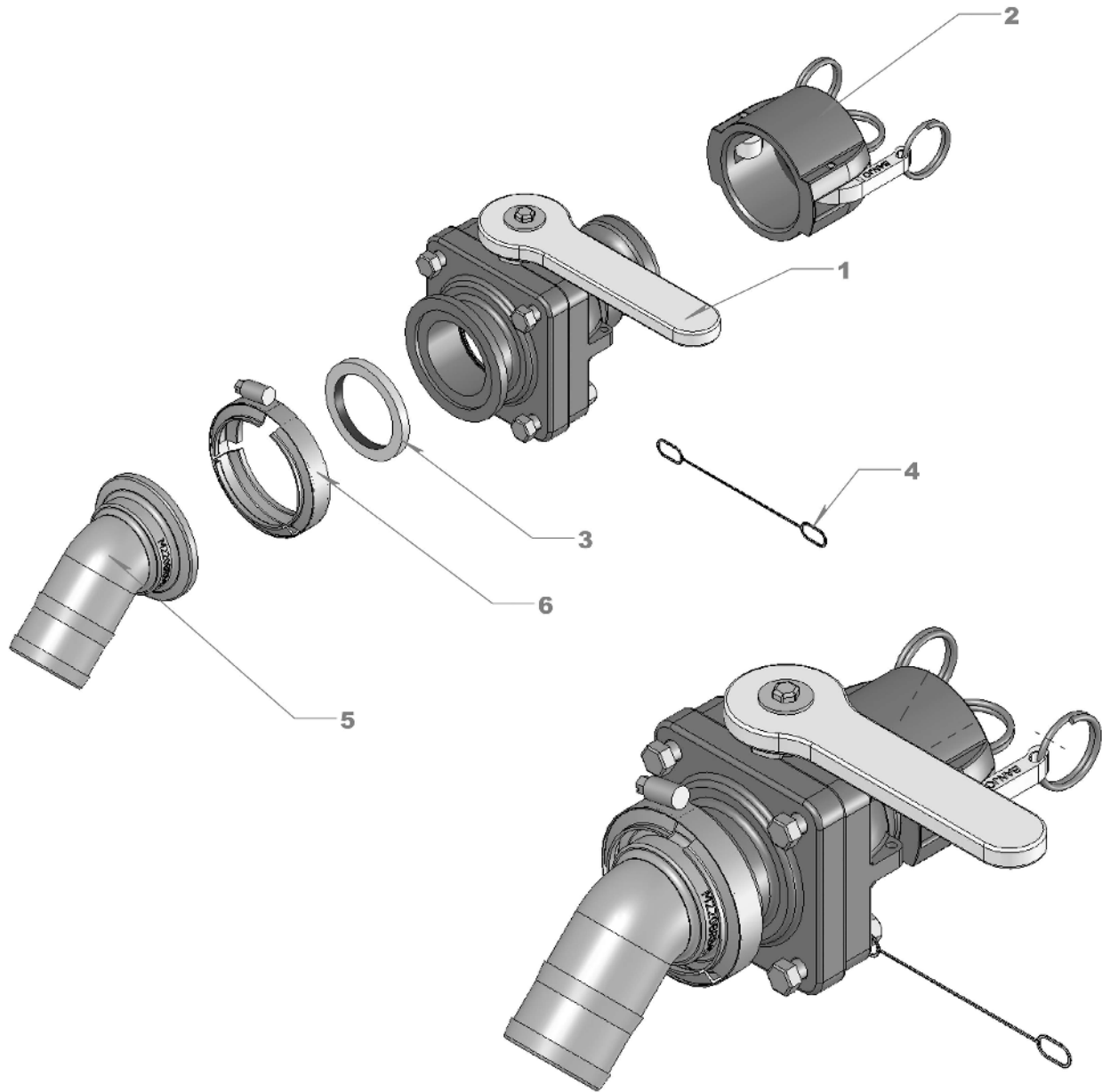



ILLUSTRATED PARTS LIST

2" Quick Fill Valve, 45D Parts List

ITEM	PART NO.	QTY.	DESCRIPTION
1	500035	1	Stubby Valve FP Flange 2" Male Adapter
2	530017	1	BANJO 2" QUICK FILL CAP
3	530019	1	GASKET, 2" EPDM
4	530179	1	CABLE LANYARD
5	530354	1	2" Flanged Hose Barb 45°
6	540002	1	CLAMP, WORM SCREW 2"

3" Quick Fill Valve, 45D

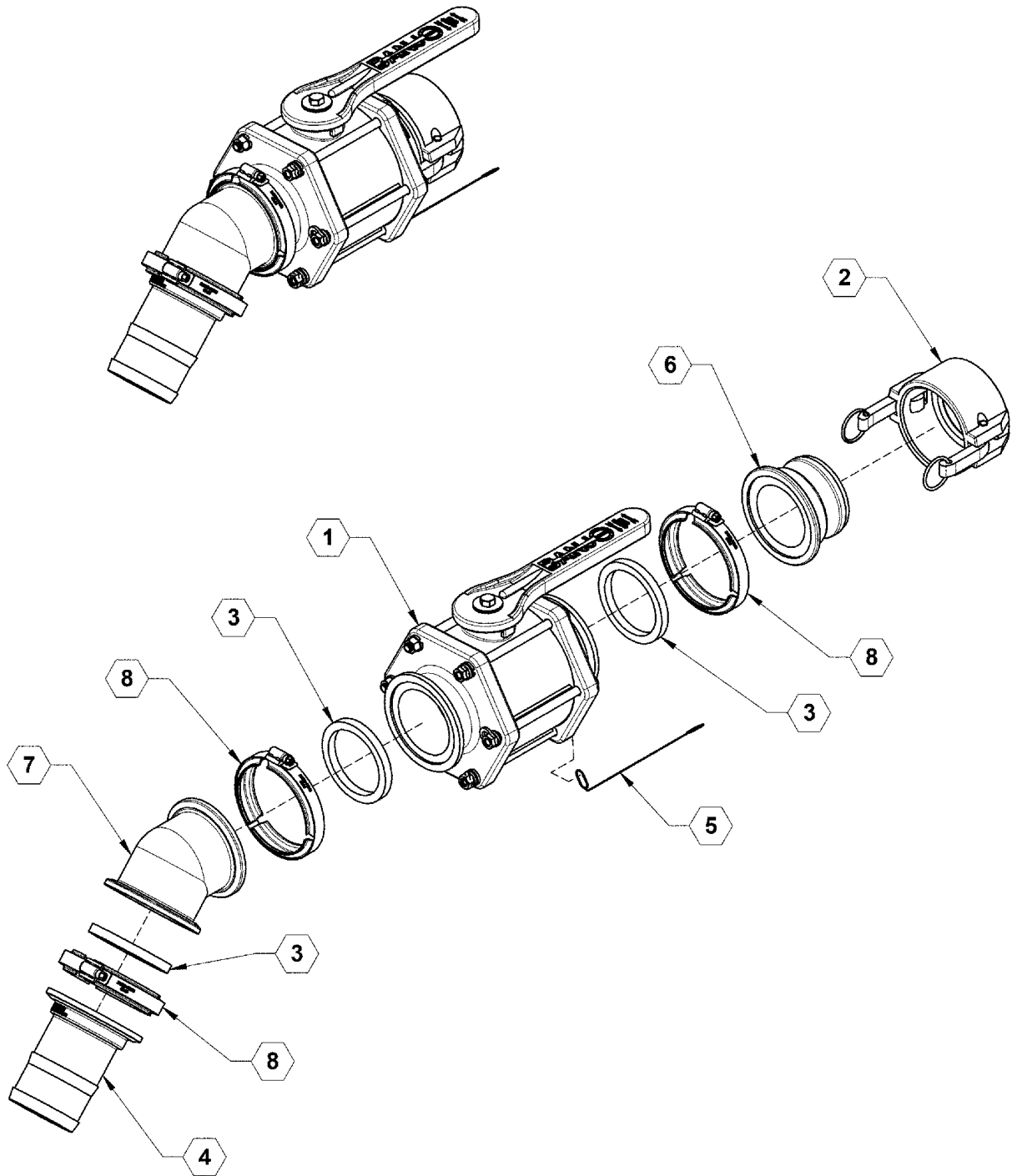



ILLUSTRATED PARTS LIST

3" Quick Fill Valve, 45D Parts List

ITEM	PART NO.	QTY.	DESCRIPTION
1	500042	1	VALVE, 3" FLANGED MANIFOLD
2	530023	1	CAP, 3"
3	530024	3	GASKET, 3" EPDM
4	530113	1	Flanged 3 Inch Hose Barb
5	530179	1	CABLE LANYARD
6	530233	1	3" MANIFOLD X 3" MALE ADAPTER
7	530234	1	3" MANIFOLD COUPLER, 45
8	540003	3	CLAMP, 3" WORM SCREW

Def Tank Heat Shield Kit

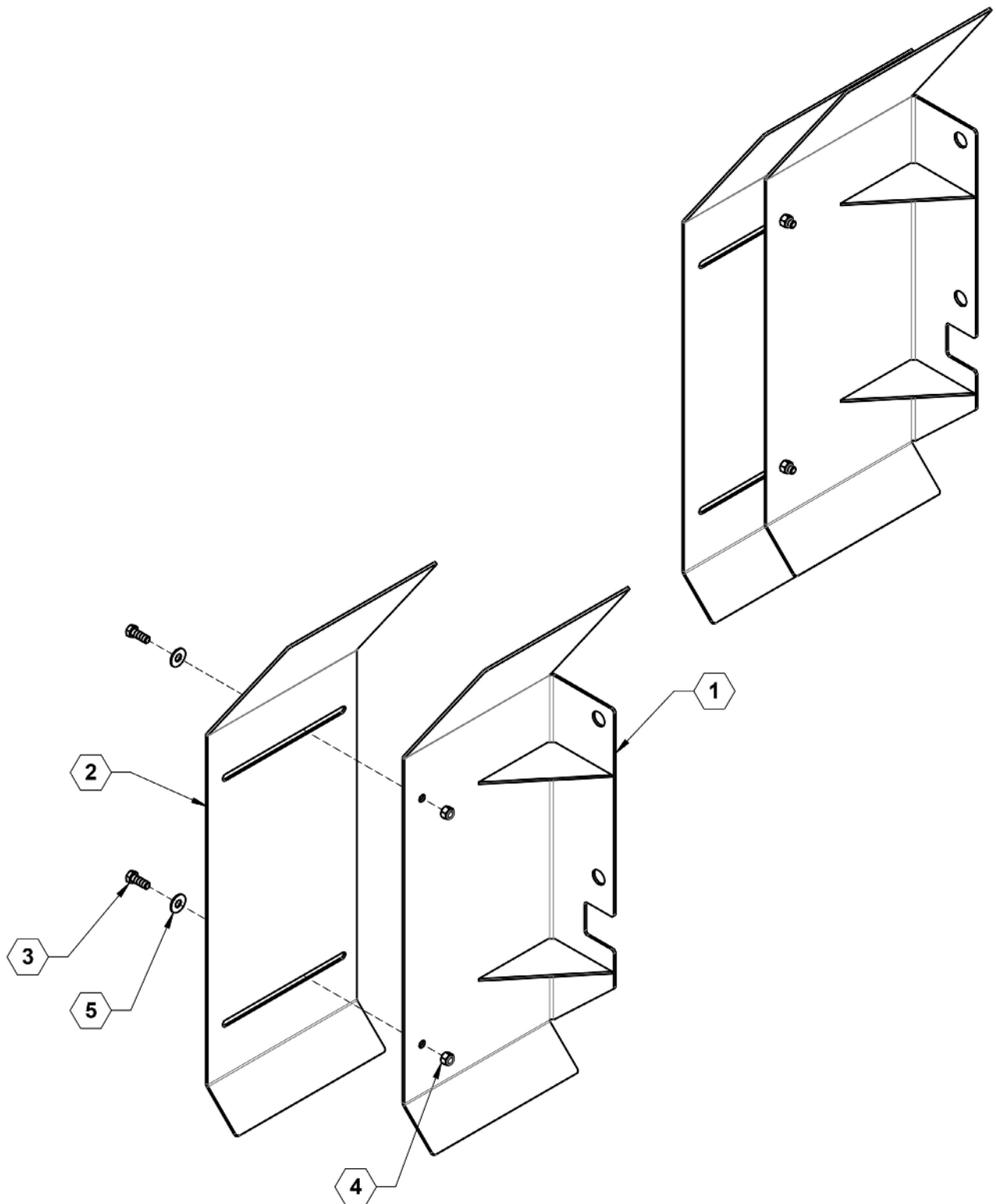



ILLUSTRATED PARTS LIST

Def Tank Heat Shield Kit Parts List

ITEM	PART NO.	QTY.	DESCRIPTION
1	21446	1	DEF TANK HEAT SHIELD
2	21448	1	SLIDING HEAT SHIELD
3	596128M	2	BOLT, HH G5 3/8 X 1 MAGNI
4	596229M	2	NUT HEX NYLOCK 3/8 MAGNI
5	596258M	2	WASHER 3/8 USS MAGNI



Assembly Checklist

Assembly Checklist

Complete this check after assembly.

	Task
	All hardware is installed and torqued to proper rating.
	All hydraulic fittings are attached tightly.
	All electric harnesses are connected.
	All plumbing and hose lines are connected tightly
	Hydraulic and electrical lines have been zip tied to prevent damage.
	All grease zerks are installed.
	All decals are in place.



Assembly Checklist

SPECIFICATIONS

Hydraulic Fitting Torque

Tightening flare type tube fittings*

1. Check flare and flare seat for defects that might cause leakage.
2. Align tube with fitting before tightening.
3. Lubricate connection and hand tighten swivel nut until snug.
4. To prevent twisting tubes or hoses, use two wrenches. Place one wrench on connector body and with second wrench tighten swivel nut to torque shown.

*Torque values shown are based on lubricated connections.

Tube Size OD	Nut Size Across Flats	Torque Value*		Recommended Turns to Tighten (After Finger Tightening)	
		(N-m)	(lb-ft)	(Flats)	(Turns)
(in.)	(in.)				
3/16	7/16	8	6	1	1/6
1/4	9/16	12	9	1	1/6
5/16	5/8	16	12	1	1/6
3/8	11/16	24	18	1	1/6
1/2	7/8	46	34	1	1/6
5/8	1	62	46	1	1/6
3/4	1-1/4	102	75	3/4	1/8
7/8	1-3/8	122	90	3/4	1/8

Metric Torque-Tension Values								
B o l t S i z e	C l a s s 4 . 8		C l a s s 8 . 8		C l a s s 1 0 . 9		C l a s s 1 2 . 9	
	Dry ft-lbs(N-m)	Lubricated ft-lbs(N-m)	Dry ft-lbs(N-m)	Lubricated ft-lbs(N-m)	Dry ft-lbs(N-m)	Lubricated ft-lbs(N-m)	Dry ft-lbs(N-m)	Lubricated ft-lbs(N-m)
M6	3.5 (4.7)	4.5 (6)	6.5 (8.9)	8.5 (11.3)	9.5 (13)	12 (16.5)	11.5 (15.5)	14.5 (19.5)
M8	8.5 (11.5)	10.5 (14.5)	16 (22)	20 (27.5)	23.5 (32)	29.5 (40)	27.5 (37)	35 (47)
M10	17 (23)	21 (29)	32 (43)	40 (55)	46 (63)	59 (80)	55 (75)	70 (95)
M12	29.5 (40)	37 (50)	55 (75)	70 (95)	80 (110)	105 (140)	95 (130)	120 (165)
M14	46 (63)	59 (80)	88 (120)	110 (150)	130 (175)	165 (220)	150 (205)	190 (260)
M16	74 (100)	92 (125)	140 (190)	175 (240)	200 (275)	255 (350)	235 (320)	300 (400)
M18	100 (135)	125 (170)	195 (265)	245 (330)	275 (375)	350 (475)	325 (440)	410 (560)
M20	140 (190)	180 (245)	275 (375)	350 (475)	390 (530)	500 (675)	460 (625)	580 (790)
M22	195 (265)	245 (330)	375 (510)	480 (650)	535 (725)	680 (920)	625 (850)	800 (1080)
M24	245 (330)	315 (425)	480 (650)	600 (820)	680 (920)	850 (1150)	800 (1080)	1000 (1350)



Assembly Checklist

SAE Torque-Tension Values						
Bolt Size	Grade 2		Grade 5		Grade 8	
	Dry lb-fts (N-m)	Lubricated lb-fts (N-m)	Dry lb-fts (N-m)	Lubricated lb-fts (N-m)	Dry lb-fts (N-m)	Lubricated lb-fts (N-m)
1/4-28	6 (9)	5 (6)	10 (13)	7 (10)	14 (19)	10 (14)
1/4-20	6 (8)	4 (6)	8 (11)	6 (9)	12 (16)	9 (12)
5/16-24	13 (17)	9 (13)	19 (23)	14 (20)	27 (37)	20 (28)
5/16-18	11 (15)	8 (11)	17 (24)	12 (18)	25 (33)	18 (25)
3/8-24	23 (31)	17 (23)	35 (48)	26 (36)	49 (59)	37 (44)
3/8-16	20 (27)	15 (20)	31 (42)	23 (31)	44 (59)	32 (44)
7/16-20	36 (48)	27 (36)	55 (75)	41 (56)	78 (106)	58 (79)
7/16-14	32 (43)	24 (33)	49 (67)	37 (50)	70 (95)	52 (71)
1/2-20	55 (75)	41 (56)	85 (115)	64 (86)	120 (163)	90 (122)
1/2-13	49 (66)	37 (50)	75 (102)	57 (77)	106 (144)	80 (108)
9/16-18	78 (106)	59 (80)	121 (164)	91 (123)	171 (232)	128 (174)
9/16-12	70 (95)	53 (72)	109 (148)	82 (111)	154 (209)	115 (156)
5/8-18	110 (149)	82 (111)	170 (231)	127 (172)	240 (326)	180 (244)
5/8-11	97 (132)	73 (99)	150 (204)	113 (153)	212 (288)	159 (216)
3/4-16	192 (261)	144 (195)	297 (403)	223 (303)	420 (570)	315 (427)
3/4-10	172 (233)	129 (175)	269 (365)	201 (273)	376 (510)	282 (383)
1-12	--	--	704 (955)	528 (716)	995 (1350)	746 (1012)
1-8	--	--	644 (874)	483 (655)	909 (1233)	681 (924)



NOTES



FAST GLOBAL SOLUTIONS

4130 Commerce Boulevard

Windom, MN 56101

1-800-772-9279 Toll Free

1-507-427-3861 Voice

1-507-427-3030 Fax

www.fastsprayers.com