

FAST™

AG SOLUTIONS



RH15 / RH18 ROTARY HOE PARTS MANUAL - 2019





FAST GLOBAL
SOLUTIONS



ILLUSTRATED PARTS LIST

Limited Warranty

FAST AG Solutions warrants to the buyer that the new machinery is free from defects in material and workmanship.

This warranty is only effective as to any new machinery which has not been altered, changed, repaired or treated since its delivery to the buyer, other than by FAST AG Solutions or its authorized dealers or employees, and does not apply to accessories, attachments, tools or parts, sold or operated with the new machinery, if they have not been manufactured by FAST AG Solutions.

FAST AG Solutions shall only be liable for defects in the materials or workmanship attributable to faulty material or bad workmanship that can be proved by the buyer, and specifically excludes liability for repairs arising as a result of normal wear and tear of the new machinery or in any other manner whatsoever, and without limiting the generality of the foregoing, excludes application or installation of parts not completed in accordance with this operator's manual, specifications, or printed instructions.

Written notice shall be given by registered mail, to the Manufacturer within seven (7) days after the defect shall have become apparent or the repairs shall have become necessary, addressed as follows:

FAST AG Solutions
4130 Commerce Boulevard
Windom, MN 56101

This warranty shall expire one (1) year after the date of delivery of the new machinery.

If these conditions are fulfilled, FAST AG Solutions shall at its own cost and at its own option either repair or replace any defective parts provided that the buyer shall be responsible for all expenses incurred as a result of repairs, labor, parts, transportation or any other work, unless FAST AG Solutions has authorized such expenses in advance.

The warranty shall not extend to any repairs, changes, alterations, or replacements made to the new equipment other than by FAST AG Solutions or its authorized dealers or employees.

This warranty extends only to the original owner of the new equipment.

Rubber parts (including tires, hoses, grommets) are not warranted.

This warranty is limited to the terms stated herein and is in lieu of any other warranties whether express or implied, and without limiting the generality of the foregoing, excluded all warranties, express or implied or conditions whether statutory or otherwise as to quality and fitness for any purpose of the new equipment. the Manufacturer disclaims all liability for incidental or consequential damages.

This Rotary Hoe is subject to design changes and FAST AG Solutions shall not be required to retrofit or exchange items on previously sold units except at its own option.

Warranty void if not registered.



ILLUSTRATED PARTS LIST

FAST

RH15 / RH18 Rotary Hoe

Warranty Registration Form & Inspection Report

Warranty Registration

This form must be filled out by the dealer and signed by both the dealer and the customer at the time of delivery.

Customer Name				
Address				
City		State		Zip
Phone				
Dealer Name				
Address				
City		State		Zip
Model Number				
Serial Number				
Delivery Date				

DEALER INSPECTION REPORT

- All Fasteners Tight
- Wheel Bolts Torqued
- Hydraulic Hoses and Fittings Free and Tight
- Fertilizer Hoses and Fittings Free and Tight
- Wheel Drive Turns Freely
- Lubricate Machine
- Check Tire Pressure
- Frame and Wings Level
- Monitors and Controllers Function
- Wiring Harness Connected

SAFETY

- Safety Chain Installed
- All Guards Installed
- All Safety Signs Installed
- Reflectors, SMV and Lights Clean
- Review Operating and Safety Instructions

I have thoroughly instructed the buyer on the above described equipment which review included the Operator's Manual content, equipment care, adjustments, safe operation and applicable warranty policy.

Date _____

Dealer's Rep. Signature _____

The above equipment and Operator's Manual have been received by me and I have been thoroughly instructed as to care, adjustments, safe operation and applicable warranty policy.

Date _____

Owner's Signature _____

- White - FAST
- Yellow - Dealer
- Pink - Customer



ILLUSTRATED PARTS LIST

FAST RH15 / RH18 Rotary Hoe

ROTARY HOE SERIAL NUMBER _____

DATE PURCHASED _____ / _____ / _____

WIDTH _____



ILLUSTRATED PARTS LIST





ILLUSTRATED PARTS LIST

General Information

All rights, especially copying and distribution rights are reserved. No part of this publication may be reproduced in any form or by any means, electronic or mechanical, including photocopying, without express written permission from FAST AG Solutions.

Parts information in this manual represents components installed when product was manufactured based upon the best available information. Modifications made subsequent to initial delivery are not included. Always verify the parts and color required when ordering parts.

If you have any questions, please contact your FAST AG Solutions Parts and Service Department.

Explanation of Parts Lists

The parts lists are broken down sub assemblies and listed in 4 columns:

- ITEM - These numbers are found on the illustration associated with the parts list.
 - NS- This item is NOT SHOWN, included for reference.
- QTY. - This is the quantity of parts needed in an assembly.
 - AR- The quantity of this item is AS REQUIRED for the location.
- PART NO.- These are the part numbers associated to the ITEM.
- DESCRIPTION - This is the description of the part.



ILLUSTRATED PARTS LIST

Table of Contents

Section	Page
Table of Contents	6
Base Rotary Hoe Assembly	8
Base Rotary Hoe Assembly	10
Base Rotary Hoe Assembly	12
Base Rotary Hoe Assembly	14
Bare Base Toolbar Assembly	16
Base Toolbar Assembly	18
Base Toolbar Assembly	20
LH Wing Wheel Assembly	22
RH Wing Wheel Assembly	24
15 Meter Toolbar	26
18 Meter Toolbar	28
Bump Adjust Assembly	30
Row Depth Adjust Assembly	32
Slide Pivot Assembly	34
Hub and Spindle Assembly (N709) 730106	36
Hub and Spindle Assembly (N45-8) 730008	38
Rotary Hoe Wheel Axle Assembly	40
Hydraulic Assembly	42
Center Cylinder Hoses	44
Field Latch Hoses	46
Hydraulic Fitting Locations	48
Wing Fold Hoses	50
Hydraulic Diagram	52
Decals, 15 & 18 Meter Toolbar, FAST	54



ILLUSTRATED PARTS LIST



Base Rotary Hoe Assembly

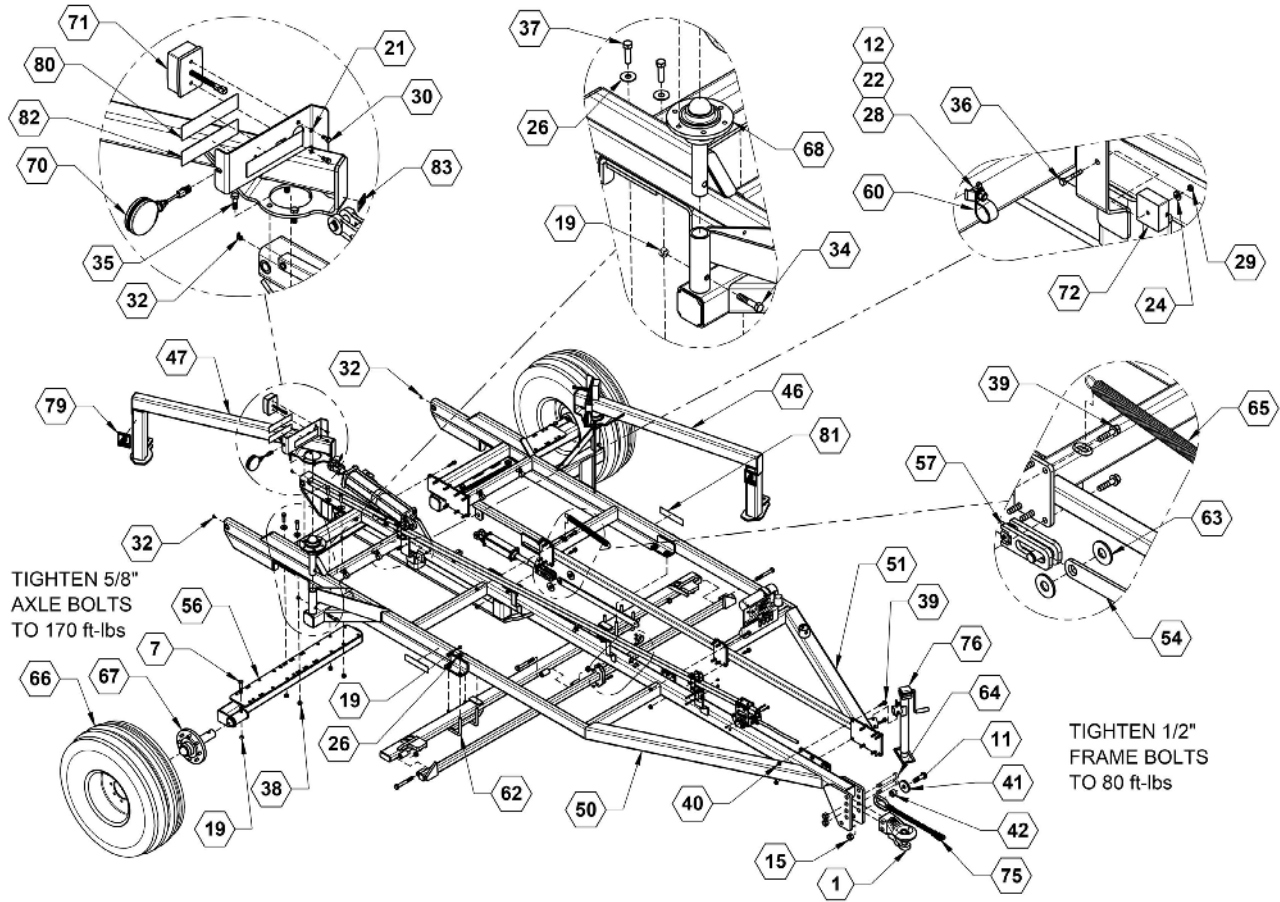



ILLUSTRATED PARTS LIST

Base Rotary Hoe Assembly Parts List

ITEM	PART NO.	QTY.	DESCRIPTION
1	90SAHITCHLG	1	HITCH, LARGE CAT 4
7	173	2	BOLT, HH 5/8 X 3-1/2 NC GR5 ZINC
11	201	1	BOLT, HH 1-8 X 3 1/2 GR5 ZINC
12	213	11	NUT, HEX 3/8-16 ZINC
15	234	3	NUT, HEX NYLOCK 1-8 ZINC
19	240	12	NUT, CENTERLOCK, 5/8-11, ZINC
21	248	4	WASHER, LOCK, 1/4 ZINC
22	250	11	LOCKWASHER, 3/8 ZINC
24	256	5	WASHER, FLAT, 1/4 ZINC
26	261	16	WASHER, FLAT, 5/8 ZINC
28	592	11	BOLT, CARRIAGE 3/8-16 X 1 ZINC
29	622	1	NUT, TOPLOCK 1/4-20 ZINC
30	737	4	BOLT, HH 8-1.25 X 20MM 8.8 ZINC
32	761	3	ZERK, 90°, 1/4-28 STRAIGHT PIPE THREAD
34	812	2	BOLT, HH 5/8-11 X 3 GR8 ZINC
35	813	8	BOLT, 1/2-20 UNF X 1-1/2 GR5 ZINC
36	814	3	BOLT, 1/4 X 1-3/4 GR5 ZINC
37	815	8	BOLT, HH 5/8-11 X 2-1/4 GR8 ZINC
38	817	8	NUT, CENTERLOCK, 5/8-11, GR8 ZINC
39	819	28	HHCS, FLANGED 1/2 X 2 G8 ZINC
40	820	28	NUT, FLANGED LOCK, 1/2-13 G8 ZINC
41	15829	1	WASHER PLATE, SAFETY CHAIN
42	15835	1	BUSHING, SAFETY CHAIN SPACER
46	27928	1	WLDMNT, LH FOLD ARM
47	27929	1	WLDMNT, RH FOLD ARM
50	28031	1	WLDMNT, RH FRAME
51	28032	1	WLDMNT, LH FRAME
54	28051	1	PLATE, 3/8" FIELD LATCH
56	28070	2	WLDMNT, FRONT AXLE
57	28073	1	ASSY, ROTARY HOE HYDRAULICS
62	590062	4	U-BOLT, 4 X 6 X 5/8 SQ. BEND, ZINC
63	590146	2	WASHER, FLAT 1" ZINC
64	590153	2	BOLT, HH 1-8 X6 -3/4 X 1-1/4 THD GR5 ZINC
65	590834	1	SPRING, CENTURY SPRING 4075
66	700208	2	WHEEL, TITAN 14L 16.1 SL, 8 BOLT RIM
67	730008	2	HUB & SPINDLE ASM, 8 BOLT
70	740024	2	LIGHT, AMBER WARNING
71	740025	2	TAIL LIGHT, RED
72	740031	1	LIGHT MODULE
75	790049	1	SAFETY CHAIN, 20,000LB
76	790051	1	JACK, 5000 LB SIDE WIND
79	800105	2	DECAL, WARNING-STAND CLEAR
80	800109	2	DECAL, RED REFLECTOR
81	800110	4	DECAL, AMBER REFLECTOR
82	800111	2	DECAL, ORANGE REFLECTOR
83	800287	7	DECAL, GREASE PIVOT POINTS



ILLUSTRATED PARTS LIST

Base Rotary Hoe Assembly

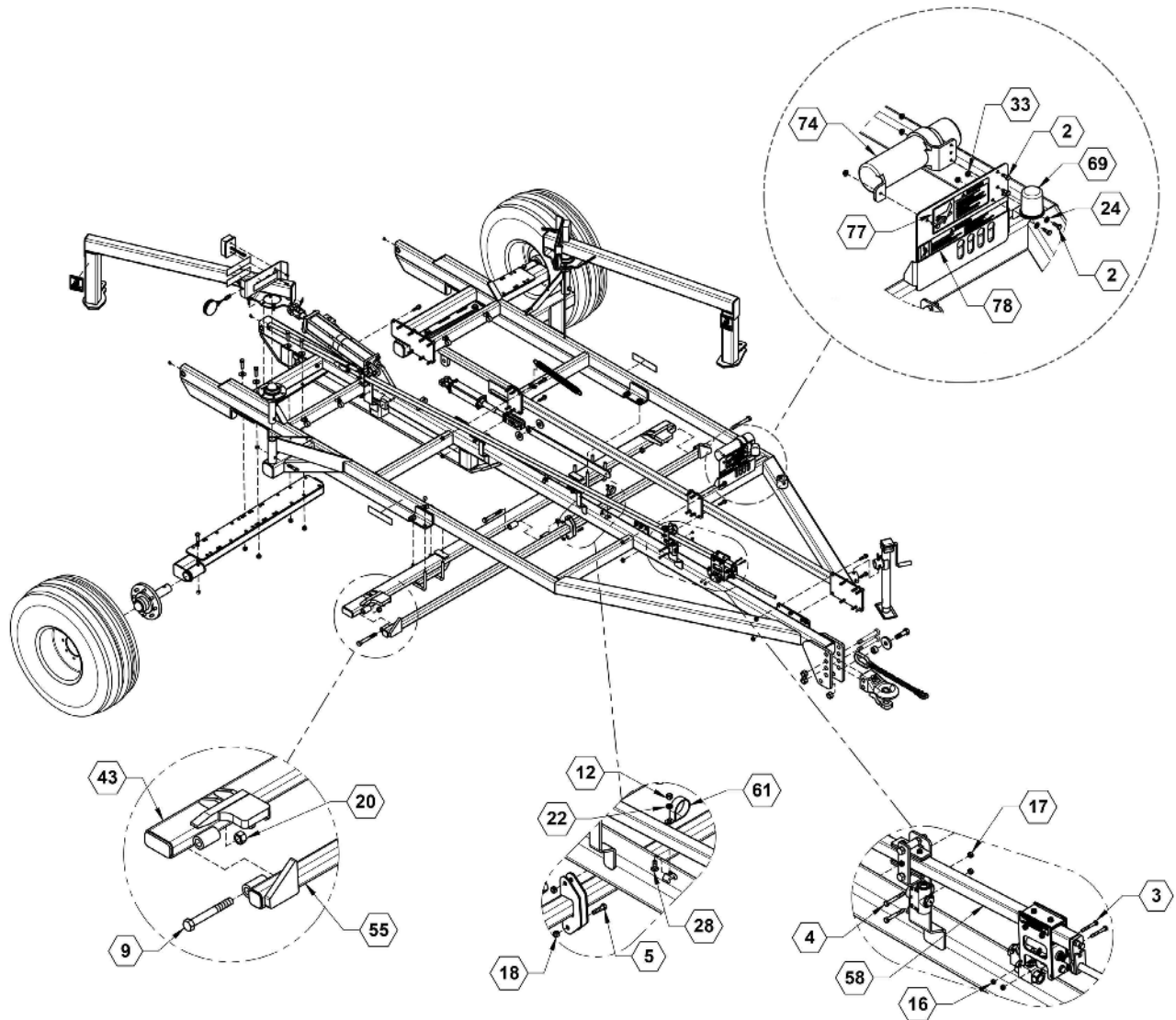



ILLUSTRATED PARTS LIST

Base Rotary Hoe Assembly Parts List

ITEM	PART NO.	QTY.	DESCRIPTION
2	101	7	BOLT, HH 1/4-20 X 3/4 GR5 ZINC
3	104	4	BOLT, HH 1/4-20 X 2 GR5 ZINC
4	118	2	BOLT, HH 5/16-18 X 2-1/2 GR5 ZINC
5	129	2	BOLT, HH 3/8-16 X 1-1/2 GR5 ZINC
9	192	3	BOLT HH 3/4-10 X 6 GR5 ZINC
12	213	11	NUT, HEX 3/8-16 ZINC
16	235	6	NUT, CENTERLOCK, 1/4-20 GR5 ZINC
17	236	2	NUT, CENTERLOCK, 5/16-18 GR5 ZINC
18	237	2	NUT, CENTERLOCK 3/8-16 ZINC
20	241	9	NUT, CENTERLOCK, 3/4-10 GR5 ZINC
22	250	11	LOCKWASHER, 3/8 ZINC
24	256	5	WASHER, FLAT, 1/4 ZINC
28	592	11	BOLT, CARRIAGE 3/8-16 X 1 ZINC
33	767	7	NUT, FLANGE, 1/4-20 ZINC
43	27490	1	WLDMNT, FIELD LOCK
55	28065	1	WLDMNT, FIELD LOCK PIVOT
58	28090	1	ASSY, DEPTH ADJUSTMENT
60	540035	6	P-CLAMP, 1-1/4"
61	540051	5	P-CLAMP, 2" W/3/8" HOLE
68	730113	2	HUB ASSEMBLY, N890
69	740018	1	LIGHT HARNESS HOLDER
74	750048	1	MANUAL HOLDER
77	800098	1	DECAL, WARNING-HYDRAULIC FLUID
78	800104	1	DECAL, WARNING-DO NOT SPEED

Base Rotary Hoe Assembly

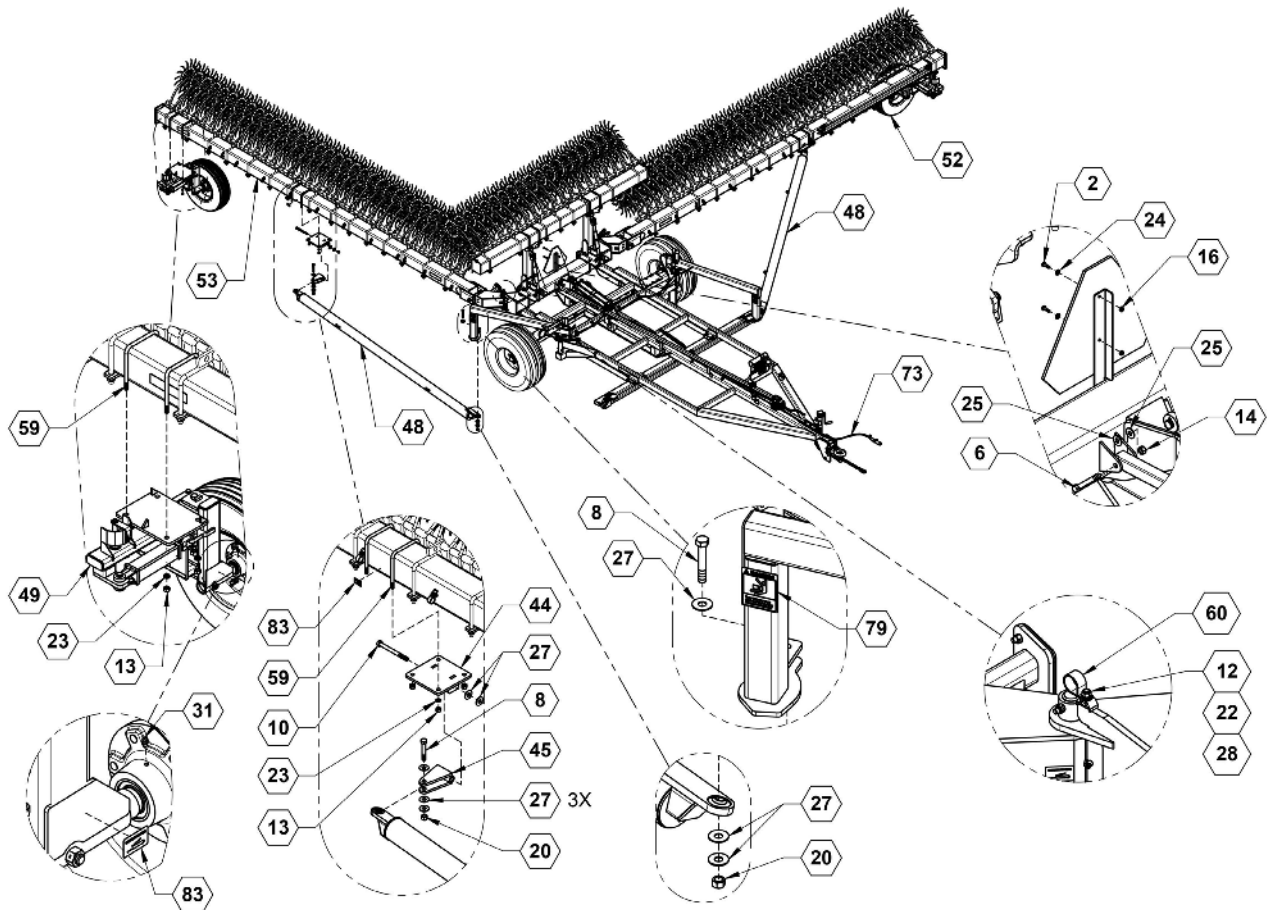



ILLUSTRATED PARTS LIST

Base Rotary Hoe Assembly Parts List

ITEM	PART NO.	QTY.	DESCRIPTION
2	101	7	BOLT, HH 1/4-20 X 3/4 GR5 ZINC
6	157	1	BOLT, HH 1/2-13 X 3-1/2 GR5 ZINC
8	189	4	BOLT, HH 3/4-10 X 4 1/2 GR5 ZINC
10	196	2	BOLT, 3/4-10 X 8 GR5 ZINC
12	213	11	NUT, HEX 3/8-16 ZINC
13	216	16	NUT, HEX 5/8-11, ZINC
14	231	1	NUT, HEX NYLOCK 1/2-13 ZINC
16	235	6	NUT, CENTERLOCK, 1/4-20 GR5 ZINC
20	241	9	NUT, CENTERLOCK, 3/4-10 GR5 ZINC
22	250	11	LOCKWASHER, 3/8 ZINC
23	253	16	LOCKWASHER, 5/8" ZINC
24	256	5	WASHER, FLAT, 1/4 ZINC
25	260	2	WASHER, FLAT, 1/2 ZINC
27	262	16	WASHER, FLAT 3/4 ZINC
28	592	11	BOLT, CARRIAGE 3/8-16 X 1 ZINC
31	759	6	ZERK, 1/4-28 STRAIGHT PIPE THREAD
44	27506	2	WLDMNT, LINKAGE MOUNT
45	27510	2	WLDMNT, LINKAGE SWING
48	28007	2	WLDMNT, LINKAGE BAR
49	28020	1	ASSY, RH WING WHEEL
52	28035	1	ASSY, LH WING WHEEL
53	28046	1	ASSY, BASE TOOLBAR
59	530172	8	U-BOLT, 7 X 7 X 5/8, ZINC
60	540035	6	P-CLAMP, 1-1/4"
73	740047	1	HARNESS, TAILLIGHT
79	800105	2	DECAL, WARNING-STAND CLEAR
83	800287	7	DECAL, GREASE PIVOT POINTS

Base Rotary Hoe Assembly

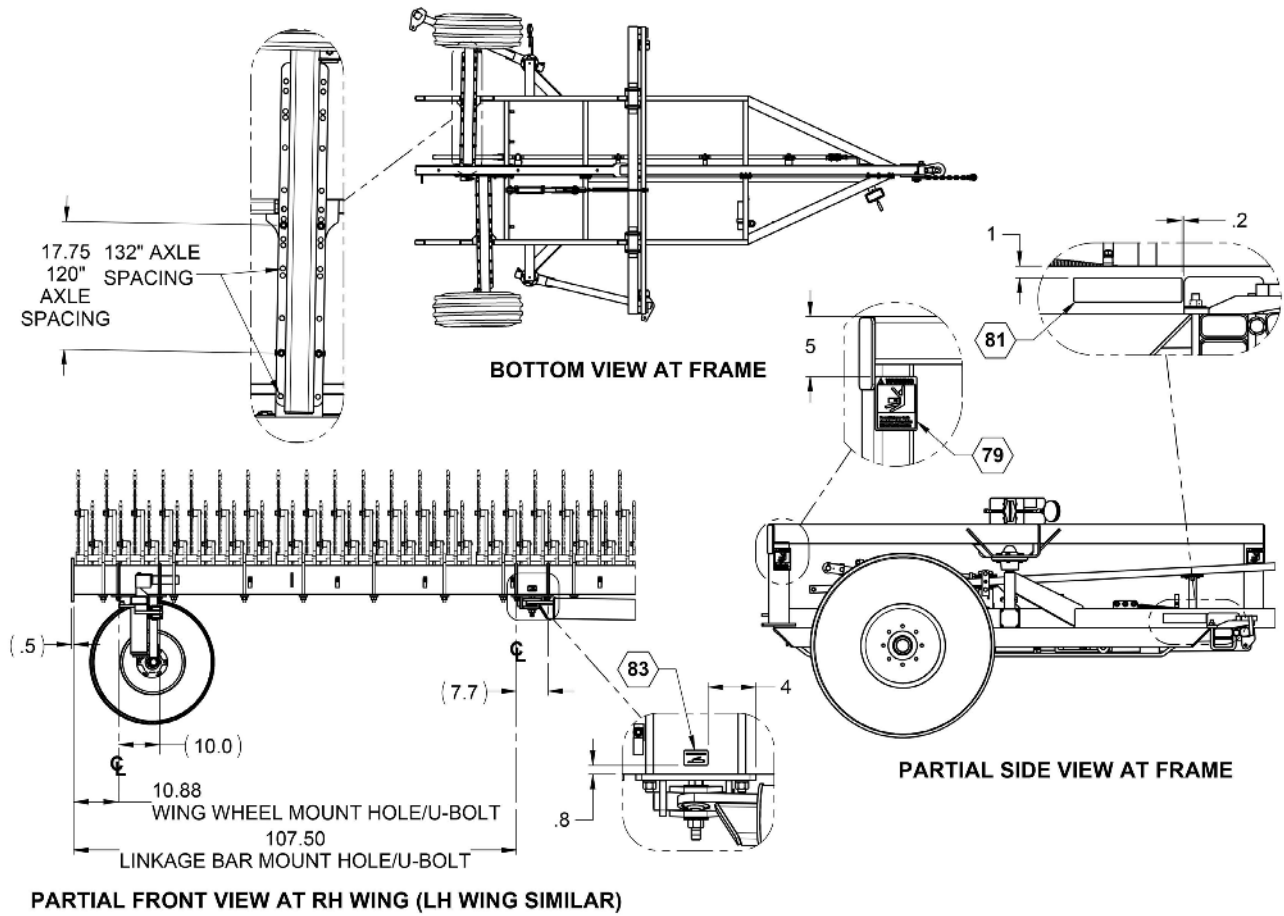



ILLUSTRATED PARTS LIST

Base Rotary Hoe Assembly Parts List

ITEM	PART NO.	QTY.	DESCRIPTION
79	800105	2	DECAL, WARNING-STAND CLEAR
81	800110	4	DECAL, AMBER REFLECTOR
83	800287	7	DECAL, GREASE PIVOT POINTS

Bare Base Toolbar Assembly

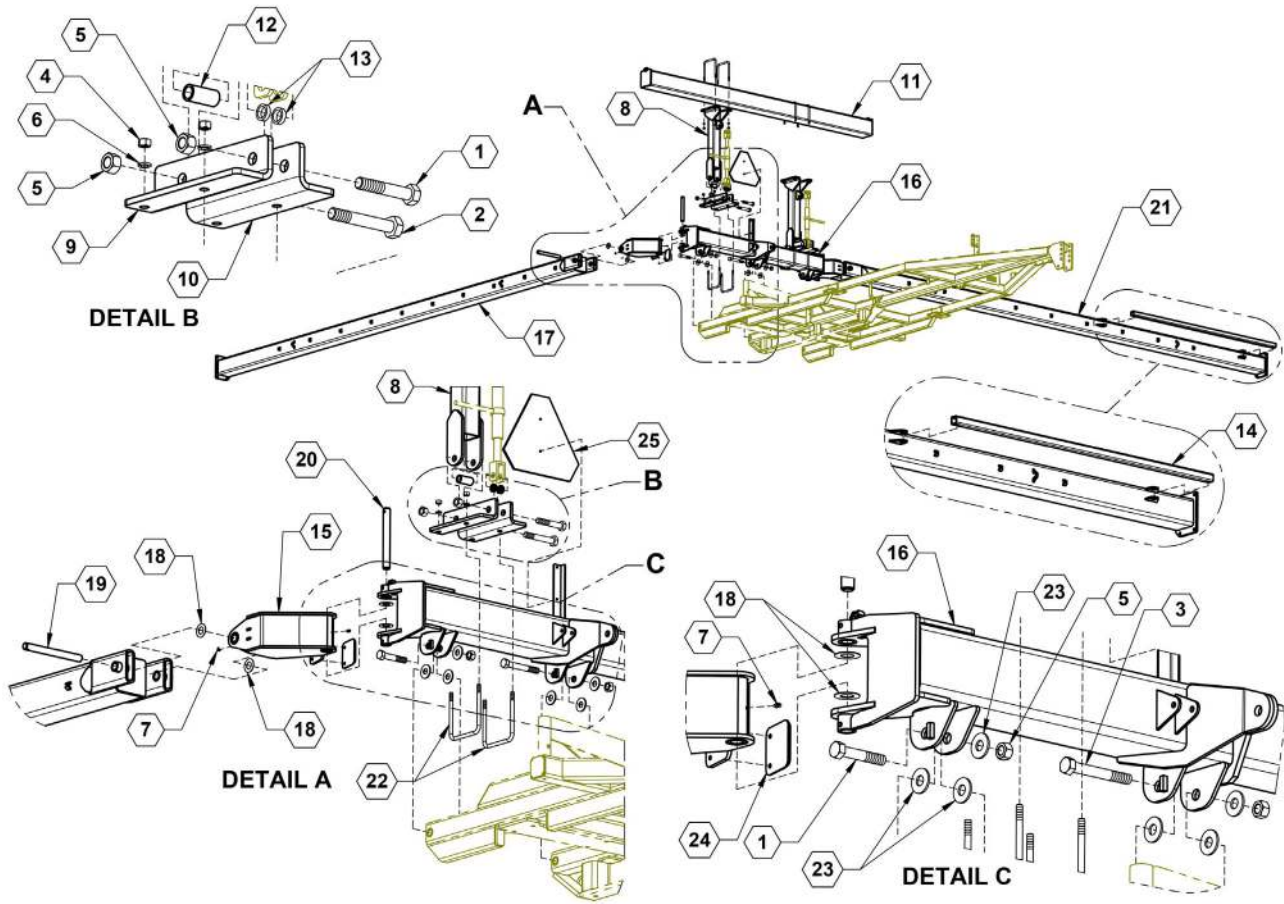



ILLUSTRATED PARTS LIST

Bare Base Toolbar Assembly Parts List

ITEM	PART NO.	QTY.	DESCRIPTION
1	205	4	BOLT, HEX 1-8X5-1/2 GR5 ZINC
2	207	2	BOLT, HH 1-8 X 6-1/2 G5 ZINC
3	209	1	BOLT, HH 1-8X7-1/2 GR5 ZINC
4	216	16	NUT, HEX 5/8-11, ZINC
5	242	7	NUT, CENTERLOCK, 1-8 ZINC
6	253	16	LOCKWASHER, 5/8" ZINC
7	761	4	ZERK, 90 DEG, 1/4-28 STRAIGHT PIPE THREAD
8	27470	2	CENTER LIFTARM, WLDMNT
9	27477	2	PLATE, CENTER LIFTARM MNT LH
10	27478	2	PLATE, CENTER LIFTARM MNT RH
11	27480	1	CENTER GANG BAR, WLDMNT
12	27537	2	BUSHING, LONG SPACER
13	27538	4	BUSHING, SHORT SPACER
14	27959	1	TUBE, CROSS BAR
15	27999	2	FLEX JOINT WLDMNT
16	28002	1	CENTER TOOLBAR WLDMT
17	28024	1	RH MAIN WING WLDMT
18	28037	8	1.5ID x 2.5OD THRUST WASHER
19	28050	2	PIN, 1.25 DIA
20	28058	2	PIVOT PIN
21	28076	1	LH MAIN WING WLDMT
22	530172	8	U-BOLT, 7 X 7 X 5/8, ZINC
23	590146	9	WASHER, FLAT 1" ZINC
24	590265	2	PLATE, WEAR
25	790017	1	SIGN, SMV PLASTIC MOLDED

Base Toolbar Assembly

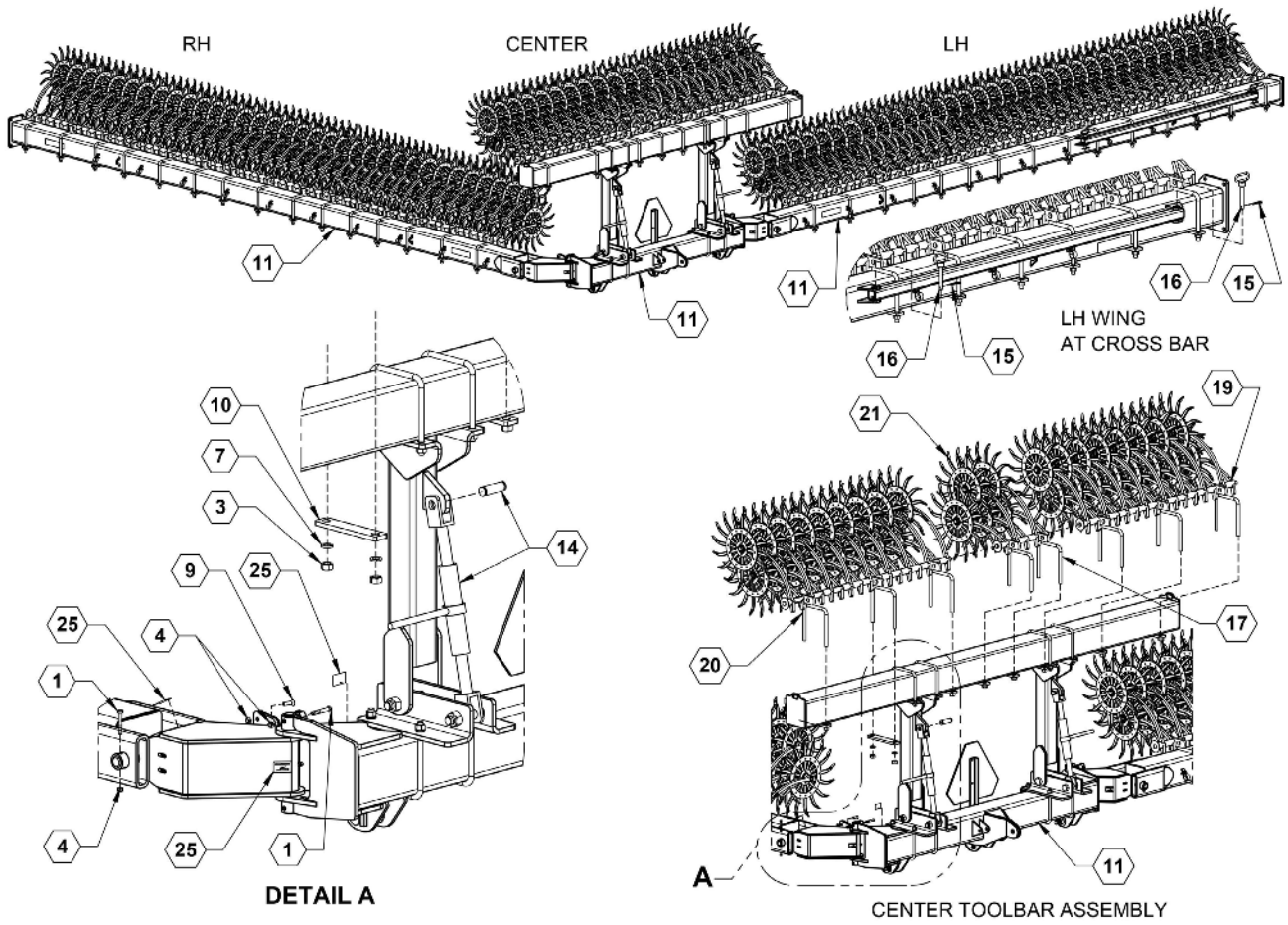



ILLUSTRATED PARTS LIST

Base Toolbar Assembly Parts List

ITEM	PART NO.	QTY.	DESCRIPTION
1	131	4	BOLT, HH 3/8-16 X 2-1/2 ZINC
3	217	76	NUT, HEX 3/4-10 G5 ZINC
4	237	8	NUT, CENTERLOCK 3/8-16 ZINC
7	254	76	LOCKWASHER, 3/4 ZINC
9	726	4	BOLT, FHSCS 3/8-16 X 1-1/4 ZINC
10	27542	38	PLATE, ROW UNIT BOLT MOUNT
11	28075	1	ASSY, BARE BASE TOOLBAR
14	590833	2	TURNBUCKLE, 24" RATCHETING
15	590017	2	PIN, HAIR CLIP, 1/8 X 3-1/8" ZP
16	790043	2	HITCH PIN, 5/8" X 4"
17	790066	1	YETTER 5 WHEEL AXLE ASSY
19	790068	1	YETTER 16 WHEEL AXLE ASSY
20	790069	1	YETTER 17 WHEEL AXLE ASSY
21	790071	174	YETTER ROTARY HOE WHEELS
25	800287	7	DECAL, GREASE PIVOT POINTS

Base Toolbar Assembly

MUST START WITH FAR LEFT WHEEL AND WORK RIGHTWARD

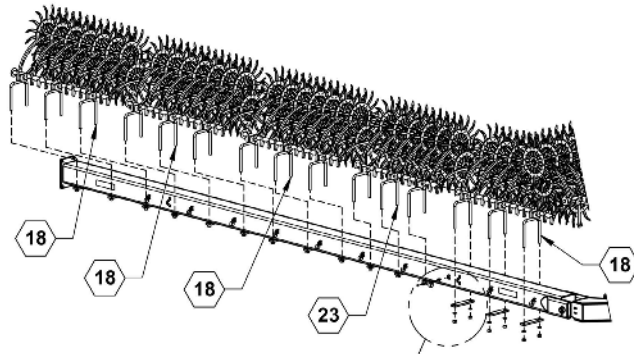

RH WING ASSEMBLY (LH OPPOSITE)

B

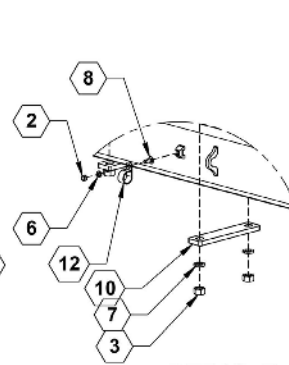

DETAIL B

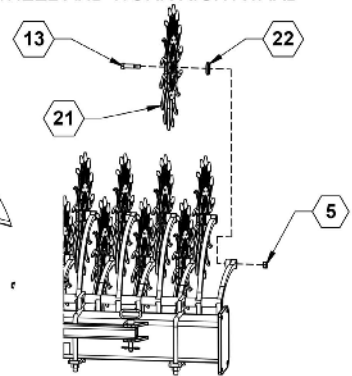

LH WING ASSEMBLY

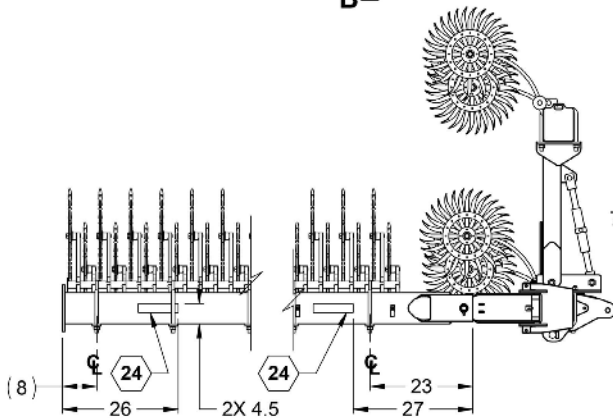

RH WING ASSEMBLY (LH OPPOSITE)

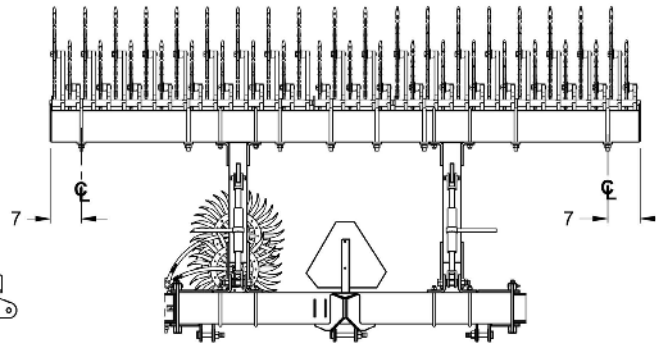

FRONT TOOLBAR ASSEMBLY



ILLUSTRATED PARTS LIST

Base Toolbar Assembly Parts List

ITEM	PART NO.	QTY.	DESCRIPTION
2	213	20	NUT, HEX 3/8-16 ZINC
3	217	76	NUT, HEX 3/4-10 G5 ZINC
5	240	174	NUT, CENTERLOCK, 5/8-11, ZINC
6	250	20	LOCKWASHER, 3/8 ZINC
7	254	76	LOCKWASHER, 3/4 ZINC
8	592	20	BOLT, CARRIAGE 3/8-16 X 1 ZINC
10	27542	38	PLATE, ROW UNIT BOLT MOUNT
12	540035	20	P-CLAMP, 1-1/4"
13	590347	174	BOLT, HH 5/8-11X2.75 GR5 ZP
18	790067	8	YETTER 14 WHEEL AXLE ASSY
21	790071	174	YETTER ROTARY HOE WHEELS
22	790072	174	BEARING SHIELD, 3400-408
23	790074	2	YETTER 12 WHEEL AXLE ASSY
24	800110	4	DECAL, AMBER REFLECTOR

LH Wing Wheel Assembly

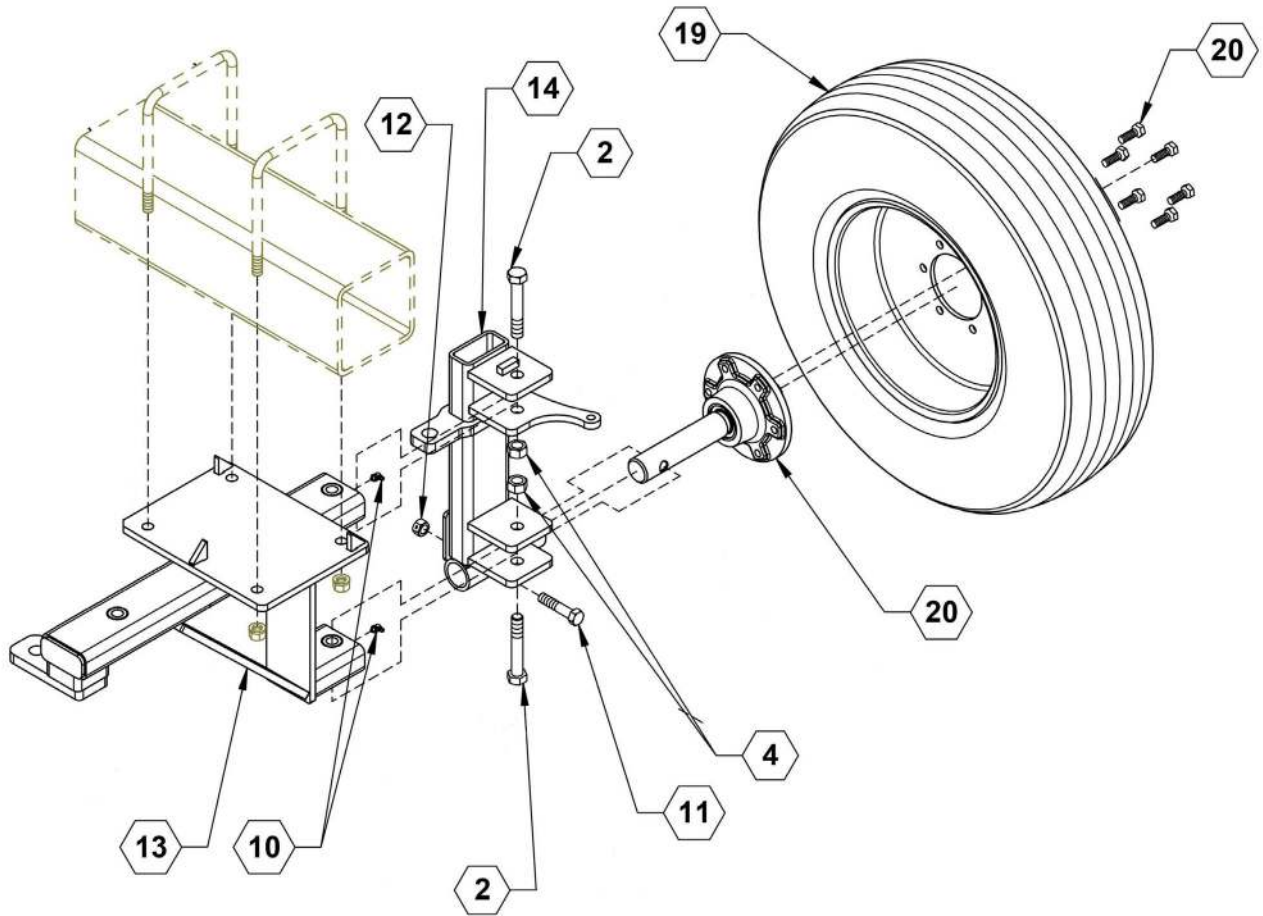



ILLUSTRATED PARTS LIST

LH Wing Wheel Assembly Parts List

ITEM	PART NO.	QTY.	DESCRIPTION
2	189	2	BOLT, HH 3/4-10 X 4 1/2 GR5 ZINC
4	233	2	NUT, HEX NYLOCK 3/4-10 ZINC
10	761	2	ZERK, 90°, 1/4-28 STRAIGHT PIPE THREAD
11	812	1	BOLT, HH 5/8-11 X 3 GR8 ZINC
12	817	1	NUT, CENTERLOCK, 5/8-11, GR8 ZINC
13	28034	1	WLDMNT, LH REAR TIRE MNT
14	28036	1	WLDMT, LH REAR TIRE PIVOT
19	700209	1	WHEEL, TITAN 9.5L 15 SL, 6 BOLT RIM
20	730106	1	HUB, 709 HUB & SPINDLE PKG

RH Wing Wheel Assembly

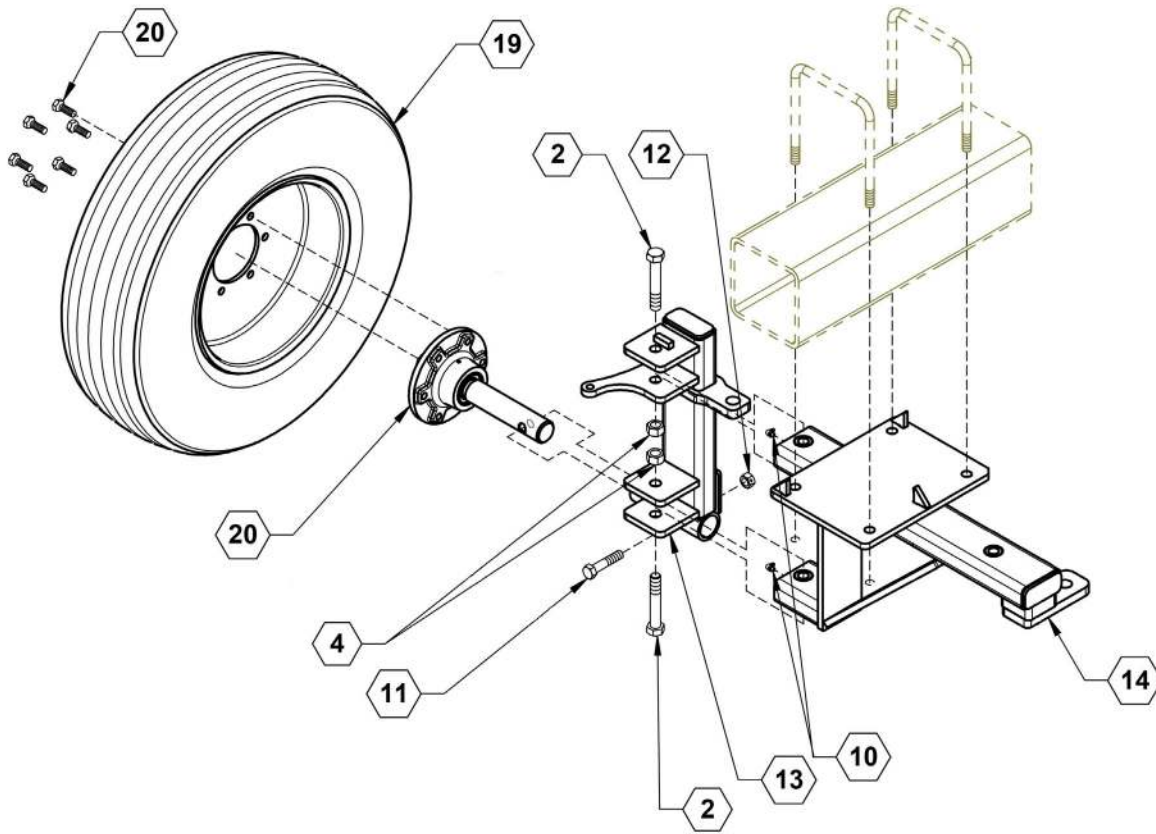



ILLUSTRATED PARTS LIST

RH Wing Wheel Assembly Parts List

ITEM	PART NO.	QTY.	DESCRIPTION
2	189	2	BOLT, HH 3/4-10 X 4 1/2 GR5 ZINC
4	233	2	NUT, HEX NYLOCK 3/4-10 ZINC
10	761	2	ZERK, 90°, 1/4-28 STRAIGHT PIPE THREAD
11	812	1	BOLT, HH 5/8-11 X 3 GR8 ZINC
12	817	1	NUT, CENTERLOCK, 5/8-11, GR8 ZINC
13	28017	1	WLDMNT, RH REAR TIRE PIVOT
14	28018	1	WLDMNT, RH REAR TIRE MNT
19	700209	1	WHEEL, TITAN 9.5L 15 SL, 6 BOLT RIM
20	730106	1	HUB, 709 HUB & SPINDLE PKG

15 Meter Toolbar

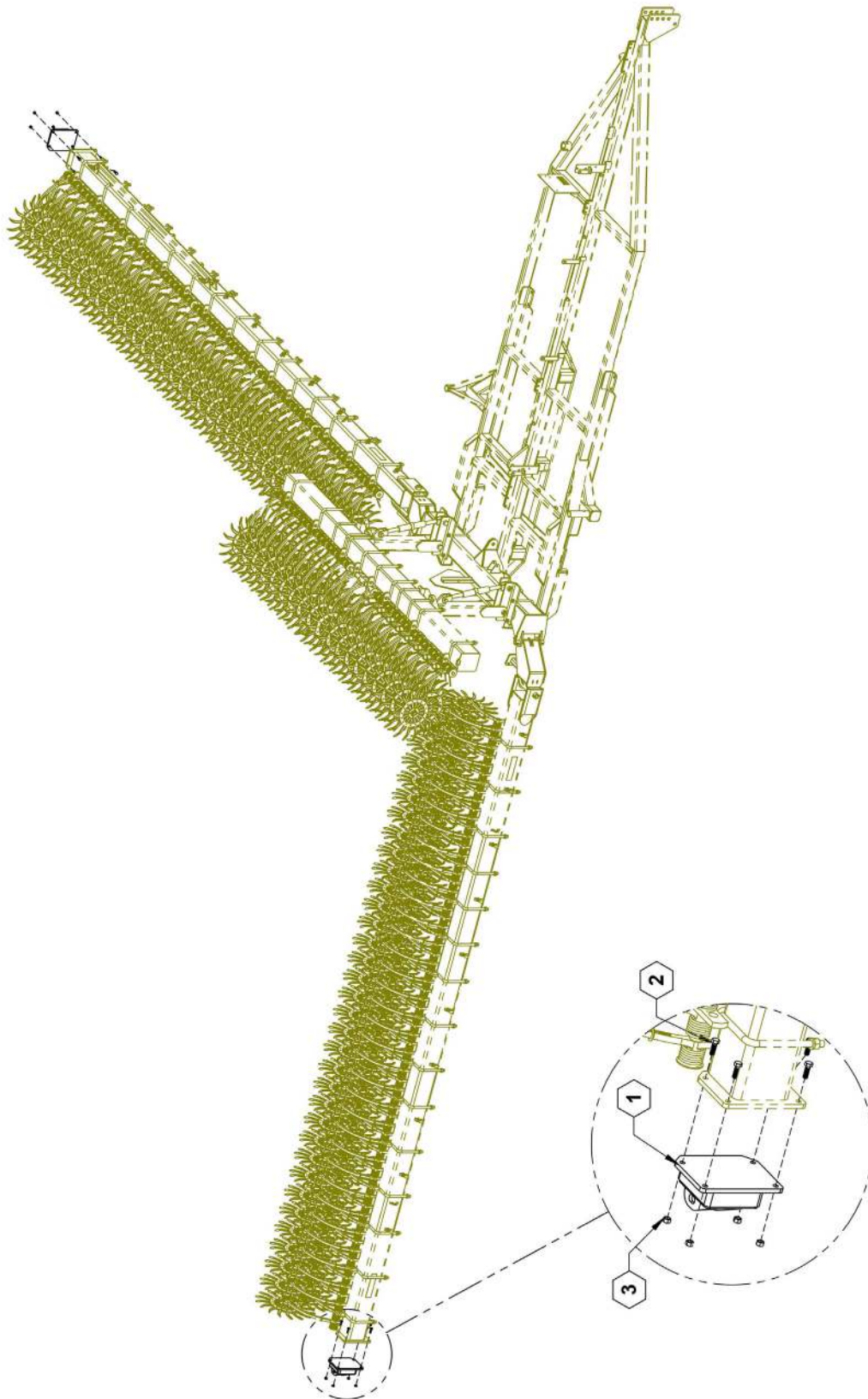



ILLUSTRATED PARTS LIST

15 Meter Toolbar Parts List

ITEM	PART NO.	QTY.	DESCRIPTION
1	28022	2	CROSS TUBE MOUNT
2	596153M	8	BOLT, HH 1/2-13X1-1/2 GR5 MAGNI
3	596239M	8	NUT, CENTERLOCK, 1/2-13 MAGNI

18 Meter Toolbar

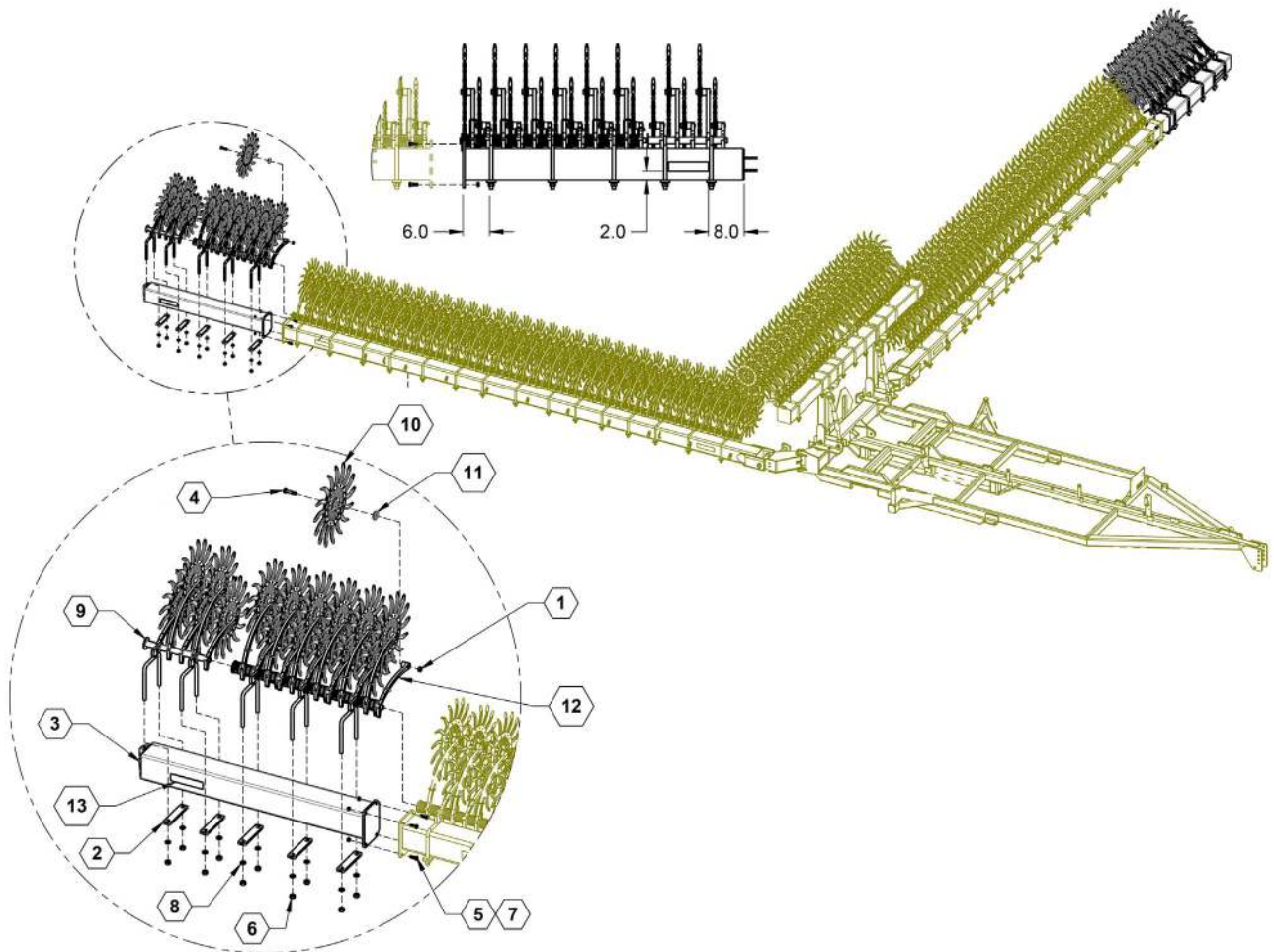



ILLUSTRATED PARTS LIST

18 Meter Toolbar Parts List

ITEM	PART NO.	QTY.	DESCRIPTION
1	240	34	NUT, CENTERLOCK, 5/8-11
2	27542	10	PLATE, ROW UNIT BOLT MOUNT
3	28028	2	18M/60FT WING EXTENSION
4	590347	34	BOLT, HH 5/8-11X2.75 GR5 ZP
5	596153M	8	BOLT, HH 1/2-13X1-1/2 GR5 MAGNI
6	596217M	20	NUT, HEX 3/4-10 G5 MAGNI
7	596239M	8	NUT, CENTERLOCK, 1/2-13 MAGNI
8	596254M	20	LOCKWASHER, 3/4 MAGNI
9	790066	2	YETTER 5 WHEEL AXLE ASSY
10	790071	34	YETTER ROTARY HOE WHEELS
11	790072	34	BEARING SHIELD, 3400-408
12	790074	2	YETTER 12 WHEEL AXLE ASSY
13	800110	2	DECAL, AMBER REFLECTOR

Bump Adjust Assembly

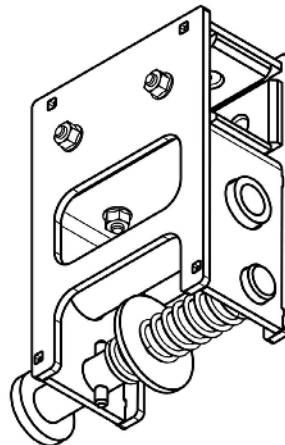
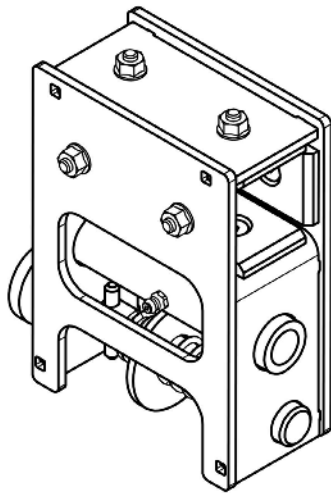
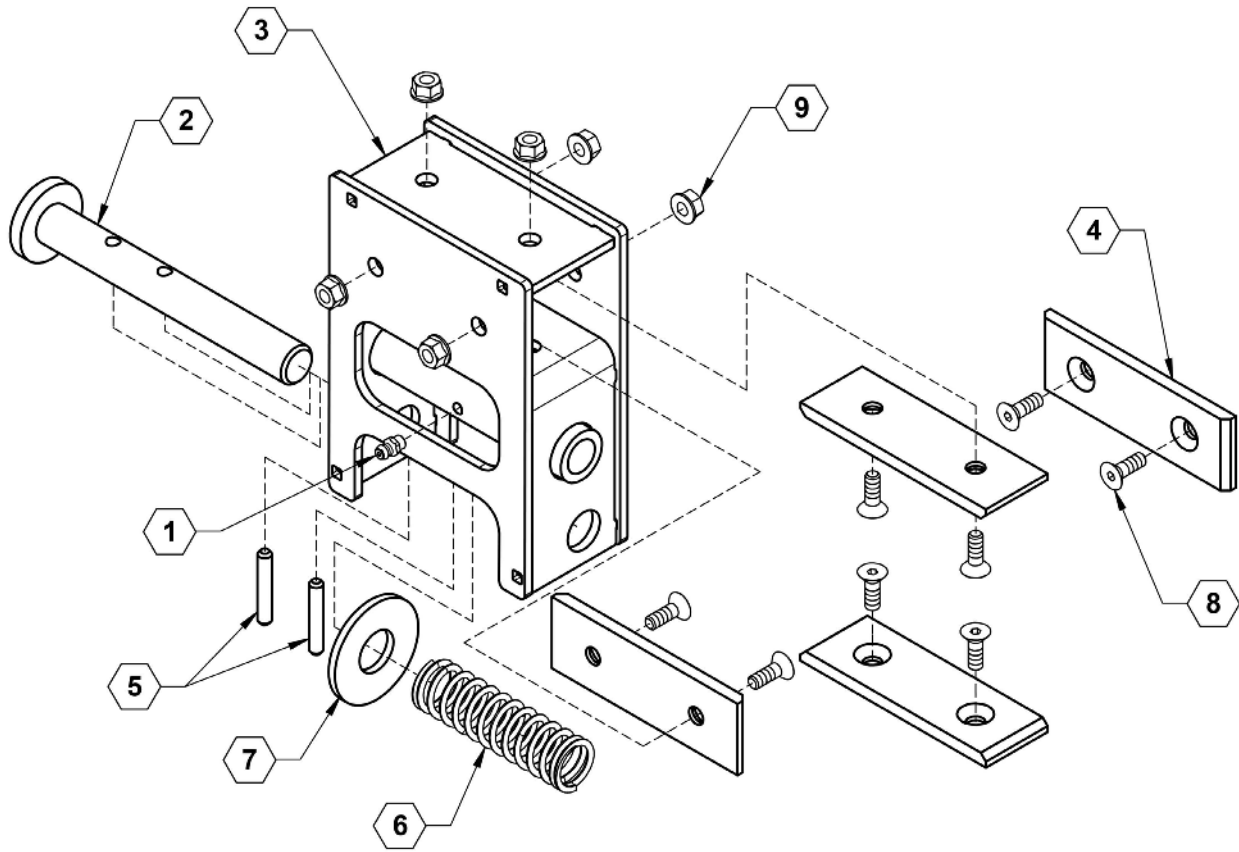



ILLUSTRATED PARTS LIST

Bump Adjust Assembly Parts List

ITEM	PART NO.	QTY.	DESCRIPTION
1	759	1	ZERK, 1/4-28 STRAIGHT
2	28087	1	PLUNGER
3	28088	1	BUMP ADJUST
4	28095	4	POLY, DEPTH ADJUST SLIDE
5	590299	2	SPRING PIN 1/4 X 1-1/2, ZINC
6	590846	1	COMPRESSION SPRING
7	596259M	1	WASHER, FLAT 3/4 MAGNI
8	596629M	8	FHSCS 1/4-20 X 3/4 MAGNI
9	596767M	8	NUT, HEX FLANGE 1/4-20 MAGNI

Row Depth Adjust Assembly

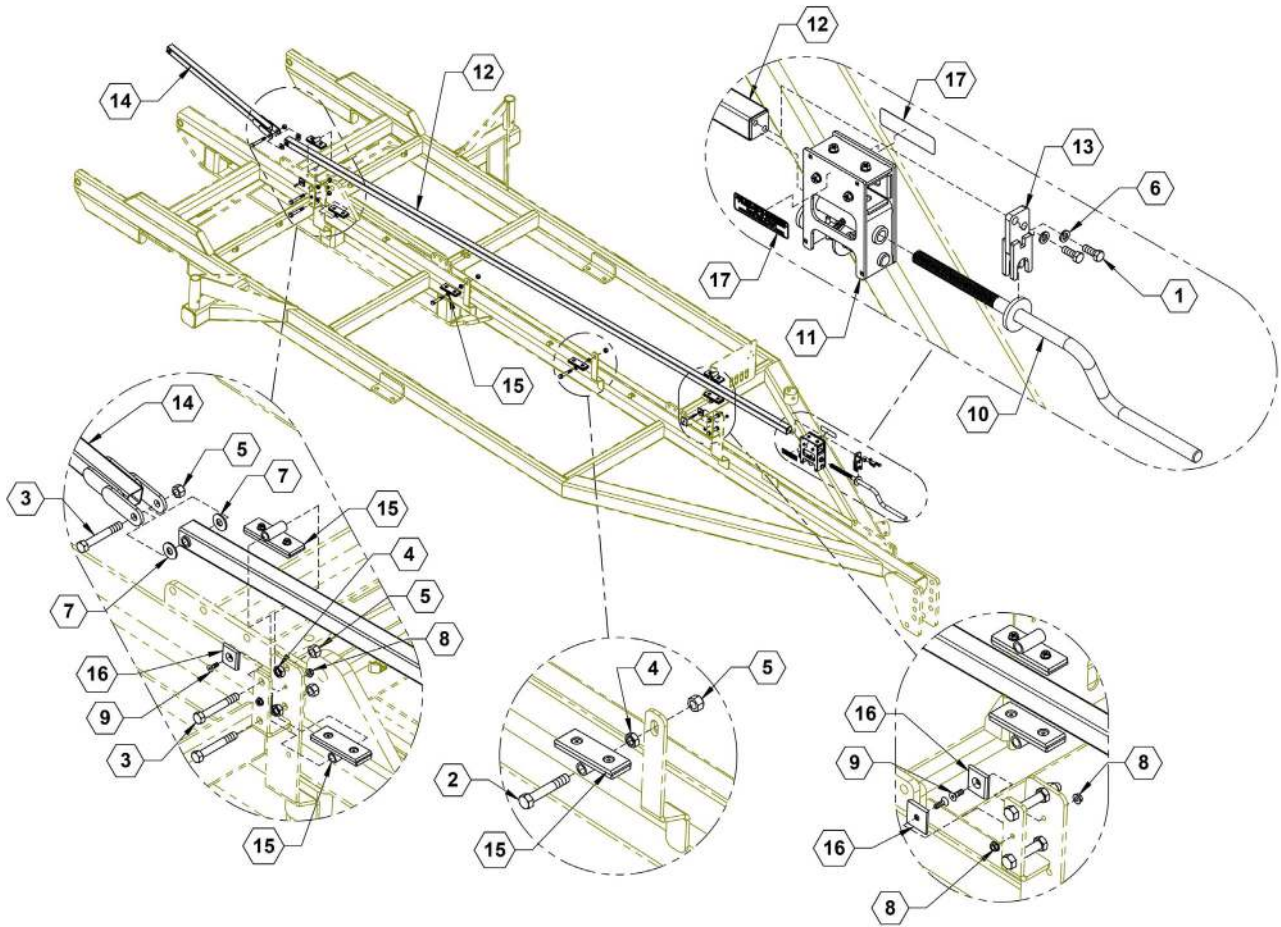



ILLUSTRATED PARTS LIST

Depth Adjust Assembly Parts List

ITEM	PART NO.	QTY.	DESCRIPTION
1	128	2	BOLT, HH 3/8-16 X 1 GR5 ZIN
2	156	2	BOLT, HH 1/2-13 X 3 GR5 ZIN
3	157	5	BOLT, HH 1/2-13 X 3-1/2 GR5 ZIN
4	223	6	NUT, HEX JAM 1/2-13 GR5 ZIN
5	231	7	NUT, HEX NYLOCK 1/2-13 ZIN
6	250	2	LOCKWASHER, 3/8 ZINC
7	260	2	WASHER, FLAT, 1/2 ZINC
8	767	4	NUT, FLANGE, 1/4-20 GR5 ZINC
9	800	4	FHSCS, 1/4-20 X 3/4 ZINC
10	28080	1	WLDMNT, ADJUST HANDLE
11	28089	1	ASSY, BUMP ADJUST
12	28091	1	WLDMNT, DEPTH TUBE
13	28096	1	WLDMNT, BASE ANCHOR
14	28100	1	WLDMNT, DEPTH FRONT TUBE
15	28102	6	ASSY, SLIDE PIVOT
16	28134	4	PAD, SIDE BRACE
17	800262	2	DECAL, DEPTH ADJUSTMENT

Slide Pivot Assembly

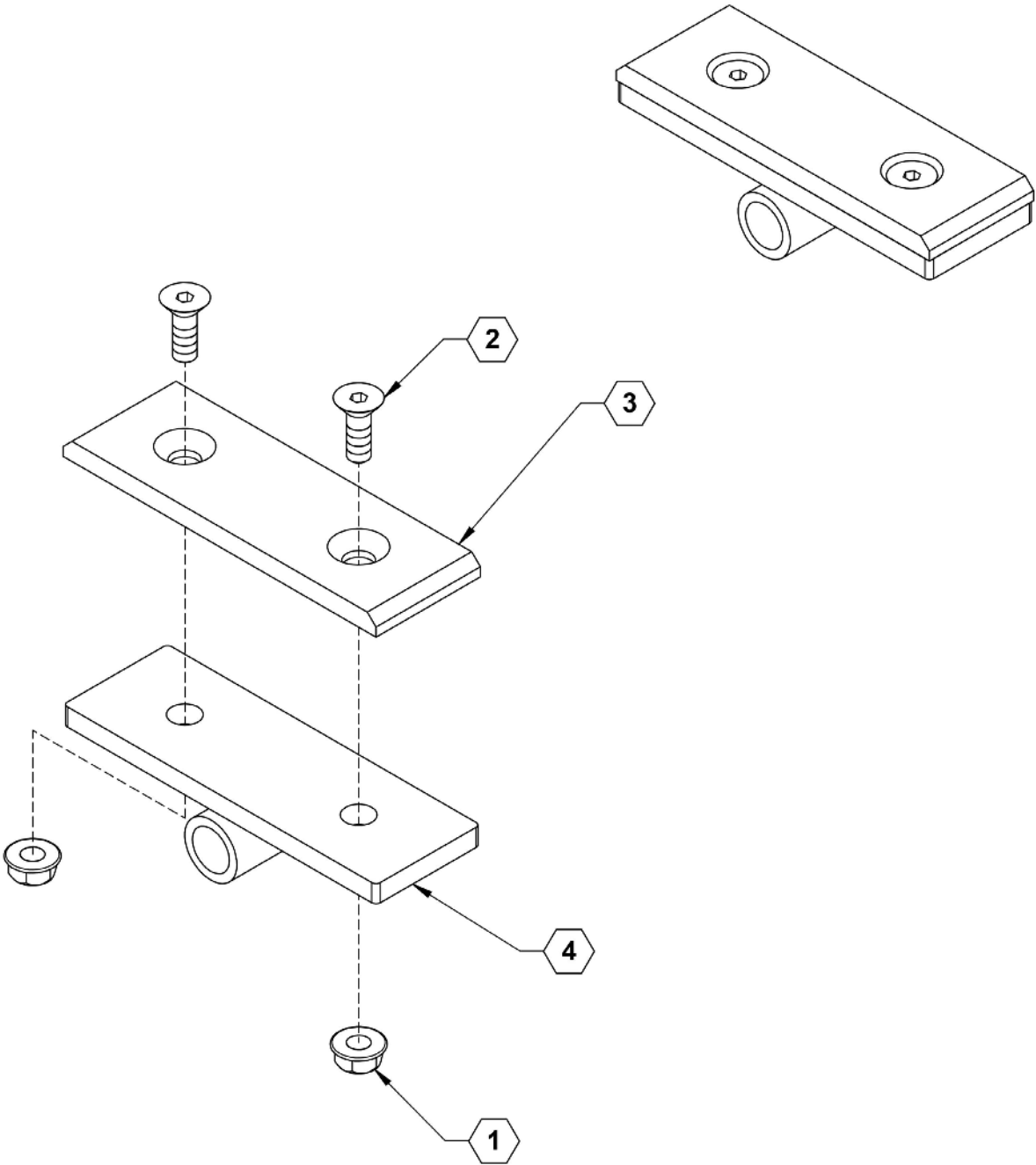



ILLUSTRATED PARTS LIST

Slide Pivot Assembly Parts List

ITEM	PART NO.	QTY.	DESCRIPTION
1	767	2	NUT, FLANGE, 1/4-20 GR5 ZINC
2	800	2	FHSCS, 1/4-20 X 3/4 ZINC
3	28095	1	POLY, DEPTH ADJUST SLIDE
4	28103	1	WLDMNT, SLIDE PIVOT

Hub and Spindle Assembly (N709) 730106

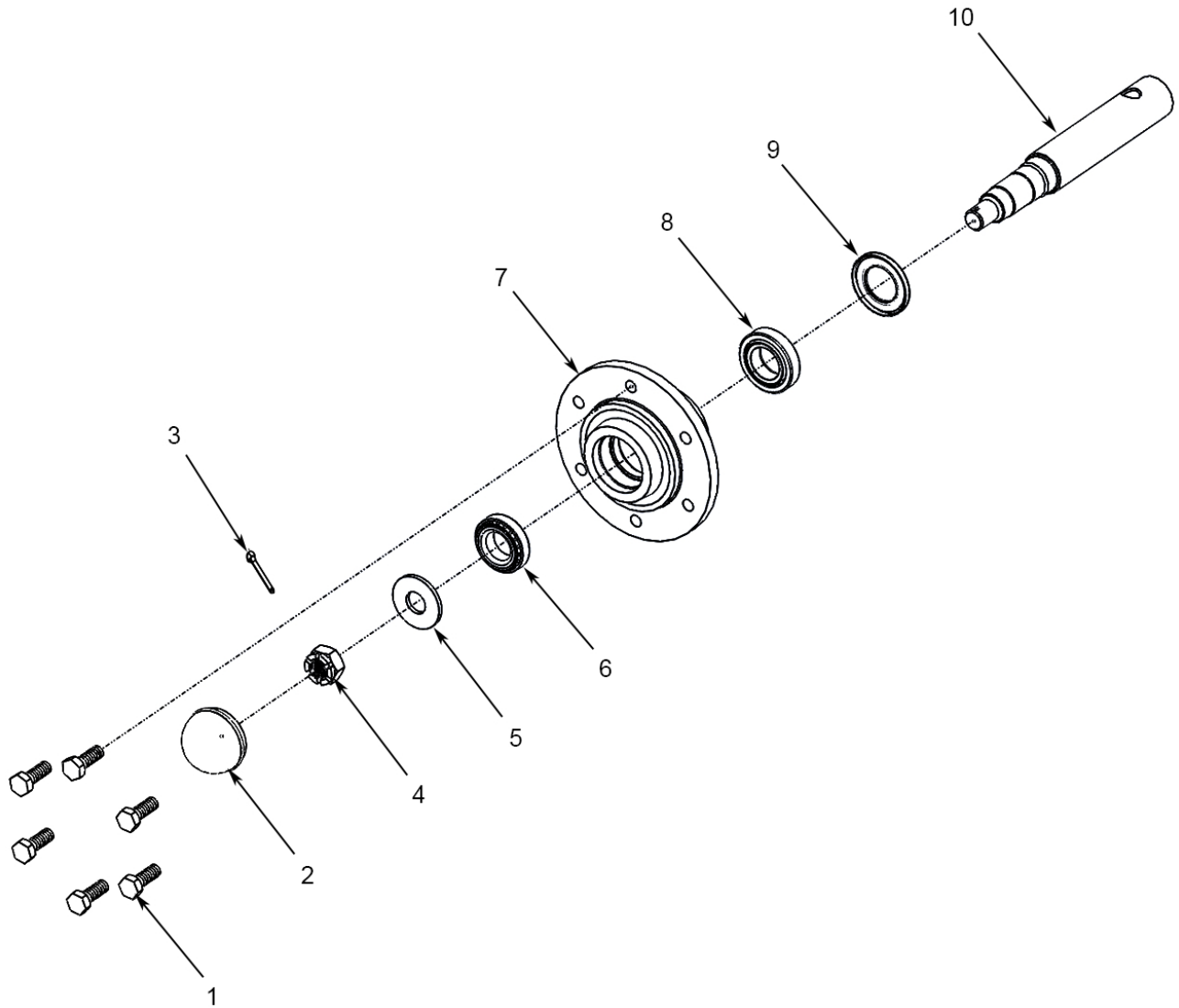



ILLUSTRATED PARTS LIST

Hub and Spindle Assembly (N709) Parts List

ITEM	VENDOR PART NO.	PART NO.	QTY.	DESCRIPTION
0		730106	1	COMPLETE HUB AND SPINDLE ASSEMBLY (N709)
1	943549		6	BOLT
2	909905		1	CAP
3	N/A	N/A	1	COTTER PIN
4	912952		1	NUT
5	913683		1	WASHER
6	LM67048		1	OUTER CUP AND CONE BEARING
7*	730106		1	HUB N709
8	LM48510		1	INNER CUP AND CONE BEARING
9	906283		1	SEAL
10*	730106		1	SPINDLE
				* INCLUDED WITH 730106

Hub and Spindle Assembly (N45-8) 730008

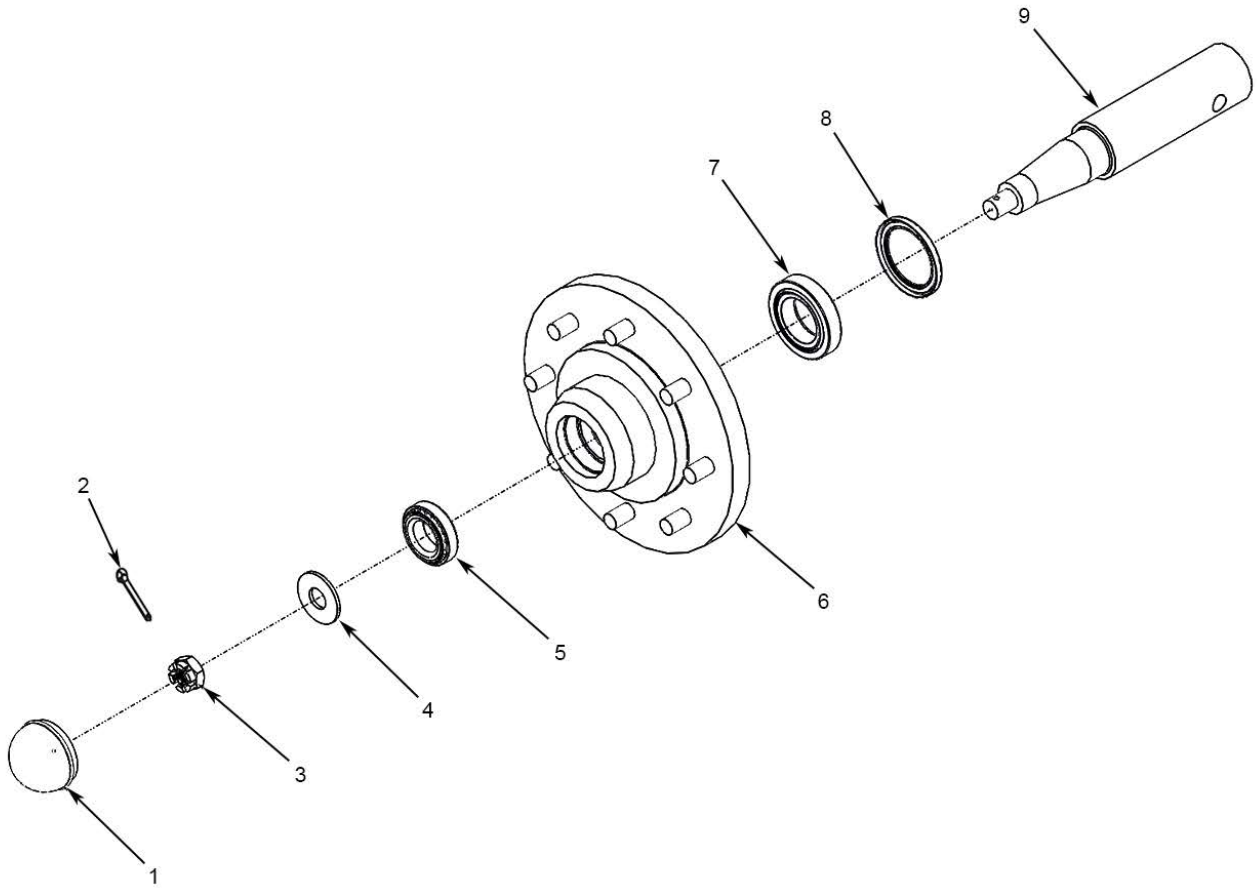



ILLUSTRATED PARTS LIST

Hub and Spindle Assembly (N45-8) Parts List

ITEM	VENDOR PART NO.	PART NO.	QTY.	DESCRIPTION
0		730008	1	COMPLETE HUB AND SPINDLE ASSEMBLY (N45-8)
1	909905		1	CAP
2	N/A	N/A	1	COTTER PIN
3	912953		1	NUT
4	913616		1	WASHER
5	LM67048		1	OUTER CUP AND CONE BEARING
6	730008		1	HUB
7	LM603049		1	INNER CUP AND CONE BEARING
8	906297		1	SEAL
9	07-08400		1	SPINDLE

Rotary Hoe Wheel Axle Assembly

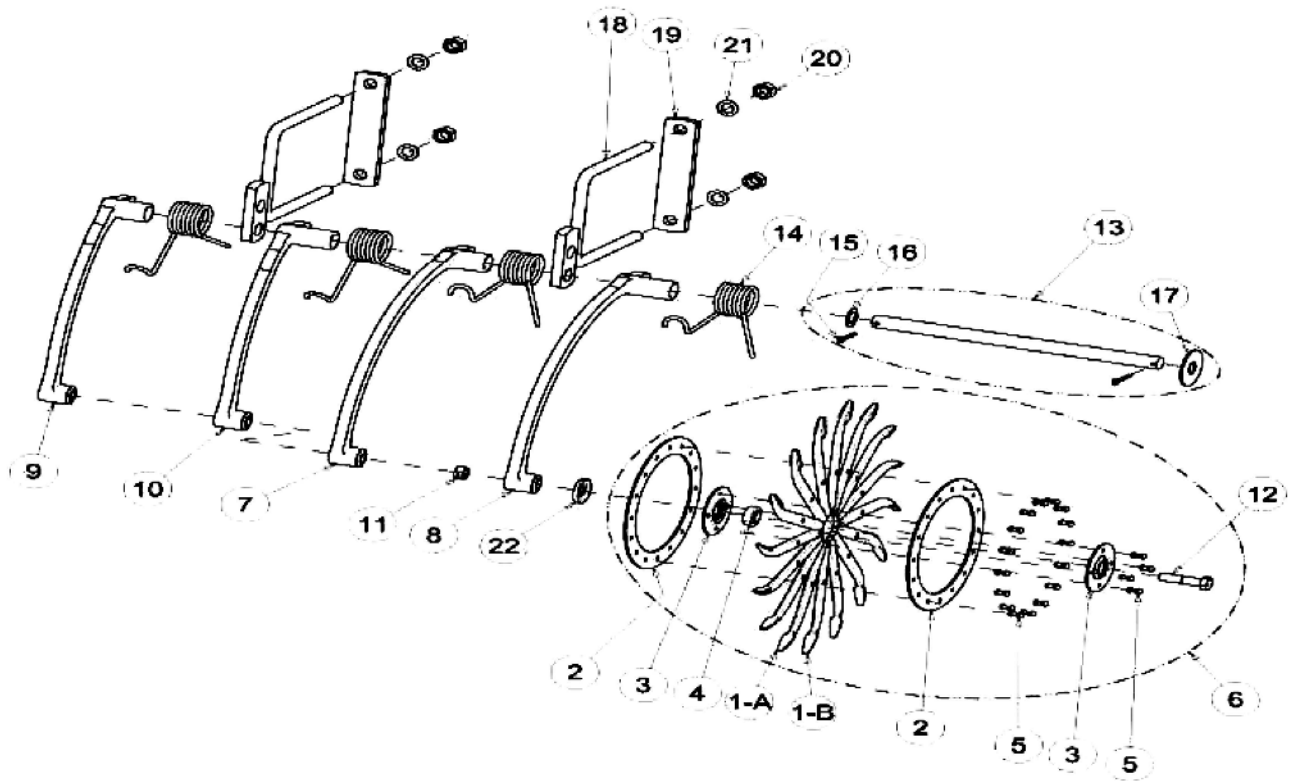



ILLUSTRATED PARTS LIST

Rotary Hoe Wheel Axle Assembly Parts List

ITEM	VENDOR PART NO.	QTY.	DESCRIPTION
1A	3400-300	12	SECONDARY HOE TOOTH
1B	3400-201	4	HOE TOOTH, 2 - HOLE
2	3400-340	2	RING
3	3400-341	2	HUB
4	2550-016	1	BEARING
5	2534-106	20	RIVET, 1" X 1-1/8"
6*	790071	1	PAINTED WHEEL ASSEMBLY, BLACK
7	255-119	A/R	SHORT HUB - REAR ARM CASTING
8	2555-116	A/R	LONG HUB - REAR ARM CASTING
9	2555-118	A/R	SHORT HUB - FRONT ARM CASTING
10	2555-117	A/R	LONG HUB - FRONT ARM CASTING
11*	240	A/R	5/8"-11 LOCK HEX NUT, ZP
12*	590347	A/R	5/8"-11 X 2-3/4" HEX HEAD BOLT, GR5 ZP
13	790066	1	5 WHEEL AXLE ASSEMBLY
13	790074	1	12 WHEEL AXLE ASSEMBLY
13	790067	1	14 WHEEL AXLE ASSEMBLY
13	790068	1	16 WHEEL AXLE ASSEMBLY
13	790069	1	17 WHEEL AXLE ASSEMBLY
14	2550-716	A/R	ROTARY HOE TORSION SPRING
15	2531-125	A/R	1/4"X X1-3/4" COTTER KEY. ZP
16	2527-564	A/R	1" ID X 1-1/2" OD X 14GA M.B.
17	3400-383	A/R	3" OD X 1-1/32" ID X 1/8" WASHER
18	3500-210	A/R	7" X 9" U-BOLT & PIVOT (7" X 7" BAR)
19*	27542	A/R	7" CONNECTING PLATE
20*	596213M	A/R	3/4"-10 HEX NUT ZP
21*	596254M	A/R	3/4" MEDIUM LOCKWASHER ZP
22*	790072	A/R	BEARING SHIELD
			* NOT INCLUDED WITH SECTION ASSEMBLIES ABOVE

Hydraulic Assembly

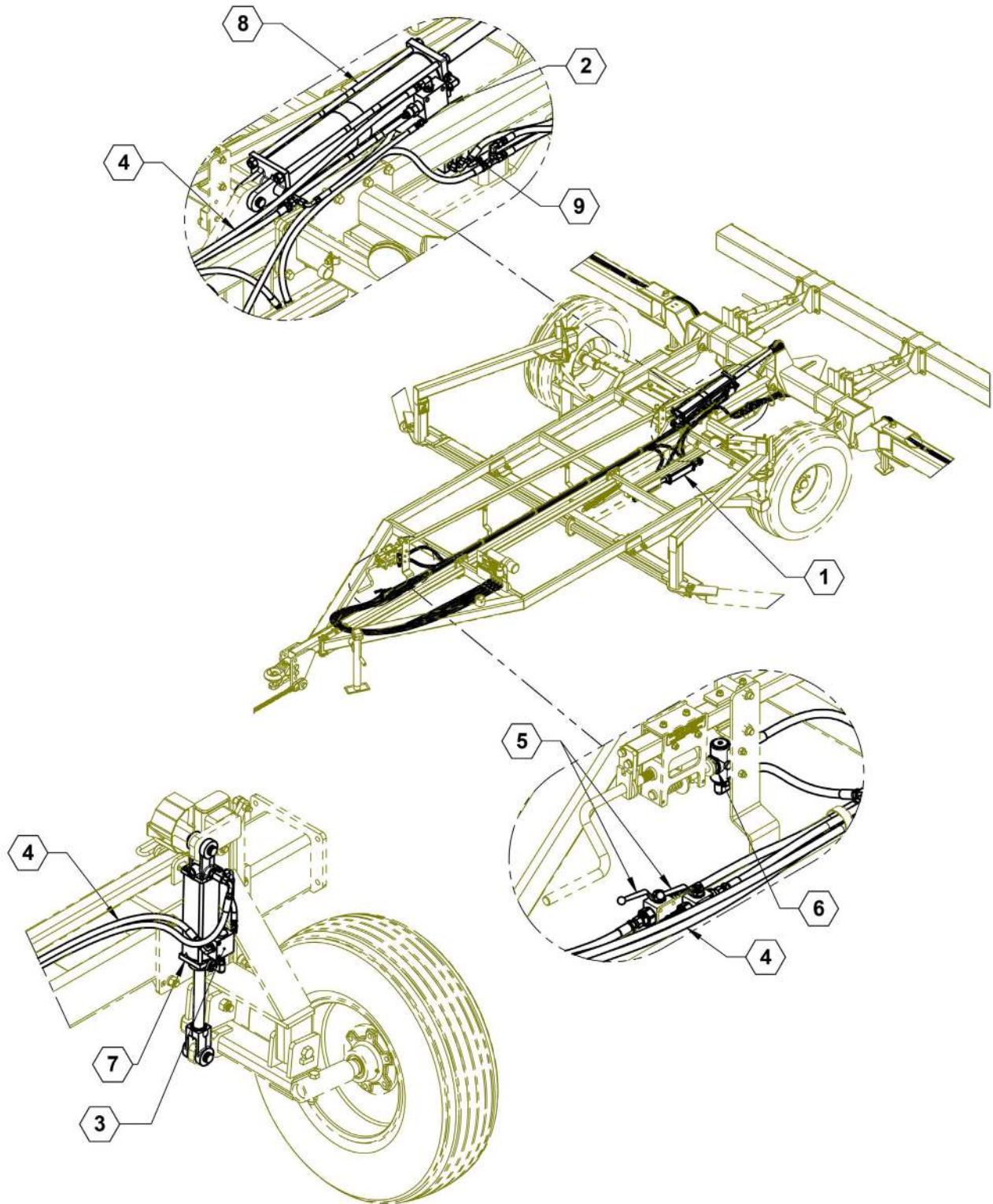

WHEEL ASSEMBLY (LH SHOWN)



ILLUSTRATED PARTS LIST

Hydraulic Assembly Parts List

ITEM	PART NO.	QTY.	DESCRIPTION
1	28072	1	ASSEMBLY, FIELD LATCH CYLINDER
1	28054	1	SLOTTED CYLINDER CLEVIS
1	620023	1	HYDRAULIC CYLINDER
2	500049	1	VALVE, COUNTERBALANCE
3	500059	2	VALVE, P.O. CHECK, SINGLE
4	600113	1	ROTARY HOE HYDRAULIC KIT
5	610153	2	VALVE, MANUAL SHUT OFF
6	610154	1	VALVE, PUSH BUTTON BLOCKING
7	620023	2	CYLINDER, 25TD08-112
8	620099	1	CYLINDER 4 X 20" 1.75" ROD 3000PSI
9	630035	1	FLOW DIVIDER

Center Cylinder Hoses

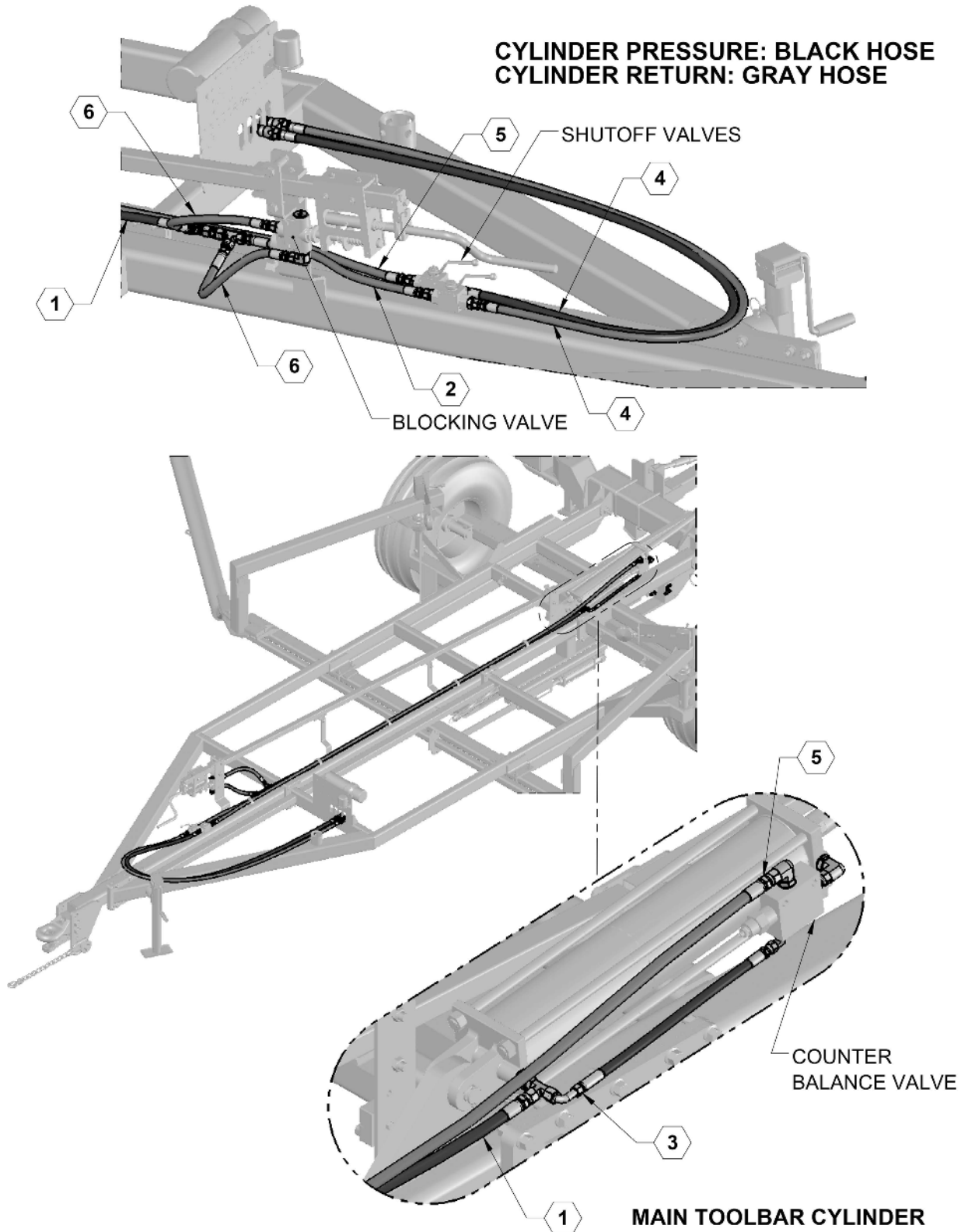



ILLUSTRATED PARTS LIST

Center Cylinder Hoses Parts List

ITEM	PART NO.	QTY.	DESCRIPTION
1	600113-2	1	HOSE ASSY, 06-6FJX-8FJX-108
2	600113-3	1	HOSE ASSY, 06-6FJX-8FJX-19.5
3	600113-4	1	HOSE ASSY, 04-6FJX90-4FJX-20
4	600113-7	2	HOSE ASSY, 06-6FJX-8MOR-89
5	600113-9	1	HOSE ASSY, 06-6FJX-6FJX-149
6	600113-10	2	HOSE ASSY, 06-6FJX-08FJX-16.5



ILLUSTRATED PARTS LIST

Field Latch Hoses

FIELD LATCH PRESSURE: BLACK HOSE
FIELD LATCH RETURN: GRAY HOSE

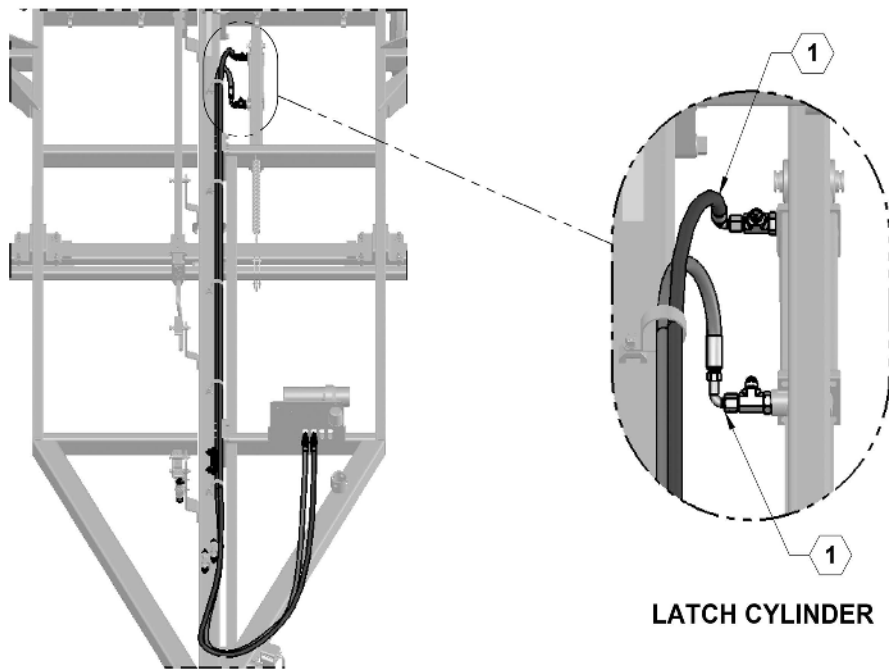
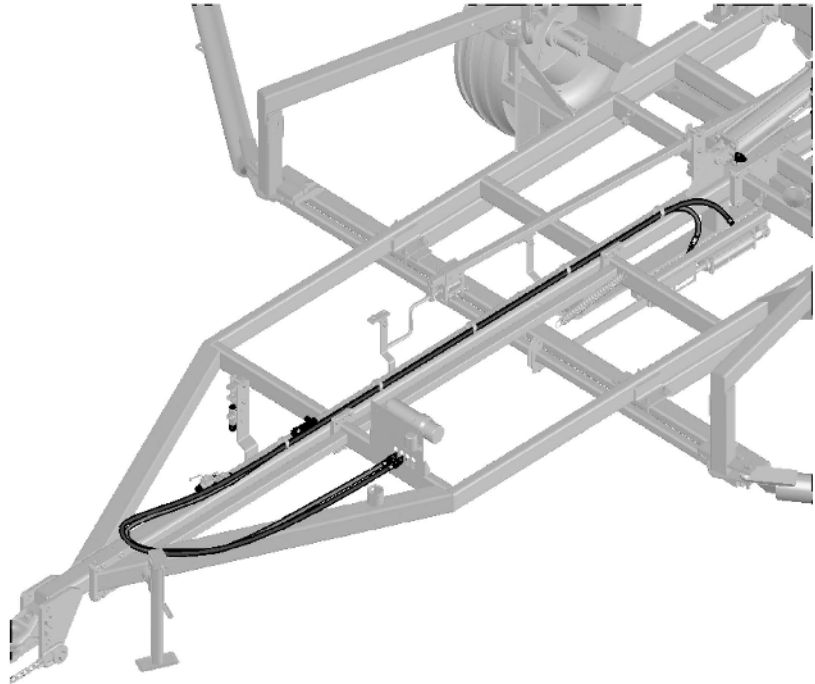

TOP VIEW

LATCH CYLINDER



ILLUSTRATED PARTS LIST

Field Latch Hoses Parts List

ITEM	PART NO.	QTY.	DESCRIPTION
1	600113-1	2	HOSE ASSY, 06-6FJX90-8MOR-220

Hydraulic Fitting Locations

CHECK VALVE ALLOWS FLOW FROM BASE END
ARROW POINTING FORWARD

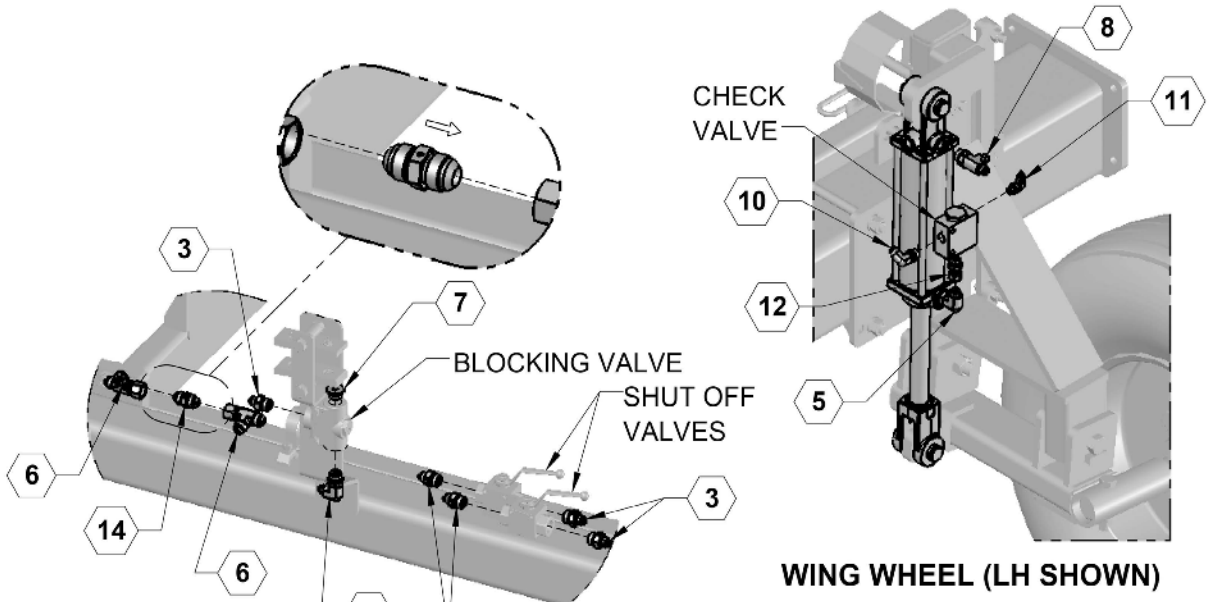

CENTER TONGUE NEAR FRONT

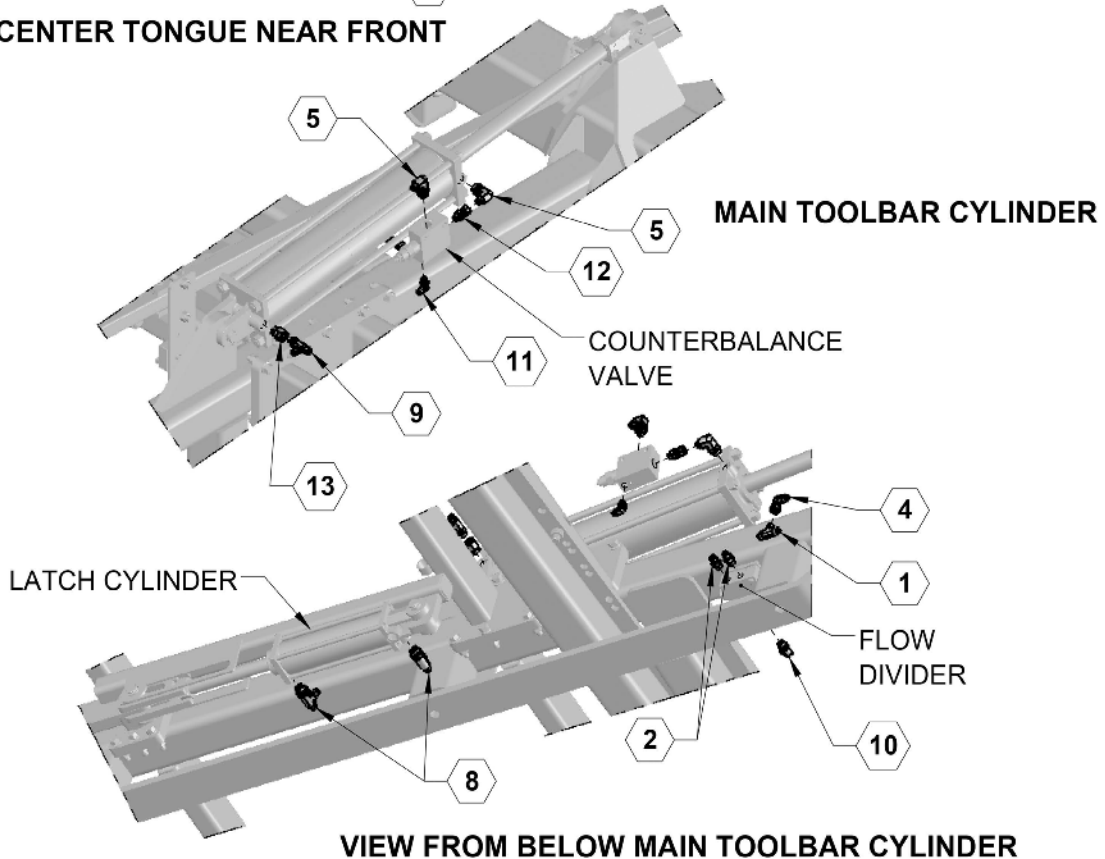



ILLUSTRATED PARTS LIST

Hydraulic Fitting Locations Parts List

ITEM	PART NO.	QTY.	DESCRIPTION
1	610005	1	JIC UNION TEE #6
2	610010	2	JIC #6 TO ORING #6
3	610011	5	JIC #6 TO ORING #8
4	610023	1	JIC #6 90 DEG
5	610030	5	JIC #6 TO ORING #8 90 DEG
6	610053	2	JIC #8 SWIVEL RUN TEE
7	610062	1	#8 O-RING PLUG
8	610066	4	#8 ORING TO JIC #6 RUN TEE
9	610074	1	JIC TO ORING #6 RUN TEE
10	610078	3	JIC #6 TO #6 ORING 90~
11	610084	3	ELBOW 90~ #4 JIC #4 O-RING
12	610113	3	#6 O-RING TO #6 JICF SWIVEL
13	610159	1	#8 MORB x #6 FORB REDUCER
14	630043	1	INLINE CHECK VALVE

Wing Fold Hoses

WING FOLD PRESSURE: BLACK HOSE
WING FOLD RETURN: GRAY HOSE

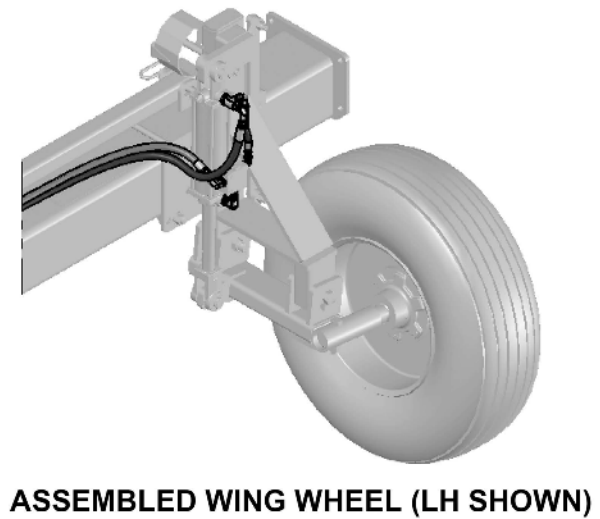
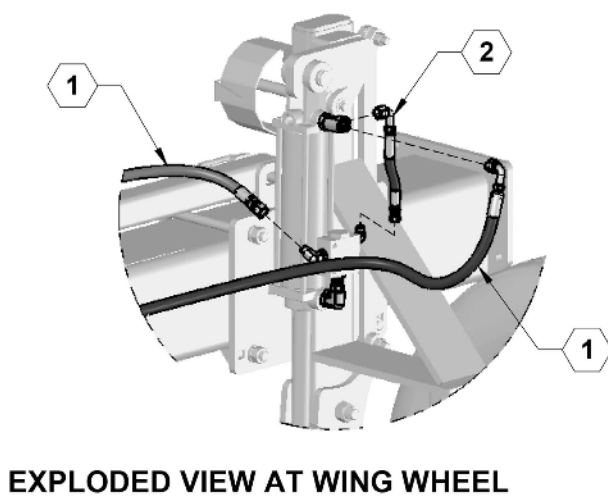
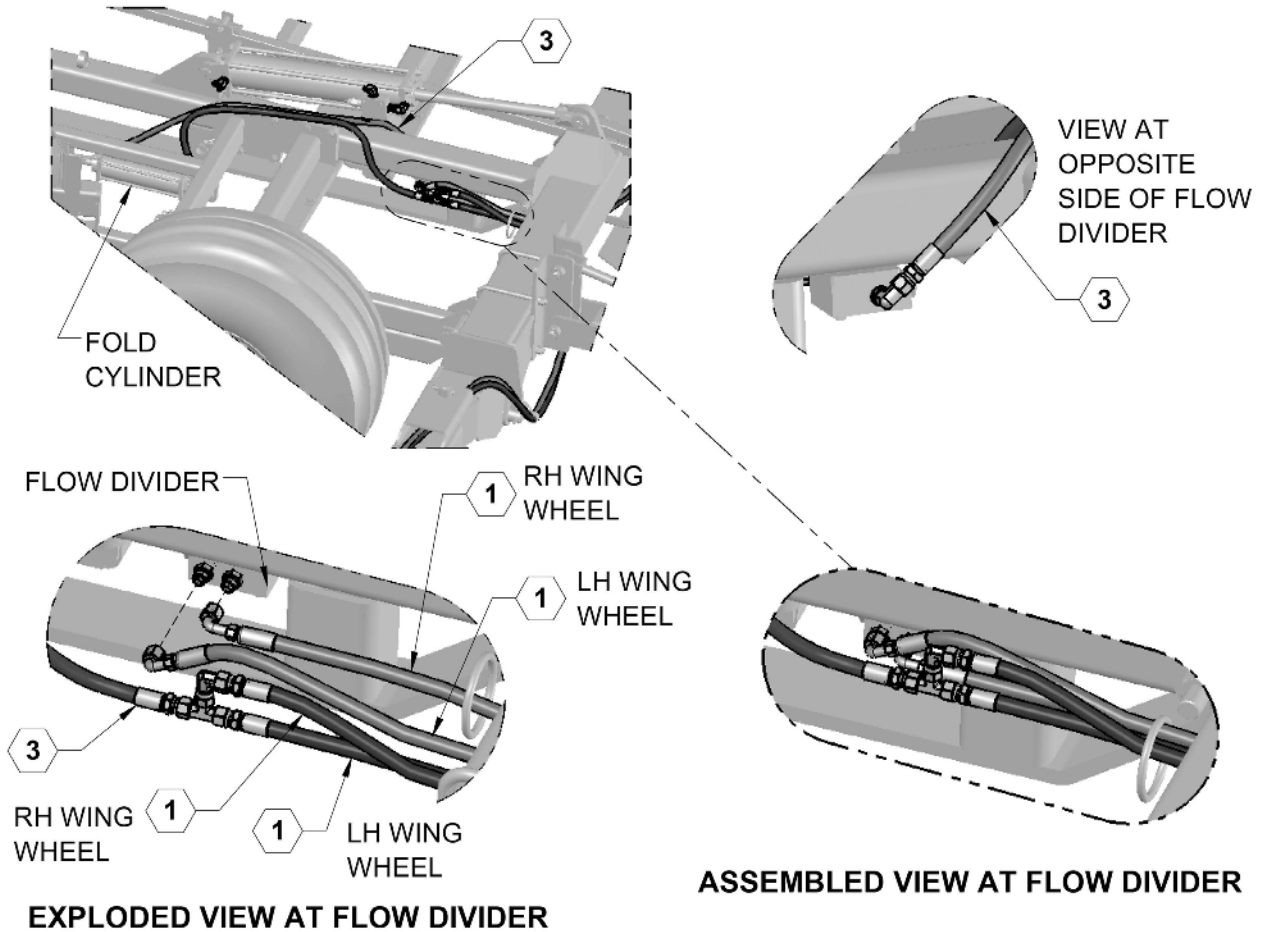



ILLUSTRATED PARTS LIST

Wing Fold Hoses Parts List

ITEM	PART NO.	QTY.	DESCRIPTION
1	600113-5	4	HOSE ASSY, 06-6FJX90-6FJX-319
2	600113-6	2	HOSE ASSY, 04-6FJX90-4FJX-8
3	600113-8	2	HOSE ASSY, 06-6FJX-6FJX-47

Hydraulic Diagram

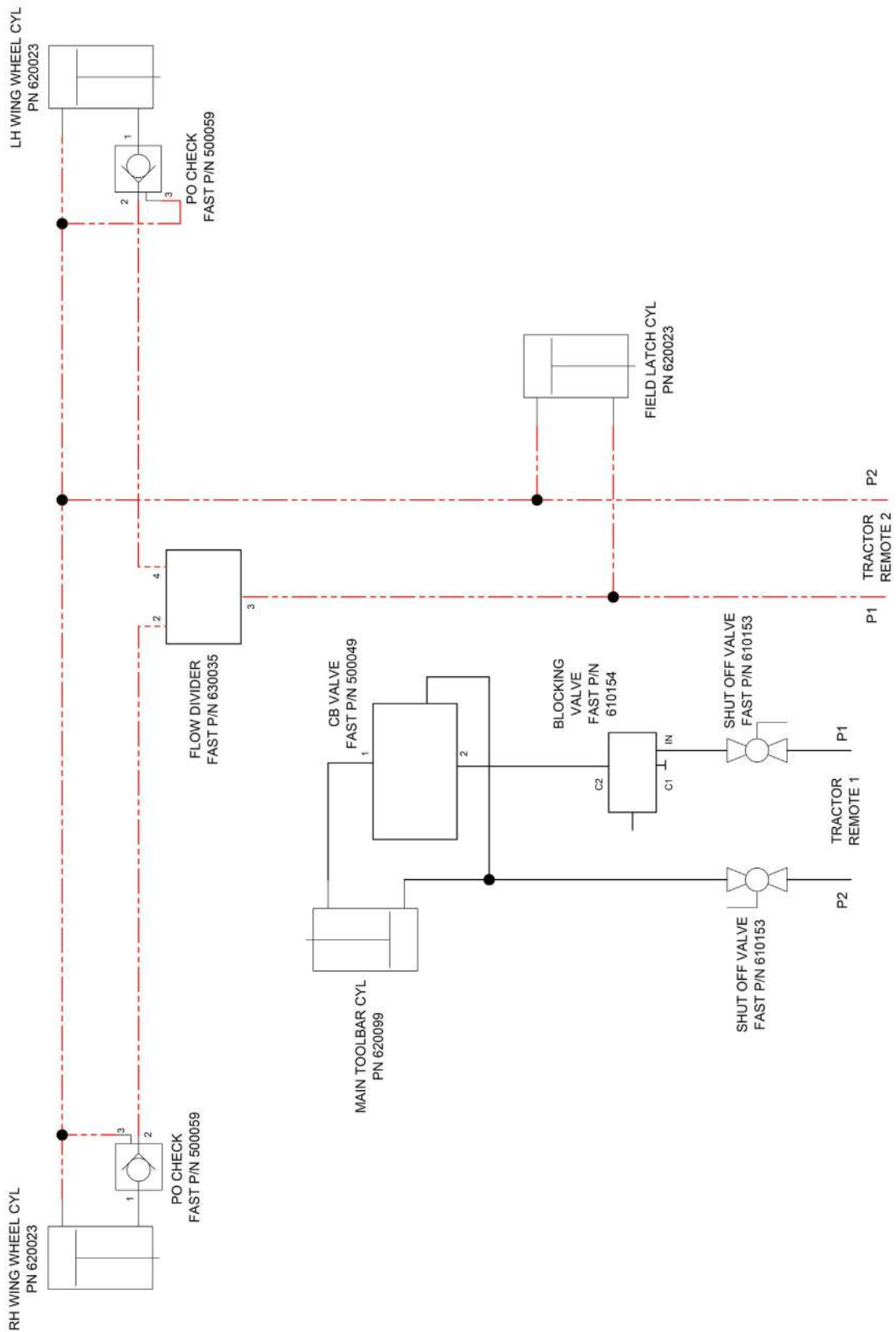



ILLUSTRATED PARTS LIST



FAST GLOBAL
SOLUTIONS



ILLUSTRATED PARTS LIST

Decals, 15 & 18 Meter Toolbar, FAST

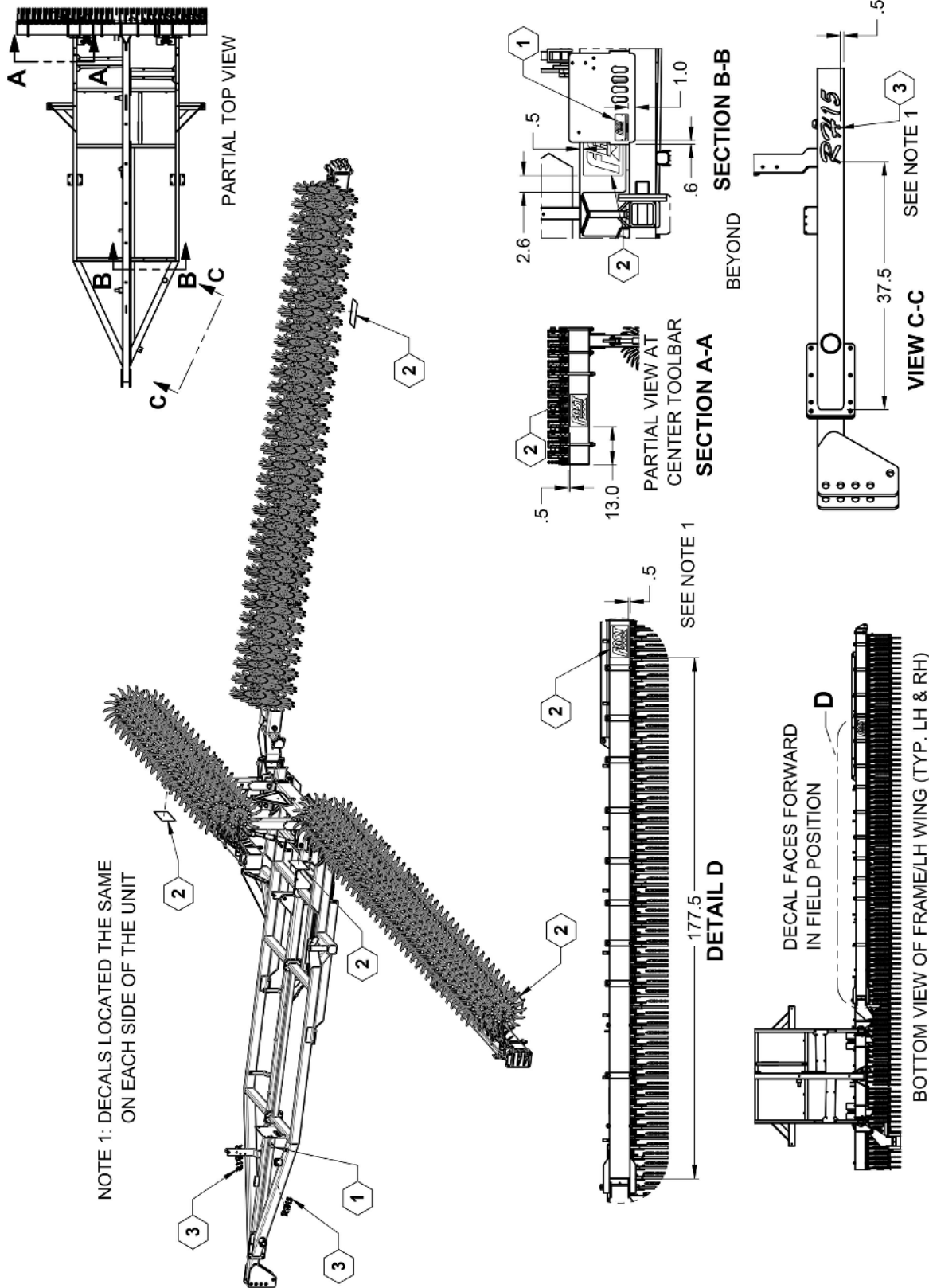



ILLUSTRATED PARTS LIST

Decals, 15 & 18 Meter Toolbar, FAST Parts List

ITEM	PART NO.	QTY.	DESCRIPTION
1	590216	1	FAST SERIAL TAG
2	800270	2	DECAL, RH15 SILVER
2	800271	2	DECAL, RH18 SILVER
3	800272	4	DECAL, FAST LOGO BLACK/GRAY



NOTES



FAST GLOBAL SOLUTIONS

4130 Commerce Boulevard

Windom, MN 56101

1-800-772-9279 Toll Free

1-507-427-3861 Voice

1-507-427-3030 Fax

www.fastsprayers.com