



Agricultural
Equipment



8-27-2019
Revision (0) Date

Liquid Fertilizer Applicator 8010N, 8013N

Operation, Maintenance & Parts Manual





TABLE OF CONTENTS

FORWARD1

SAFETY7

GENERAL INFORMATION AND OPERATING INSTRUCTIONS19

MAINTENANCE AND REPAIR57

ILLUSTRATED PARTS LISTS67

WARRANTY129

ALPHABETICAL INDEX133



FORWARD

This Operation, Maintenance & Parts Manual was written to give the owner / operator instructions on the safe operation and maintenance of the FAST AG Solutions equipment. READ AND UNDERSTAND THIS OPERATION, MAINTENANCE & PARTS MANUAL BEFORE OPERATING YOUR FAST AG SOLUTIONS EQUIPMENT.

INTRODUCTION3

 Safety Notice3

 Purpose3

 Scope3

 Terms3

 Modifications3

 Compliances3

SERIAL NUMBER LOCATION4

 Equipment Serial Number4

FEATURES AND ACCESSORIES5

 Standard Items5

 Optional Items5



INTRODUCTION

Thank you for your decision to purchase a liquid fertilizer applicator from FAST AG Solutions. To ensure maximum performance of your equipment, it is mandatory that you thoroughly read and understand the Operation, Maintenance & Parts Manual and follow its recommendations. Proper operation and maintenance are essential to prevent injury or damage and to maximize equipment life.

Continuous improvement and advancement of FAST AG Solutions' products may result in changes to your equipment that may not be reflected in this publication. FAST AG Solutions reserves the right to make product improvements at any time. Although great care has been taken to ensure the accuracy of this publication, FAST AG Solutions does not assume any liability for errors or omissions.

Safety Notice

Operate and maintain this equipment in a safe manner and in accordance with all applicable local, state, and federal codes, regulations and/or laws, and in compliance with on-product labeling and these instructions.

Make sure that all personnel have read this Operation, Maintenance & Parts Manual and thoroughly understand safe and correct operating and maintenance procedures.

Equipment Purpose

The liquid fertilizer applicator is used to safely provide a means for liquid fertilizer to be properly applied to a field. The FAST AG Solutions Liquid Fertilizer Applicator has a hydraulic powered metering pump to send liquid chemicals or fertilizer to the distribution lines on the toolbar. Coulters open the soil to receive the liquid. Nozzles mounted to the toolbar spray the fluid into the soil.

Scope Of The Document

This document outlines the specific design and performance requirements for the use of a FAST AG Solutions' liquid fertilizer applicator assembly. The word "must" in this document indicates a mandatory requirement. The use of "should" indicates a recommendation of that which is advised but not required.

Terms

The terms of this equipment can be found in the warranty section of this manual. (See WARRANTY on Page 131.)

Compliances

This FAST AG Solutions' equipment complies with the general Safety Standards specified by the American Society of Agricultural Engineers (ASAE) and the Occupational Safety and Health Administration (OSHA). Anyone who will be operating and/or maintaining the Fast Distributing Liquid Fertilizer Applicator must read and clearly understand ALL Safety, Operating and Maintenance information presented in this manual.

Figure 1

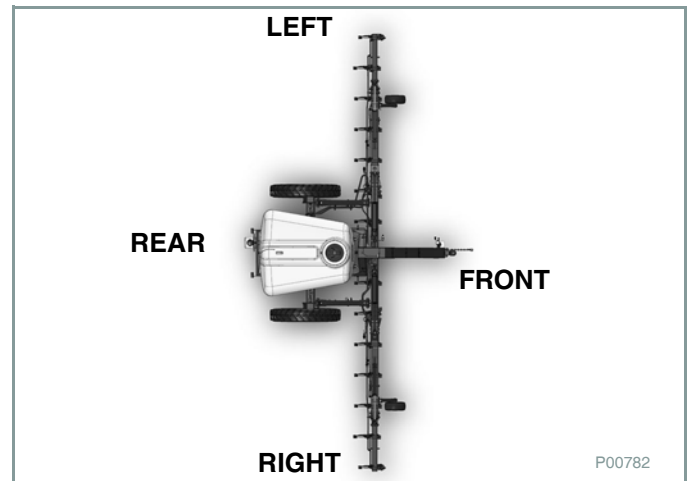

The directions left, right, front and rear, as mentioned throughout this manual, are as viewed from the rear of the equipment [Figure 1].

SERIAL NUMBER LOCATION

Equipment Serial Number

Figure 2

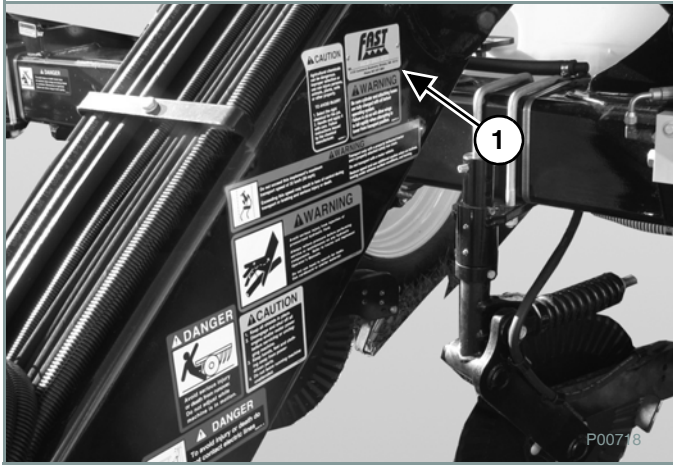

Model Number: _____

Serial Number: _____

The model number and serial number (Item 1) [Figure 2] is located on the left side of the hitch assembly. Always use the serial number of the equipment when requesting service information or when ordering parts. Early or later models (identification made by serial number) may use different parts, or it may be necessary to use a different procedure in doing a specific service operation.

MANUFACTURER'S INFORMATION

FAST AG Solutions

4130 Commerce Boulevard

Windom, MN 56101

Phone 507-427-3861

Fax 507-427-3030

Equipment Name: Liquid Fertilizer Applicator (8010N/
8013N)

Publication Number: 978

Manual Revision: 0

Publication Date: 8-27-2019

FEATURES AND ACCESSORIES

Standard Items

The liquid fertilizer applicator assembly is equipped with the following standard items:

- Standard Gauge Wheels
- 1050 or 1350 Main Gallon Tank
- Hydraulic Down Pressure
- Ace 150-206 Pump

Optional Items

The liquid fertilizer applicator assembly can be equipped with the following optional items:

- Larger Tires For 1350 380/90R 46
- Raven 440/Skytrac Control
- ISO Ready Connection
- Tall Gauge Wheel (Optional)
- Yetter Viper II Coulter
- FAST Coulters
- Bigger Flowmeter
- Pressure Transducer
- Hawkeye ISO Vari-Rate
- Vari-Rate Tip
VeriFlow
Green Leaf





SAFETY

SAFETY PRECAUTIONS9
 Safe Operation Is The Operator’s Responsibility9
 Use Safety Rules9
 Safe Operation Needs A Qualified Operator10
 Transportation Safety10
 Maintenance Safety11

FIRE PREVENTION11
 Maintenance11
 Electrical11
 Hydraulic System12
 Welding And Grinding12
 Fire Extinguishers12

SIGN-OFF FORM13
 Sign-Off Form13

SAFETY IDENTIFICATION14
 Decals14



SAFETY PRECAUTIONS

Safe Operation Is The Operator’s Responsibility

	<p>Safety Alert Symbol</p>
<p>This symbol with a warning statement means: “Warning, be alert! Your safety is involved!” Carefully read the message that follows.</p>	



WARNING

Operator must have received instructions before operating this machine. Untrained operators can cause injury or death.

W-2013-001

IMPORTANT

This notice identifies procedures which must be followed to avoid damage to the machine.

I-2013-001



DANGER

The signal word DANGER on the equipment and in the manuals indicates a hazardous situation which, if not avoided, will result in death or serious injury.

D-2013-001



WARNING

The signal word WARNING on the equipment and in the manuals indicates a potentially hazardous situation which, if not avoided, could result in death or serious injury.

W-2013-007

The FAST AG Solutions equipment must be in good operating condition before use.

Use Safety Rules

- Read and follow instructions on the equipment and in the equipment’s Operation, Maintenance & Parts Manual before operating.
- In addition to the design and configuration of equipment, hazard control and accident prevention are dependent upon the awareness, concern, prudence and proper training of personnel involved in the operation, transport, maintenance and storage of equipment.
- Check that the equipment is securely fastened to the tow vehicle (if required).
- Make sure all the equipment controls are in the NEUTRAL position before operating the equipment.
- Operate the equipment according to the Operation, Maintenance & Parts Manual.
- When learning to operate the equipment, do so at a slow rate in an area clear of bystanders.
- DO NOT permit additional personnel to be in the work area when operating the equipment.
- DO NOT modify equipment.
- DO NOT make any adjustments or repairs on the equipment while the engine is running.
- Keep shields and guards in place. Replace if damaged.

SAFETY PRECAUTIONS (CONT'D)

Safe Operation Needs A Qualified Operator

For an operator to be qualified, he or she must not use drugs or alcoholic drinks which impair alertness or coordination while working. An operator who is taking prescription drugs must get medical advice to determine if he or she can safely operate a machine and the equipment.

A Qualified Operator Must Do The Following:

- Understand the Written Instructions, Rules and Regulations.
- Understand the written instructions from FAST AG Solutions in this Operation, Maintenance & Parts Manual and machine signs (decals).
- Lower machine to ground, place all controls in neutral, stop engine, set park brake, remove ignition key, and wait for all moving parts to stop before servicing, adjusting, repairing or unplugging.
- Install and secure all guards and shields before starting or operating.
- Keep hands, feet, hair and clothing away from all moving and/or rotating parts.
- Do not allow riders on applicator or tractor during operation or when transporting.
- Clear area of all bystanders, especially children, before starting or filling with chemical or fertilizer.
- Read chemical or fertilizer manufacturers warnings, instructions and procedures **before** using and *follow them exactly*.
- Do not breathe, touch or ingest chemicals or fertilizer. Always wear protective clothing and follow safe handling procedures.
- Keep safe distance from wings when folding or extending wings. Keep others away.
- Clean reflectors, SMV (Slow Moving Vehicle) emblem and lights before transporting.
- Attach securely to towing unit using a hardened pin with a retainer and a safety chain.
- Do not exceed a safe travel speed.
- Use hazard flasher on tractor and applicator when transporting.

- Keep safe distance from overhead power lines when folding or extending wings and during transport.
- Before applying pressure to hydraulic system, make sure all components are tight; make sure hoses and couplings are in good condition.
- Review safety instructions annually.

Transportation Safety

IMPORTANT

Verify main tank is empty before transporting on road.

I-2015-017

- Read and understand ALL information in Operation, Maintenance & Parts Manual regarding procedures and SAFETY when operating applicator in field and/or on road.
- Check with local authorities regarding applicator transport on public roads. Obey all applicable laws and regulations.
- Always travel at a safe speed. Use caution when making corners or meeting traffic.
- Make sure the SMV emblem and all lights and reflectors that are required by the local highway and transport authorities are in place, are clean and can be seen clearly by all overtaking and oncoming traffic.
- Daybreak and dusk are particularly dangerous: pilot vehicles are recommended.
- Be sure applicator is properly connected to towing vehicle and a retainer is used through towbar drawbar pin. Always attach a safety chain between frame and towing vehicle.
- Keep right and yield right-of-way to allow faster traffic to pass. Drive on road shoulder, if permitted by law.
- Do not exceed 20 mph (32 km/h). Reduce speed on rough roads and surfaces.
- Always use hazard warning flashers on tractor when transporting unless prohibited by law.
- Keep safe distance from overhead power lines during transport. Electrocutation can occur without direct contact.

SAFETY PRECAUTIONS (CONT'D)
Maintenance Safety

- Review Operation, Maintenance & Parts Manual and all safety items before working with, maintaining or operating applicator.
- Before servicing, adjusting, repairing or replacing:
 - Lower machine to ground
 - Place all controls in neutral
 - Stop engine
 - Set park brake
 - Remove ignition key
 - Wait for all moving parts to stop
- Follow good shop practices:
 - Keep service area clean and dry.
 - Be sure electrical outlets and tools are properly grounded.
 - Use adequate light for job at hand.
- Before applying pressure to a hydraulic system make sure all components are tight, hoses and couplings are in good condition.
- Relieve pressure from hydraulic circuit before servicing or disconnecting from tractor.
- Keep hands, feet, clothing and hair away from all moving and/or rotating parts.
- Clear area of bystanders, especially children, when carrying out any maintenance and repairs or making any adjustments or filling.
- Place stands or blocks under frame before working beneath machine or when changing tires.
- Be sure all guards are in place and secured when maintenance work is completed.
- Use only tools, jacks and hoists of sufficient capacity for the equipment weight and size and procedure.

FIRE PREVENTION

Maintenance

The equipment may have components that are at high temperatures under normal operating conditions. The primary source of high temperatures is the engine and exhaust system. The electrical system, if damaged or incorrectly maintained, can be a source of arcs or sparks.

Flammable debris must be removed regularly. If flammable debris is allowed to accumulate, it can cause a fire hazard.

All fuels, most lubricants and some coolant mixtures are flammable. Flammable fluids that are leaking or spilled onto hot surfaces or onto electrical components can cause a fire.

Electrical

Check all electrical wiring and connections for damage. Keep the battery terminals clean and tight. Repair or replace any damaged part or wires that are loose or frayed.

FIRE PREVENTION (CONT'D)

Hydraulic System

- Always place all tractor hydraulic controls in neutral before dismounting.
- Make sure that all components in hydraulic system are kept in good condition and are clean.
- Replace any worn, cut, flattened or crimped hoses.
- Do not attempt any makeshift repairs to hydraulic lines, fittings or hoses by using tape, clamps or cements. The hydraulic system operates under extremely high-pressure. Inappropriate repairs will fail suddenly and create a hazardous and unsafe condition.
- Pressurized fluids can penetrate the skin. Hydraulic hoses can fail from age, damage and exposure. Do not search for hydraulic leaks without body and face protection. A tiny, almost invisible leak can penetrate the skin, thereby requiring immediate medical attention. Use wood or cardboard to detect hydraulic leaks, *never* use your hands.
- If injured by a concentrated high-pressure stream of hydraulic fluid, seek medical attention immediately. Serious infection or toxic reaction can develop from hydraulic fluid piercing skin surface.
- Before applying pressure to system; verify all components are tight, and that hoses and couplings are in good condition.

Welding And Grinding

Always clean the equipment, disconnect the battery, and disconnect the wiring before welding. Cover rubber hoses, battery and all other flammable parts. Keep a fire extinguisher near the equipment when welding.

Have good ventilation when grinding or welding painted parts. Wear dust mask when grinding painted parts. Toxic dust or gas can be produced.

Dust generated from repairing nonmetallic parts can be flammable or explosive. Repair such components in a well ventilated area away from open flames or sparks.

Fire Extinguishers

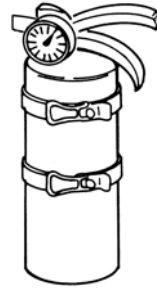

Know where fire extinguishers and first aid kits are located and how to use them. Inspect the fire extinguisher and service the fire extinguisher regularly. Obey the recommendations on the instructions plate.

SAFETY IDENTIFICATION

Decals

Hitch Decal Locations

Figure 3

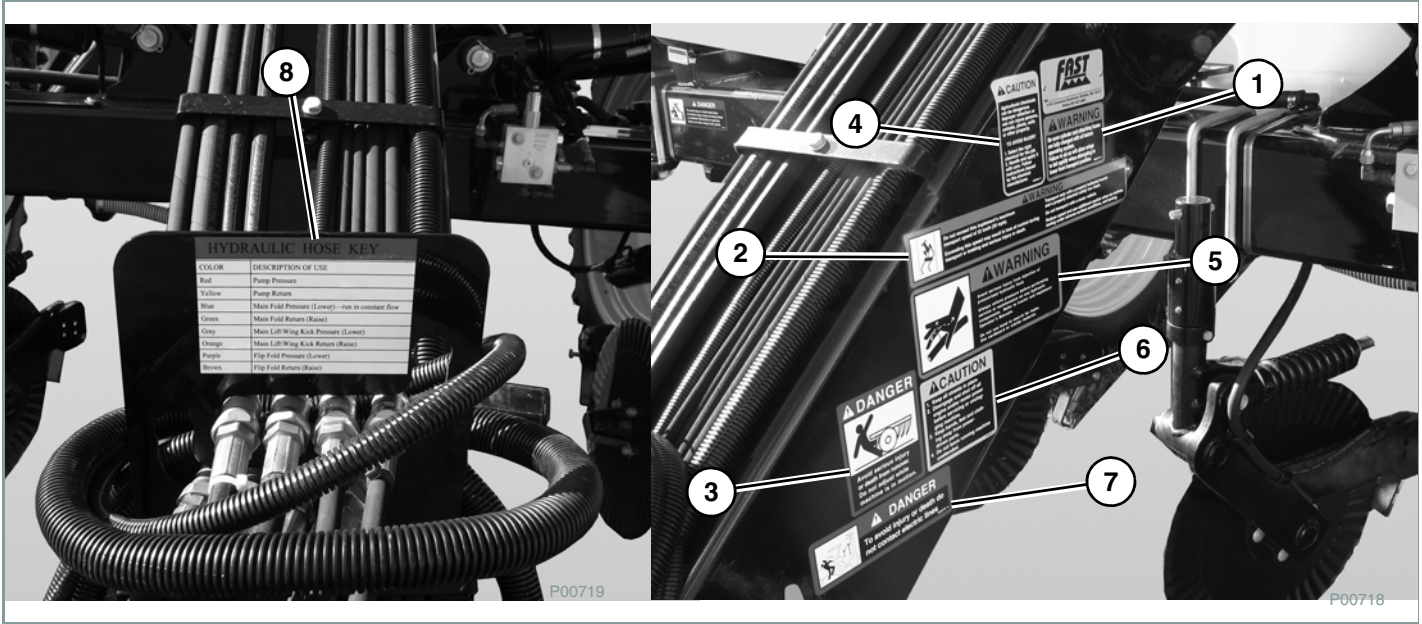

Wing Decal Locations

Figure 4

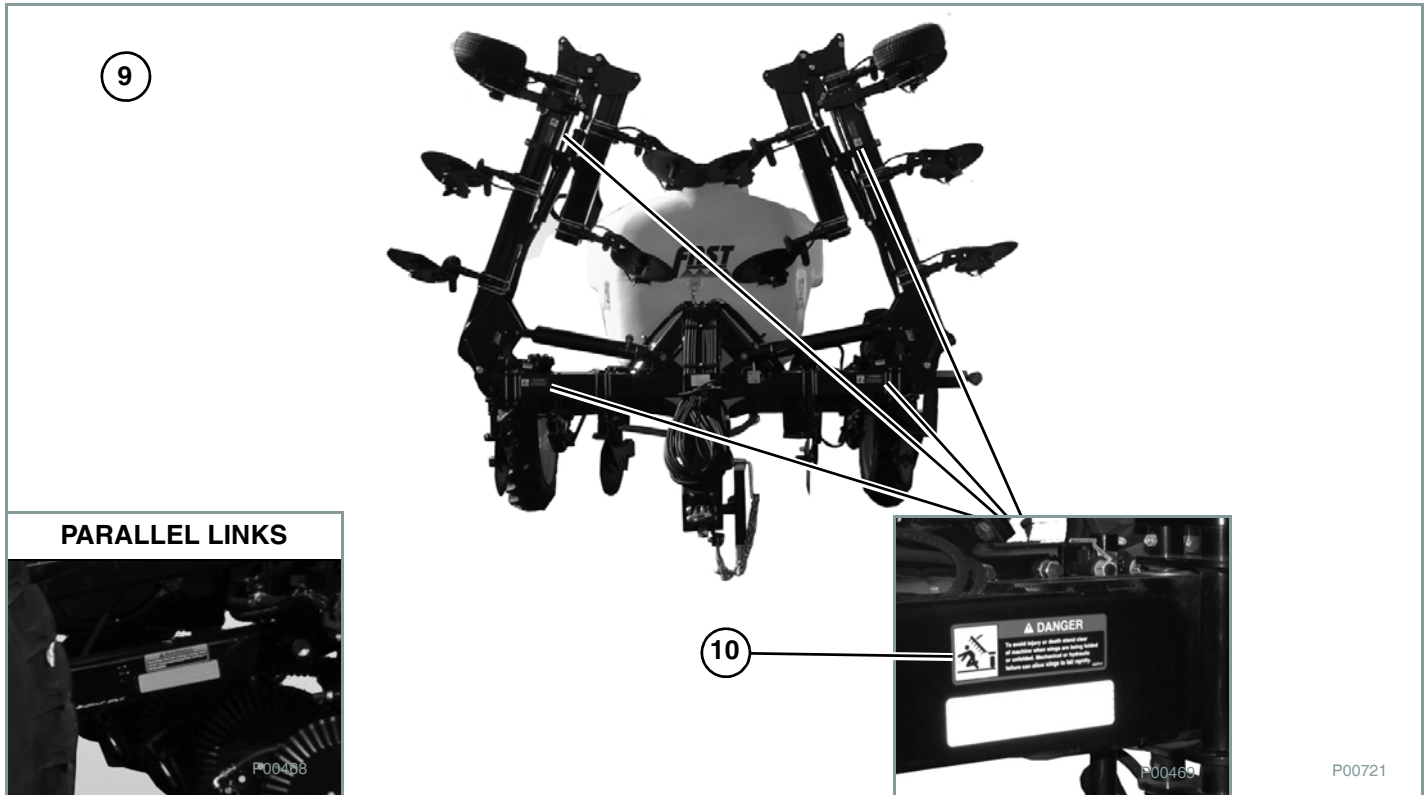

SAFETY IDENTIFICATION (CONT'D)

Decals (Cont'd)

Rear Frame Decal Locations

Figure 5

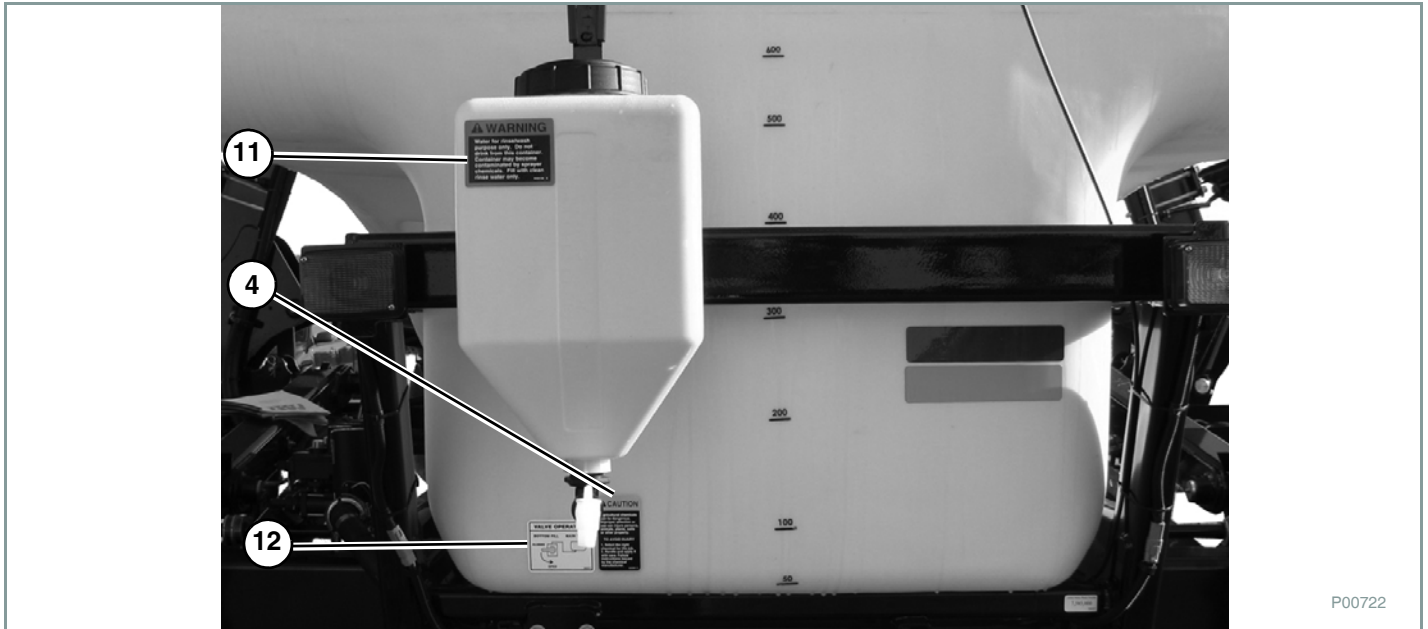

Rear Frame Decal Locations

Figure 6

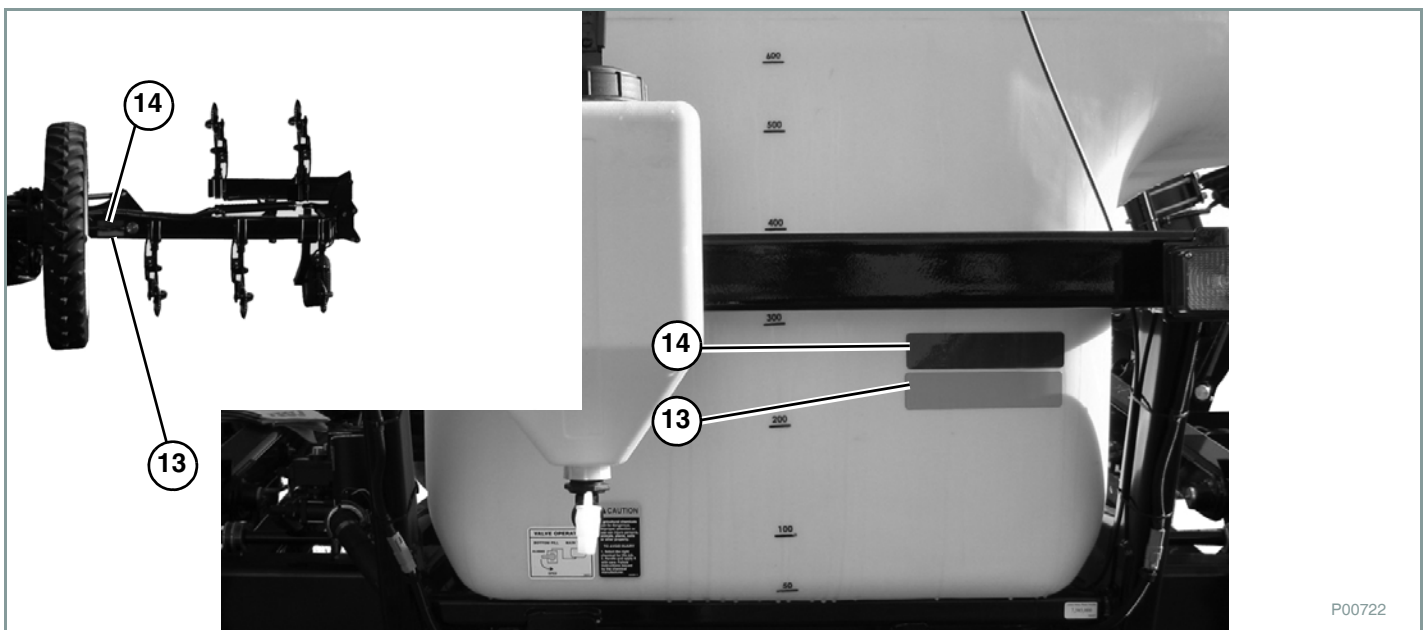

SAFETY IDENTIFICATION (CONT'D)

Decals (Cont'd)

Safety signs are used to alert the equipment operator or maintenance person to hazards and information that may be encountered in the use and maintenance of the equipment. The location and description of the safety signs are detailed in this section. Please become familiar with all safety signs installed on the machine / equipment.

A safety sign may contain more than one hazard panel and more than one avoidance panel.

NOTE: See the numbered (See Decals on Page 14 and 15 for the location of each correspondingly numbered decal.

1. Hydraulic Hazard (800100)

This safety sign is located six places on the liquid fertilizer applicator (two places on the hitch and four places on the wings).

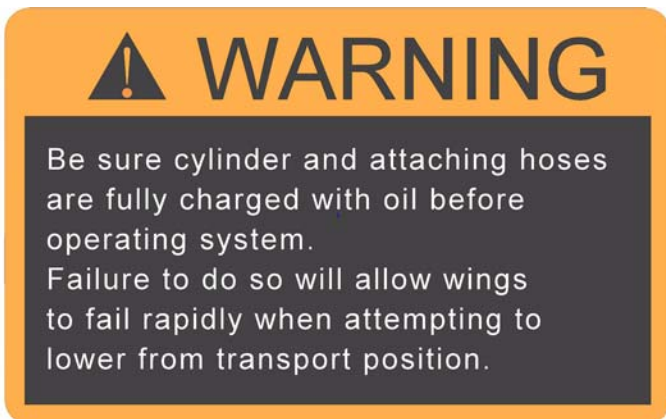

2. Travel Hazard (800104)

This safety sign is located one place on the liquid fertilizer applicator hitch.



3. Adjustment Hazard (800103)

This safety sign is located one place on the liquid fertilizer applicator hitch.



4. Chemical Hazard (800101)

This safety sign is located one place on the liquid fertilizer applicator hitch.

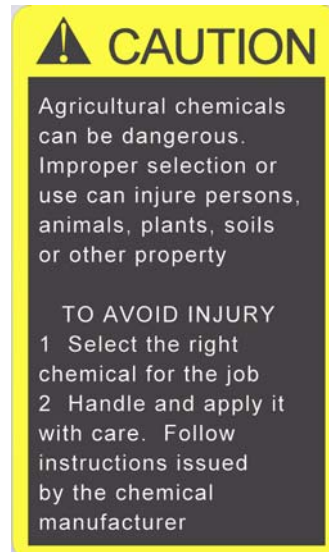

SAFETY IDENTIFICATION (CONT'D)

Decals (Cont'd)

5. Hydraulic Hazard (800098)

This safety sign is located one place on the liquid fertilizer applicator hitch.



6. Chemical Hazard (800100)

This safety sign is located one place on the liquid fertilizer applicator hitch.



7. Electrical Hazard (800112)

This safety sign is located one place on the liquid fertilizer applicator hitch.

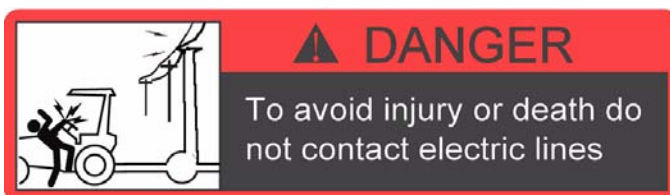

8. Hydraulic Hose Identification (800087)

This safety sign is located one place on the liquid fertilizer applicator hitch.

HYDRAULIC HOSE KEY	
COLOR	DESCRIPTION OF USE
Red	Pump Pressure
Yellow	Pump Return
Grey	Main Lift \ Wing Kick Pressure (Raise)
Orange	Main Lift \ Wing Kick Return (Lower) - Run in Constant Flow
Purple	Hydraulic Block Pressure
Brown	Hydraulic Block Return

9. Crush Hazard (800105)

This safety sign is located one place on the liquid fertilizer applicator wings.

SAFETY IDENTIFICATION (CONT'D)

Decals (Cont'd)

10. Crush Hazard (800106)

This safety sign is located one place on the liquid fertilizer applicator wings.

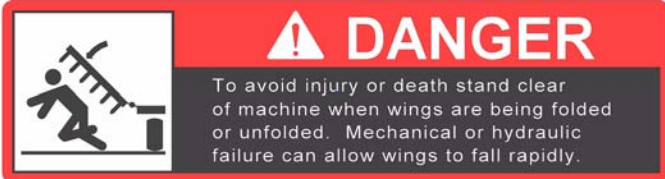

11. Rinse Water Hazard (800108)

This safety sign is located one place on the liquid fertilizer fresh water tank.

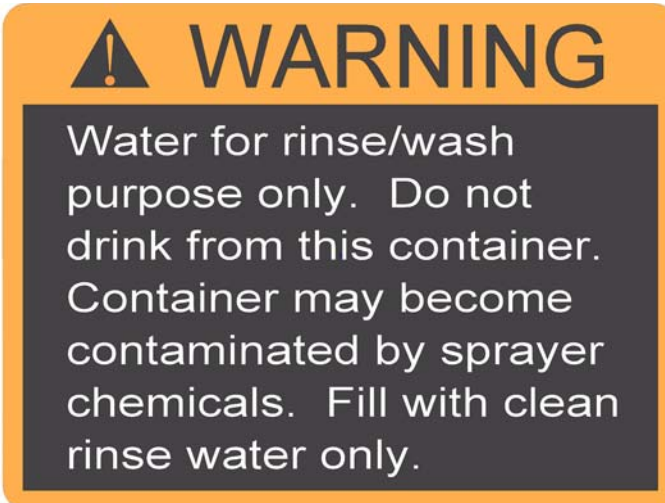

12. Operating (800017)

This safety sign is located one place on the liquid fertilizer applicator hitch.

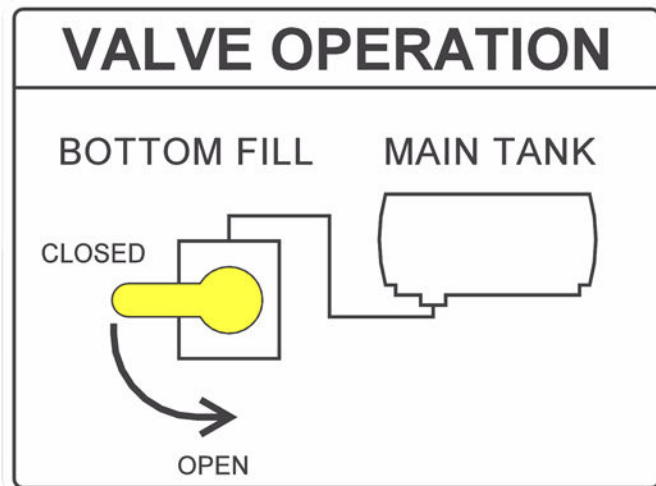

13. Reflector (800110)

This safety sign is located two places on the liquid fertilizer applicator hitch.



14. Reflector (800111)

This safety sign is located two places on the liquid fertilizer applicator hitch.





GENERAL INFORMATION AND OPERATING INSTRUCTIONS

GENERAL INFORMATION AND OPERATING INSTRUCTION SAFETY PRECAUTIONS . . .21

PURPOSE OF EQUIPMENT24

GENERAL DESCRIPTION24

MAJOR COMPONENTS25

EQUIPMENT SPECIFICATIONS26

 Dimensions 11 Coulters With 30 In. (762 mm) Spacing26

 Performance 11 Coulters With 30 In. (762 mm) Spacing27

 Dimensions 13 Coulters With 30 In. (762 mm) Spacing28

 Performance 13 Coulters With 30 In. (762 mm) Spacing29

 Dimensions 15 Coulters With 30 In. (762 mm) Spacing30

 Performance 15 Coulters With 30 In. (762 mm) Spacing31

PRE-OPERATION SETUP32

 Initial Operation Checklist32

 Pre-Operation Checklist33

 Tractor Requirements34

 Entering And Exiting Operator’s Position35

 Connecting The Fertilizer Applicator To The Tractor35

 Connecting Hydraulic Hoses And Electrical Connections38

 Controls Description39

 Leveling The Liquid Fertilizer Applicator40

 Unfold And Fold Toolbar41

 Coulters Depth/Tool Bar Raise/Lower Adjustments45

 System Screen48

FIELD OPERATION48

POST-OPERATION DISCONNECTION53

TRANSPORTATION54

STORAGE INSTRUCTIONS55

 Storage55

 Re-Commissioning55



GENERAL INFORMATION AND OPERATING INSTRUCTION SAFETY PRECAUTIONS

DANGER

ELECTROCUTION HAZARD

To prevent serious injury or death from electrocution:

- Be aware of overhead powerlines.
- Keep away from powerlines when transporting or folding or unfolding wings.
- Electrocution can occur without direct contact.

D-2015-004

DANGER

CRUSH HAZARD

To avoid serious injury or death, keep everyone clear of machine when folding or extending wings.

D-2015-005

DANGER



CHEMICAL HAZARD

To prevent serious injury or death:

WEAR PERSONAL PROTECTIVE EQUIPMENT

- Do not allow chemical or solution to touch skin.
- Some chemicals can be absorbed through the skin.
- Wear rubber gloves and protective gear at all times.

DON'T BREATHE VAPOR

- Avoid chemical splash and vapor. Keep others away.
- Do not breathe vapor.
- Wear proper respirator when working with chemicals.
- Chemicals can be toxic.

DON'T INGEST CHEMICAL

- If in eyes or mouth, read manufacturer's instructions and follow them exactly.
- Seek immediate medical attention.
- Before working with chemicals, know the poison control phone number for your location.

D-2015-006

WARNING



CRUSHING HAZARD

- Before moving the tow vehicle / equipment, look in all directions and make sure no bystanders are in the work area.
- Do not allow anyone between the tow vehicle and the equipment when backing up to the equipment for connecting.

W-2014-005

 **WARNING**



CRUSHING HAZARD

Keep fingers and hands out of pinch points when connecting and disconnecting equipment.

W-2014-002

 **WARNING**

AVOID INJURY OR DEATH

Use of an unapproved hitch or tow vehicle can result in loss of control, leading to serious injury or death. Tow vehicle and hitch must have the rated capacity to tow this equipment.

W-2014-004

 **WARNING**

Verify that the equipment is securely fastened to the tow vehicle before moving the tow vehicle and equipment.

W-2014-006

 **WARNING**

AVOID INJURY OR DEATH

Pay attention to surrounding areas to prevent being crushed between two pieces of equipment.

W-2013-020

 **WARNING**

AVOID INJURY OR DEATH

Install and secure all guards and shields before starting or operating.

W-2015-019

 **WARNING**

AVOID INJURY OR DEATH

Do not allow riders on the applicator or tractor during operation or transporting.

W-2015-021

 **WARNING**

AVOID INJURY OR DEATH

Clear area of all bystanders, especially children, before starting or filling with chemical or fertilizer.

W-2015-022

 **WARNING**

AVOID INJURY OR DEATH

Do not breathe, touch or ingest chemicals or fertilizer. Always wear protective clothing and follow safe handling procedures.

W-2015-024

GENERAL INFORMATION AND OPERATING INSTRUCTION SAFETY PRECAUTIONS (CONT'D)

 **WARNING**

AVOID INJURY OR DEATH

Read chemical or fertilizer manufacturers warnings, instructions and procedures before starting and follow them exactly.

W-2015-023

 **WARNING**

AVOID INJURY OR DEATH

Stay away from wings when folding or extending wings. Keep others away.

W-2015-025

 **WARNING**

AVOID INJURY OR DEATH

Do not exceed a safe travel speed.

W-2015-026

 **WARNING**

AVOID INJURY OR DEATH

Stay away from overhead power lines when folding or extending the wings and during transport.

W-2015-027

 **WARNING**

AVOID SERIOUS INJURY OR DEATH

Do not spill chemicals on skin or clothing. If chemicals are spilled, remove contaminated clothing immediately and wash skin (and clothing) thoroughly with soap and water. Wash hands and face with soap and water and change clothing after spraying.

W-2015-034

 **WARNING**

AVOID SERIOUS INJURY OR DEATH

Always read the label before using chemicals. Follow the instructions from the chemical manufacturer on how to select, use and handle each chemical. Note protection information each time before opening the container.

W-2015-035

IMPORTANT

Clean reflectors, SMV emblem and lights before transporting.

I-2015-014

IMPORTANT

Attach securely to towing unit using a hardened pin with a retainer and a safety chain.

I-2015-015

IMPORTANT

Use hazard flasher on tractor when transporting.

I-2015-016

IMPORTANT

Verify main tank is empty before transporting on road.

I-2015-017

PURPOSE OF EQUIPMENT

The FAST AG Solutions Liquid Fertilizer Applicator is used to safely provide a means for liquid fertilizer to be properly applied to a field. The FAST AG Solutions Liquid Fertilizer Applicator has a hydraulic powered pump to send liquid chemicals or fertilizer to the control section (Flow Meter and MCV (Motorized Control Valve)). From the control section, product flows through the ball valve to the distribution lines on the toolbar. Coulters open the soil to receive the liquid. Nozzles/Knives mounted to the toolbar spray/inject the fluid into the soil.

GENERAL DESCRIPTION

For more information on:

- Major Components (See Page 25).
- Dimensions (See Page 26).
- Performance (See Page 31).

MAJOR COMPONENTS

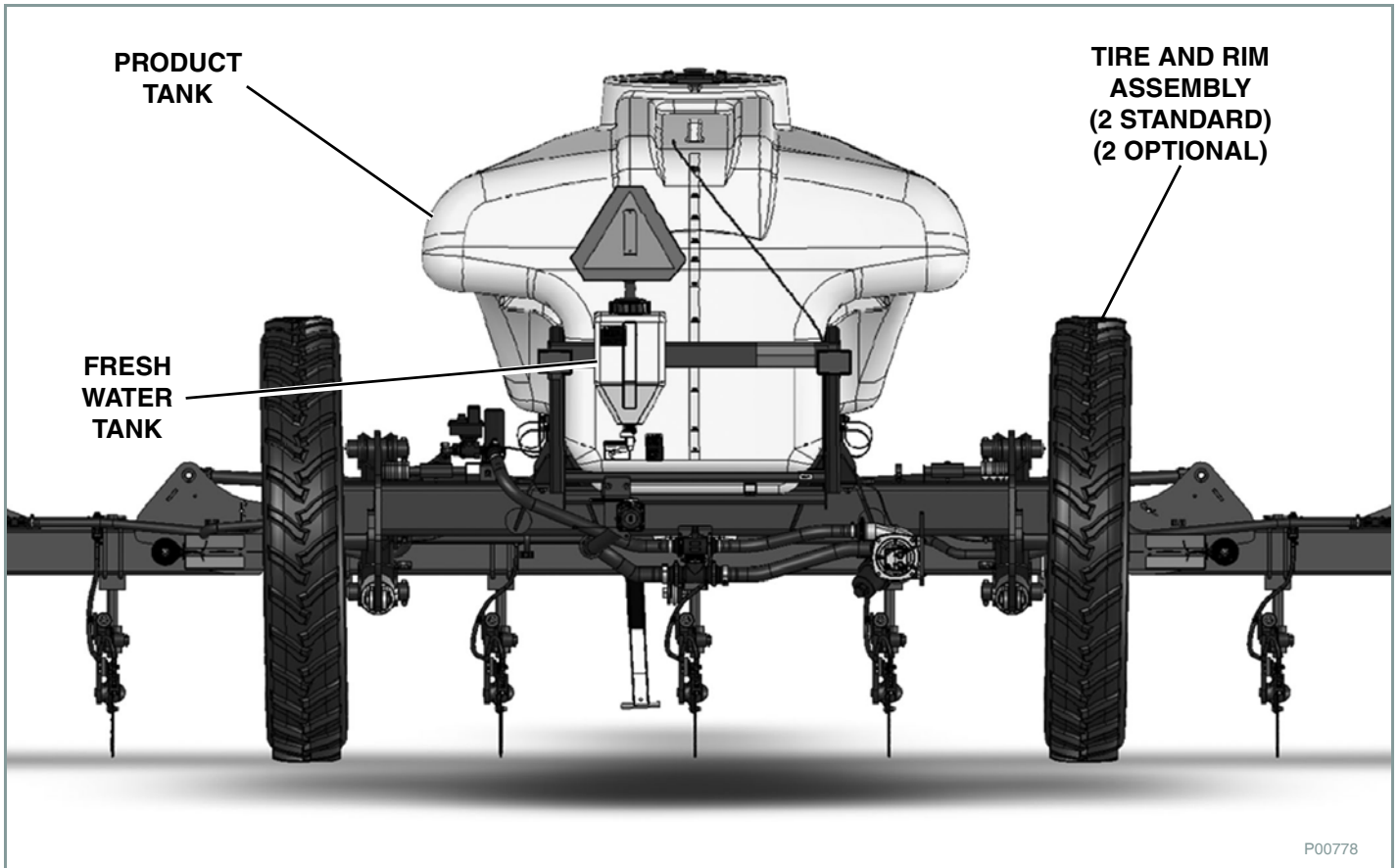
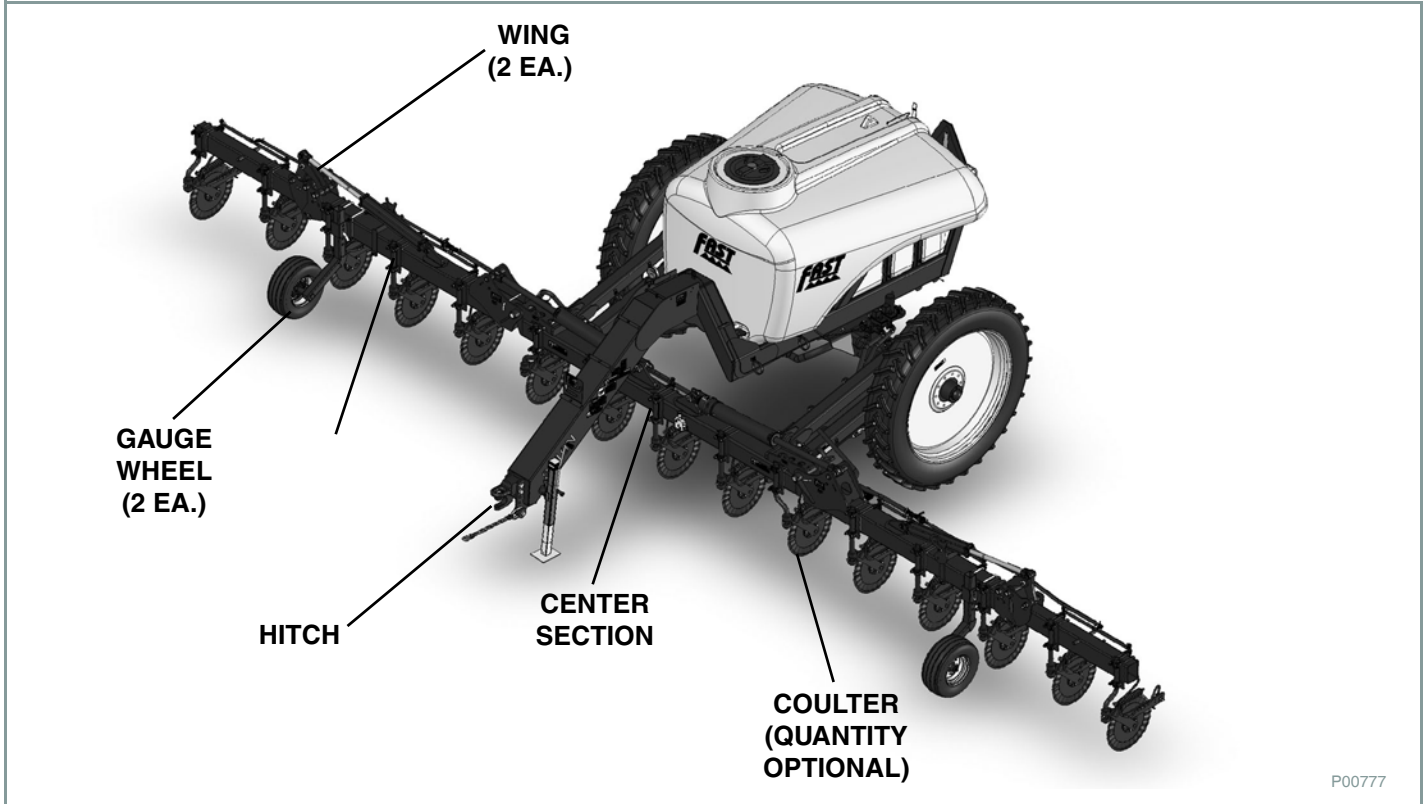

EQUIPMENT SPECIFICATIONS

Dimensions 11 Coulters With 30 In. (762 mm) Spacing

- Where applicable, specifications conform to **SAE and ISO** standards and are subject to change without notice.

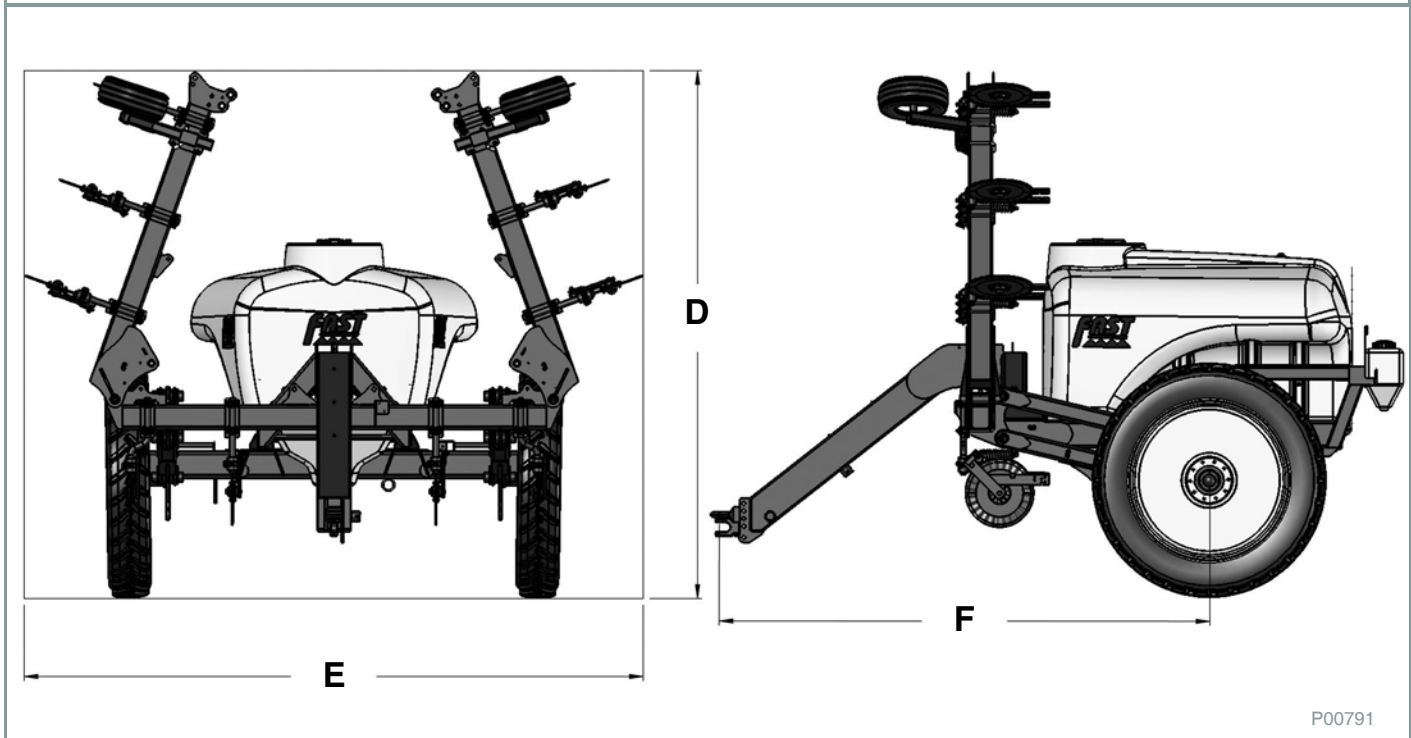
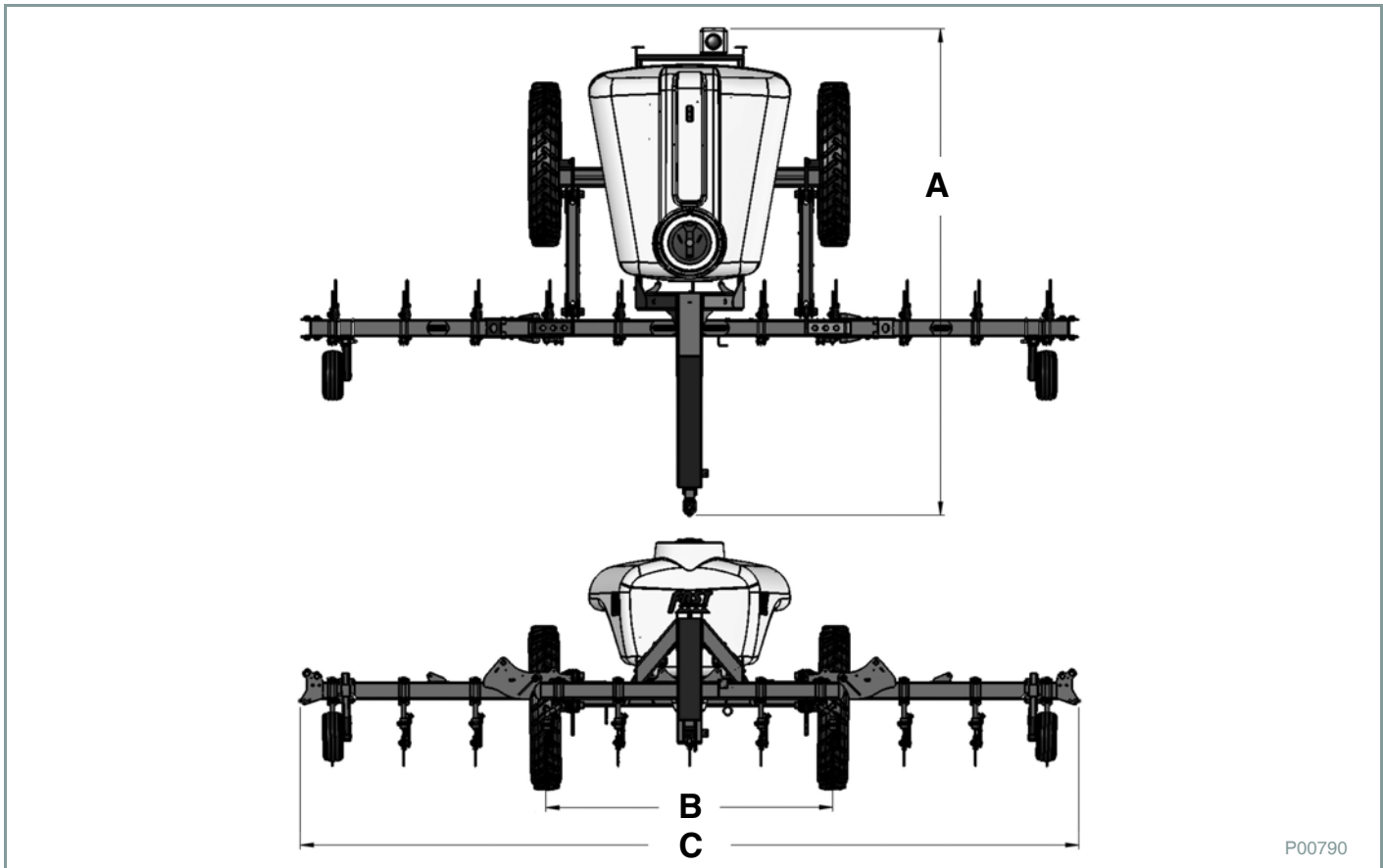



EQUIPMENT SPECIFICATIONS (CONT'D)

Dimensions 11 Coulters With 30 In. (762 mm) Spacing (Cont'd)

DESCRIPTION	MODEL 8010N-8013N
Length (A)	17 ft. 0 in. (5182 mm)
Width, Tires (B)	120 in. (3048 mm)
Width, Wings Unfolded (C)	26 ft. 9 in. (17120 mm)
Height, Wings Folded (D)	12 ft. 11 in. (3937 mm)
Width, Wings Folded (E)	15 ft. 2 in. (4623 mm)
Length, Hitch To Center Of Tire (F)	12 ft. 0 in. (3658 mm)

Performance 11 Coulters With 30 In. (762 mm) Spacing

DESCRIPTION	MODEL 8010N-8013N
Tractor Horse Power Requirement	30 ft (76.2 cm) 110 hp
Weight	7000 lb. (3175.15 kg)
Capacity	1050 gal (3975 l) or 1350 gal (5110 l)
Tow Speed (Maximum)	* 20 mph (32 kmh)
	** 10 mph (16 kmh)
	*** DO NOT TOW

* - Weight of fully equipped liquid fertilizer applicator equal to or less than the weight of towing machine.

** - Weight of fully equipped liquid fertilizer applicator is two times or less than the weight of towing machine.

*** - Weight of fully equipped liquid fertilizer applicator more than two times the weight of towing machine.

IMPORTANT	<p>PREVENT EQUIPMENT DAMAGE.</p> <p>Verify main tank is empty before transporting on road.</p>	I-2015-025
------------------	--	------------

EQUIPMENT SPECIFICATIONS (CONT'D)

Dimensions 13 Coulters With 30 In. (762 mm) Spacing

- Where applicable, specifications conform to **SAE and ISO** standards and are subject to change without notice.

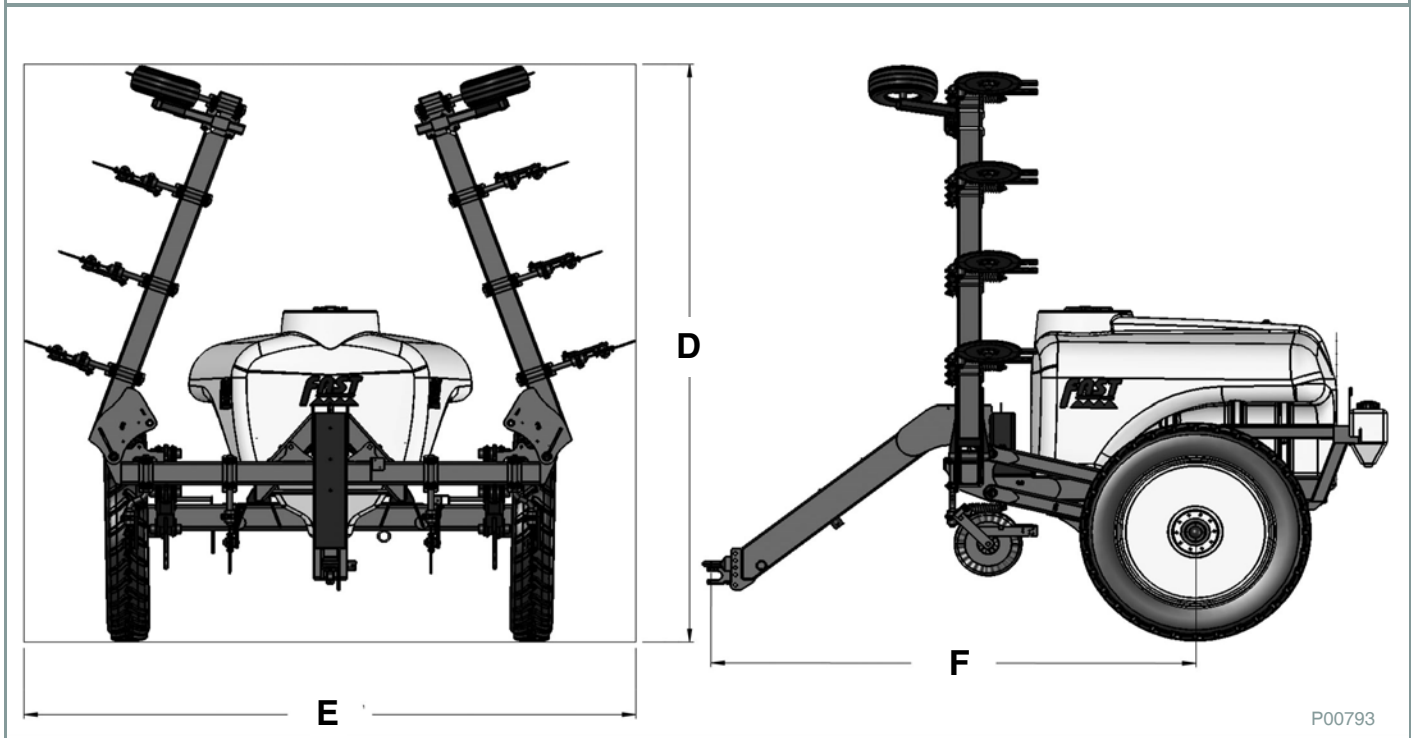
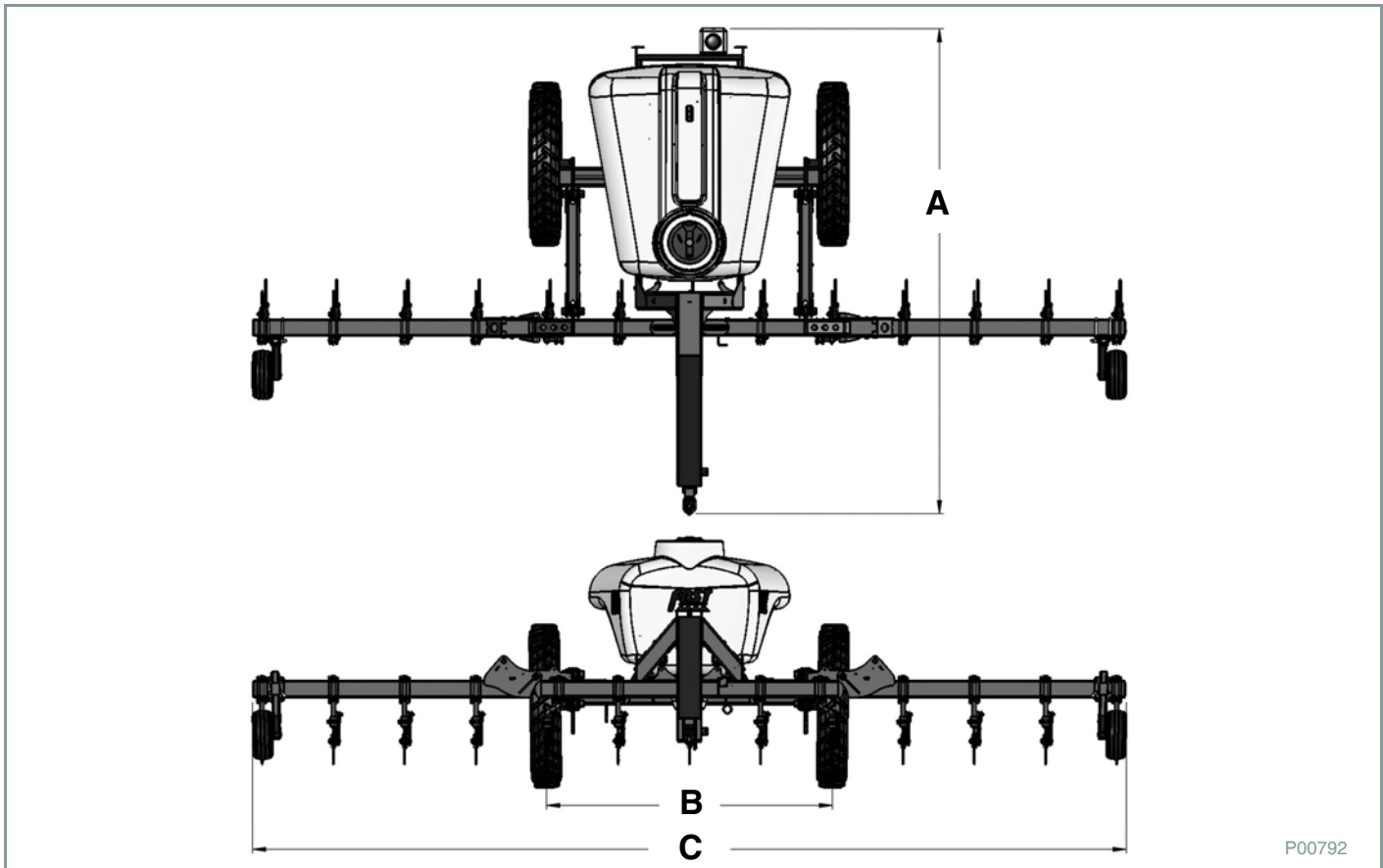



EQUIPMENT SPECIFICATIONS (CONT'D)

Dimensions 13 Coulters With 30 In. (762 mm) Spacing (Cont'd)

DESCRIPTION	MODEL 8010N-8013N
Length (A)	17 ft. 0 in. (5182 mm)
Width, Tires (B)	120 in. (3048 mm)
Width, Wings Unfolded (C)	30 ft. 8 in. (9347 mm)
Height, Wings Folded (D)	15 ft. 2 in. (4623 mm)
Width, Wings Folded (E)	15 ft. 2 in. (4623 mm)
Length, Hitch To Center Of Tire (F)	12 ft. 0 in. (3658 mm)
Weight	7250 lb. (3288.54 kg)

Performance 13 Coulters With 30 In. (762 mm) Spacing

DESCRIPTION	MODEL 8010N-8013N
Tractor Horse Power Requirement	30 ft (76.2 cm) 130 hp
Weight	7250 lb. (3288.5 kg)
Capacity	1050 gal (3975 l) or 1350 gal (5110 l)
Tow Speed (Maximum)	* 20 mph (32 kmh)
	** 10 mph (16 kmh)
	*** DO NOT TOW

* - Weight of fully equipped liquid fertilizer applicator equal to or less than the weight of towing machine.

** - Weight of fully equipped liquid fertilizer applicator is two times or less than the weight of towing machine.

*** - Weight of fully equipped liquid fertilizer applicator more than two times the weight of towing machine.

IMPORTANT	<p>PREVENT EQUIPMENT DAMAGE.</p> <p>Verify main tank is empty before transporting on road.</p>
------------------	--

I-2015-025

EQUIPMENT SPECIFICATIONS (CONT'D)

Dimensions 15 Coulters With 30 In. (762 mm) Spacing

- Where applicable, specifications conform to **SAE and ISO** standards and are subject to change without notice.

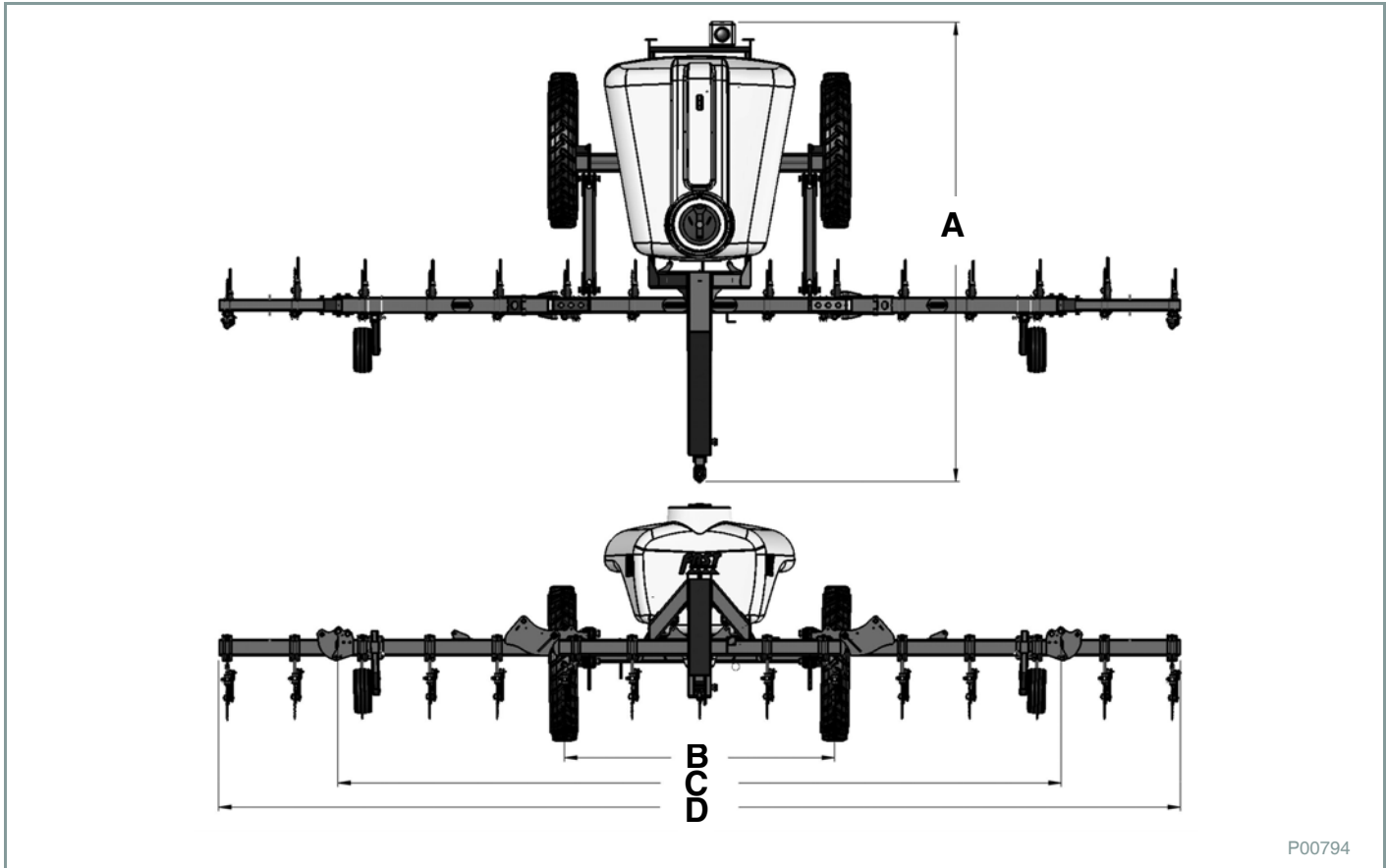

P00794

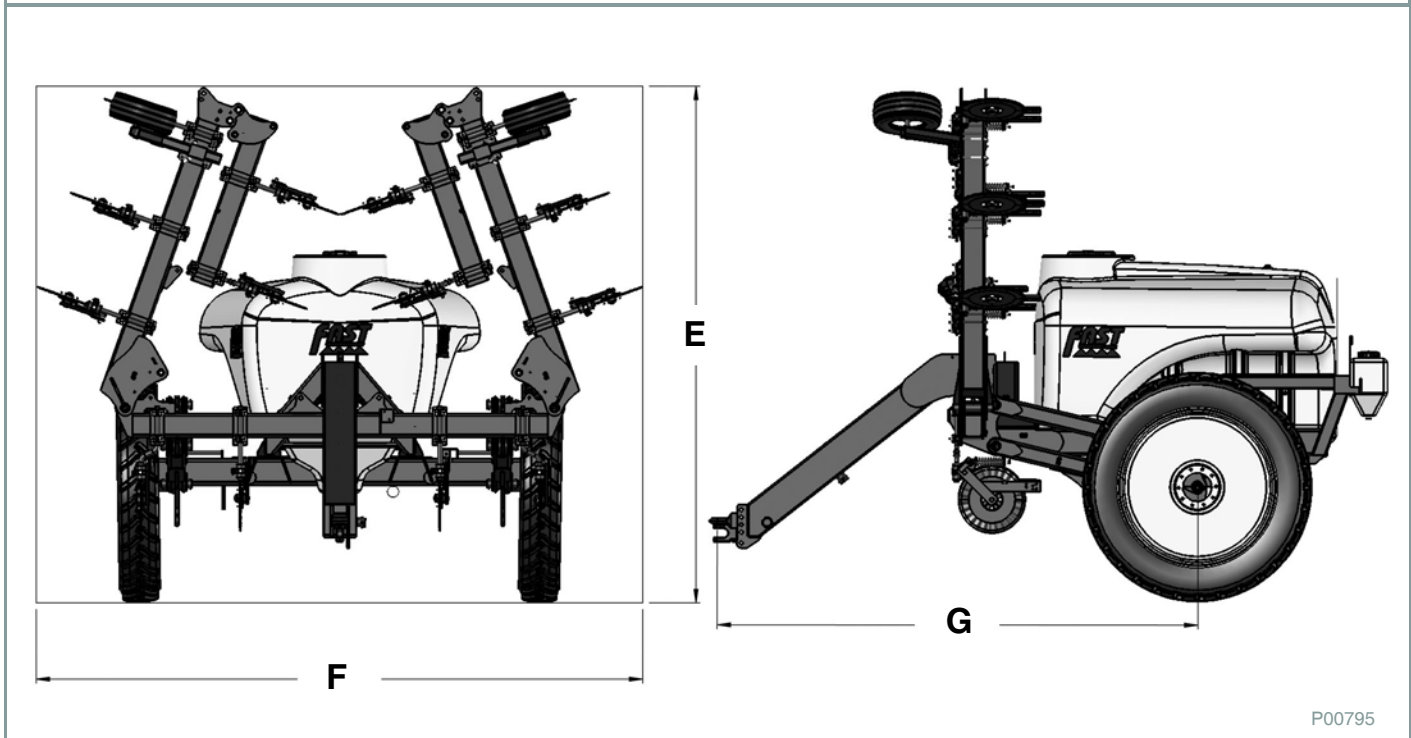

P00795



EQUIPMENT SPECIFICATIONS (CONT'D)

Dimensions 15 Coulters With 30 In. (762 mm) Spacing (Cont'd)

DESCRIPTION	MODEL 8010N-8013N
Length (A)	17 ft. 0 in. (5182 mm)
Width, Tires (B)	120 in. (3048 mm)
Width, Inner Wings Unfolded (C)	26 ft. 9 in. (17120 mm)
Width, Outer Wings Unfolded (D)	35 ft. 7 in. (10846 mm)
Height, Wings Folded (E)	12 ft. 11 in. (3937 mm)
Width, Wings Folded (F)	15 ft. 2 in. (4623 mm)
Length, Hitch To Center Of Tire (G)	12 ft. 0 in. (3658 mm)

Performance 15 Coulters With 30 In. (762 mm) Spacing

DESCRIPTION	MODEL 8010N-8013N
Tractor Horse Power Requirement	40 ft (101.6 cm) 150 hp
Weight	7500 lb. (3401.9 kg)
Capacity	1050 gal (3975 l) or 1350 gal (5110 l)
Tow Speed (Maximum)	* 20 mph (32 kmh)
	** 10 mph (16 kmh)
	*** DO NOT TOW

* - Weight of fully equipped liquid fertilizer applicator equal to or less than the weight of towing machine.

** - Weight of fully equipped liquid fertilizer applicator is two times or less than the weight of towing machine.

*** - Weight of fully equipped liquid fertilizer applicator more than two times the weight of towing machine.

IMPORTANT	<p>PREVENT EQUIPMENT DAMAGE.</p> <p>Verify main tank is empty before transporting on road.</p>
------------------	---

I-2015-025

PRE-OPERATION SETUP

Initial Operation Checklist

NOTE: Perform the following steps when using a new applicator.

After First Hour Of Operation

- Torque all wheel lug nuts.
8010 wheel lug torque is 140-170 ft-lb (190-230 N•m).
8013N wheel lug torque is 265 ft-lb (359.30 N•m).
- Tighten all other fasteners and hardware to required torque.
- Check that no chemical or hydraulic lines are being pinched or crimped. Re-route as required.
- Check that all coulters, nozzles and placement components are clean and working properly. Clean as required.
- Check that metering pump is functioning properly. Adjust as required.
- Lubricate all grease fittings. (See PREVENTATIVE MAINTENANCE on Page 59.)

After Five Hours Of Operation

- Torque all wheel lug nuts.
8010 wheel lug torque is 140-170 ft-lb (190-230 N•m).
8013N wheel lug torque is 265 ft-lb (359.30 N•m).

After 10 hours of operation

- Torque all wheel lug nuts.
8010 wheel lug torque is 140-170 ft-lb (190-230 N•m).
8013N wheel lug torque is 265 ft-lb (359.30 N•m).
- Tighten all fasteners and hardware to required torque.
- Check chemical and hydraulic line routing.
- Check that all placement components are clean and working properly.

After 50 hours of operation

- Torque all wheel lug nuts.
8010 wheel lug torque is 140-170 ft-lb (190-230 N•m).
8013N wheel lug torque is 265 ft-lb (359.30 N•m).
- Perform normal servicing and maintenance. (See PREVENTATIVE MAINTENANCE on Page 59.)



PRE-OPERATION SETUP (CONT'D)

Pre-Operation Checklist

NOTE: Efficient and safe operation of the Fast Distributing Liquid Fertilizer Applicator requires that each operator reads and understands operating procedures and all related safety precautions outlined in this section. A pre-operational checklist is provided for the operator. It is important for both personal safety and maintaining good mechanical condition of the applicator that this checklist be followed.

Before operating applicator, check the following items:

- Use only a tractor of adequate power and weight to operate applicator. (See Performance 15 Coulters With 30 In. (762 mm) Spacing on Page 31.)
- Lubricate all grease fittings. (See PREVENTATIVE MAINTENANCE on Page 59.)
- Be sure that machine is properly attached to tractor. Be sure that a mechanical retainer is installed through drawbar pin and safety chain is installed.
- Inspect all hydraulic lines, hoses, fittings and couplers for tightness.
- Check tires and verify they are inflated to specified pressure.
- Calibrate applicator if at start of season or a new applicator rate is being used.
- Check condition and routing of all fluid hoses and lines. Be sure that all lines are routed in large arcs. Replace any that are damaged. Re-route those that are rubbing, pinched or crimped.
- Check placement components. Remove and replace any that are worn.
- Remove all entangled material.
- Raise toolbar slightly. Check that there is liquid coming out of each nozzle. Unplug or connect lines as required. Replace any nozzles that are plugged.

PRE-OPERATION SETUP (CONT'D)

Tractor Requirements

NOTE: To insure the safe and reliable operation of the applicator, it is necessary to use a tractor with appropriate specifications.

Confirm the following requirements are met:

Tractor Horsepower: Refer to “Performance 15 Coulters With 30 In. (762 mm) Spacing” on page 31.

NOTE: Although recommended tractor horsepower is not required to pull machine, it does provide required strength on drawbar as hitch is very heavy. This will also insure that the unit has the required stability and control in hilly terrain and during transport.

Front End Weights: It is also recommended that each tractor be equipped with full suitcase weights on front of tractor. This will provide the required weight on front for turning and extra traction if equipped with front wheel assist.

Hydraulic System: Tractor hydraulic system must have a flow of 8 gpm (30 lpm) at 2950 psi (20340 kPa) to operate lift cylinders and drive motor.

NOTE: Either closed-centered or open-centered systems can be used.

NOTE: Contact FAST AG Solutions for optional flow control for use with high flow open-center system.

Remote Outlets: Three remote outlets are required for 30 ft. (9144 mm):

- Chemical/fertilizer pump drive motor.
Set as required.
- Main fold pressure.
Set to main flow.
- Main lift/wing kick cylinders.
Set to 5 gpm (19 lpm).
- A fourth is required for:
Flip fold cylinders. (Only on 15 coulter bars.)
Set to 5 gpm (19 lpm).

IMPORTANT

TO PREVENT DAMAGE TO LINKAGES AND CYLINDERS

Always place tractor hydraulic control lever in detent to provide a constant flow of oil to the down pressure system.

If operating in very soft conditions and down pressure is not wanted, place lever in "float" to allow cylinder to extend or retract as necessary by ground conditions.

I-2016-004

NOTE: Always place tractor's hydraulic control lever in detent to provide a constant flow of oil to pump drive motor. (See the tractor's Operation & Maintenance manual.)

REGULATING HYDRAULIC FLOW TO THE SPRAYER PUMP

Locate your tractor model and follow the appropriate setup instructions.

WARNING: FAILURE TO REGULATE OIL FLOW WILL CAUSE MOTOR FAILURE.

WARNING: NOT SUITABLE FOR PUMPING FLAMMABLE LIQUIDS.

LOAD SENSING CLOSED CENTER SYSTEM (LS CLOSED)

Regulate oil flow with tractor's **FLOW CONTROL** and **FLOW LIMITER**.

(Do not use restrictor orifice.)

Setup Instructions:

1. (Optional) Remove adapter and install flow limiter in motor inlet port (marked **I**).
2. Close motor needle valve: loosen jam nut, screw needle valve clockwise until seated, and lock jam nut. (factory setting)
3. Shut off sprayer boom and agitation valves.
4. Adjust tractor flow control to minimum flow setting (turtle).
5. Move hydraulic lever to "Lower/Retract" position to start pump.
6. Adjust tractor flow control until sprayer shut-off pressure is below maximum shown in table on page 3.

Note: If the flow limiter stops oil flow to the motor:

- 6a) Move hydraulic lever to "Float" or "Neutral" to remove oil pressure from the flow limiter.
 - 6b) Adjust tractor flow control to a lower flow position.
 - 6c) Repeat steps 5 and 6.
7. Open the sprayer agitation valve to get desired spraying pressure.

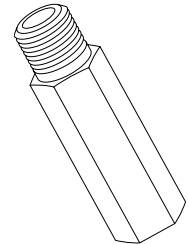

FLOW LIMITER

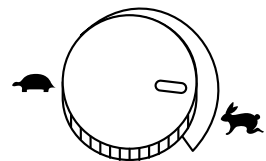

FLOW CONTROL

PRESSURE COMPENSATING CLOSED CENTER SYSTEM (PC CLOSED)

Regulate oil flow by using a **RESTRICTOR ORIFICE**.

(Do not use flow limiter.)

Setup Instructions:

1. Install restrictor orifice insert inside the adapter/restrictor body in the motor inlet port (marked **I**).
2. Close motor needle valve: loosen jam nut, screw needle valve clockwise until seated, and lock jam nut. (factory setting)
3. Set "Rabbit/Turtle" flow control to "Turtle".
4. Move hydraulic lever to the "Lower/Retract" position to start pump.
5. Adjust "Rabbit /Turtle" flow control and sprayer agitation valve to get desired spraying pressure.

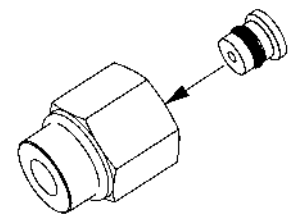

RESTRICTOR
ORIFICE

OPEN CENTER SYSTEM (OPEN)

Select motor size closest to tractor's hydraulic system capacity. Regulate oil flow with motor **NEEDLE VALVE**.

(Do not use restrictor orifice or flow limiter.)

Setup Instructions:

1. Shut off sprayer boom and agitation valves.
2. Loosen jam nut on motor and back out needle valve 3 or 4 turns counter clockwise.
3. Set tractor throttle to sprayer operating speed.
4. Move hydraulic lever to "Lower/Retract" position to start pump.
5. Screw needle valve clockwise until sprayer shut-off pressure is below maximum shown in table on page 3 and lock jam nut.
6. Open the sprayer agitation valve to get desired spraying pressure.

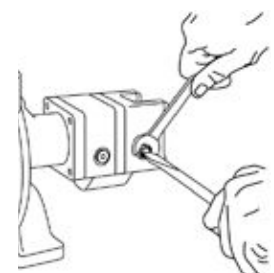

NEEDLE VALVE

PRE-OPERATION SETUP (CONT'D)

Entering And Exiting Operator's Position

IMPORTANT

Follow the instructions in your tractor's operation manual for the correct procedure.

I-2015-018

Entering The Operator's Position

Move to the operator's position, start the engine and release the parking brake.

Leaving The Operator's Position

WARNING

AVOID INJURY OR DEATH

Before you leave the operator's position:

- Always park on a flat level surface.
- Place all controls in NEUTRAL.
- Engage the park brake.
- Stop the engine and remove the key.
- Wait for all moving parts to stop.

W-2015-028

Park the tractor / equipment on a flat level surface.

Place all controls in neutral, engage the park brake, stop the engine and wait for all moving parts to stop. Leave the operator's position.

Connecting The Fertilizer Applicator To The Tractor

Inspect the tractor's drawbar and fertilizer applicator hitch before connecting. (See the tractor's owner's manual.)

Enter the operator's position. (See Entering And Exiting Operator's Position on this page.)

Move the tractor into position in front of the fertilizer applicator. (See the tractor's owner's manual.)

WARNING

AVOID INJURY OR DEATH

Before moving the tractor, look in all directions and make sure no bystanders, especially small children are in the work area. Do not allow anyone between the tractor and the equipment when backing up to the equipment for connecting.

W-2015-029

Move the tractor backwards, aligning the drawbar with the fertilizer applicator's hitch.

NOTE: The jack may need to be lowered or raised for proper alignment of the drawbar and hitch.

If the fertilizer applicator's hitch needs to be adjusted, stop the tractor when drawbar is just in front of the fertilizer applicator's hitch. (See Leveling The Liquid Fertilizer Applicator on Page 40.)

Leave the operator's position. (See Entering And Exiting Operator's Position on this page.)

PRE-OPERATION SETUP (CONT'D)

Connecting The Fertilizer Applicator To The Tractor (Cont'd)

Figure 7

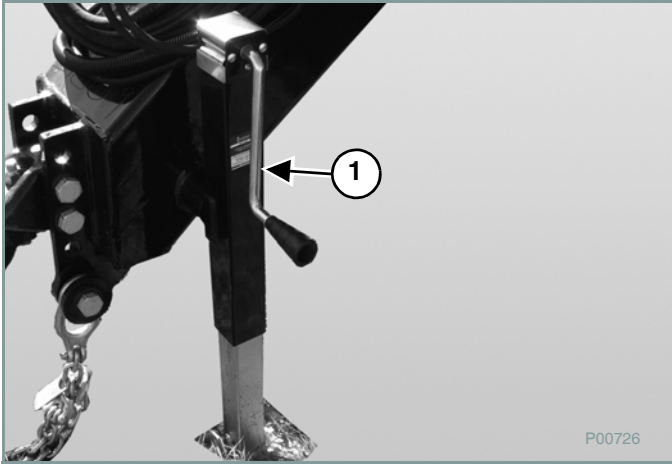

Turn the jack handle (Item 1) [Figure 7] clockwise to raise the hitch or counterclockwise to lower the hitch.

Lower or raise the fertilizer applicator hitch until aligned with the tractor's drawbar.

Move to the operator's seat, start the engine and release the parking brake. (See Entering And Exiting Operator's Position on Page 35.)

Move the tractor backwards, aligning the drawbar hitch pin hole with the fertilizer applicator hitch pin hole(s).

Stop the tractor and leave operator's position. (See Entering And Exiting Operator's Position on Page 35.)

WARNING



CRUSHING HAZARD

Keep fingers and hands out of pinch points when connecting and disconnecting equipment.

W-2014-002

NOTE: Always use a hitch pin of adequate size and strength and a retaining pin with a locking device.

Figure 8

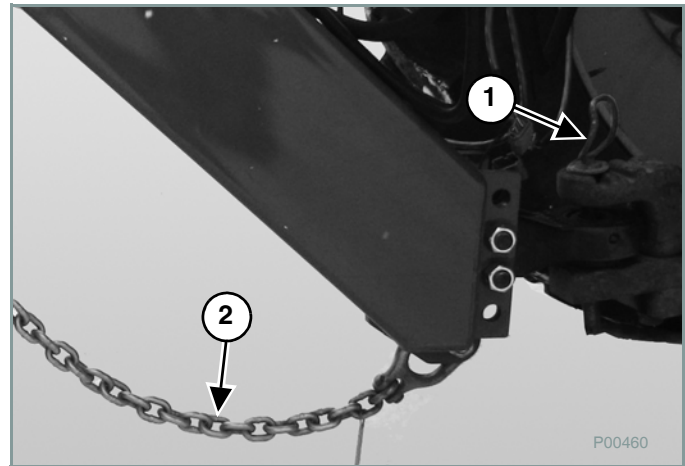

Install the hitch pin (Item 1) [Figure 8] and retaining pin to securely fasten the fertilizer applicator hitch to the tractor drawbar.

Attach the safety chain (Item 2) [Figure 8] around the drawbar.

Turn the jack handle (Item 1) [Figure 7] counterclockwise to lower the hitch (removing weight off of jack).

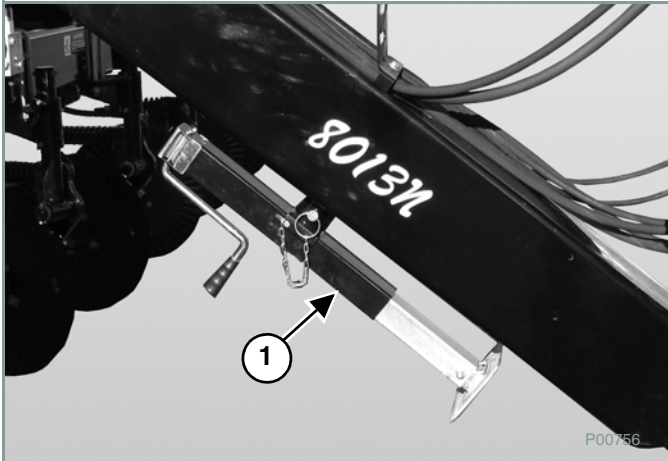
PRE-OPERATION SETUP (CONT'D)**Connecting The Fertilizer Applicator To The Tractor
(Cont'd)****Figure 9**

Place jack (Item 1) [Figure 9] in the stowed position.

PRE-OPERATION SETUP (CONT'D)

Connecting Hydraulic Hoses And Electrical Connections

! WARNING

HIGH PRESSURE FLUID HAZARD

To prevent serious injury or death from high pressure fluid:

- Relieve pressure on system before repairing or adjusting.
- Wear proper hand and eye protection when searching for leaks. Use wood or cardboard instead of hands.
- Keep all components in good repair.

W-2015-030

IMPORTANT

Fluid such as engine oil, hydraulic fluid, coolants, grease, etc. must be disposed of in an environmentally safe manner. Some regulations require that certain spills and leaks on the ground must be cleaned in a specific manner. See local, state and federal regulations for the correct disposal.

I-2015-009

NOTE: Make sure the quick couplers are fully engaged. If the quick couplers do not fully engage, check to see that the couplers are the same size and type.

NOTE: Hydraulic hoses marked with two colored markers (tape) is the pressure line. Hydraulic hoses marked with a single marker (tape) is the return line.

Figure 10

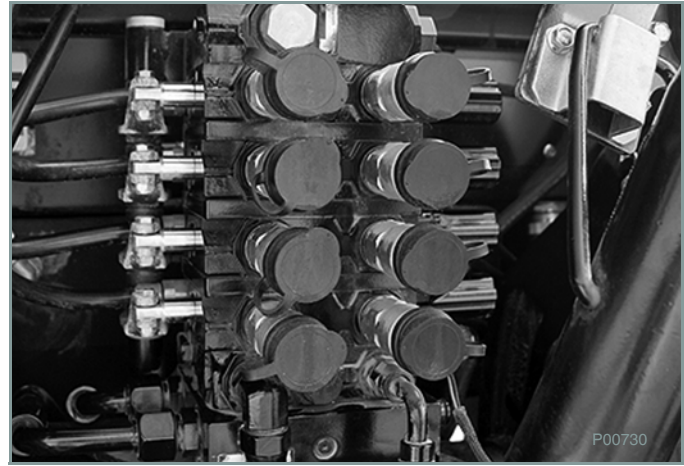

Push male couplers into female couplers on the tractor until they are fully engaged and locked [Figure 10]. Use the chart below for hydraulic hose placement. (See the tractor's Operation And Maintenance manual.)

COLOR	HOSE DESCRIPTION
Red	Pump Pressure
Yellow	Pump Return
Blue	Main Fold Pressure (Lower)
Green	Main Fold Pressure (Raise)
Gray*	Main Lift/Wing Kick Pressure (Lower)
Orange*	Main Lift/Wing Kick Pressure (Raise)
Purple	Flip Fold Pressure (Lower)
Brown	Flip Fold Pressure (Raise)

* - Run in constant flow.

Route electrical line over hitch and connect to tractor's electrical connectors.

NOTE: Be sure to provide slack for turning.

PRE-OPERATION SETUP (CONT'D)

Controls Description

Figure 11

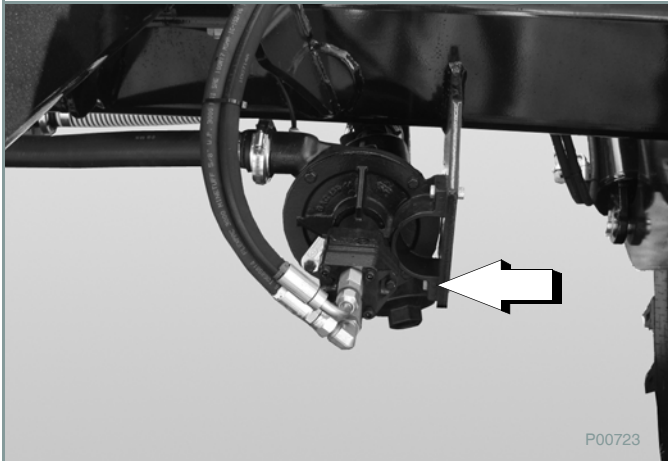

Metering Pump: Is located on the left side in front of the main tire [Figure 11]. (See the metering valve Operator's Manual for operation.)

Figure 12

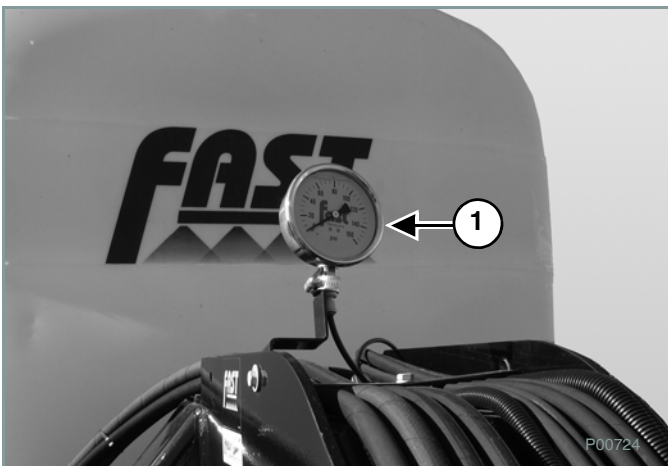

Liquid System Pressure Gauge: Located in front of the main tank (Item 1) [Figure 12]. The gauge monitors pressure in liquid circuit providing flow to injectors. It is normally used to monitor pressure in chemical/fertilizer circuit when setting system for a specific application rate.

NOTE: Monitor gauge during operation. Stop and check system if pressure changes suddenly.

Figure 13

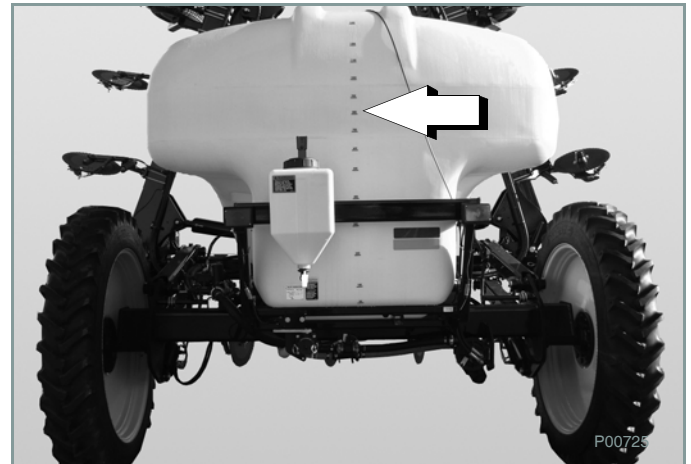

Tank Scale: The back end of tank has a capacity scale molded into it to assist operator when filling tank.

Automatic Controller (Optional): Monitors, sets and controls the operation of the applicator. (See the automatic controller's Operator's Manual for operation.)

PRE-OPERATION SETUP (CONT'D)

Leveling The Liquid Fertilizer Applicator

IMPORTANT

The fertilizer applicator frame must be adjusted down or up until the fertilizer applicator is parallel with the ground prior to operation.

I-2015-019

Lower the toolbar. (See Unfold And Fold Toolbar on Page 41.)

NOTE: The wings and toolbar should be in the operating position before leveling the fertilizer applicator frame.

Figure 14

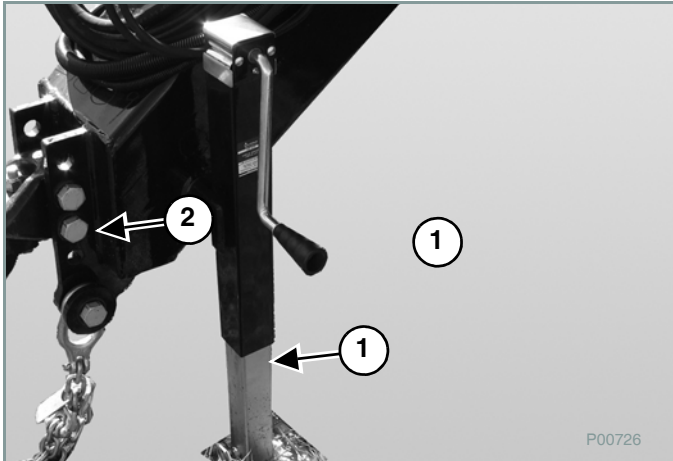

With the liquid fertilizer applicator attached to the tractor, lower the jack from the transport position. Raise the jack (Item 1) until the weight of the fertilizer applicator is on the jack. This will allow the clevis mounting bolts (Item 2) [Figure 14] to be loosened and moved for leveling (if required).

Figure 15

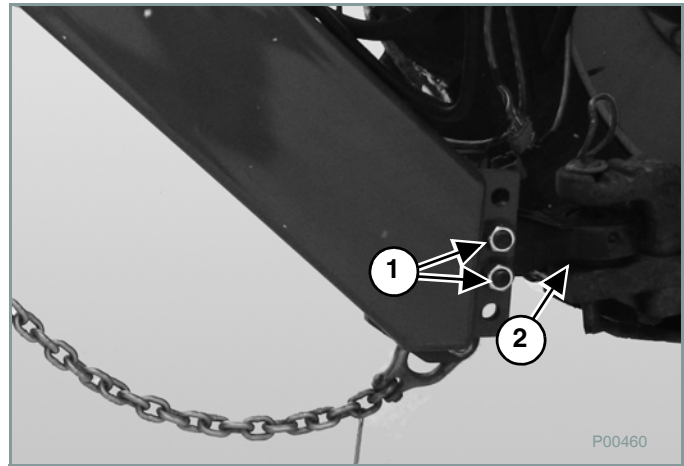

Loosen the clevis mounting bolts (Item 1) [Figure 15].

Figure 16

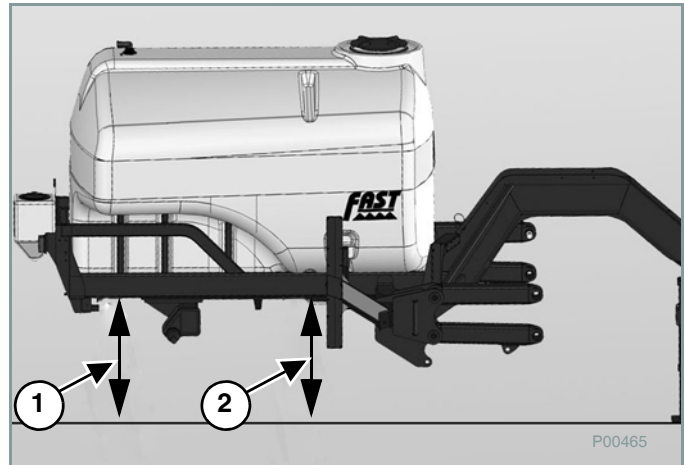

NOTE: Frame and tank [Figure 16] only shown for ease to show measurement locations.

Measure the distance (Items 1 & 2) [Figure 16] from the ground to the bottom of the fertilizer applicator frame in the two locations shown.

NOTE: The two measurements should be approximately the same when the frame is level.

Raise or lower the jack until the fertilizer applicator frame is parallel with the ground. Raise or lower the clevis (Item 2) [Figure 15] to match tractor drawbar and align the closest clevis mounting holes with frame. Install the clevis bolts.

Tighten the clevis mounting bolts (Item 1) [Figure 15] to the correct torque and raise the jack into the storage position.

PRE-OPERATION SETUP (CONT'D)

Unfold And Fold Toolbar

DANGER

ELECTROCUTION HAZARD

To prevent serious injury or death from electrocution:

- Be aware of overhead powerlines.
- Keep away from powerlines when transporting or folding or unfolding wings.
- Electrocution can occur without direct contact.

D-2015-004

DANGER

CRUSH HAZARD

To avoid serious injury or death, keep everyone clear of machine when folding or extending wings.

D-2015-005

WARNING

AVOID INJURY OR DEATH

Before moving the tractor, look in all directions and make sure no bystanders, especially small children are in the work area. Do not allow anyone between the tractor and the equipment when backing up to the equipment for connecting.

W-2015-029

Raise And Lower Toolbar

IMPORTANT

Always have the tractor / fertilizer applicator moving forward at a minimum of 3 mph (5 kmh) when lowering the toolbar to minimize the side load on the coulters when they contact the ground.

I-2015-020

IMPORTANT

PREVENT WING REST DAMAGE

Never engage tractor remote lever to lower center section while main wings are in transport position.

I-2015-021

Move to the operator's position and start the engine. (See Entering And Exiting Operator's Position on Page 35.)

Figure 17



Move tractor's remote lever to pressurize green hydraulic hose to raise center section and wings (Item 1) up off cylinder stops (Item 2) [Figure 17]. (See the tractor's Operation & Maintenance manual.)

PRE-OPERATION SETUP (CONT'D)

Unfold And Fold Toolbar (Cont'd)

Unfold Toolbar

Figure 18

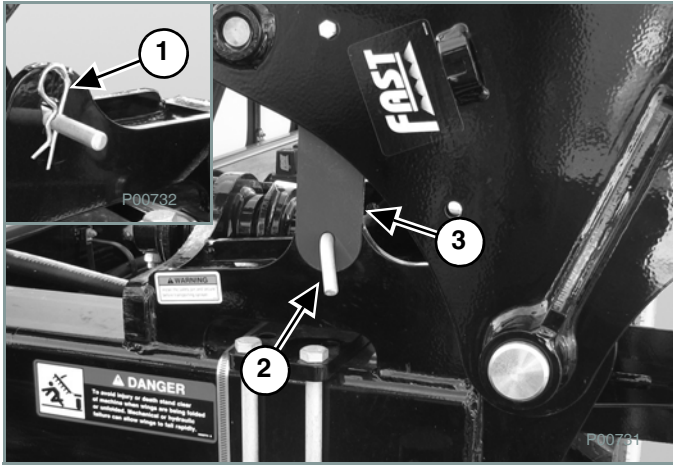

Remove the safety pin (Item 1) and pin (Item 2). Slide the lock plate (Item 3) [Figure 18] away from the pin hole. Install the pin and safety pin.

Figure 19

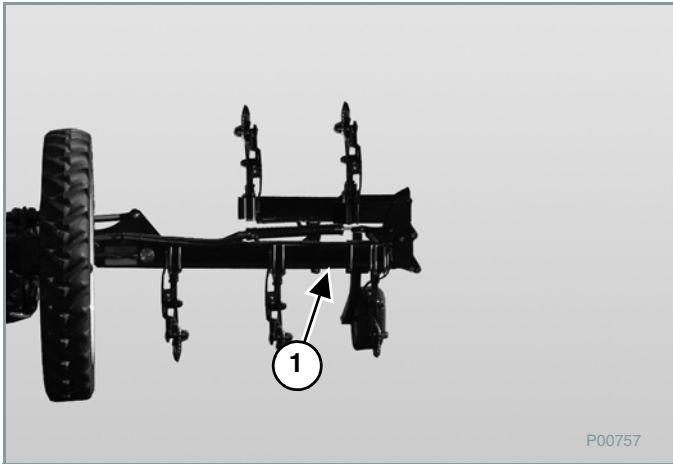

Pressurize the gray hydraulic hose and unfold the wings (Item 1) [Figure 19].

Figure 20

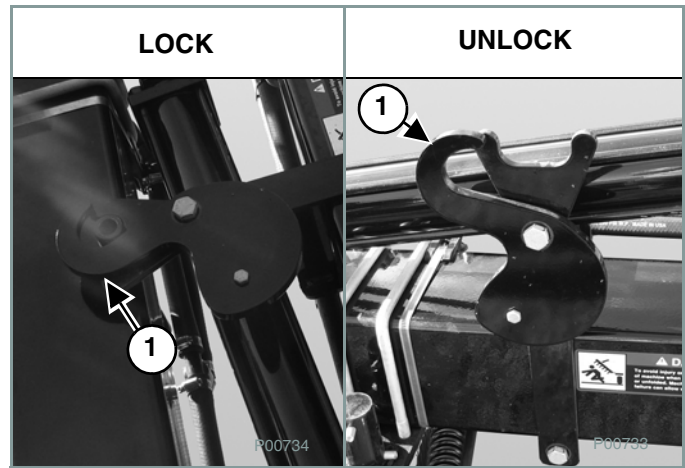

Confirm the flip wing lock (Item 1) [Figure 20] is in the UNLOCK position.

NOTE: The flip wing lock (Item 1) [Figure 20] should automatically lock and unlock.

Figure 21

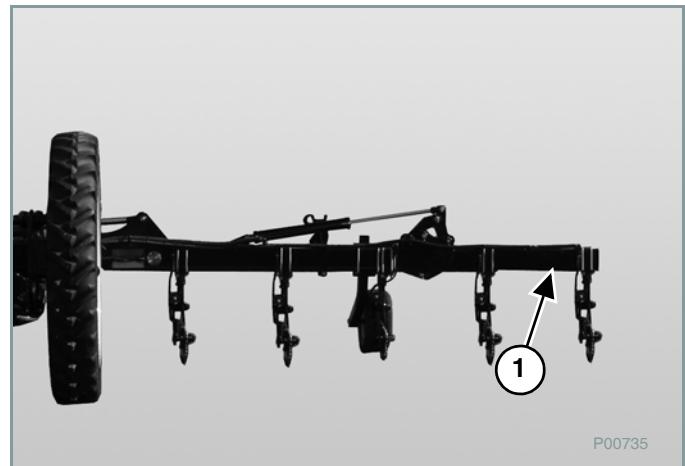

Pressurize the purple hydraulic hose and unfold the outer wing (Item 1) [Figure 21].

PRE-OPERATION SETUP (CONT'D)

Unfold And Fold Toolbar (Cont'd)

Unfold Toolbar (Cont'd)

Figure 22

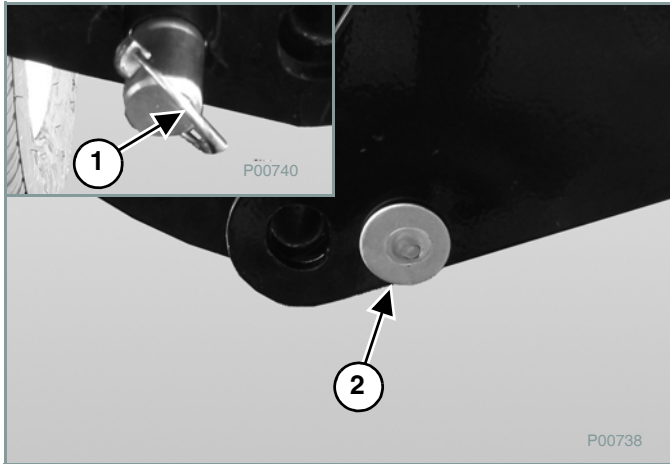

Remove the safety pin (Item 1) and pin (Item 2) [Figure 22].

Figure 23

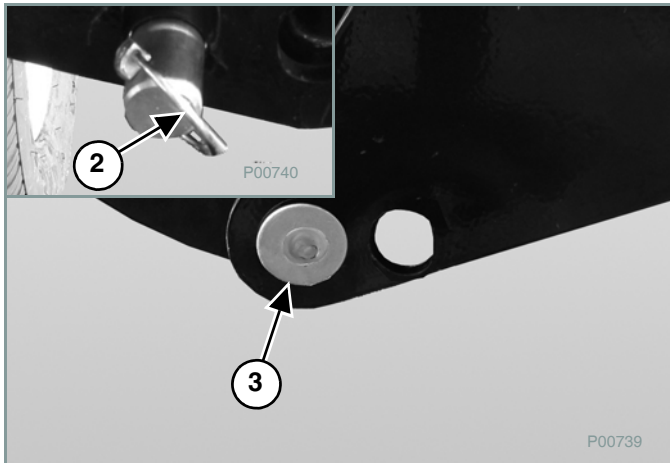

Install the pin (Item 1) in the hole to lock the outer wing. Install the safety pin (Item 2) [Figure 23].

Fold Toolbar

Figure 24

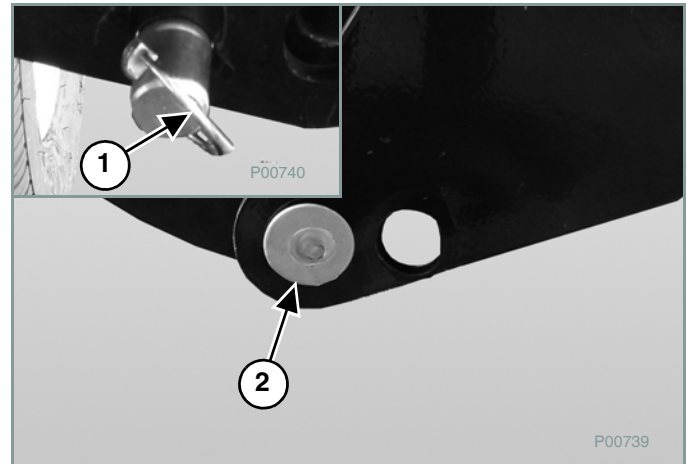

Remove the safety pin (Item 1) and pin (Item 2) [Figure 24].

Figure 25

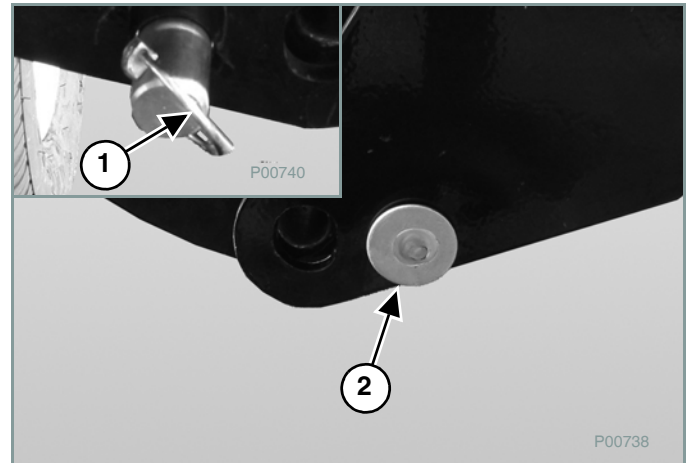

Install the pin (Item 1) in the hole to store the outer wing. Install the safety pin (Item 2) [Figure 22].

PRE-OPERATION SETUP (CONT'D)

Unfold And Fold Toolbar (Cont'd)

Fold Toolbar (Cont'd)

Figure 26

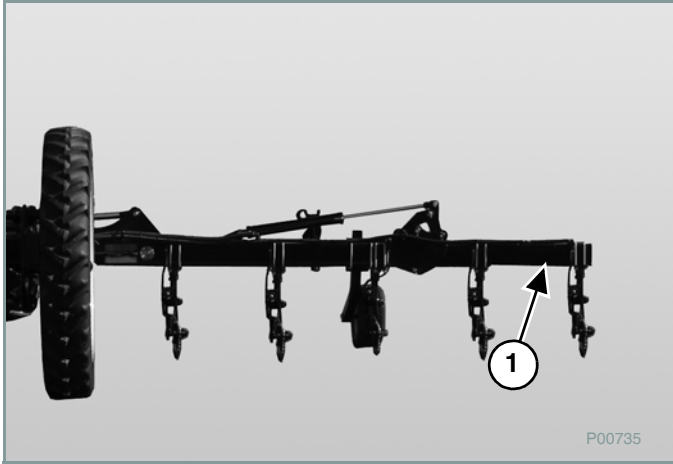

Pressurize the brown hydraulic hose and fold the outer wing (Item 1) [Figure 26].

Figure 27

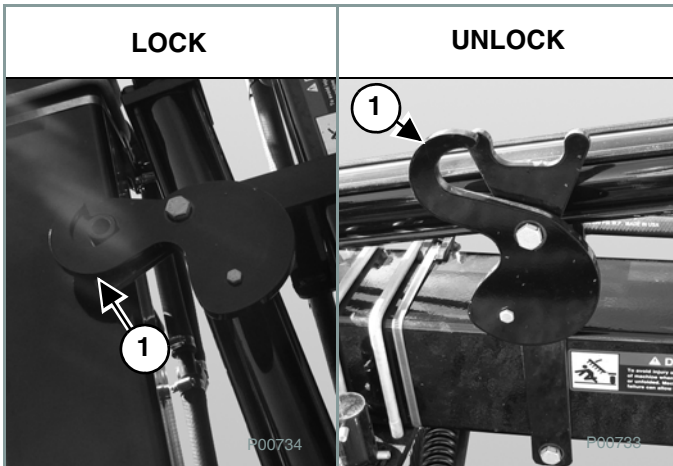

Confirm the flip wing lock (Item 1) [Figure 27] is in the LOCK position.

NOTE: The flip wing lock (Item 1) [Figure 27] should automatically lock and unlock.

Figure 28

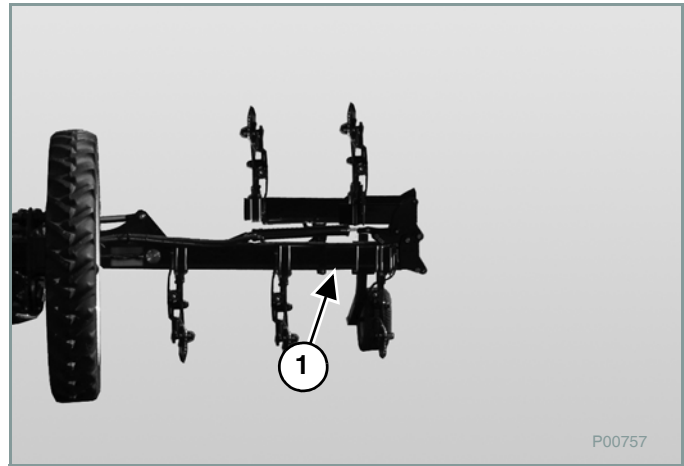

Pressurize the orange hydraulic hose and fold the wings (Item 1) [Figure 28].

Figure 29

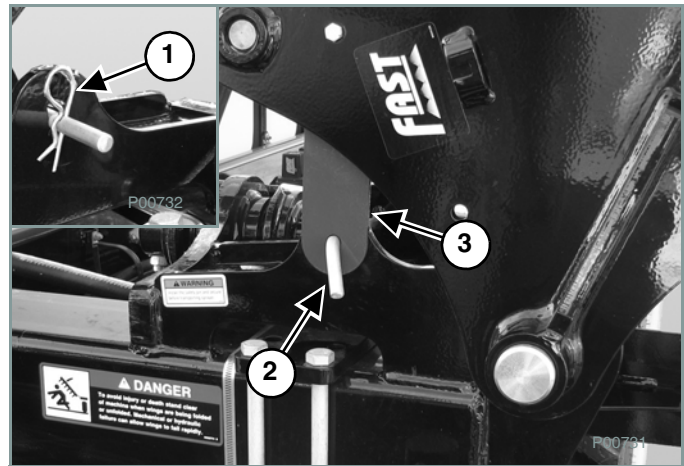

Remove the safety pin (Item 1) and pin (Item 2). Slide the lock plate (Item 3) [Figure 29] to align the pin hole. Install the pin and safety pin.

PRE-OPERATION SETUP (CONT'D)

Coulter Depth/Tool Bar Raise/Lower Adjustments

IMPORTANT

EXCESS PRESSURE COULD CAUSE DAMAGE TO TOOLBAR AND COULTERS.

- Use only as much down pressure as needed to get coulters to proper depth.
- Do not exceed 1500 psi (10342 kPa).

I-2015-022

IMPORTANT

Always have the tractor / fertilizer applicator moving forward at a minimum of 3 mph (5 kmh) when lowering the toolbar to minimize the side load on the coulters when they contact the ground.

I-2015-020

Move to the operator's position and start the engine. (See Entering And Exiting Operator's Position on Page 35.)

To raise the toolbar move the tractor's control to apply pressure to the green hydraulic hose. (See the tractor's Operation & Maintenance Manual.)

To lower the toolbar move the tractor's control to apply pressure to the blue hydraulic hose. (See the tractor's Operation & Maintenance Manual.)

Unfold the liquid fertilizer applicator. (See Unfold And Fold Toolbar on Page 41.)

Figure 30

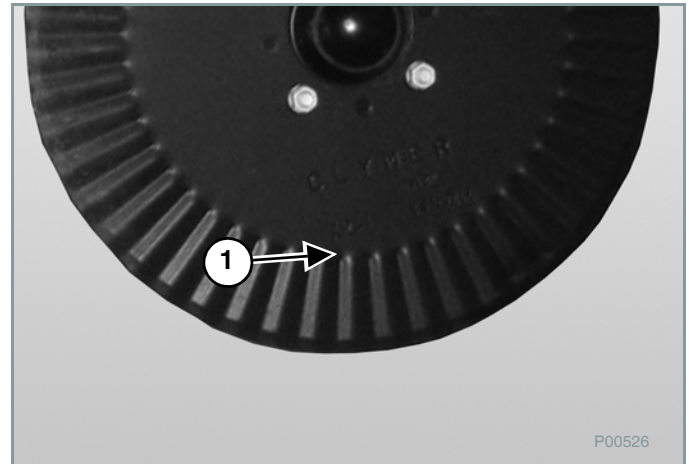

Raise or lower the toolbar until the toolbar coulters are at the desired depth.

NOTE: It is recommended to adjust coulters no deeper than the top of the coulter ripples (Item 1) [Figure 30] 3 in. (76 mm).

Figure 31

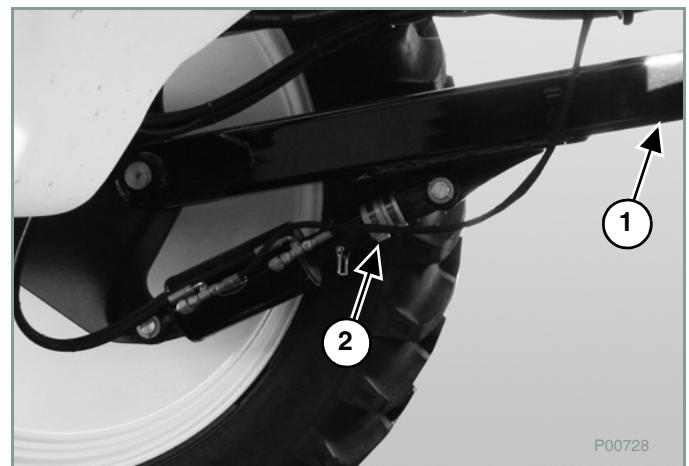

Slightly raise the toolbar. Install spacers (Item 1) [Figure 31] on toolbar lift cylinder ram to give required machine depth.

NOTE: Toolbar can then be fully lowered and always return to same depth.

PRE-OPERATION SETUP (CONT'D)

Coulter Depth/Tool Bar Raise/Lower Adjustments (Cont'd)

Place the main fold pressure (blue hydraulic hose) in constant flow.

Figure 32

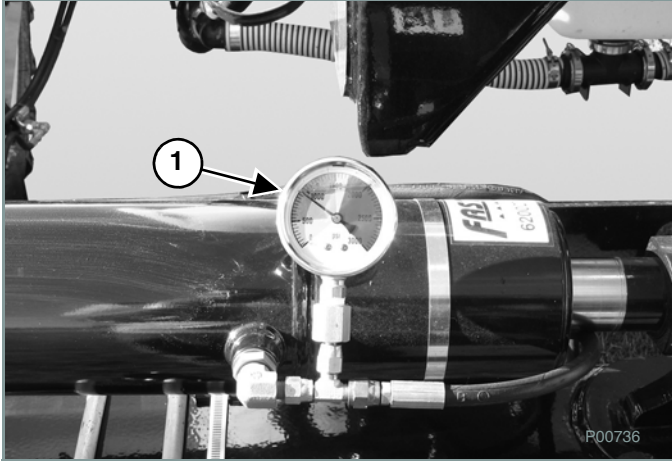

Check amount of down pressure applied to main wings by pressurizing orange tagged hose continuously and lowering coulters into the ground while slow moving ahead with unit. Hydraulic down pressure gauge (Item 1) [Figure 32] should read between 500 and 1500 psi (3447 and 10342 kPa).

Figure 33

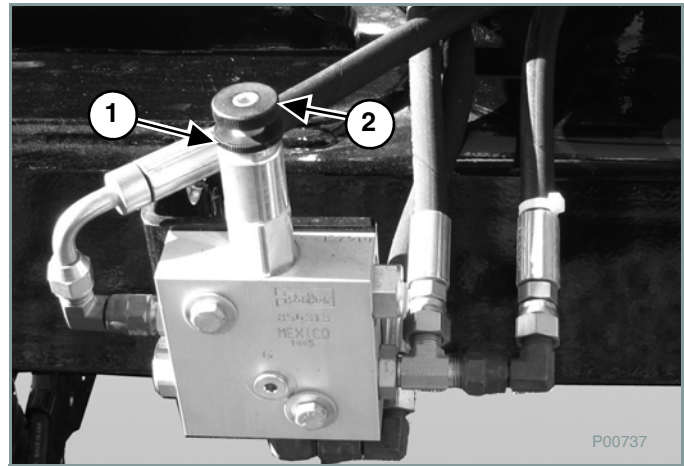

Down pressure may be adjusted by loosening the knurl jam nut (Item 1) and turning the knurl nut (Item 2) [Figure 33] on down pressure valve located on toolbar near wing fold manifold. (See the tractor's Operation & Maintenance Manual.)

If down pressure needs to be adjusted, turn knurl nut (Item 2) [Figure 33] clockwise to increase pressure and turn counter clockwise to decrease down pressure. To change pressure, loosen knurl jam nut (Item 1), turn adjustment stem 1/4 turn at a time. Reverse the tractor remote #1 to fully raise toolbar and kick wings up. Toolbar is now ready for field application.

PRE-OPERATION SETUP (CONT'D)

Coulter Depth/Tool Bar Raise/Lower Adjustments (Cont'd)

Figure 34

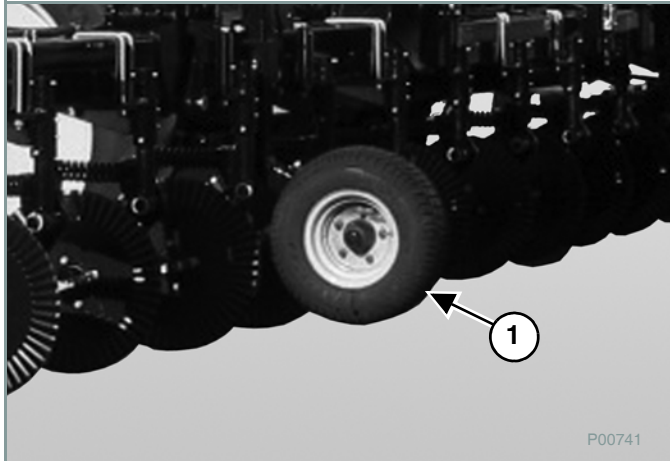

Gauge wheel (Item 1) [Figure 34] helps to maintain application depth in adverse ground conditions.

- Lower gauge wheels if soil conditions are soft.
- Raise gauge wheels if soil conditions are hard to obtain the same application depth.
- Set gauge wheels so wings are level front to back.
- Adjust gauge wheel as required. (See Nozzles on Page 63.)

Figure 35

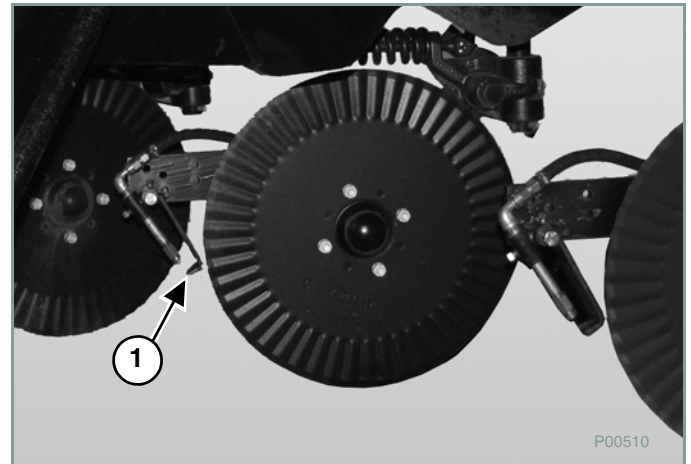

Nozzles/Knives (Item 1) [Figure 35] need to be adjusted to the correct height. (See the nozzle/knife manufacturers instructions.)

NOTE: As a general guideline, tip of nozzle should be slightly above ground as unit moves over the field.

PRE-OPERATION SETUP (CONT'D)

System Screen

! WARNING

AVOID SERIOUS INJURY OR DEATH

- Check chemical or fertilizer MSDS for proper handling instructions.
- Toxic chemicals can enter the body by breathing, spray or contact with bare skin. Do not take a chance with your health and safety.

W-2015-032

Figure 36

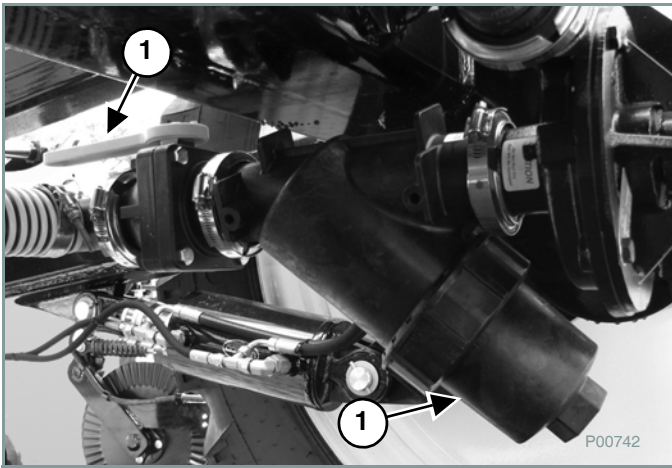

Close valve (Item 1), remove filter bowl and screen (Item 2) [Figure 36] and wash with clean water on a *DAILY BASIS*. Clean liquid is required to prevent nozzle plugging.

NOTE: Collect and dispose of any liquid in a approved container,

FIELD OPERATION

! WARNING



CRUSHING HAZARD

- Before moving the tow vehicle / equipment, look in all directions and make sure no bystanders are in the work area.
- Do not allow anyone between the tow vehicle and the equipment when backing up to the equipment for connecting.

W-2014-005

! WARNING



CRUSHING HAZARD

Keep fingers and hands out of pinch points when connecting and disconnecting equipment.

W-2014-002

! WARNING

AVOID INJURY OR DEATH

Use of an unapproved hitch or tow vehicle can result in loss of control, leading to serious injury or death. Tow vehicle and hitch must have the rated capacity to tow this equipment.

W-2014-004

FIELD OPERATION (CONT'D)

 **WARNING**

Verify that the equipment is securely fastened to the tow vehicle before moving the tow vehicle and equipment.

W-2014-006

 **WARNING**

AVOID INJURY OR DEATH

Pay attention to surrounding areas to prevent being crushed between two pieces of equipment.

W-2013-020

 **WARNING**

AVOID INJURY OR DEATH

Install and secure all guards and shields before starting or operating.

W-2015-019

 **WARNING**

AVOID INJURY OR DEATH

Do not allow riders on the applicator or tractor during operation or transporting.

W-2015-021

 **WARNING**

AVOID INJURY OR DEATH

Clear area of all bystanders, especially children, before starting or filling with chemical or fertilizer.

W-2015-022

 **WARNING**

AVOID INJURY OR DEATH

Do not breathe, touch or ingest chemicals or fertilizer. Always wear protective clothing and follow safe handling procedures.

W-2015-024

 **WARNING**

AVOID INJURY OR DEATH

Read chemical or fertilizer manufacturers warnings, instructions and procedures before starting and follow them exactly.

W-2015-023

 **WARNING**

AVOID INJURY OR DEATH

Stay away from wings when folding or extending wings. Keep others away.

W-2015-025



WARNING

AVOID INJURY OR DEATH

Do not exceed a safe travel speed.

W-2015-026



WARNING

AVOID INJURY OR DEATH

Stay away from overhead power lines when folding or extending the wings and during transport.

W-2015-027

IMPORTANT

Clean reflectors, SMV emblem and lights before transporting.

I-2015-014

IMPORTANT

Attach securely to towing unit using a hardened pin with a retainer and a safety chain.

I-2015-015

IMPORTANT

Use hazard flasher on tractor when transporting.

I-2015-016

IMPORTANT

Verify main tank is empty before transporting on road.

I-2015-017

Attach applicator to machine. (See Connecting The Fertilizer Applicator To The Tractor on Page 35.) & (See Connecting Hydraulic Hoses And Electrical Connections on Page 38.)

Review and follow pre-operation checklist. (See Connecting The Fertilizer Applicator To The Tractor on Page 35.)

Unfold/extend toolbar. (See Unfold And Fold Toolbar on Page 41.)

Set the coulters. (See Coulter Depth/Tool Bar Raise/Lower Adjustments on Page 45.)

Filling spray tank:

- Park tractor and applicator on a flat surface.
- Read and follow chemical/fertilizer manufacturers' instructions.

FIELD OPERATION (CONT'D)**CHEMICAL HAZARD**

To prevent serious injury or death:

WEAR PERSONAL PROTECTIVE EQUIPMENT

- Do not allow chemical or solution to touch skin.
- Some chemicals can be absorbed through the skin.
- Wear rubber gloves and protective gear at all times.

DON'T BREATHE VAPOR

- Avoid chemical splash and vapor. Keep others away.
- Do not breathe vapor.
- Wear proper respirator when working with chemicals.
- Chemicals can be toxic.

DON'T INGEST CHEMICAL

- If in eyes or mouth, read manufacturer's instructions and follow them exactly.
- Seek immediate medical attention.
- Before working with chemicals, know the poison control phone number for your location.

D-2015-006

WARNING
AVOID SERIOUS INJURY OR DEATH

Always read the label before using chemicals. Follow the instructions from the chemical manufacturer on how to select, use and handle each chemical. Note protection information each time before opening the container.

W-2015-035

WARNING
AVOID SERIOUS INJURY OR DEATH

Do not spill chemicals on skin or clothing. If chemicals are spilled, remove contaminated clothing immediately and wash skin (and clothing) thoroughly with soap and water. Wash hands and face with soap and water and change clothing after spraying.

W-2015-034

IMPORTANT

Verify main tank is empty before transporting on road.

I-2015-017

FIELD OPERATION (CONT'D)

Figure 37

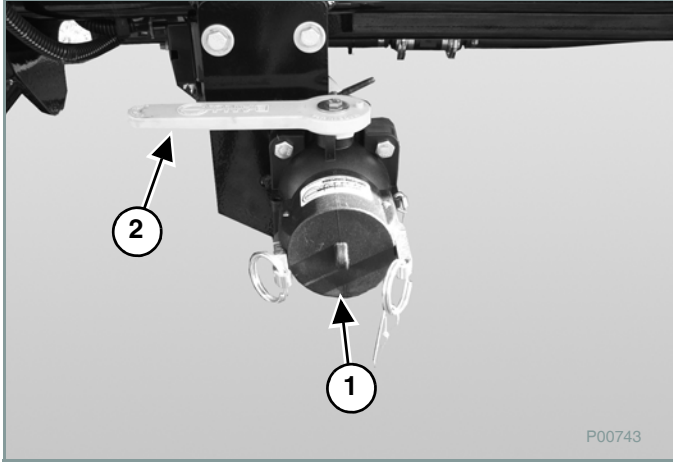

- Move tender truck to applicator.
- Remove cover (Item 1) [Figure 37]
- Connect transfer hose to bottom fill line (Item 2) [Figure 37].
- Start pump on tender truck and open valve on input line. (See tender truck Operation & Maintenance manual.)
- Pump until tank is filled to desired level.

NOTE: Do not overfill.

- Close input valve and stop pump on tender truck. (See tender truck Operation & Maintenance manual.)
- Remove and stow fill line.
- Install and fasten input line covers (Item 1) [Figure 37].

Figure 38

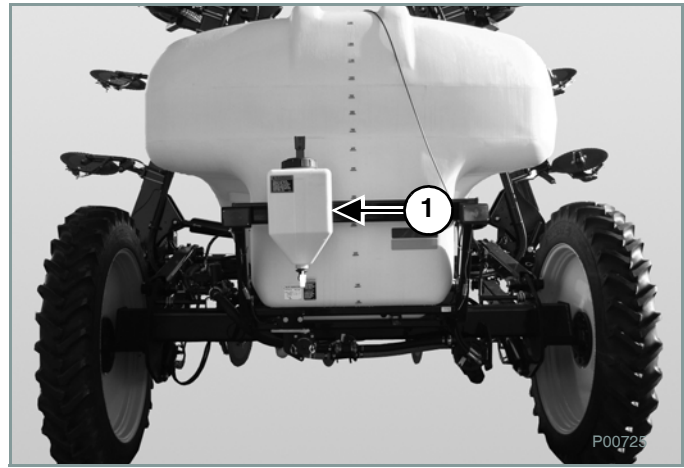

Fresh Water Rinse Tank:

- Fill rinse tank with clean fresh water.

NOTE: Do not allow tank to run low on fresh water. Use water from rinse tank to clean, rinse or wash anything that has become contaminated.

Set applicator controller for **EXACTLY** how much liquid is being applied.

NOTE: Incorrect application rates can dramatically affect seed germination and yields. Set at start of season or when changing application rate.

FIELD OPERATION (CONT'D)

Starting:

- Set engine RPM at rated speed. (See the tractor's Operation & Maintenance manual.)
- Engage tractor's hydraulic system. (See the tractor's Operation & Maintenance manual.)
- Place hydraulic motor control lever in detent. (See the tractor's Operation & Maintenance manual.)
- Start into field.
- Lower the toolbar into ground. (See Unfold And Fold Toolbar on Page 41.)
- Turn on boom sections. (See the applicator controller's Operation & Maintenance manual.)

Stopping:

- Turn off boom sections.
- Place hydraulic motor control lever in *float* position and lift toolbar out of ground.
- Stop forward motion of machine, place hydraulic lever in its off position.
- Reduce engine RPM to low idle.

Emergency stop:

- If an emergency arises, shut engine *off* to stop machine or stop forward motion.

NOTE: When starting after an emergency stop, use starting information on this page.

Set ground speed.

Set desired application rate.

NOTE: Always run at established travel speed.

NOTE: Best results are obtained ground speed is 5 - 8 mph (8 - 13 kph). Ground speed variations in the field will automatically be compensated. Always operate at a comfortable speeds. Do not operate so fast that toolbar or tank bounce while going through field. Effective results require that liquid be applied at a consistent depth in a consistent manner. Machine bouncing will prevent this required consistency.

POST-OPERATION DISCONNECTION



AVOID BURNS

Hydraulic fluid, tubes, fittings and quick couplers can get hot when running equipment. Be careful when connecting and disconnecting quick couplers.

W-2015-031

Release pressure and pull the male coupler out to disconnect. (See the tractor's Operation And Maintenance manual.)

Disconnect electrical connectors from the tractor.

Figure 39

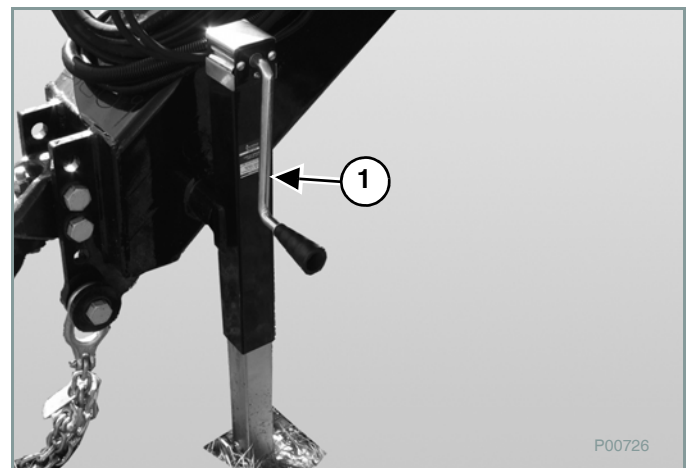

Place the jack in the vertical position.

Turn the jack handle (Item 1) [Figure 39] clockwise to raise the hitch until the weight of the applicator is on the jack.



ELECTROCUTION HAZARD

To prevent serious injury or death from electrocution:

- Be aware of overhead powerlines.
- Keep away from powerlines when transporting or folding or unfolding wings.
- Electrocution can occur without direct contact.

D-2015-004



AVOID SERIOUS INJURY OR DEATH

Daybreak and dusk are particularly dangerous and pilot vehicles are recommended.

W-2015-033



PREVENT EQUIPMENT DAMAGE.

Verify main tank is empty before transporting on road.

I-2015-025



- Check with local authorities regarding applicator transport on public roads. Obey all applicable laws and regulations.
- Always travel at a safe speed. Use caution when making corners or meeting traffic.
- Make sure SMV (Slow Moving Vehicle) emblem and all lights and reflectors that are required by the local highway and transport authorities are in place, are clean and can be seen clearly by all overtaking and oncoming traffic.

I-2015-024



PREVENT EQUIPMENT DAMAGE.

Be sure applicator is hitched securely to towing vehicle and a retainer is used through drawbar pin. Always attach a safety chain between frame and towing vehicle.

I-2015-026

NOTE: Keep to right and yield right-of-way to allow faster traffic to pass. Drive on the road shoulder, if permitted by law.

Be sure all bystanders are clear of machine.

Be sure that applicator is properly connected to towing vehicle. Always attach safety chain between machine and tractor and install a retainer through drawbar pin.

Keep safe distance from overhead power lines when folding or extending the wings.

Install transport lock spacers on lift cylinders before transporting.

Note: Add more lock spacers to prevent the toolbar from dropping during transport.

Depending on machine configuration, wheels may need to be moved in, inverted or duals removed to reduce machine transport width to 18 feet or less.

Make sure SMV (Slow Moving Vehicle) emblem and all lights and reflectors that are required by local highway and transport authorities are in place, are clean and can be seen clearly by all overtaking and oncoming traffic.

DO NOT transport faster than 20 mph (32 kmh). Follow chart below for travel speeds.

MAXIMUM TRAVEL SPEED	WEIGHT OF FULLY EQUIPPED APPLICATOR VERSES WEIGHT OF TOW VEHICLE
20 mph (32 kmh)	1 to 1 or less
10 mph (16 kmh)	2 to 1 or less
DO NOT TOW	More than 2 to 1

STORAGE INSTRUCTIONS **WARNING****AVOID SERIOUS INJURY OR DEATH**

- **Store unit in an area away from human activity.**
- **Do not permit children to play on or around stored applicator.**

W-2015-036

Storage

At end of season, thoroughly inspect and prepare applicator for storage. Repair or replace any worn or damaged components to prevent any unnecessary down time at beginning of next season.

- Empty remaining liquid from the tanks.
- Open liquid line connections, screen canister and pump. Drain all fluids out of system. Reinstall all plugs.
- Use 10 gal (38 l) Marine RV Anti freeze, pump through screens, valve, nozzles/check valves and orifices/tips.

NOTE: Do not use liquid fertilizer as anti-freeze.

- Thoroughly wash applicator using a pressure washer.
- Lubricate the equipment.
- Inspect all hydraulic hoses, couplers and fittings. Replace or repair as necessary.
- Inspect all liquid lines and connections. Replace or repair as necessary.
- Touch up all paint nicks and scratches to prevent rusting.
- Install spacers on all lift cylinder rams.
- Move machine to a storage position.
- Select an area that is dry, level and free of debris.
- Unhook applicator from tractor.

Re-Commissioning

After the FAST AG Solutions equipment has been in storage, it is necessary to follow a list of items to return the equipment to service.

- Clear area of bystanders, especially small children, and remove foreign objects from machine and working area.
- Attach tractor to applicator.
- Check:
 - Attach and secure all liquid lines
 - Coulters and nozzles
 - All hardware
 - Tire pressure
 - All hydraulic lines, fittings and connections
- Lubricate the equipment
- Replace any defective parts
- Add a small amount of liquid to tank. Turn pump metering system on momentarily and confirm it turns freely.
- Turn metering pump on momentarily and check that liquid comes out of each nozzle.
- Follow pre-operation checklist. (See Pre-Operation Checklist on Page 33.)





MAINTENANCE AND REPAIR

MAINTENANCE AND REPAIR SAFETY PRECAUTIONS59

PREVENTATIVE MAINTENANCE59

 Eight Hours Or Daily59

 Annually61

 Service Record62

MAINTENANCE PROCEDURES63

 Nozzles63

 Adjust Gauge Wheel Height63

SPECIFICATIONS64

 Settings64

 Lubricants64

 Torque Values65

TROUBLESHOOTING66

 Chart66



MAINTENANCE AND REPAIR SAFETY
PRECAUTIONS

WARNING



CRUSHING HAZARD

Keep fingers and hands out of pinch points when connecting and disconnecting equipment.

W-2014-002

WARNING

AVOID INJURY OR DEATH

Use of an unapproved hitch or tow vehicle can result in loss of control, leading to serious injury or death. Tow vehicle and hitch must have the rated capacity to tow this equipment.

W-2014-004

WARNING

AVOID SERIOUS INJURY OR DEATH

Lower machine to the ground, place all controls in neutral, stop engine, set park brake, remove ignition key, and wait for all moving parts to stop before servicing, adjusting, repairing or unplugging.

W-2015-037

PREVENTATIVE MAINTENANCE

IMPORTANT

PREVENT EQUIPMENT DAMAGE.

When lubricating the equipment:

- Use only a hand-held grease gun for all greasing.
- Wipe grease fitting with a clean cloth before greasing, to avoid injecting dirt and grit.
- Replace and repair broken fittings immediately.
- If a fitting will not take grease, remove and clean thoroughly. Clean and lubricant passageway. Replace fitting if necessary.

I-2015-027

Eight Hours Or Daily

Figure 40

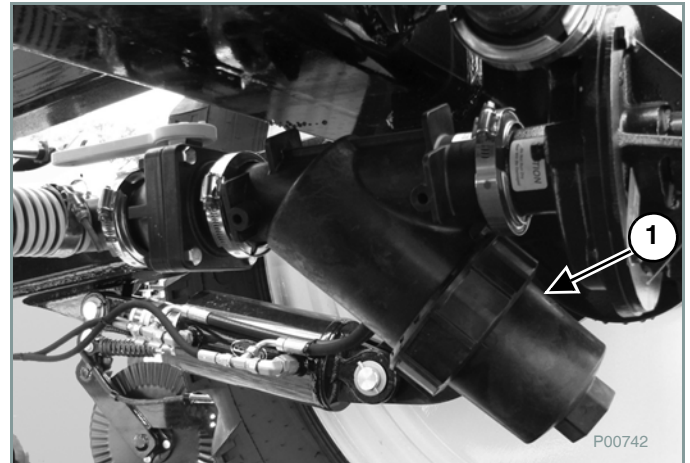

Remove filter bowl and wash fertilizer strainer screen (Item 1) [Figure 40] using clean water.

PREVENTATIVE MAINTENANCE (CONT'D)

Eight Hours Or Daily (Cont'd)

Figure 41

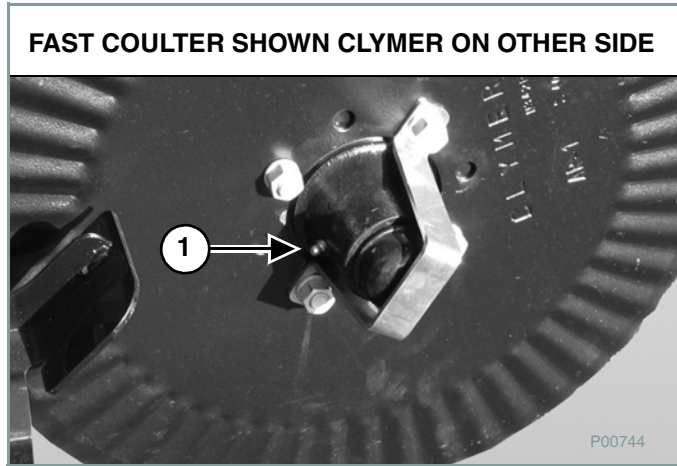
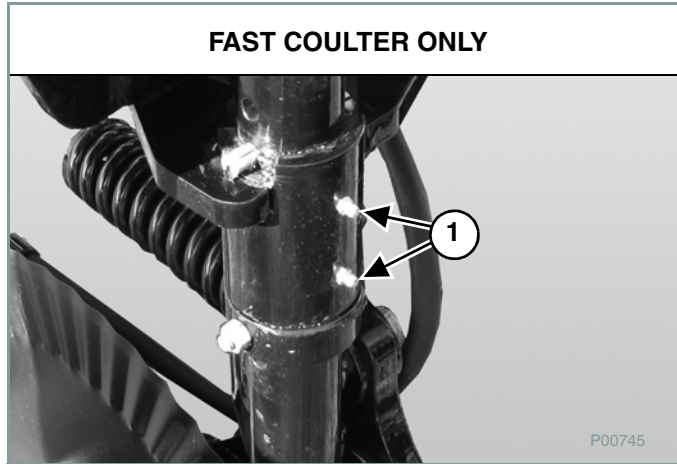

Figure 42



Lubricate coulters (Item 1) [Figure 41] and [Figure 42].

Figure 43



Lubricate gauge wheel hubs [Figure 43].

Figure 44

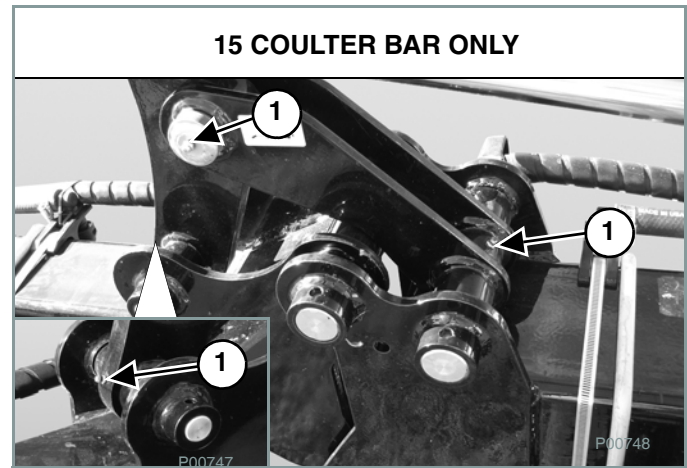

Lubricate outer wing pivots (Item 1) [Figure 44].

Figure 45

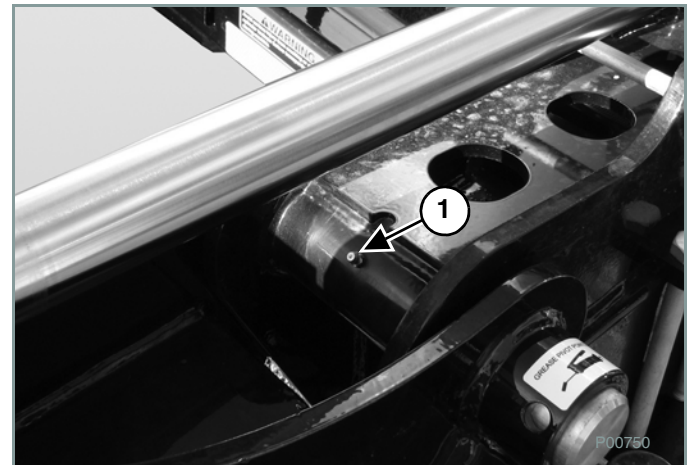

Lubricate flex hinge on wing pivot (Item 1) [Figure 45].

PREVENTATIVE MAINTENANCE (CONT'D)

Eight Hours Or Daily (Cont'd)

Figure 46

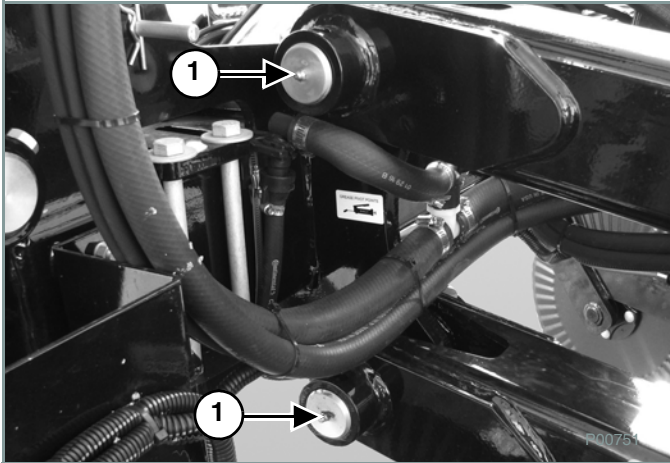

Lubricate front parallel link pivots (Item 1) [Figure 46].

Figure 47

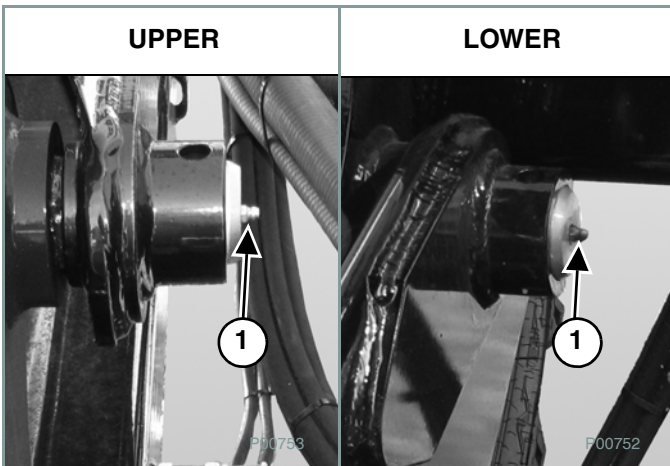

Lubricate rear parallel link pivots (Item 1) [Figure 47].

Annually

Figure 48

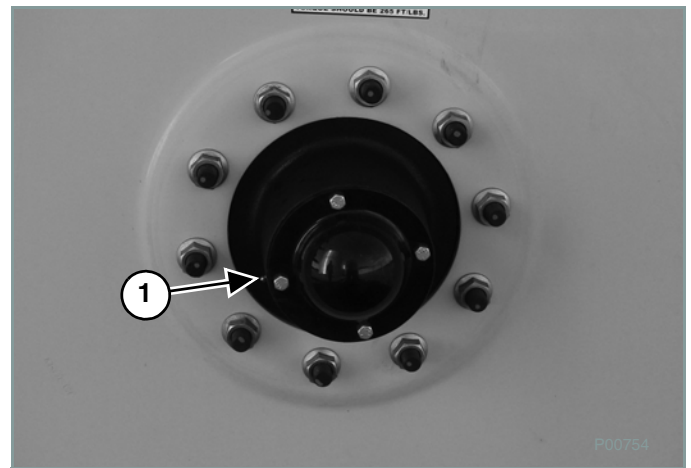

Grease wheel bearings (Item 1) [Figure 48].

PREVENTATIVE MAINTENANCE (CONT'D)

Service Record

ITEM	HOURS												
	SERVICED BY												
8 Hours or Daily													
Strainer Screen (C)													
Toolbar Linkage (L)													
Flip Wing Hinges (L)													
Inner Wing Hinges (L)													
Annually													
Wheel Bearings (L)													

(C)-Cleaning

(L)-Lubricating

Place a check mark (.) next to the item completed.

Copy this page to continue service record history.

ITEM	HOURS												
	SERVICED BY												
8 Hours or Daily													
Strainer Screen (C)													
Toolbar Linkage (L)													
Flip Wing Hinges (L)													
Inner Wing Hinges (L)													
Annually													
Wheel Bearings (L)													

(C) - Cleaning

(L) - Lubricating

Place a check mark (✓) next to the item completed.

Copy this page to continue service record history.

MAINTENANCE PROCEDURES

! WARNING

Check for correct function after adjustments, repairs or service. Failure to make needed repairs or adjustments can cause injury or death.

W-2013-003

Nozzles

! WARNING

AVOID SERIOUS INJURY OR DEATH

- Check chemical or fertilizer MSDS for proper handling instructions.
- Toxic chemicals can enter the body by breathing, spray or contact with bare skin. Do not take a chance with your health and safety.

W-2015-032

! WARNING

AVOID SERIOUS INJURY OR DEATH

Lower machine to the ground, place all controls in neutral, stop engine, set park brake, remove ignition key, and wait for all moving parts to stop before servicing, adjusting, repairing or unplugging.

W-2015-037

Extend wings and raise toolbar to its fully upright position. (See *Unfold And Fold Toolbar* on Page 41.)

Place safety stands under center toolbar or install transport lock spacers over lift cylinder rams.

Remove lock pin (Item 1) and pin (Item 2) [Figure 50] and adjust gauge wheel height as desired.

Figure 49

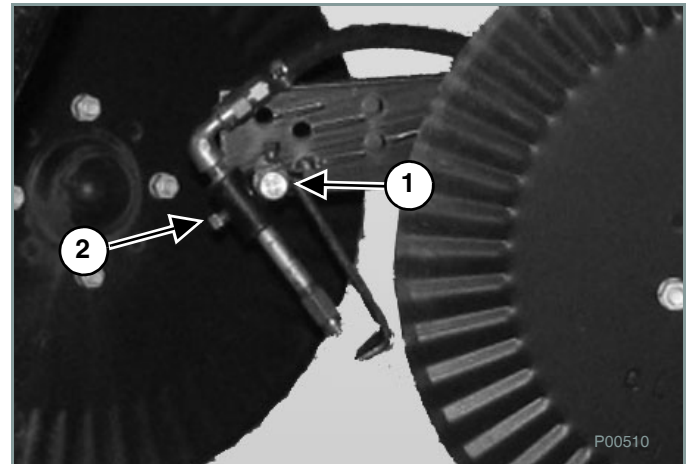

Adjust Nozzle Angle

Loosen setscrew (Item 1) [Figure 49] to set nozzle at required angle and centered behind coulter.

NOTE: The best results are obtained when nozzle directs liquid approximately 1 inch (25 mm) behind coulter.

Nozzle Spray Pattern

Loosen setscrew (Item 2) [Figure 49] to adjust nozzle spray parallel with furrow.

NOTE: Sight along nozzle and coulter. Nozzle should direct liquid directly behind coulter.

Adjust Gauge Wheel Height

Figure 50

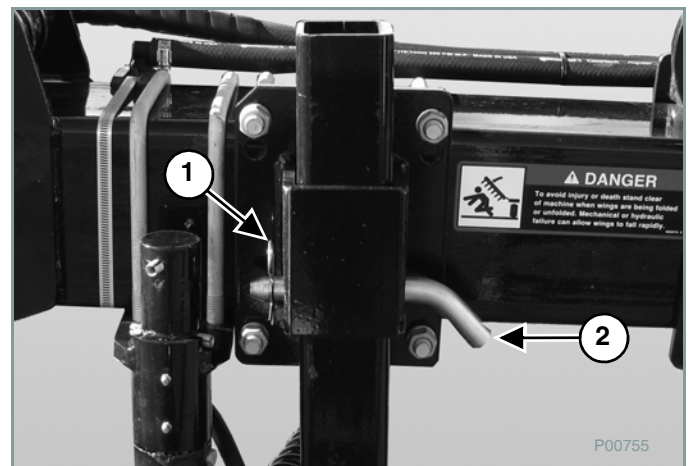

Install pin (Item 2) and lock pin (Item 1) [Figure 50].

SPECIFICATIONS

Settings

Not Applicable

Lubricants

Use an SAE multi-purpose high temperature grease with extreme pressure (EP) performance. Also acceptable is an SAE multi-purpose lithium base grease.

SPECIFICATIONS (CONT'D)
Torque Values

The following table shows standard torque specifications for bolts.

	Thread Size	SAE Grade 5	SAE Grade 8
in-lb (N•m)	0.250 1/4	80 - 90 (9.0 - 10.2)	110 - 120 (12.4 - 13.6)
	0.3125 5/16	180 - 200 (20.3 - 22.6)	215 - 240 (24.2 - 27.1)
ft-lb (N•m)	0.375 3/8	25 - 28 (34 - 38)	35 - 40 (47 - 54)
	0.4375 7/16	40 - 45 (54 - 61)	60 - 65 (81 - 88)
	0.500 1/2	65 - 70 (88 - 95)	90 - 100 (122 - 136)
	0.5625 9/16	90 - 100 (122 - 136)	125 - 140 (170 - 190)
	0.625 5/8	125 - 140 (170 - 190)	175 - 190 (240 - 260)
	0.750 3/4	220 - 245 (300 - 330)	300 - 330 (410 - 450)
	0.875 7/8	330 - 360 (450 - 490)	475 - 525(645 - 710)
	1.000 1	475 - 525 (645 - 710)	725 - 800 (985 - 1085)
	1.125 1 1/8	650 - 720 (880 - 975)	1050 - 1175 (1425 - 1600)
	1.250 1 1/4	900 - 1000 (1200 - 1360)	1475 - 1625 (2000 - 2200)
	1.375 1 3/8	1200 - 1350 (1630 - 1830)	2000 - 2200 (2720 - 2980)
	1.500 1 1/2	1500 - 1650 (2040 - 2240)	2600 - 2850 (3530 - 3870)
	1.625 1 5/8	2000 - 2800 (2720 - 2980)	3450 - 3800 (4680 - 5150)
	1.750 1 3/4	2500 - 2750 (3390 - 3730)	4300 - 4800 (5830 - 6500)
	1.875 1 7/8	3150 - 3500 (4270 - 4750)	5500 - 6100 (7450 - 8300)
	2.000 1	3800 - 4200 (5150 - 5700)	6500 - 7200 (8800 - 9800)

TROUBLESHOOTING

Chart

 <b style="font-size: 24pt; margin-left: 10px;">WARNING	<p>Instructions are necessary before operating or servicing equipment. Read and understand the Operation, Maintenance & Parts Manual, signs (decals) on equipment. Follow warnings and instructions in the manuals when making repairs, adjustments or servicing. Check for correct function after adjustments, repairs or service. Untrained operators and failure to follow instructions can cause injury or death.</p> <p style="text-align: right; font-size: 10pt;">W-2013-002</p>
--	---

Use the following troubleshooting chart to locate and correct problems which most often occur with the equipment.

PROBLEM	CAUSE	CORRECTION
Wings will not extend.	Lock valve is closed.	Open lock valve.
Applicator will not turn on.	No power.	Connect power line to 12 volt power source in tractor cab.
	Line valve is closed.	Open line valve.
	Filter screen is plugged.	Remove filter and clean screen.
Coulter does not penetrate the ground.	Down-load pressure too low.	Increase down-load pressure to the inner or outer wing as needed.
	Gauge wheel is set too low.	Raise gauge wheel(s) as needed.
Coulter penetrates too far into the ground.	Down-load pressure too high.	Decrease down-load pressure to the inner or outer wing as needed.
	Gauge wheel is set too high.	Lower gauge wheel(s) as needed.
Wings shutter / chatter when folded/unfolded.	Hydraulic flow too high.	Lower hydraulic flow to fold/unfold circuit to 6 - 15 gpm (22.71 - 56.78 lpm).
Toolbar shutters chatters when raised.	Hydraulic flow too high.	Lower hydraulic flow to raise/lower circuit to 6 - 15 gpm (22.71 - 56.78 lpm).



ILLUSTRATED PARTS LISTS

ILLUSTRATED PARTS LIST69

Introduction69

Part Procurement69

Explanation Of Notations69

8010N/8013N Liquid Fertilizer Applicator70

Cart/Main Frame Assembly (Hitch And Jack)72

Cart/Main Frame Assembly (Middles Section)74

Cart/Main Frame Assembly (Rear Section)76

Axle Assemblies78

Parallel Links80

Tire And Rim82

Center Section Assembly84

Inner Wing Assembly (Left And Right)86

Gauge Wheel Assembly88

FAST Coulter Assembly90

Coulter Knife Assembly92

Injector Arm Assembly94

1050 - 1350 Tank Assemblies96

Fill Valve To Tank To Pump Plumbing99

Ball Valve To Tank To Pump Plumbing Supporting Hardware100

Tank Tee To Ball Valve To Pressure Gauge102

Toolbar Plumbing104

Ace FMC-150F-HYD-206 & FMC-150FS-HYD-206 Pump106

Directo valve® Electric 2-Way Ball Valve Manifold108

1-1/2 In. Poly Control Valve Assembly (063-0171-894)110

Flowmeter, Raven, RFM60 P Assembly (063-0171-793)111

Raven SCS440 Console112

Electrical Schematic Control Console Harness (155-0171-085)114

Electrical Schematic Control Console Harness (155-0159-856)115

Electrical Schematic Control Console Harness (155-0171-086)116

Product Controller Liquid System, 16 Pin Product Cable118

Cable, 17 Ft., ISO, Hitch To Raven ECU Assembly (115-0172-034)120

Raven, Cable, Adapter, ISO To Active Terminator Assembly (115-0171-963)122

Hydraulic System124

Pump Hydraulic System126

Lighting127





ILLUSTRATED PARTS LIST

Introduction

These parts lists are broken down into sub assemblies.
For locations of the part's lists see page 70.

Part Procurement

To order parts have the serial number of the equipment available. (See Equipment Serial Number on Page 4.)
Contact:

FAST AG Solutions
4130 Commerce Boulevard
Windom, MN 56101
507-427-3861

Explanation Of Notations

The parts lists are broken down into four columns:

- **ITEM NO.** - These numbers are found on the illustration associated with the parts list.
- **PART NO.** - These are the part numbers associated to the ITEM NO.
- **DESCRIPTION** - This is the description of the part.
- **QTY.** - This is the quantity of parts needed in an assembly.
- **NS** - Not Shown
- **AR** - As Required
- **NA** - Not Applicable

ILLUSTRATED PARTS LIST (CONT'D)

8010N/8013N Liquid Fertilizer Applicator

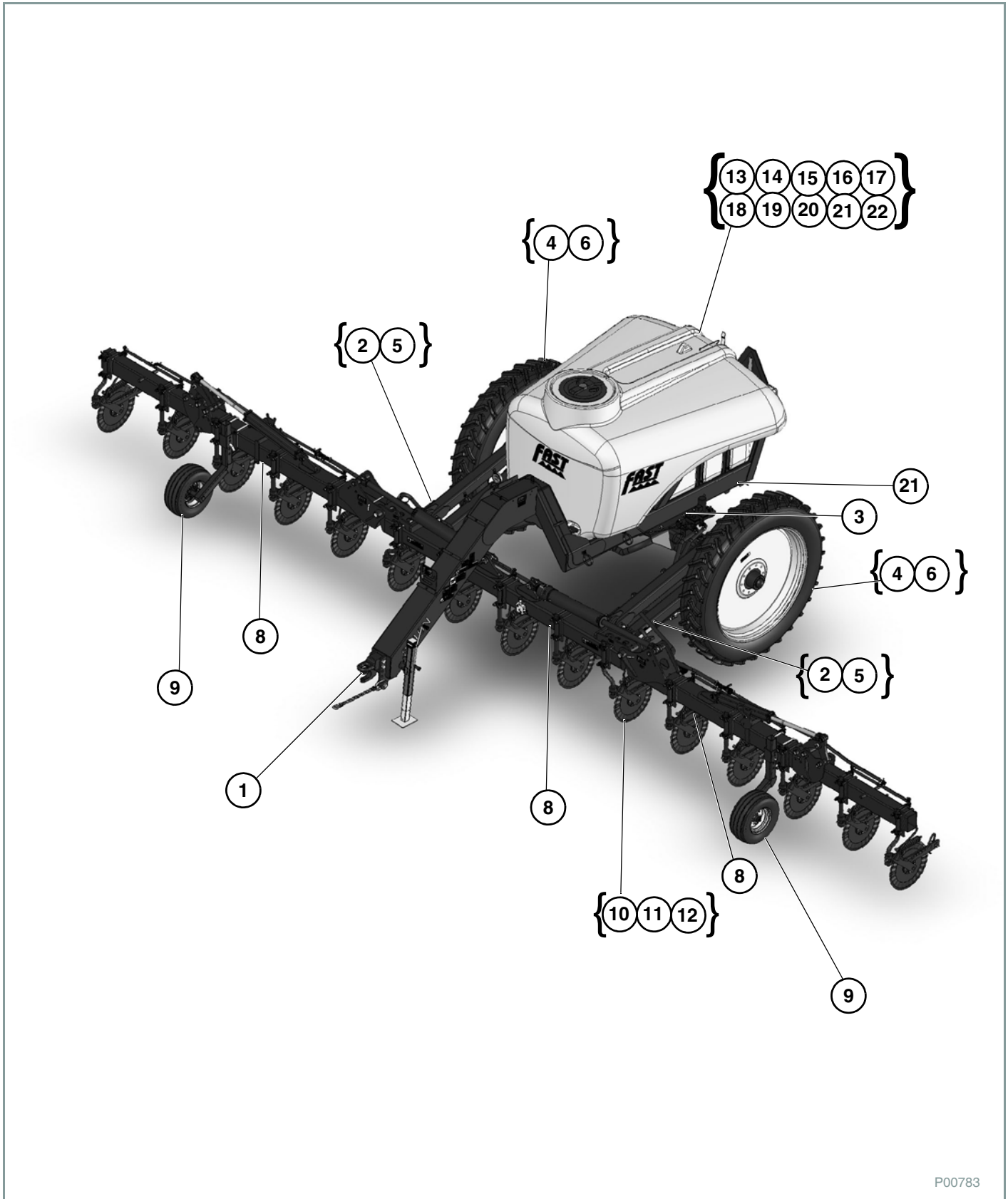

P00783



ITEM NO.	DESCRIPTION	PAGE #
1	CART/MAIN FRAME ASSEMBLY (HITCH AND JACK)	72
2	CART/MAIN FRAME ASSEMBLY (MIDDLES SECTION)	74
3	CART/MAIN FRAME ASSEMBLY (REAR SECTION)	76
4	AXLE ASSEMBLIES	78
5	PARALLEL LINKS	80
6	TIRE AND RIM	82
7	CENTER SECTION ASSEMBLY	84
8	INNER WING ASSEMBLY (LEFT AND RIGHT)	86
9	GAUGE WHEEL ASSEMBLY	88
10	FAST COULTER ASSEMBLY	90
11	COULTER KNIFE ASSEMBLY	92
12	INJECTOR ARM ASSEMBLY	94
13	1050 - 1350 TANK ASSEMBLIES	96
14	FILL VALVE TO TANK TO PUMP PLUMBING	99
15	BALL VALVE TO TANK TO PUMP PLUMBING SUPPORTING HARDWARE	100
16	TANK TEE TO BALL VALVE TO PRESSURE GAUGE	102
17	TOOLBAR PLUMBING	104
18	ACE FMC-150F-HYD-206 & FMC-150FS-HYD-206 PUMP	106
19	DIRECTOVALVE® ELECTRIC 2-WAY BALL VALVE MANIFOLD	108
20	1-1/2 IN. POLY CONTROL VALVE ASSEMBLY (063-0171-894)	110
21	FLOWMETER, RAVEN, RFM60 P ASSEMBLY (063-0171-793)	111
NS	RAVEN SCS440 CONSOLE	112
NS	ELECTRICAL SCHEMATIC CONTROL CONSOLE HARNESS (155-0171-085)	114
NS	ELECTRICAL SCHEMATIC CONTROL CONSOLE HARNESS (155-0159-856)	115
NS	ELECTRICAL SCHEMATIC CONTROL CONSOLE HARNESS (155-0171-086)	116
NS	PRODUCT CONTROLLER LIQUID SYSTEM, 16 PIN PRODUCT CABLE	118
NS	CABLE, 17 FT., ISO, HITCH TO RAVEN ECU ASSEMBLY (115-0172-034)	120
NS	RAVEN, CABLE, ADAPTER, ISO TO ACTIVE TERMINATOR ASSEMBLY (115-0171-963)	122
NS	HYDRAULIC SYSTEM	124
NS	PUMP HYDRAULIC SYSTEM	126
22	LIGHTING	127

ILLUSTRATED PARTS LIST (CONT'D)

Cart/Main Frame Assembly (Hitch And Jack)

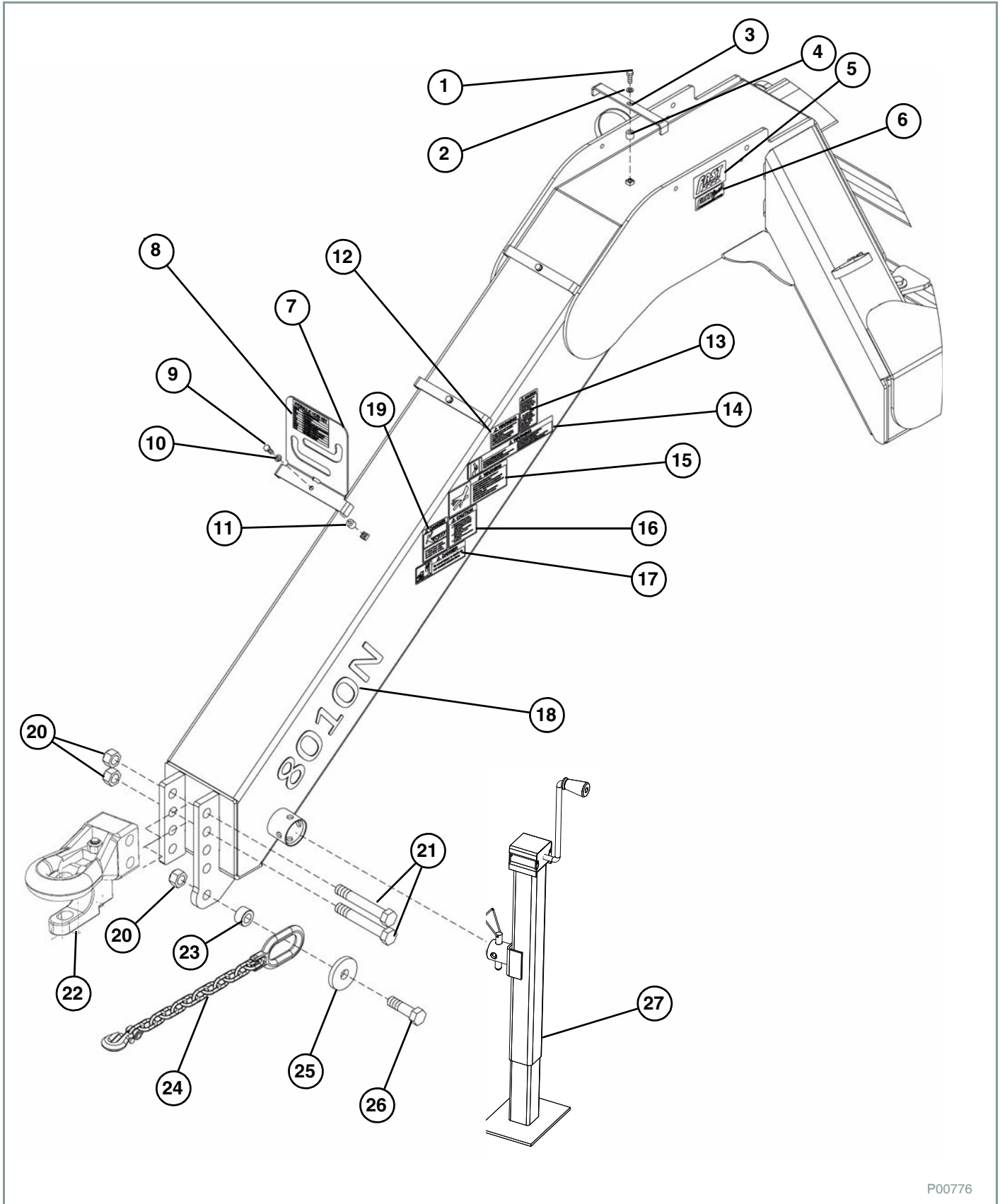

P00776

ILLUSTRATED PARTS LIST (CONT'D)
Cart/Main Frame Assembly Cart/Main Frame Assembly (Hitch And Jack) (Cont'd)

ITEM NO.	PART NO.	DESCRIPTION	QTY.
1	596128M	BOLT, HH 3/8-16 X 1 GR5 MAGNI	6
2	596250M	LOCKWASHER 3/8 MAGNI	12
3	15558	BRACKET, HOSE	3
4	15566	SPACER, HOSE BRACKET	4
5	800020	DECAL, FAST LOGO BLK/GRY	2
6	800023	DECAL, POWDER COAT	2
7	800088	DECAL, HOSE KEY	1
8	22707	BRACKET, HOSE HOLDER	1
9	596128M	BOLT, HH 3/8-16 X 1 GR5 MAGNI	6
10	596250M	LOCKWASHER 3/8 MAGNI	12
11	15566	SPACER, HOSE BRACKET	4
12	800099	DECAL, WARNING-CHARGE WITH OIL	1
13	800101	DECAL, CAUTION-AG CHEMICAL	2
14	800104	DECAL, WARNING-DO NOT SPEED	1
15	800098	DECAL, WARNING-HYDRAULIC FLUID	1
16	800100	DECAL, CAUTION-SHIELDS	1
17	800112	DECAL, DANGER-ELECTRIC LINES	1
18	800170	DECAL, 8010N	2
	800171	DECAL, 8013N	2
19	800103	DECAL, DANGER-RUNOVER	1
20	596234M	NUT, HEX NYLOCK 1-8 MAGNI	3
21	596208M	BOLT, HH 1-8X6-3/4 GR5 MAGNI	2
22	90SAHITCHSM	SUB ASSY, HITCH, CAT 3	1
23	15835	BUSHING, SAFETY CHAIN SPACER	1
24	790049	SAFETY CHAIN, 25,000LB	1
25	15829	WASHER PLATE, SAFETY CHAIN	1
26	596201M	BOLT, HEX 1-8X3-1/2 GR5 MAGNI	1
27	790005	JACK STAND	1

ILLUSTRATED PARTS LIST (CONT'D)

Cart/Main Frame Assembly (Middles Section)

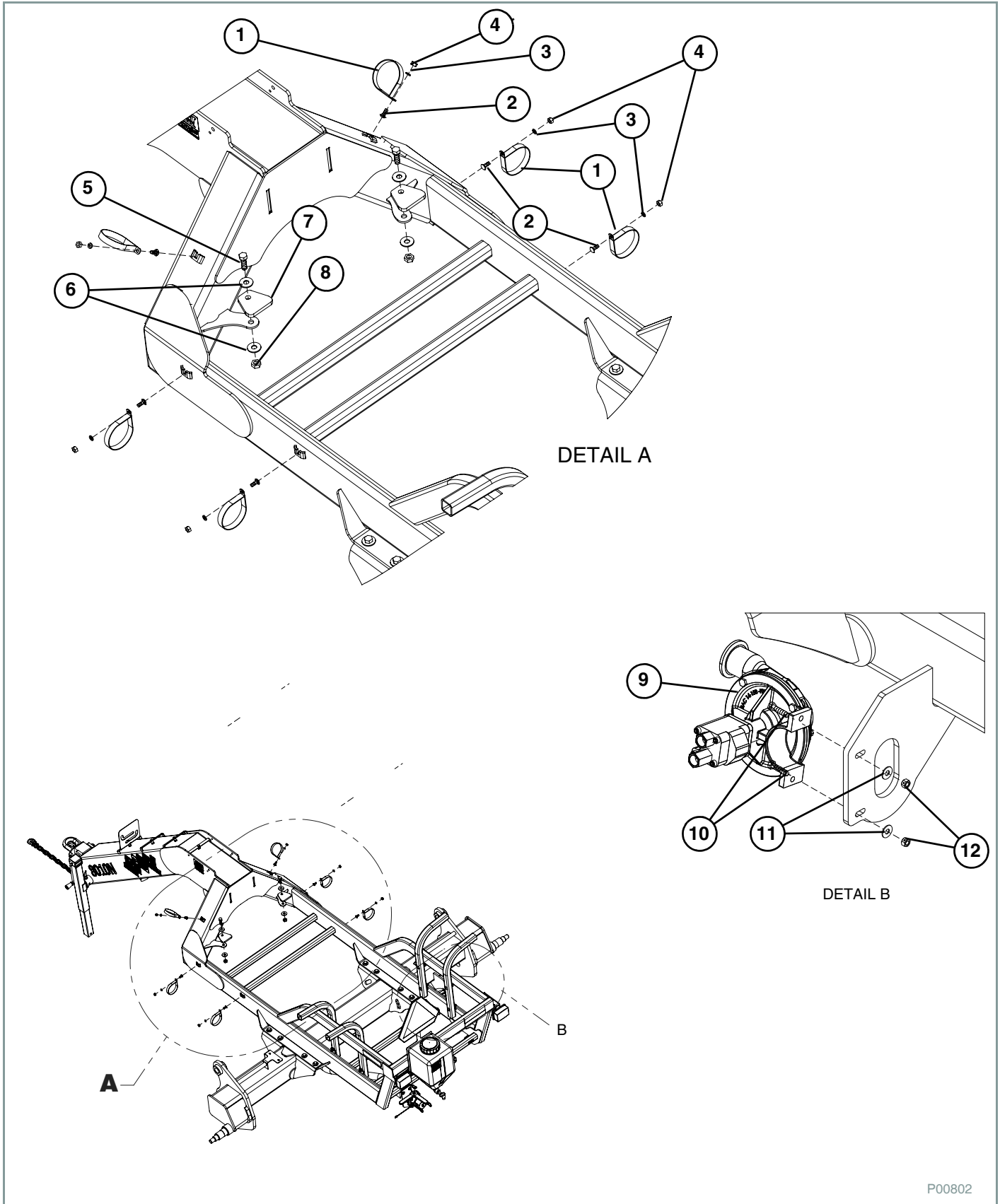



ILLUSTRATED PARTS LIST (CONT'D)

Cart/Main Frame Assembly (Middles Section) (Cont'd)

ITEM NO.	PART NO.	DESCRIPTION	QTY.
1	540053	P-CLAMP, 4" W/ 3/8" HOLE	6
2	596592M	BOLT, CARR., 3/8-16 X 1" MAGNI	6
3	596250M	LOCKWASHER 3/8 MAGNI	6
4	596213M	NUT HEX MAGNI	2
5	596170M	BOLT, HH 5/8-11X2 GR5 MAGNI	2
6	596261M	WASHER, FLAT 5/8 MAGNI	4
7	590023	TAB, HOLD DOWN	2
8	596240M	NUT, CENTERLOCK, 5/8-11 MAGNI	2
9	550000	PUMP, 150-206 FLANGED, ACE (SEE ACE FMC-150F-HYD-206 & FMC-150FS-HYD-206 PUMP ON PAGE 106.)	1
10	596129M	BOLT, HH 3/8-16X1-1/2 GR5 MAGNI	2
11	596258M	WASHER, FLAT 3/8 MAGNI	2
12	596237M	NUT, CENTERLOCK 3/8 MAGNI	2

ILLUSTRATED PARTS LIST (CONT'D)

Cart/Main Frame Assembly (Rear Section)

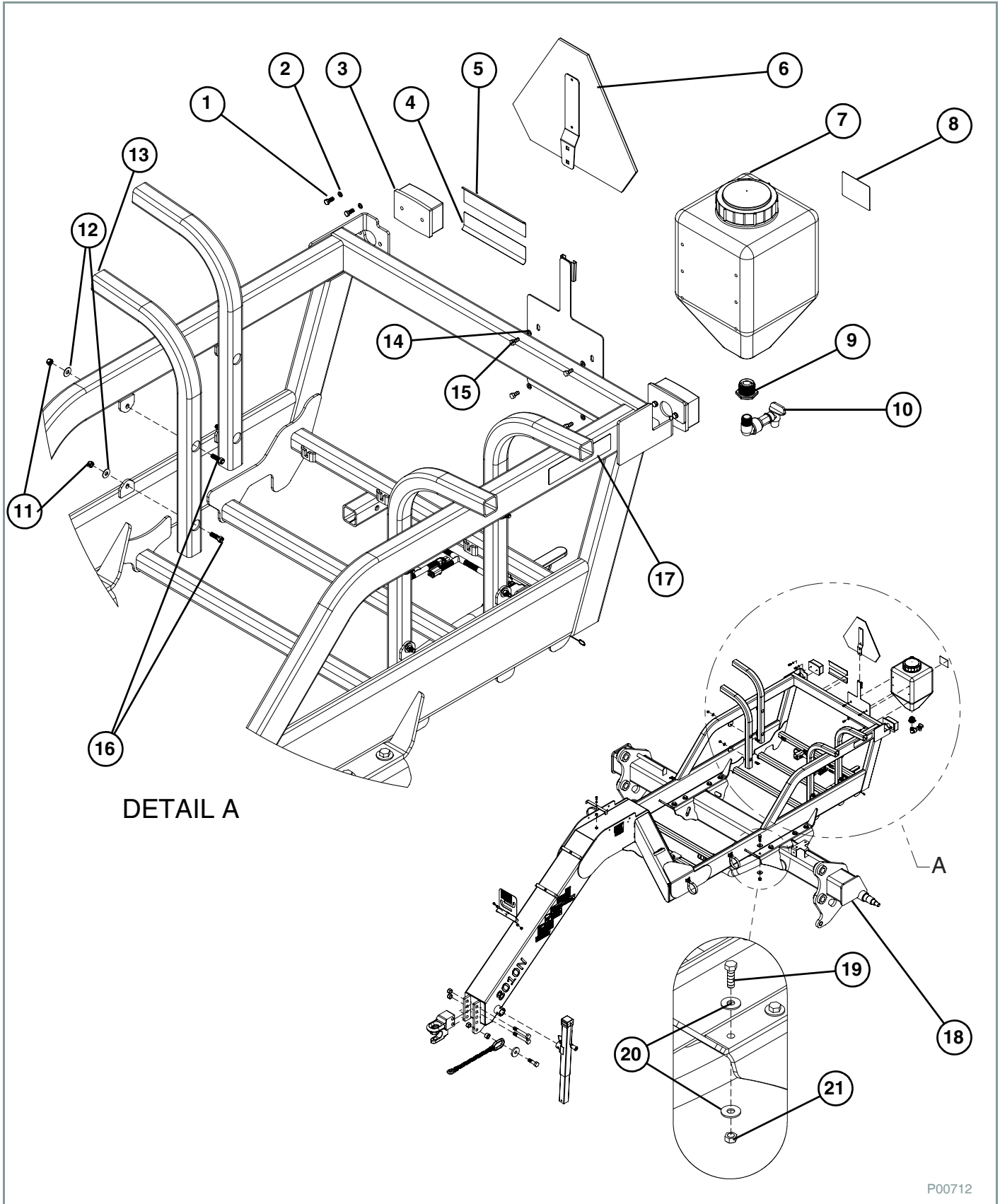

ILLUSTRATED PARTS LIST (CONT'D)
Cart/Main Frame Assembly (Rear Section) (Cont'd)

ITEM NO.	PART NO.	DESCRIPTION	QTY.
1	596737M	BOLT, HH 8-1.25 X 20MM 8.8 MAGNI	4
2	596728M	LOCKWASHER 8MM MAGNI	4
3	740025	LIGHT, RED SURF MNT ASSY	2
4	800109	DECAL, RED REFLECTOR	1
5	800111	DECAL, ORANGE REFLECTOR	1
6	90SASMV	SMV ASSEMBLY	1
7	570125	5 GAL RINSE TANK YELLOW	1
	570094	5 GAL RINSE TANK WHITE	1
8	800108	DECAL, WARNING-RINSE TANK N302108	1
9	530143	1-1/4INCHMPTX3/4INCHFPT REDUCE	1
10	90SAFCHWF	FC HAND WASH FAUCET ASSY	1
11	596237M	3/8 NUT CENTERLOCK	6
12	596258M	WASHER, FLAT 3/8 MAGNI	6
13	18187	FENDER SUPPORT	4
14	596114M	BOLT, HH 5/16-18X3/4 GR5 MAGNI	4
15	596249M	LOCKWASHER 5/16 MAGNI	4
16	596635M	BOLT HEX HD 3/8 X 1-1/4 GR5	8
17	800110	DECAL, AMBER REFLECTOR	2
18	22658	WLDMT, AXLE, 15K, 120" SPC (8013N) 320/90 R46	1
	22659	WLDMT, AXLE, 7K, 120" SPC (8010N) 13.6X38	1
19	596170M	BOLT, HH 5/8-11X2 GR5 MAGNI	16
20	596261M	WASHER, FLAT 5/8 MAGNI	32
21	596232M	NUT, HEX NYLOCK 5/8-11 MAGNI	16

ILLUSTRATED PARTS LIST (CONT'D)

Axle Assemblies

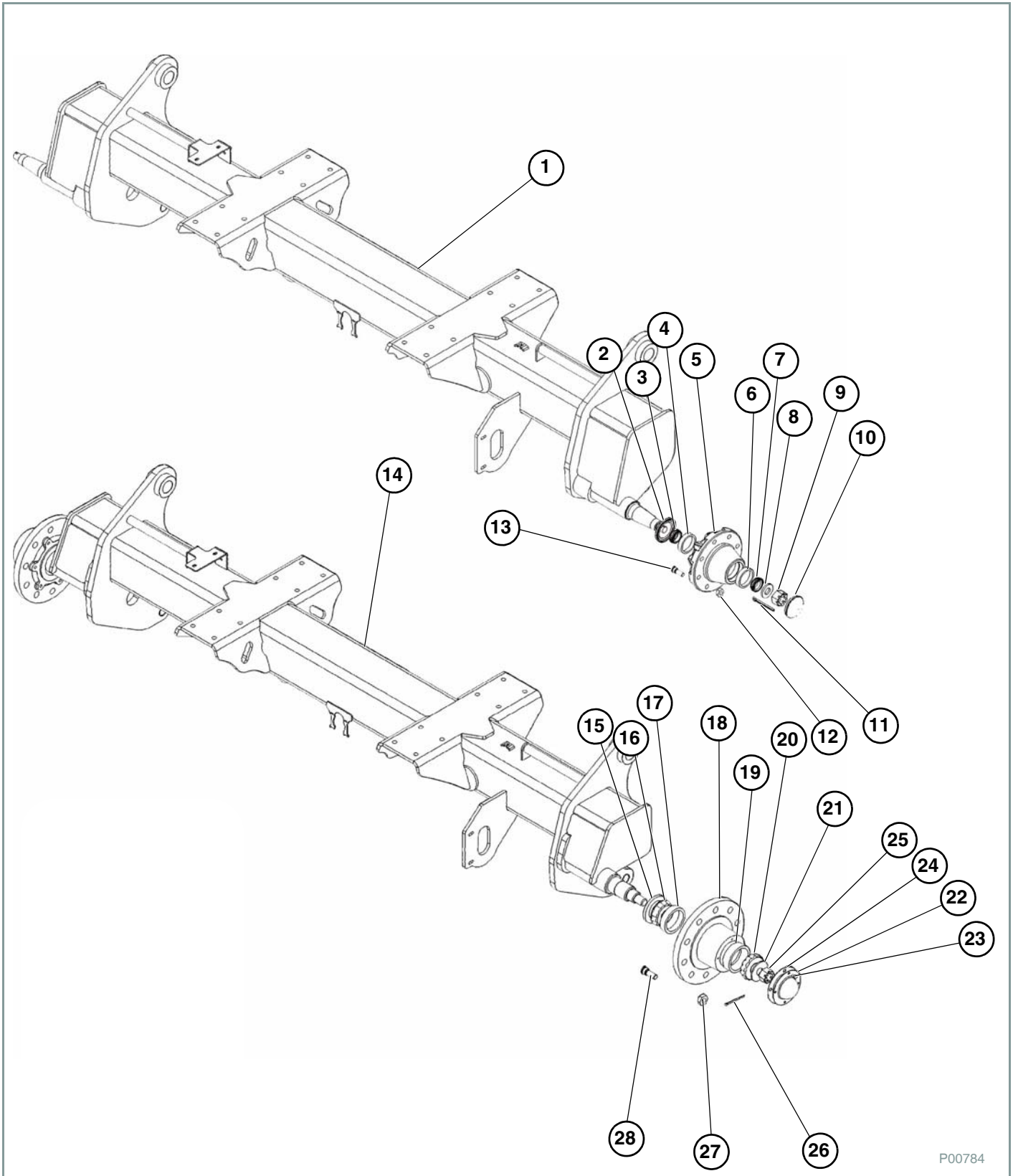

P00784

ILLUSTRATED PARTS LIST (CONT'D)
Axle Assemblies (Cont'd)

ITEM NO.	PART NO.	DESCRIPTION	QTY.
1	22659	AXLE ASSEMBLY 8 BOLT	1
2	730083	SEAL 8 BOLT	2
3	730020	CONE INNER	2
4	730058	CUP INNER	2
5	730059	HUB 8 BOLT WITH CUPS	2
6	730057	CUP OUTER	2
7	730021	CONE OUTER	2
8	730022	WASHER SPINDLE	2
9	730023	NUT SPINDLE	2
10	730019	HUB CAP	2
11	730025	PIN COTTER	2
12	730024	NUT WHEEL	16
13	NI943541	STUD WHEEL	16
14	22658	AXLE ASSEMBLY 10 BOLT	2
15	730013	SEAL 873 SERIES HUB	2
16	730054	CONE INNER 873 SERIES HUB	2
17	1678	CUP INNER 873 SERIES HUB	2
18	730002	HUB 10 BOLT W/CUPS	2
19	730074	CUP OUTER (910332/453A)	2
20	730012	CONE OUTER (910334/460)	2
21	730018	WASHER SPINDLE (913632)	2
22	730072	HUB CAP Q-873 HUB	2
23	596113M	BOLT HH 5/16 X 1/2 GR5 ZP	2
24	730016	GASKET HUB CAP	2
25	730014	NUT SPINDLE 1.25-12 TPI	2
26	730015	COTTER PIN	2
27	730051	NUT WHEEL (913571)	20
28	730045	STUD WHEEL (953033)	20

ILLUSTRATED PARTS LIST (CONT'D)

Parallel Links

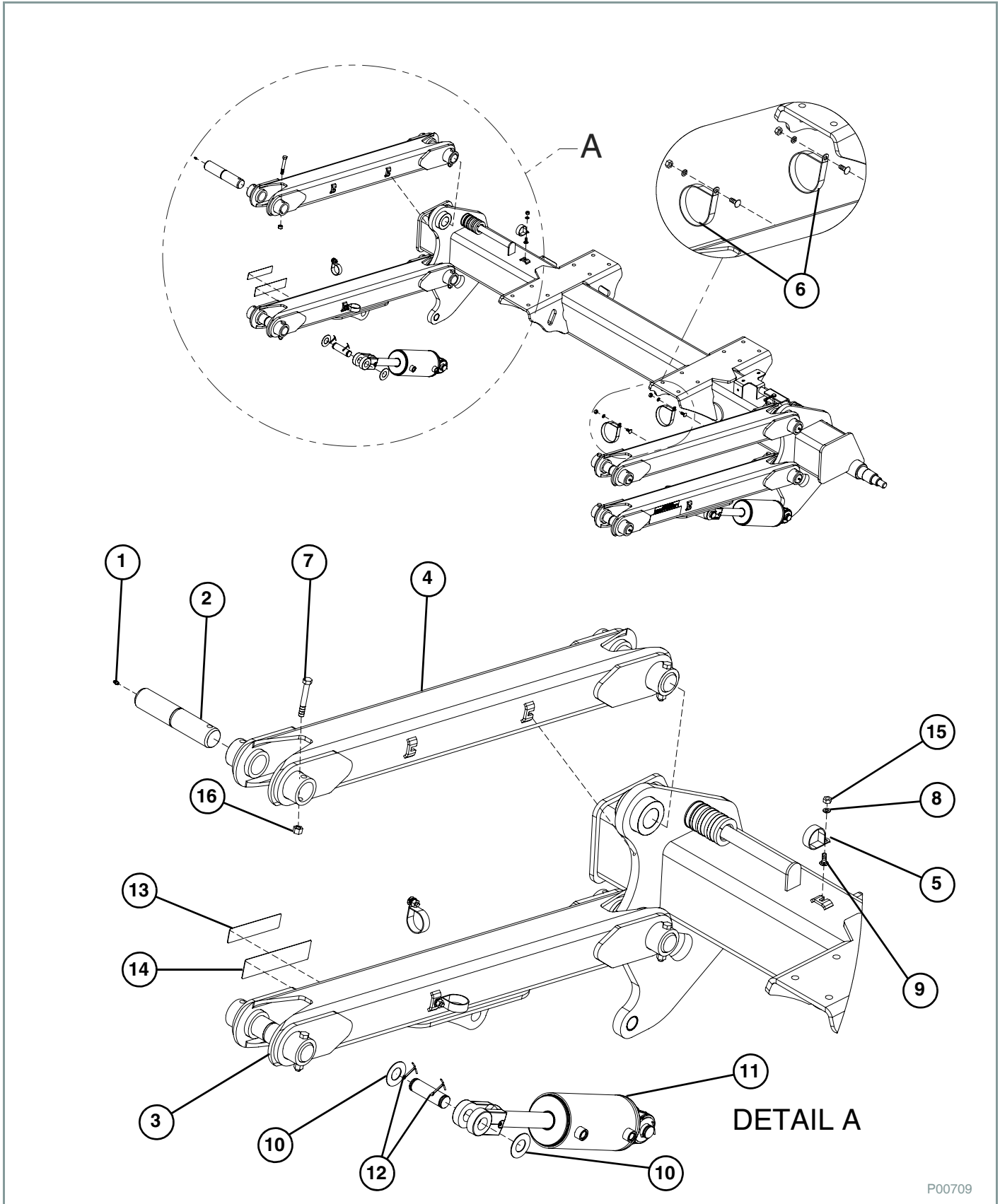

P00709



ILLUSTRATED PARTS LIST (CONT'D)

Parallel Links (Cont'd)

ITEM NO.	PART NO.	DESCRIPTION	QTY.
1	759	ZERK, 1/4-28 STRAIGHT	8
NS	15159	5" CYLINDER STOP	2
2	17823	PIN, TUBE LIFTARM	8
3	22660	WLDMT, LOWER PARALLEL LINK	2
4	22661	WLDMT, UPPER PARALLEL LINK	2
5	540051	P-CLAMP, 2" W/ 3/8" HOLE	2
6	540053	P-CLAMP, 4" W/ 3/8" HOLE	4
NS	590205	3/4" CYLINDER STOP	2
NS	590206	1" CYLINDER STOP	2
NS	590207	1-1/4" CYLINDER STOP	2
NS	590208	1-1/2" CYLINDER STOP	2
7	596157M	BOLT, HH 1/2X3-1/2 GR5 MAGNI	8
8	596250M	LOCKWASHER 3/8 MAGNI	6
9	596592M	BOLT, CARR., 3/8-16 X 1" MAGNI	6
10	596744M	BUSHING, MACHINED, 1-1/4 ID	8
11	620078	CYLINDER 4.75 X 6-150 M LIFT	2
NS	720001	PIN, SNAP, 5/16	2
12	596746M	ROLL PIN 5MM	8
13	800107	DECAL, WARNING-AVOID CRUSHING	2
14	800110	DECAL, AMBER REFLECTOR	2
15	596213M	NUT, HEX 3/8-16 MAGNI	6
16	596239M	NUT, CENTERLOCK, 1/2-13 MAGNI	8

ILLUSTRATED PARTS LIST (CONT'D)

Tire And Rim



P00785

ITEM NO.	PART NO.	DESCRIPTION	TIRE PRESSURE	QTY.
8010N				
1	700024	13.6X38 TIRE/WHEEL SILVER L	42 PSI (289 KPA)	1
	700025	13.6X38 TIRE/WHEEL SILVER R		1
	700026	13.6X38 TIRE/WHEEL YELLOW L		1
	700027	3.6X38 TIRE/WHEEL YELLOW R		1
8013N				
2	700008	320/90R46 TIRE/WHEEL SILVER L	52 PSI (358 KPA)	1
	700009	320/90R46 TIRE/WHEEL SILVER R		1
	700010	320/90R46 TIRE/WHEEL YELLOW L		1
	700011	320/90R46 TIRE/WHEEL YELLOW R		1
8013N				
3	700000	380/90R46 TIRE/WHEEL SILVER L	35 PSI (241 KPA)	1
	700001	380/90R46 TIRE/WHEEL SILVER R		1
	700002	380/90R46 TIRE/WHEEL YELLOW L		1
	700003	380/90R46 TIRE/WHEEL YELLOW R		1



ILLUSTRATED PARTS LIST (CONT'D)

Center Section Assembly

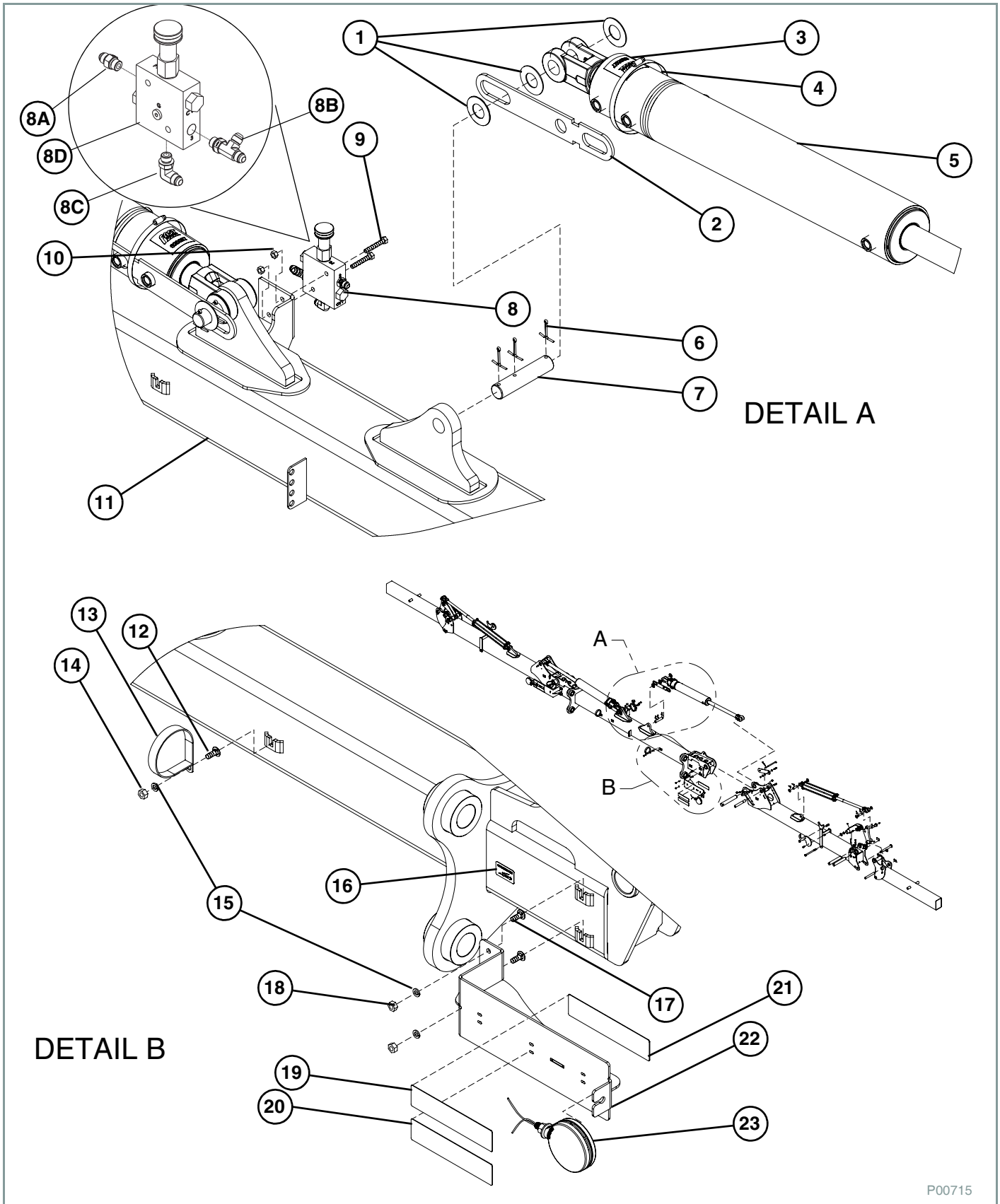

P00715

ILLUSTRATED PARTS LIST (CONT'D)
Center Section Assembly (Cont'd)

ITEM NO.	PART NO.	DESCRIPTION	QTY.
1	596744M	BUSHING, MACHINED, 1-1/4 ID	4
2	15857	PLATE, CYLINDER ANTI ROTATE	2
3	820027	DECAL	2
4	540021	CLAMP, 4 1/8 - 7"	2
5	620027	CYLINDER	2
6	730033	COTTER PIN	6
7	15859	ANTI ROTATE PIN	2
8	90SA8300DPBA	DOWN PRESS. BLOCK ASSY	1
8A	610010	JIC #6 TO ORING #6	1
8B	610074	ORING #6 RUN TEE	1
8C	610078	JIC #6 TO #6 ORING 90°	1
8D	630038	DOWN PRESSURE VALVE	1
9	596117M	BOLT, HH 5/16-18X2 GR5 MAGNI	2
10	596236M	NUT, CENTERLOCK, 5/16-18 MAGNI	2
11	22931	WLDMT, CENTER SECTION	1
12	596592M	BOLT, CARR., 3/8-16 X 1" MAGNI	2
13	540053	P-CLAMP, 4" W/3/8" HOLE	2
14	596213M	NUT, HEX 3/8-16 MAGNI	2
15	596250M	LOCKWASHER 3/8 MAGNI	6
16	800014	DECAL, GREASE PIVOT POINTS	4
17	596592M	BOLT, CARR., 3/8-16 X 1" MAGNI	4
18	596213M	NUT, HEX 3/8-16 MAGNI	4
19	800109	DECAL, RED REFLECTOR	2
20	800111	DECAL, ORANGE REFLECTOR	2
21	800110	DECAL, AMBER REFLECTOR	2
22	22945	WLDMT, LIGHT MOUNT BRACKET	2
23	740024	LIGHT, AMBER, PED. MOUNT	2

ILLUSTRATED PARTS LIST (CONT'D)

Inner Wing Assembly (Left And Right)

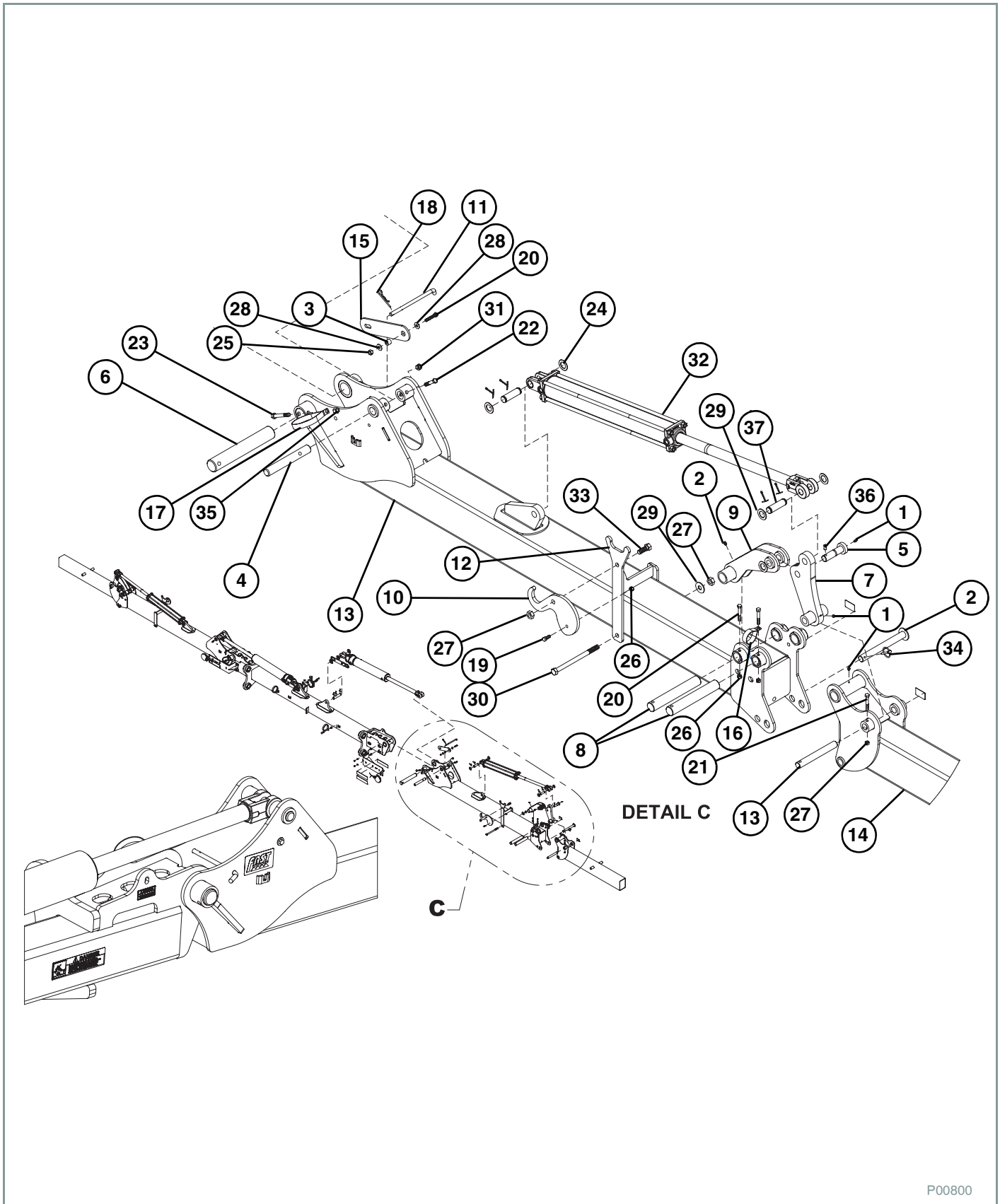

P00800

ILLUSTRATED PARTS LIST (CONT'D)
Inner Wing Assembly (Left And Right) (Cont'd)

ITEM NO.	PART NO.	DESCRIPTION	QTY.
1	759	ZERK, 1/4-28 STRAIGHT	6
2	8339	FLIP WING LOCKING PIN	2
3	15566	SPACER, HOSE BRACKET	2
4	17026	PIN, DOWN PRESSURE	2
5	17060	WLDMT, 1" PIN	2
6	17063	PIN, MAIN WING	2
7	17076	WLDMT, FLIP CYL LINK	2
8	17079	PIN, FLIP BASE	4
9	17080	WLDMT, FLIP LINKAGE	2
10	17143	LATCH, OVERCENTER, 8300	2
11	17808	PIN, WING LOCK	2
12	17887	MOUNT, OVERCENTER LATCH	2
13	22932	WLDMT, WING, COULTER 11 & 15	2
14	22933	WLDMT, FLIP WING 15 COULTER	2
15	22944	PLATE, WING LATCH	2
16	540051	P-CLAMP, 2" W/3/8" HOLE	2
17	540054	P-CLAMP, 4" W/1/2" HOLE	2
18	590017	PIN, HITCH, 1/8 X 3-1/8" ZP	2
19	596128M	BOLT, HH 3/8-16 X 1 GR5 MAGNI	2
20	596130M	BOLT, HH 3/8-16 X 2 MAGNI	2
21	596131M	BOLT, HH 3/8-16X2-1/2 GR5 MAGNI	6
22	596143M	BOLT, HH 7/16X2-1/2 GR5 MAGNI	2
23	596157M	BOLT, HH 1/2X3-1/2 GR5 MAGNI	2
24	596179M	BUSHING, MACHINED 1" X 14GA MAGNI	10
25	596213M	NUT, HEX 3/8-16 MAGNI	8
26	596237M	NUT, CENTERLOCK 3/8 MAGNI	8
27	596240M	NUT, CENTERLOCK, 5/8-11 MAGNI	4
28	596258M	WASHER, FLAT 3/8 MAGNI	4
29	596261M	WASHER, FLAT 5/8 MAGNI	2
30	596477M	BOLT, HH 5/8 X 9 GR5 MAGNI	2
31	596625M	NUT, TOPLOCK 7/16-14 MAGNI	2
32	620004	CYL, 3X24, DUAL ACTING, 12"	2
33	710005	LYNCH PIN, 1/4 X 1-3/4" ZP	2
34	596172M	BOLT, HH 5/8-11X1-3/4 GR5 MAGNI	2
35	596239M	NUT, CENTERLOCK, 1/2-13 MAGNI	2
36	707	PIN SPRING 3/8 X 2	2
37	620002	PIN	2

ILLUSTRATED PARTS LIST (CONT'D)

Gauge Wheel Assembly

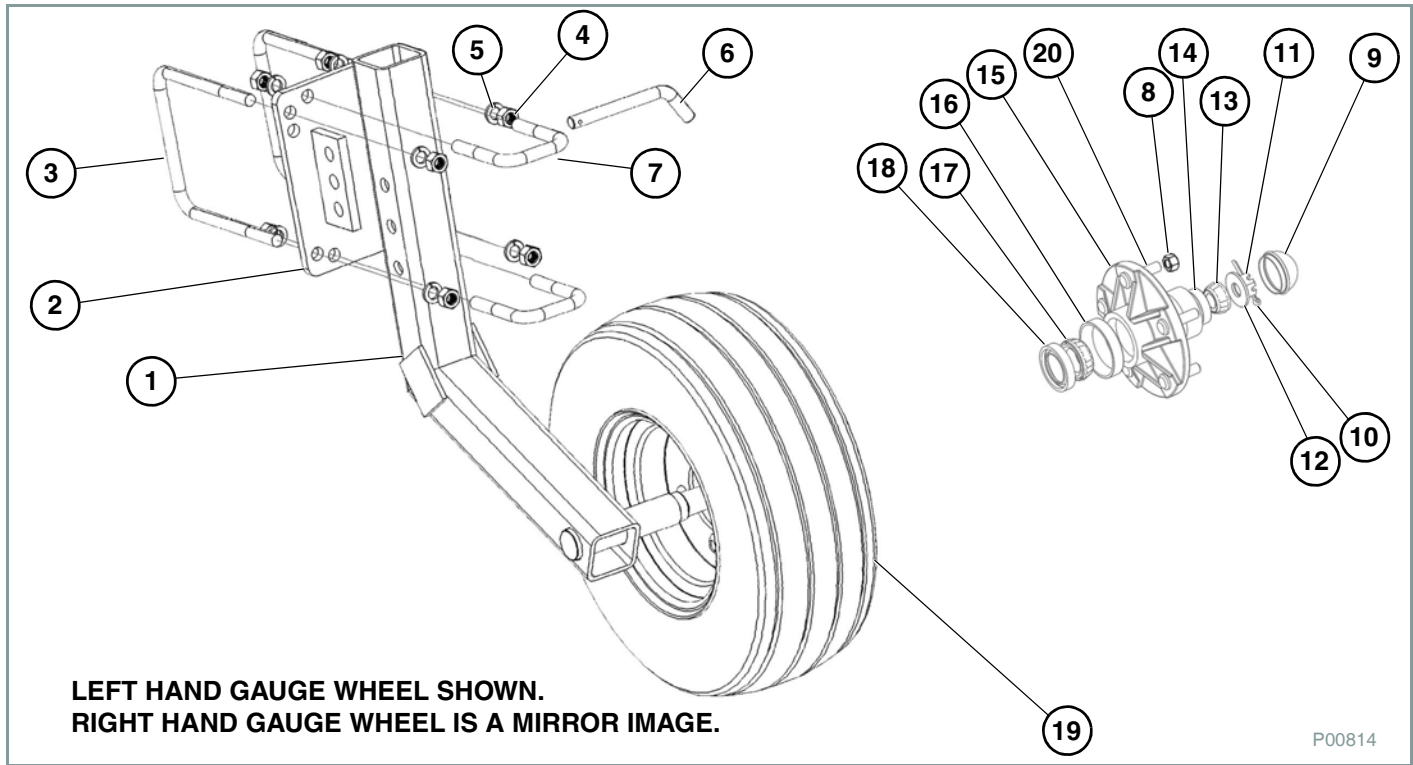

ITEM NO.	PART NO.	DESCRIPTION	QTY.
1	8335	LEFT HAND GAUGE WHEEL WELD	2
	8334	RIGHT HAND GAUGE WHEEL WELD (NOT SHOWN)	2
NS	730065	SPINDLE ONLY	NS
2	8365	LEFT HAND MOUNTING BRACKET	2
	8328	RIGHT HAND MOUNTING BRACKET (NOT SHOWN)	2
3	59104	U-BOLT 7 X 5 X 5/8" ZP	8
4	596216M	NUT HH 5/8" ZP	32
5	596253M	WASHER LOCK 5/8" ZP	32
6	1056	PIN LOCK	4
7	596572M	U-BOLT 3 X 3 X 5/8" ZP	8
8	730030	NUT, STUD	5
9	730044	CAP, HUB	1
10	730033	PIN, COTTER	1
11	730035	NUT CASTLE	1
12	730034	WASHER SPINDLE	1
13	730036	BEARING OUTER	1
14	NI910258	CUP OUTER	1
15	730026	HUB 5 BOLT W CUPS	1
16	NI910257	CUP INNER	1
17	730032	BEARING INNER	1
18	730031	SEAL HUB	1
19	700023	TIRE/WHEEL 20.5	4
20	730030	STUD 1/2 X 20 NFINE THREAD ZP	20
NS	590017	PIN HAIR PIN COTTER (FOR ITEM 6)	4



ILLUSTRATED PARTS LIST (CONT'D)

FAST Coulter Assembly

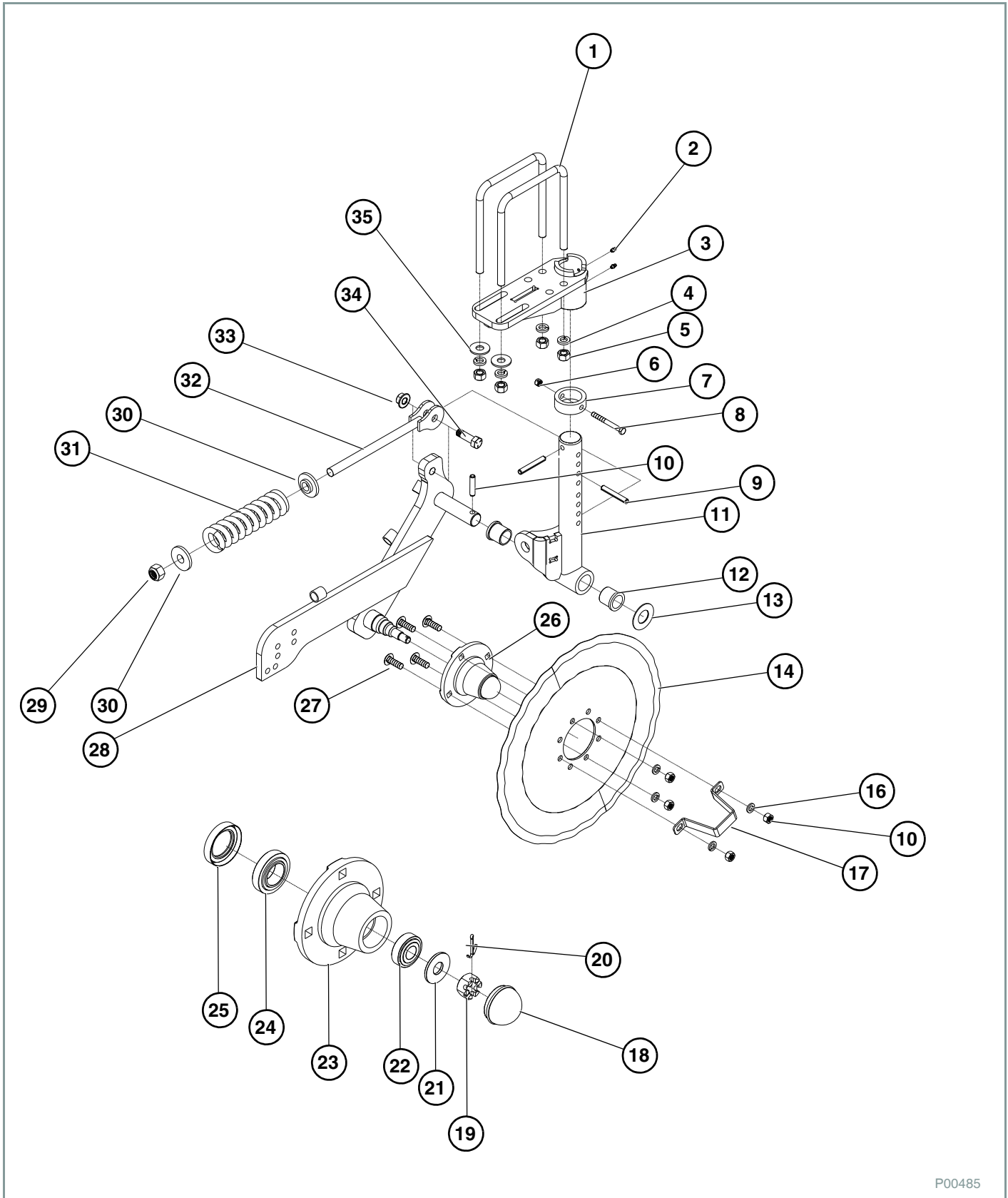

P00485

ILLUSTRATED PARTS LIST (CONT'D)
FAST Coultter Assembly (Cont'd)

ITEM NO.	PART NO.	DESCRIPTION	QTY.
1	590108	U-BOLT, 7 X 7 X 5/8, 7 X 7 BAR	AR
NS	590177	U-BOLT, 7 X 5 X 5/8, 5 X 7 BAR	AR
2	759	ZERK,GREASE 1/4028TPI	2
3	17225	COULTER MOUNT	1
4	596253M	WASHER LOCK 5/8"	4
5	596216M	NUT, HEX HEAD 5/8"	4
6	596237M	NUT, HEX HEAD 5/8" CENTER LOCK	1
7	17209	COLLAR	1
8	596133M	BOLT, HEX HEAD 3/8 x 3-1/2 GRADE 5	1
9	596739M	PIN, ROLL 7/16 x 3	2
10	596740M	PIN, ROLL 7/16 x 2	1
11	17240	2" SHANK WELDMENT	1
12	530328	FLANGED BUSHING	2
13	596744M	WASHER 14 GA x 1-1/4"	1
14	750014	COULTER BLADE	1
15	17214	HUB CAP RETAINER BRACKET	1
16	596215M	NUT, HEX HEAD 1/2"	4
17	596251M	WASHER LOCK 1/2"	4
18	730044	HUB DUST CAP	1
19	730088	NUT, CASTLE 5/8"	1
20	730033	PIN COTTER	1
21	730034	WASHER, HUB	1
22	730036	BEARING	1
23	NIN285001	HUB 4 BOLT	1
24	730032	BEARING	1
25	730031	SEAL, GREASE	1
26	730095	HUB COMPLETE (incl. items 18 thru 25)	1
27	596620M	BOLT, CARRIAGE 1/2 x 1-1/2"	4
28	17205	COULTER MAIN ARM	1
29	596743M	NUT, HEX HEAD 3/4" NYLOCK	1
30	17208	WASHER, SPRING END	2
31	590123	COULTER SPRING	1
32	17210	SPRING LEVER	1
33	596742M	NUT, HEX HEAD 5/8" TOP LOCK	1
34	590260	BOLT, HEX HEAD 5/8 x 2 GRADE 5, SPECIAL	1
35	596261M	WASHER FLAT 5/8"	2
NS	17248L	OFFSET COULTER MOUNT LEFT	AR
NS	17248R	OFFSET COULTER MOUNT RIGHT	AR
NS	17244	COULTER MOUNT TOP PLATE (WHEN U-BOLTS WILL NOT WORK)	AR
NS	596477M	BOLT HEX HEAD 5/8" X 9" GR5	AR

ILLUSTRATED PARTS LIST (CONT'D)

Coulter Knife Assembly

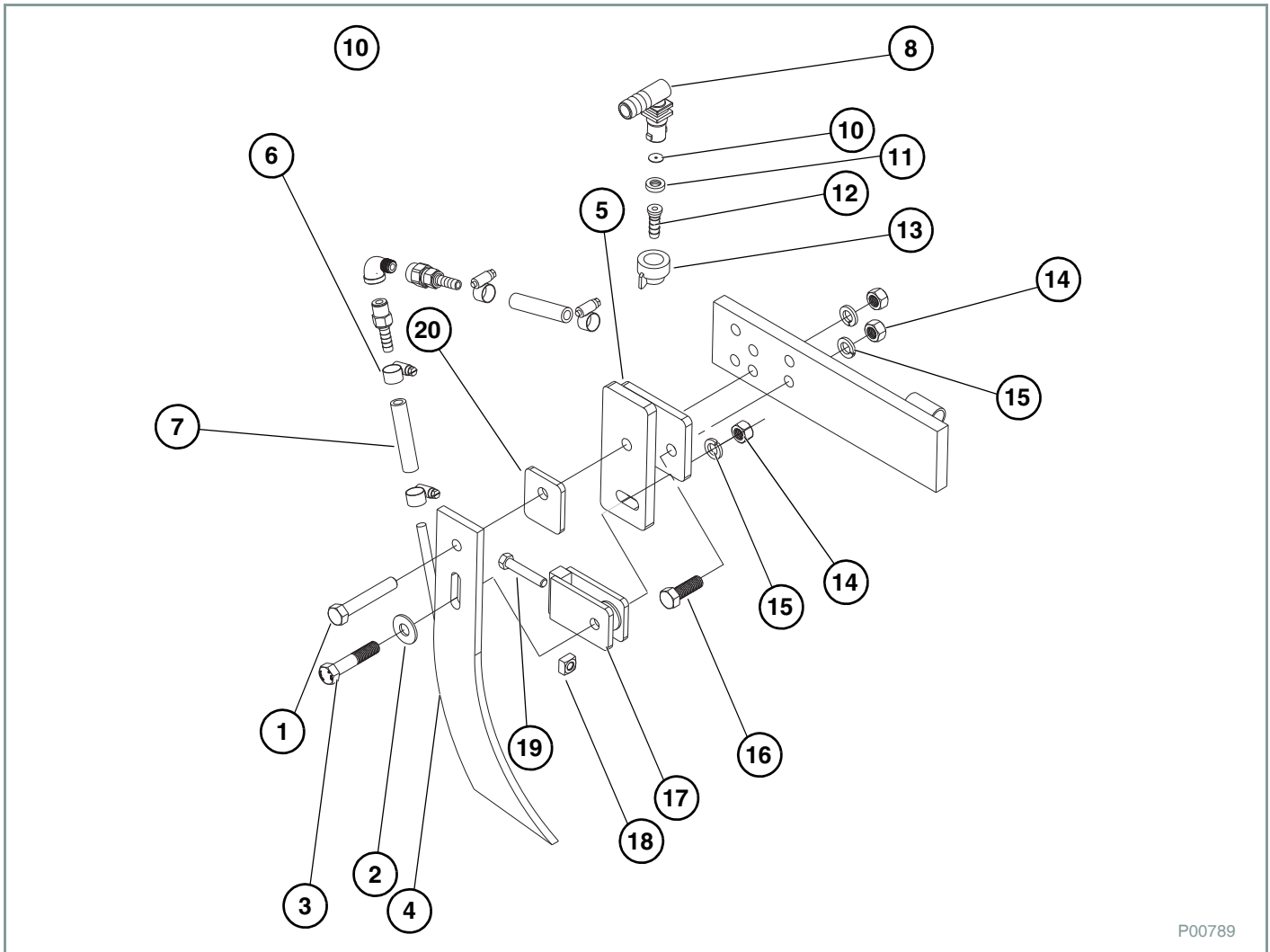

P00789



ILLUSTRATED PARTS LIST (CONT'D)

Coulter Knife Assembly (Cont'd)

ITEM NO.	PART NO.	DESCRIPTION	QTY.
1	CLFBH0813	CAP SCREW 1/2 IN. X 3-1/4 IN.	1
2	596260M	WASHER 1/2 IN. X 1-1/2 IN. X 0.105 IN.	2
3	596155M	BOLT HEX HEAD 1/2 IN. X 2-1/2 IN. GRADE 5	1
4	750003	COLTER KNIFE	1
5	17915	KNIFE MOUNT	1
6	540011	CLAMP 3/8 IN.	2
7	510020	BULK HOSE 3/8 IN., AG EPDM SPRAYER HOSE	AR
8	520062	ELBOW FITTING 3/4 IN., ELBOW-HOSE 2# CHECK	AR
NS	520063	HOSE FITTING 3/4 IN., TEE HOSE BARB 2# CHECK	AR
10*	TJCP4916-XXX	PLATE ORIFICE; REFER TO OM FOR ORIFICE SELECTION GUIDE	1
11	590029	SEALING WASHER ORIFICE DISC	1
12	590077	HOSE FITTING SHANK 38617-311-750HYD	1
13	590076	HOSE FITTING CP256071NY	1
14	C LFNH08	NUT HEX 1/2"	3
15	CLEWL08	LOCK WASHER 1/2 IN.	3
16	CLFBH0807	CAP SCREW 1/2 IN. X 1-3/4 IN.	1
17	17910	KNIFE ADJUSTER	1
18	596762M	NUT 3/8 IN. SQUARE NUT	1
19	596660M	CAP SCREW 3/8 IN. X 2 IN. FULL THREAD	1
20	17909	COULTER SHIM PLATE	1
NS	17920	KNIFE SHIM 14 GAUGE	AR
NS	17921	KNIFE SHIM 10 GAUGE	AR
NS	17922	KNIFE SHIM 7 GA+A1:H67UGE	AR

*-THE XXX IS ORIFICE SIZE.

ILLUSTRATED PARTS LIST (CONT'D)

Injector Arm Assembly

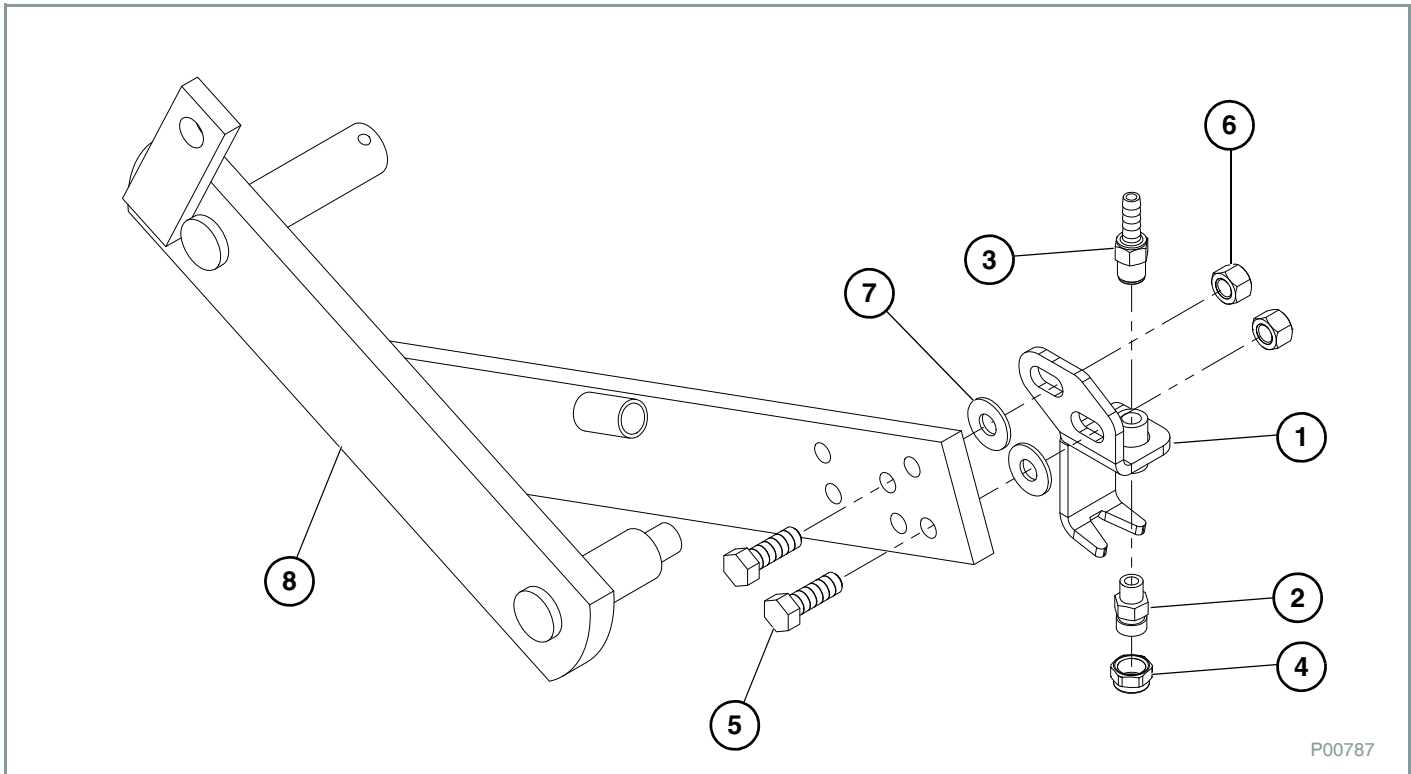

P00787

ITEM NO.	PART NO.	DESCRIPTION	QTY.
1	15247	INJECTION MOUNT	1
2	520015	1/4" S.S. NOZZLE BODY	1
3	530247	FITTING, 1/4" PIPE TO 3/8" HOSE, SS	1
4	520060	1/4" SS TEEJECT TIP NUT	1
5	596153M	BOLT, HH 1/2-13X1-1/2 GR5 MAGNI	2
6	596239M	NUT, CENTERLOCK, 1/2-13 MAGNI	2
7	596260M	WASHER, FLAT 1/2 MAGNI	2
8	NCIK347-4	SWING ARM CLYMER COULTER	1



ILLUSTRATED PARTS LIST (CONT'D)

1050 - 1350 Tank Assemblies

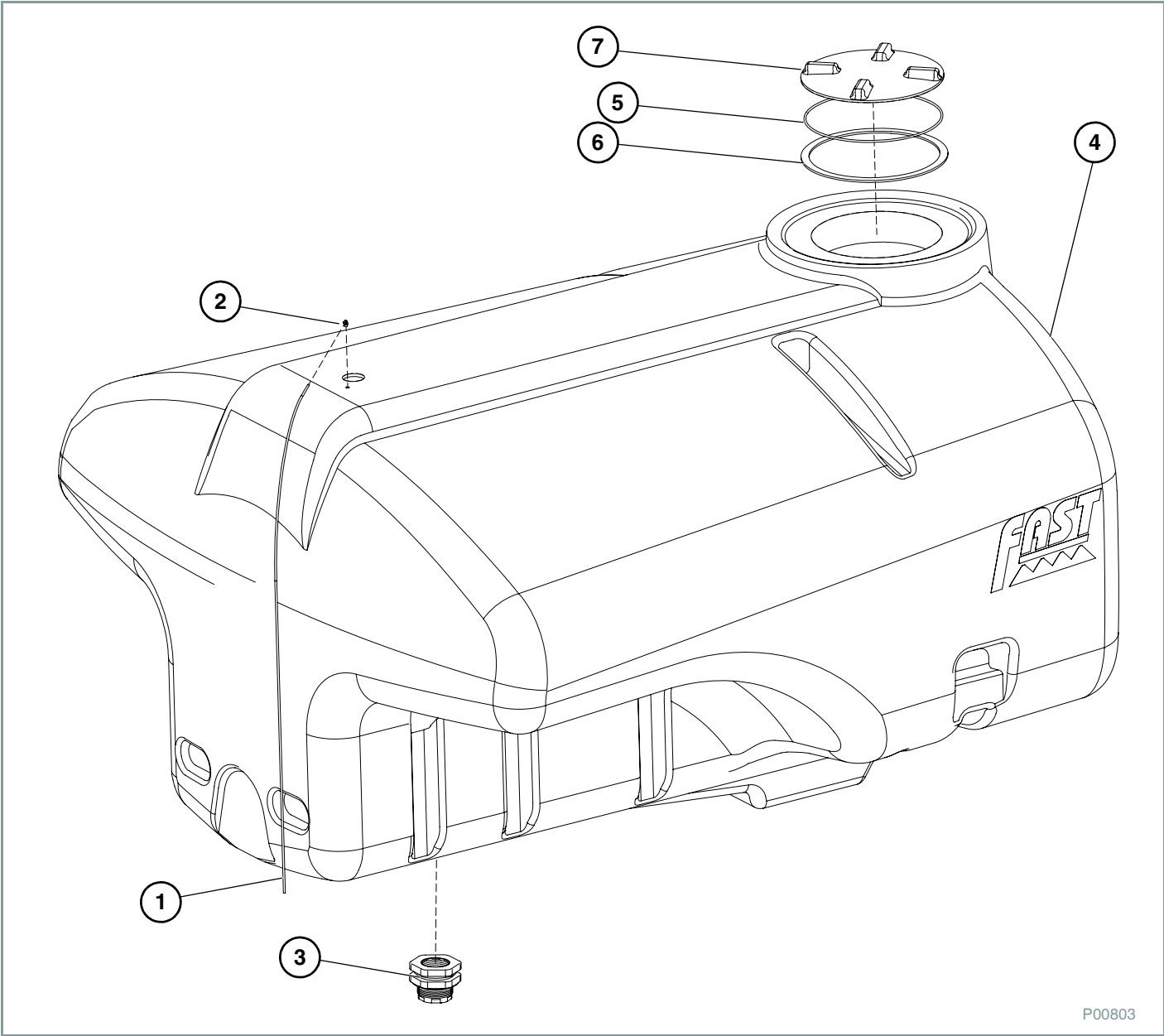

P00803



ILLUSTRATED PARTS LIST (CONT'D)

1050 - 1350 Tank Assemblies (Cont'd)

ITEM NO.	PART NO.	DESCRIPTION	QTY.
1	510023	TUBE, PUMP BURP, 1/4"	AR
2	530004	CONNECTOR, 90° 1/4" TUBE X 1/4" NPT	1
3	530411	BULKHEAD FITTING 2" FULL PORT	1
4	570131	TANK, 1050 GALLON WHITE	1
	570127	TANK, 1050 GALLON YELLOW	
	570133	TANK, 1350 GALLON WHITE	
	570129	TANK, 1350 GALLON YELLOW	
5	570120	O-RING	1
6	570121	FLAT GASKET	1
7	570123	NON VENTED TANK LID	1



ILLUSTRATED PARTS LIST (CONT'D)

Fill Valve To Tank To Pump Plumbing

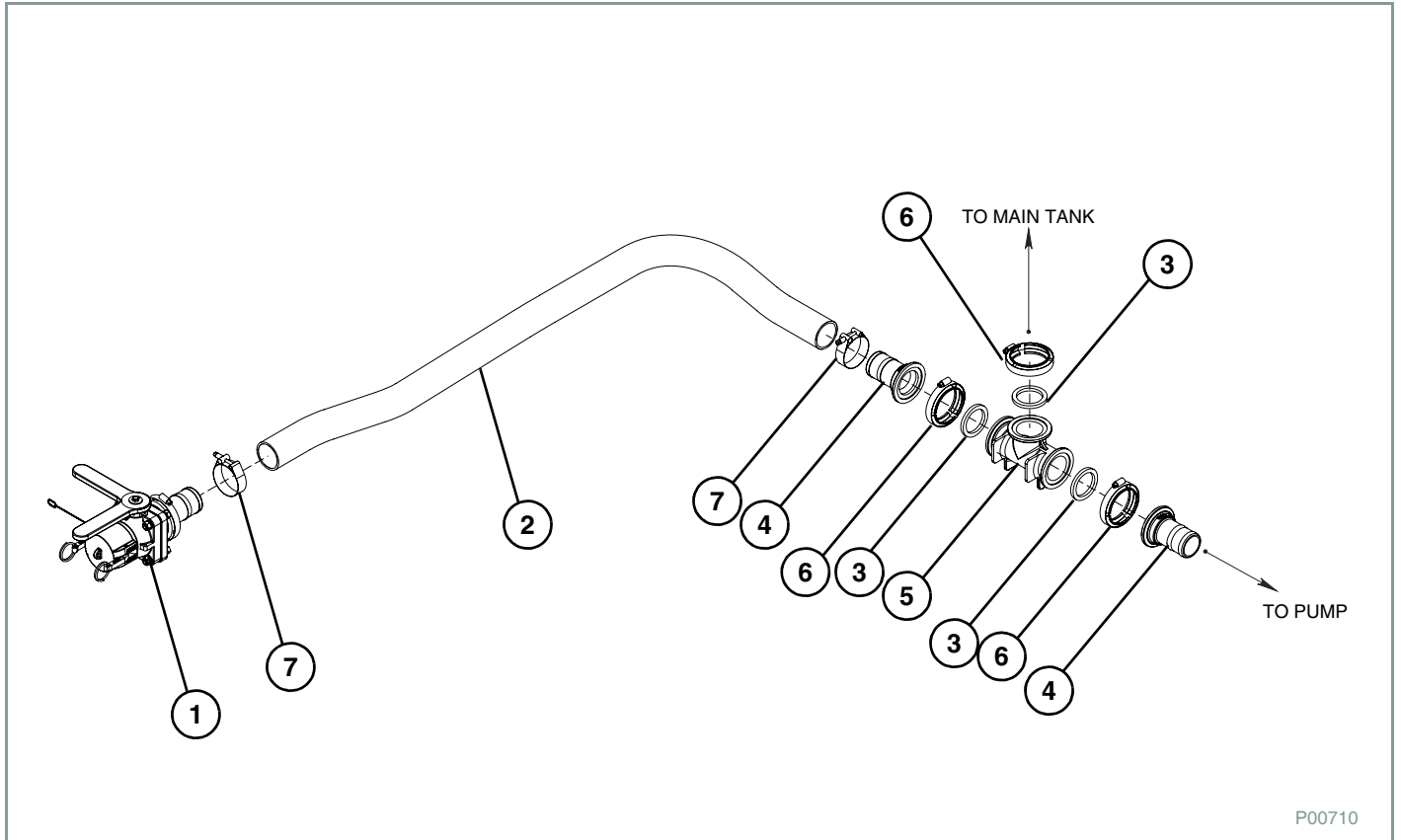

P00710

ITEM NO.	PART NO.	DESCRIPTION	QTY.
1	90SAMTQF	MAIN TANK QUICK FILL 2"	1
2	510003	HOSE, 2" FERTILIZER	1
3	530019	GASKET, 2" EPDM	3
4	530103	2" FP FLANGE X 2" HBRB	2
5	530110	2" MANIFOLD TEE	1
6	540002	CLAMP, WORM SCREW 2"	3
7	540007	HOSE CLAMP, 2" T-BOLT	2

ILLUSTRATED PARTS LIST (CONT'D)

Ball Valve To Tank To Pump Plumbing Supporting Hardware

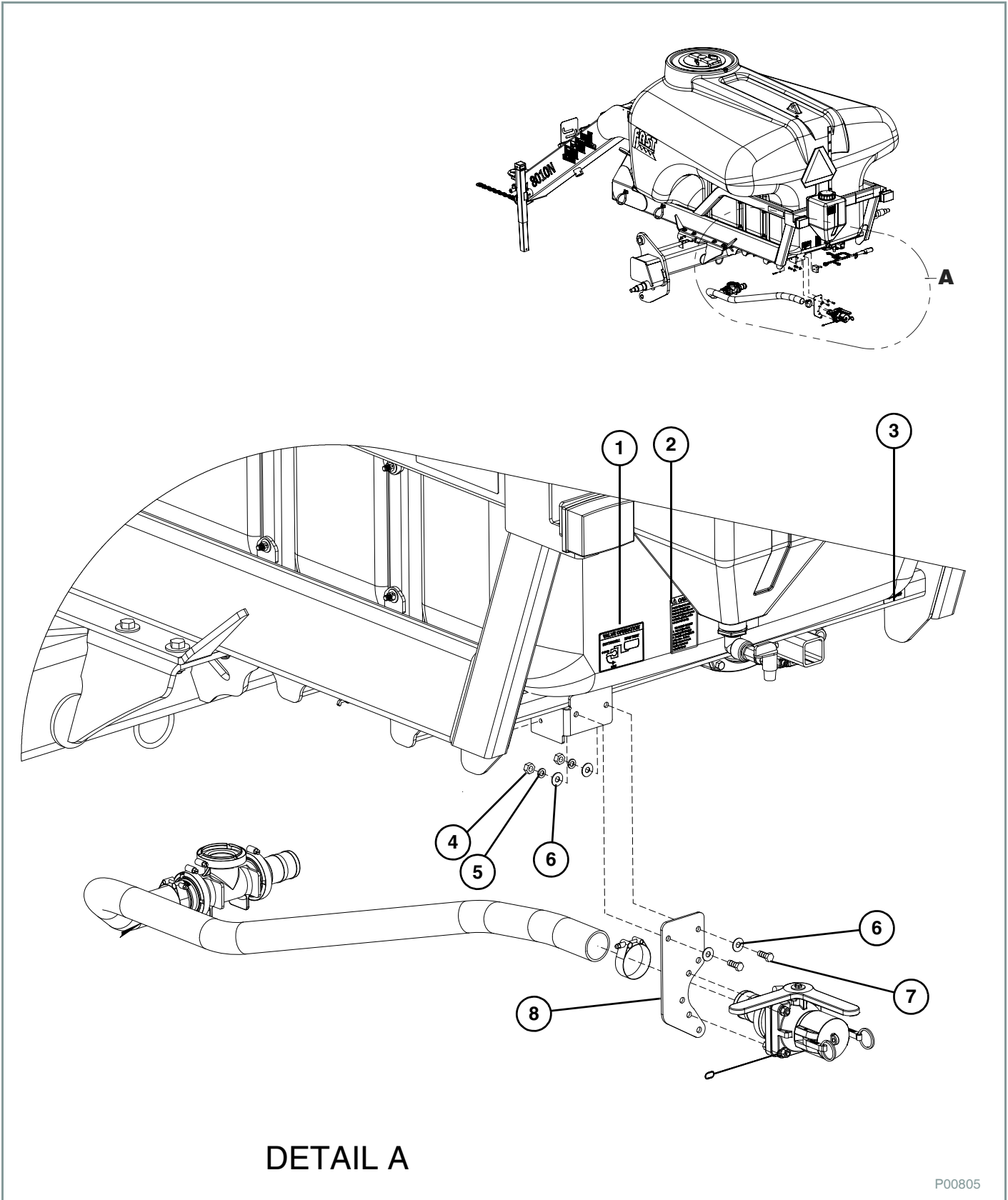



ILLUSTRATED PARTS LIST (CONT'D)

Ball Valve To Tank To Pump Plumbing Supporting Hardware (Cont'd)

ITEM NO.	PART NO.	DESCRIPTION	QTY.
1	800017	DECAL, MAIN TANK VALVE OPERATION	1
2	800101	DECAL, CAUTION-AG CHEMICAL	2
3	800057	DECAL, US PATENT 7585000	1
4	596213M	NUT HEX HEAD 3/8	2
5	596250M	LOCKWASHER 3/8 MAGNI	12
6	596258M	WASHER, FLAT 3/8 MAGNI	14
7	596128M	BOLT, HH 3/8-16 X 1 GR5 MAGNI	6
8	22253	PLATE, QUICK FILL VALVE MOUNT	1

ILLUSTRATED PARTS LIST (CONT'D)

Tank Tee To Ball Valve To Pressure Gauge

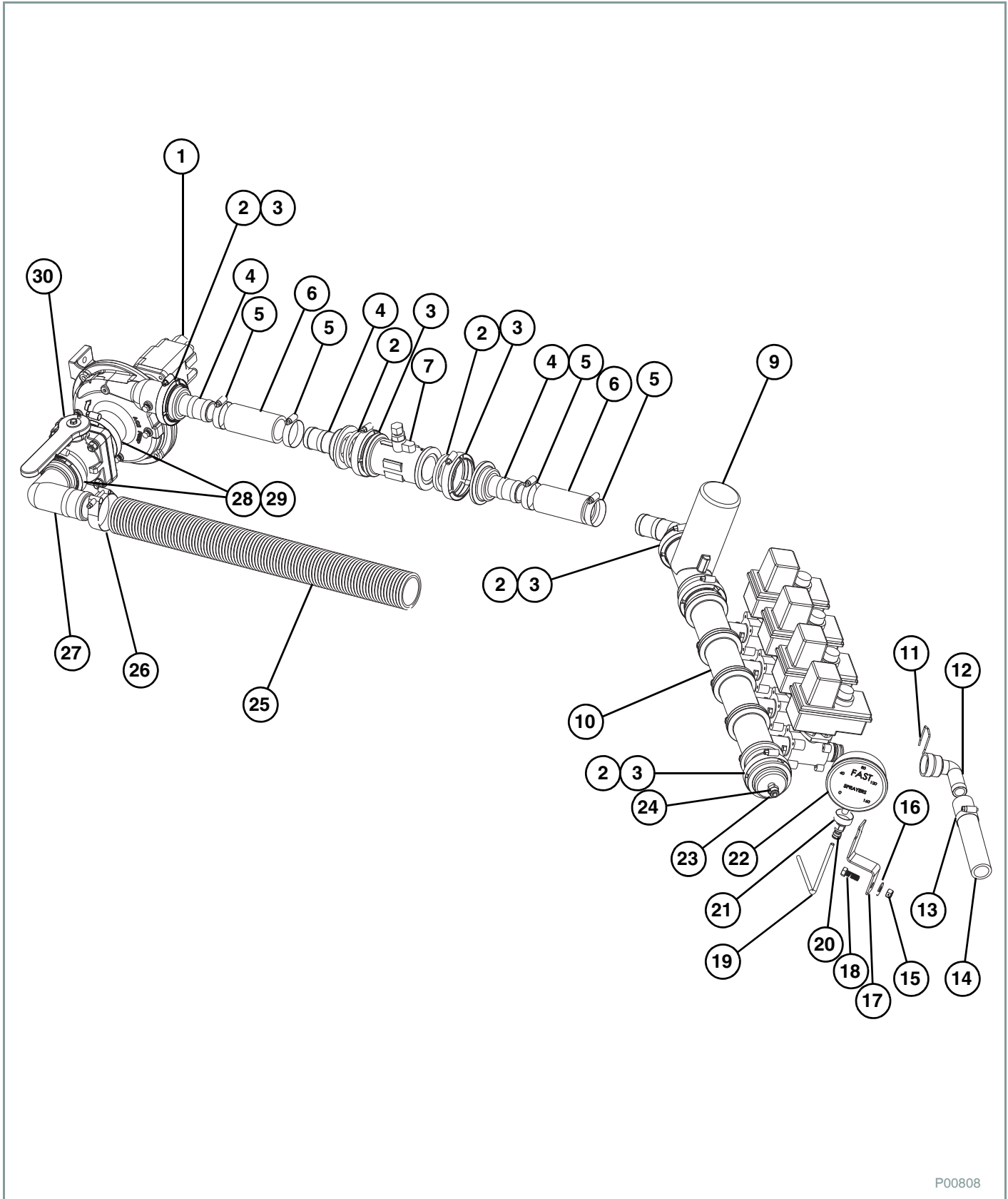

P00808



ILLUSTRATED PARTS LIST (CONT'D)

Tank Tee To Ball Valve To Pressure Gauge (Cont'd)

ITEM NO.	PART NO.	DESCRIPTION	QTY.
1	550000	PUMP 150F-206	1
2	530014	GASKET FLANGE 2" STD	8
3	540001	CLAMP FLANGE 2" STD	8
4	530079	MANIFOLD HOSE BARB 1.5"	1
5	540016	CLAMP 1.5"	4
6	510014	HOSE EDPM 1.5"	AR
7	631804	FLOW METER 60P	1
8	530423	MANIFOLD HOSE BARB 1.5" 45 DEGREE	1
9	631805	MOTORIZED CONTROL VALVE	1
10	500025	SECTION CONTROL VALVES (4 SHOWN)	AR
11	530193	CLIP HOLDON	AR
12	530190	ELBOW OUTLET 90 DEGREE	AR
13	510016	HOSE EDPM 1"	AR
14	540014	CLAMP 1"	AR
15	596237M	NUT HEX HEAD 3/8	1
16	596258M	WASHER FLAT 3/8"	1
17	22706	HOLDER GAUGE	1
18	596128M	BOLT, HEX HEAD 3/8 X 1 GR5	1
19	510023	TUBE 1/4" GAUGE FEED	AR
20	530417	ADAPTER 1/4" TO TO 1/4" FPT	1
21	540013	CLAMP HOSE 3/4"	1
22	790020	GAUGE 0-160 PSI	1
23	530001	ADAPTER 1/4" TUBING TO TO 1/4" MPT	1
24	530094	MANIFOLD CAP X 1/4" FPT	1
25	510003	HOSE 2" FERTILIZER	AR
26	540007	CLAMP T-BOLT	1
27	530104	MANIFOLD ELBOW 2" FP 90 DEGREE	1
28	530019	GASKET FLANGE 2" FP	1
29	540002	CLAMP FLANGE 2" FP	1
30	530327	VALVE STUBBY MANIFOLD 2" FP	1

ILLUSTRATED PARTS LIST (CONT'D)

Toolbar Plumbing

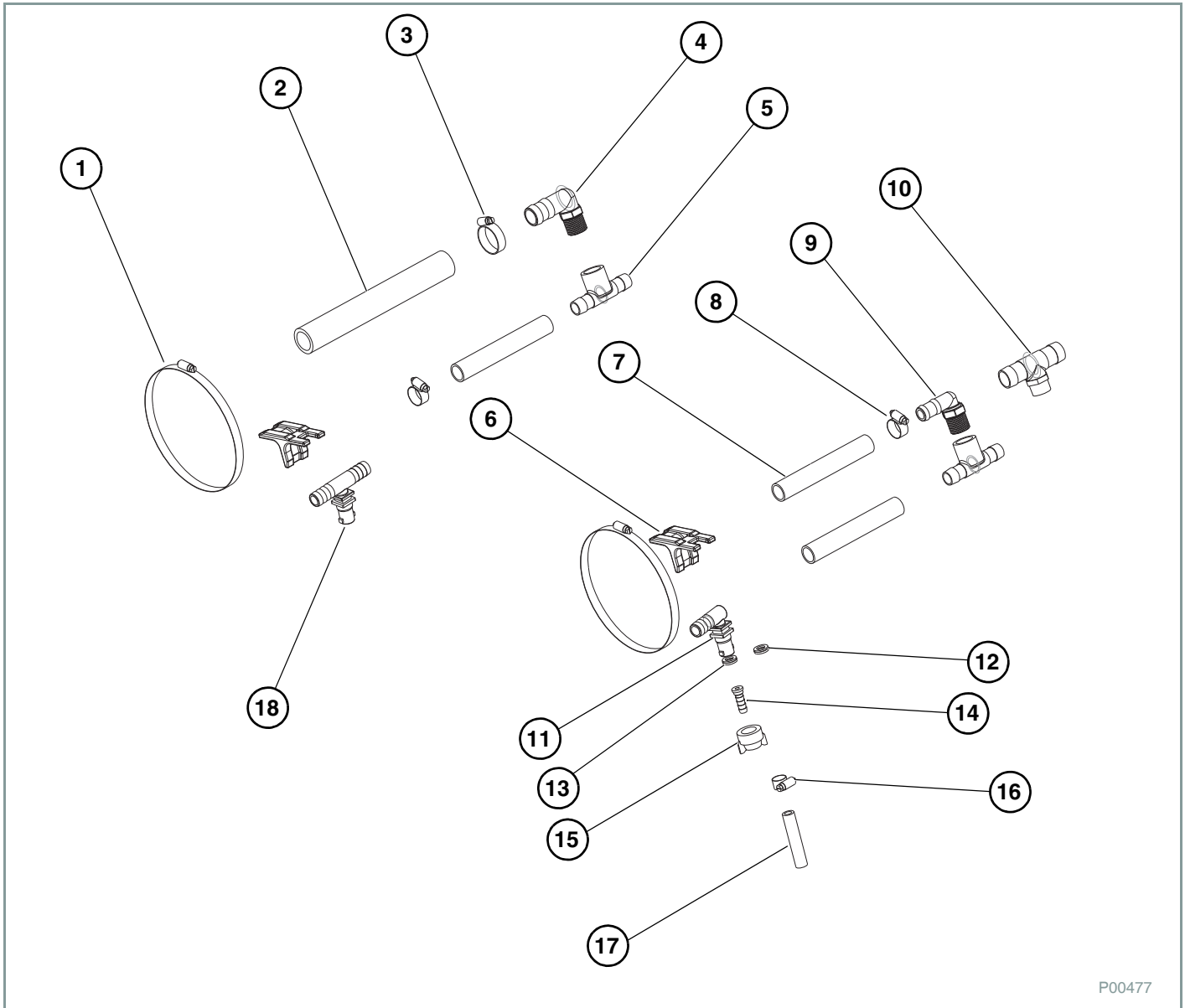

P00477



ILLUSTRATED PARTS LIST (CONT'D)

Toolbar Plumbing (Cont'd)

ITEM NO.	PART NO.	DESCRIPTION	QTY.
1	540050	HOSE CLAMP 7"	AR
2	510016	HOSE 1" EDPM	AR
3	540014	HOSE CLAMP 1"	AR
4	530036	HOSE BARB 90° 3/4" PT X 1" HB	AR
5	530220	TEE 3/4" HOSE BARB X 3/4" FPT	AR
6	590187	MOUNT NOZZLE BODY	AR
7	510019	HOSE 3/4" EDPM	AR
8	540013	HOSE CLAMP 3/4"	AR
9	510011	HOSE BARB 90° 3/4" PT X 3/4" HB	AR
10*	530181	3/4" MPT X 3/4" HOSE BARB TEE	AR
11**	520062	NOZZLE SINGLE FOR INJECTION	AR
12**	520016	GASKET FOR INJECTION	AR
13*	590029	GASKET (ORFICE) FOR KNIFE	AR
14*	590076	CAP FOR BARB	AR
15	590077	CONNECTOR, HOSE BARB	AR
16	540011	HOSE CLAMP 3/8"	AR
17	510020	HOSE 3/8" EDPM	AR
18**	520063	NOZZLE TEE FOR INJECTION	AR
* - ITEMS 10 AND 13 USED WITH KNIFE ON COULTER			
** - ITEMS 11, 12 AND 18 USED WITH INJECTION ON COULTER			

ILLUSTRATED PARTS LIST (CONT'D)

Ace FMC-150F-HYD-206 & FMC-150FS-HYD-206 Pump

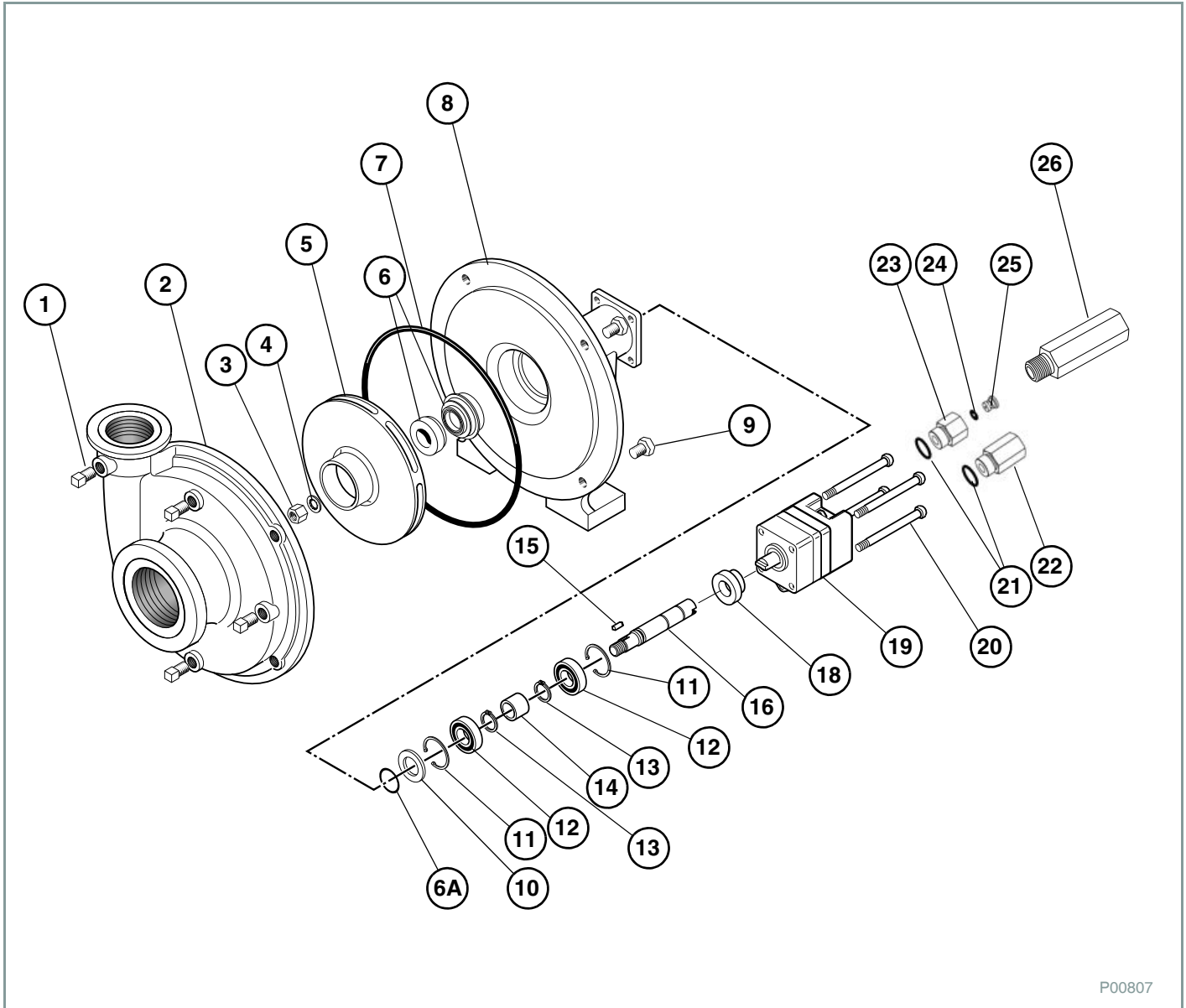

P00807

ILLUSTRATED PARTS LIST (CONT'D)
Ace 205F - 304 Pump (Cont'd)

ITEM NO.	PART NO.	DESCRIPTION	QTY.
1	BAC-53	PIPE PLUG	4
2	BAC-12-150-FLG	VOLUTE, CAST IRON, NPT & FLANGED (FOR 150F MODELS)	1
3	BAC-23-A	NUT, 3/8" NF, CAD PLATED	1
4*	BAC-24-HYD-SS	WASHER, 3/8" STAR, STAINLESS STEEL	1
5	BAC-26-150-P	IMPELLER, VALOX, KEYWAY	1
6*	BAC-7V	SEAL, CARBON/CERAMIC/VITON (INCLUDES 40160 O-RING)	1
6A*	40160	O-RING, SHAFT SEAL	1
7*	BAC-4-150	O-RING, BODY SEAL	1
8	BAC-14-150-HYD	MOUNTING FRAME, CAST IRON (FOR 150F MODELS)	1
9	40950	CAP SCREW, 3/8" NC X 3/4" HEX HEAD	4
10	BAC-54	SLINGER	1
11	BAC-33	SNAP RING, INTERNAL, BAC-14 MOUNTING FRAME	2
12	BAC-37	BALL BEARING, SEALED, BAC-6 SHAFT	2
13	BAC-32	SNAP RING, EXTERNAL, BAC-6 SHAFT	2
14	BAC-32-S	SPACER FOR BAC-6 SHAFT	1
15	BACH-25	KEY, 1/8" X 1/8" X 1/2"	1
16	BAC-6-HYD-SS	SHAFT, 5/8" DIAMETER, KEYWAY AND TANG SLOT, STAINLESS STEEL	1
17	BAC-75-HYD-206	HYDRAULIC MOTOR, 7 GPM (INCLUDES PARTS 18 - 25)	1
18	S200	SEAL SUPPORT SPACER FOR 200 SERIES HYD MOTOR	1
19	BAC-75-HYD-206N	HYDRAULIC MOTOR, 7 GPM (MOTOR ONLY - NO EXTERNAL FITTINGS)	1
20	41255	CAP SCREW, 5/16" N. C. X 3-3/4" SOCKET HEAD (FOR 206N MOTOR)	4
21	41875	O-RING, #8 SAE FITTING	2
22	BAC-78-10X8SAE	REVERSE CHECK VALVE, #8 SAE MALE X 10 SAE FEMALE	1
23	BAC-80-10X8SAE	ADAPTER, RESTRICTOR BODY, #8 SAE MALE X 10 SAE FEMALE	1
24	41448	O-RING, ORIFICE INSERT	1
25	BAC-79-7	ORIFICE, RESTRICTOR INSERT, 0.109 (206N)	1
26	LS-206N	FLOW LIMITING VALVE (206N), #8 SAE MALE X 1/2" NPT FEMALE	1
27*	RK-FMC-150	REPAIR KIT FOR FMC-150 SERIES PUMP	AR
29	RK-BAC-75-HYD-L	REPAIR KIT FOR 200-L SERIES MOTOR	AR

* - Repair Kit (Item 27) contains Items 4, 6, 6A & 7.

ILLUSTRATED PARTS LIST (CONT'D)

Directo Valve® Electric 2-Way Ball Valve Manifold

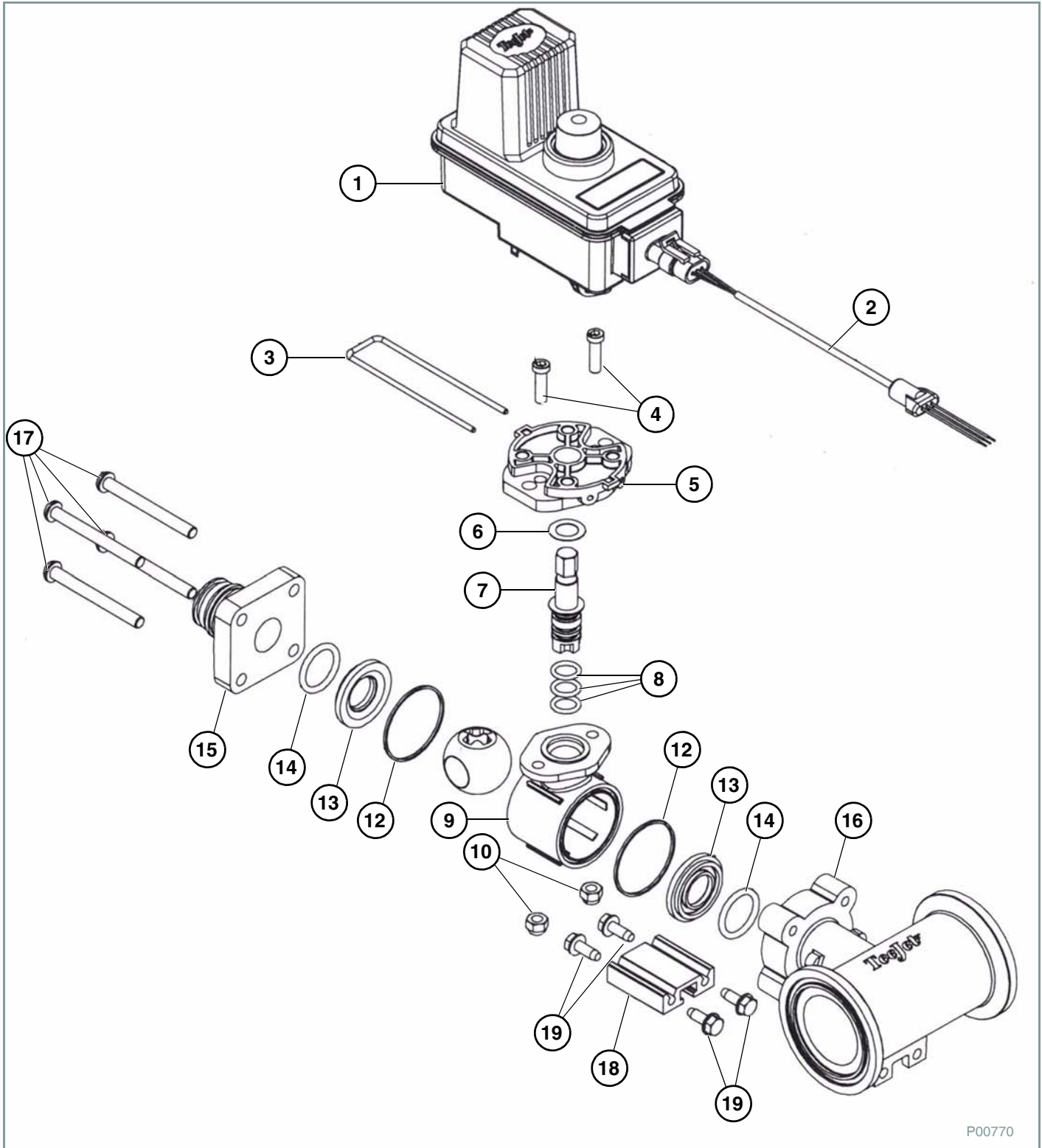

P00770

ILLUSTRATED PARTS LIST (CONT'D)
Directo Valve® Electric 2-Way Ball Valve Manifold (Cont'd)

ITEM NO.	PART NO.	DESCRIPTION	QTY.
1	50515-22CP03	BEC MOTOR, 22-RPM (0.7-SEC),0.3-METER CABLE, POSITIVELY SWITCHED	1
2	98546EC-_	3-WIRE CABLE W/ METRI-PACK TOWER CONNECTION	1
3	CP50517-SSPV	RETAINING CLIP, 304 STAINLESS STEEL	1
4	CP26197-7/8-SS	SOCKET HEAD CAP SCREW, STAINLESS STEEL	2
5	CP5514-99	MOTOR ADAPTER, POLYPROPYLENE (BLACK)	1
6	CP20125-TEF	THRUST WASHER, TEFLON™	1
7	CP56613-SS	STEM, 303 STAINLESS STEEL (FOR POLYPYLENE BALL	1
8	CP7717-M12X2.5-VI	O-RING VITON®	3
9	CP20101-NYB	BODY, NYLON (BLACK) (2-WAY)	1
10	CP38435-1/4-SSNY	ELESTIC LOCKNUT, STAINLESS STEEL	2
11	CP20106-1-PP	BALL, POLYPROPYLENE (WHITE) (2-WAY)	1
12	CP20564-VI	GASKET, VITON®	2
13	CP20103-TEF	SEAL, TEFLON™	2
14	CP7717-2/213-VE	O-RING, VITON™	2
15	CP45514-NYB	END CAP, NYLON (BLACK) (QUICK CONNECT)	1
16	CP45251-PP	75-SERIES TEE BODY, POLYPYLENE (BLACK)	1
17	CP45252-2-3/4-SSPV	SCREW, 1/4 IN.-12 X 2-3/4 IN. PAN HEAD, STAINLESS STEEL	4
18	CP45216-AL	MOUNTING RAIL, ALUMINUM	1
19	CP45259-S	SCREW, M6 X 1 16 MM HEX, STAINLESS STEEL	1
NS	56609-2_-_-	VALVE BODY SUB-ASSY, SPECIFY WIDTH, OUTLET FITTING AND BALL MATERIAL (INCLUDES ITEMS 4 THROUGH 19)	1
NS	AB344AE-KIT	SPARE PARTS KIT (INCLUDES ITEMS 6, 8, 12, 13 AND 14)	1

ILLUSTRATED PARTS LIST (CONT'D)

1-1/2 In. Poly Control Valve Assembly (063-0171-894)

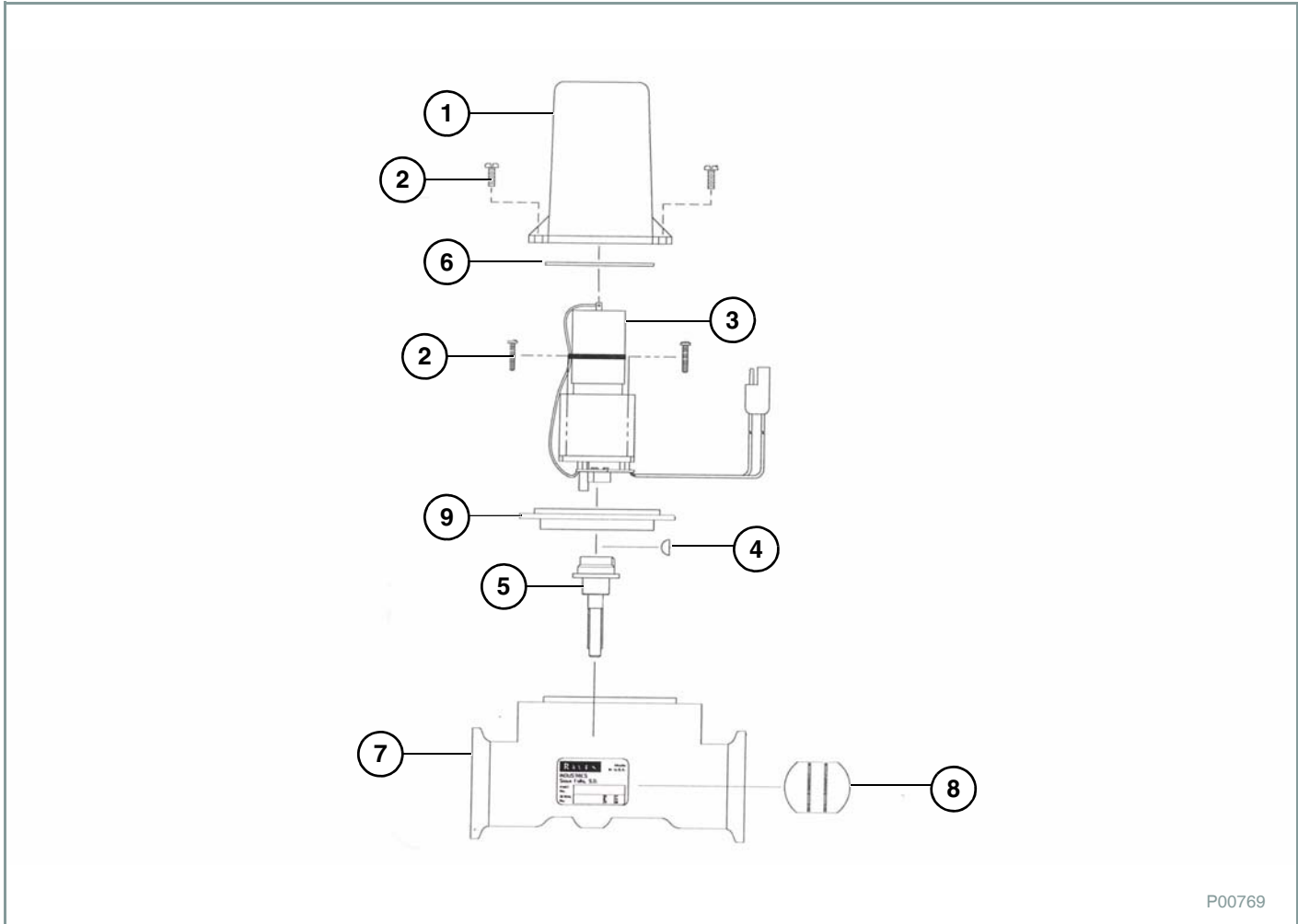

P00769

ITEM NO.	PART NO.	DESCRIPTION	QTY.
1	106-0159-407	VALVE COVER	1
2	321-0000-256	#6-32X3/4" LG.SCREW	4
3	063-0159-409	MOTOR ASSEMBLY	1
4	321-0000-063	WOODRUFF KEY	1
5	063-0171-893	COUPLER SHAFT ASSEMBLY (1-1/2 IN. VALVE)	1
6	219-0000-020	SEAL TETRASEAL	1
7	063-0171-892	VALVE BODY ASSEMBLY (1-1/2 IN. VALVE)	1
8	106-0159-414	BUTTERFLY (1-1/2 IN. VALVE)	1
9	063-0159-457	ISOLATION FLANGE ASSEMBLY	1
NS	117-0159-739	ISO BODY KIT (1-1/2 IN. VALVE)	1
NS	115-0159-415	POLARITY REVERSAL JUMPER	1
NS	222-1001-050	LOCTITE RC-609®	1

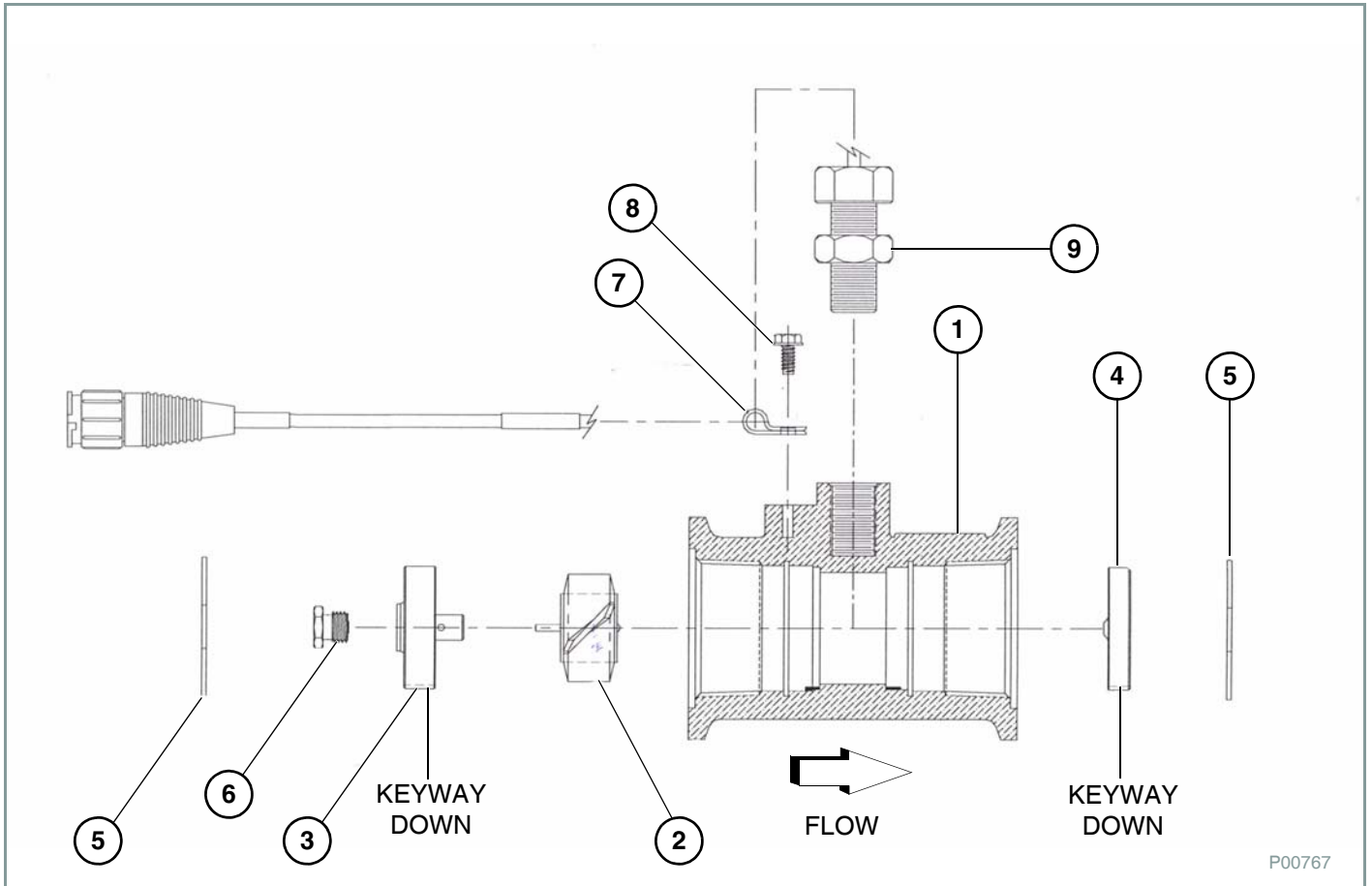
Flowmeter, Raven, RFM60 P Assembly (063-0171-793)

P00767

ITEM NO.	PART NO.	DESCRIPTION	QTY.
1	106-0159-514	BODY, RFM 60 P FLOWMETER	1
2	063-0171-673	ROTOR/MAGNET ASSEMBLY	1
3	063-0171-674	HUB/BEARING ASSY. UPSTREAM	1
4	063-0171-769	HUB ASSEMBLY, DOWNSTREAM	1
5	335-0000-278	RING, RETAINING, INTERNAL	1
6	063-0159-573	STUD BEARING	1
7	435-3002-017	CLAMP, CABLE	1
8	310-0002-137	SCREW, THREAD FORMING	1
9	063-0171-669	SENSO, ASSEMBLY, EXTERNAL	1

ILLUSTRATED PARTS LIST (CONT'D)

Raven SCS440 Console

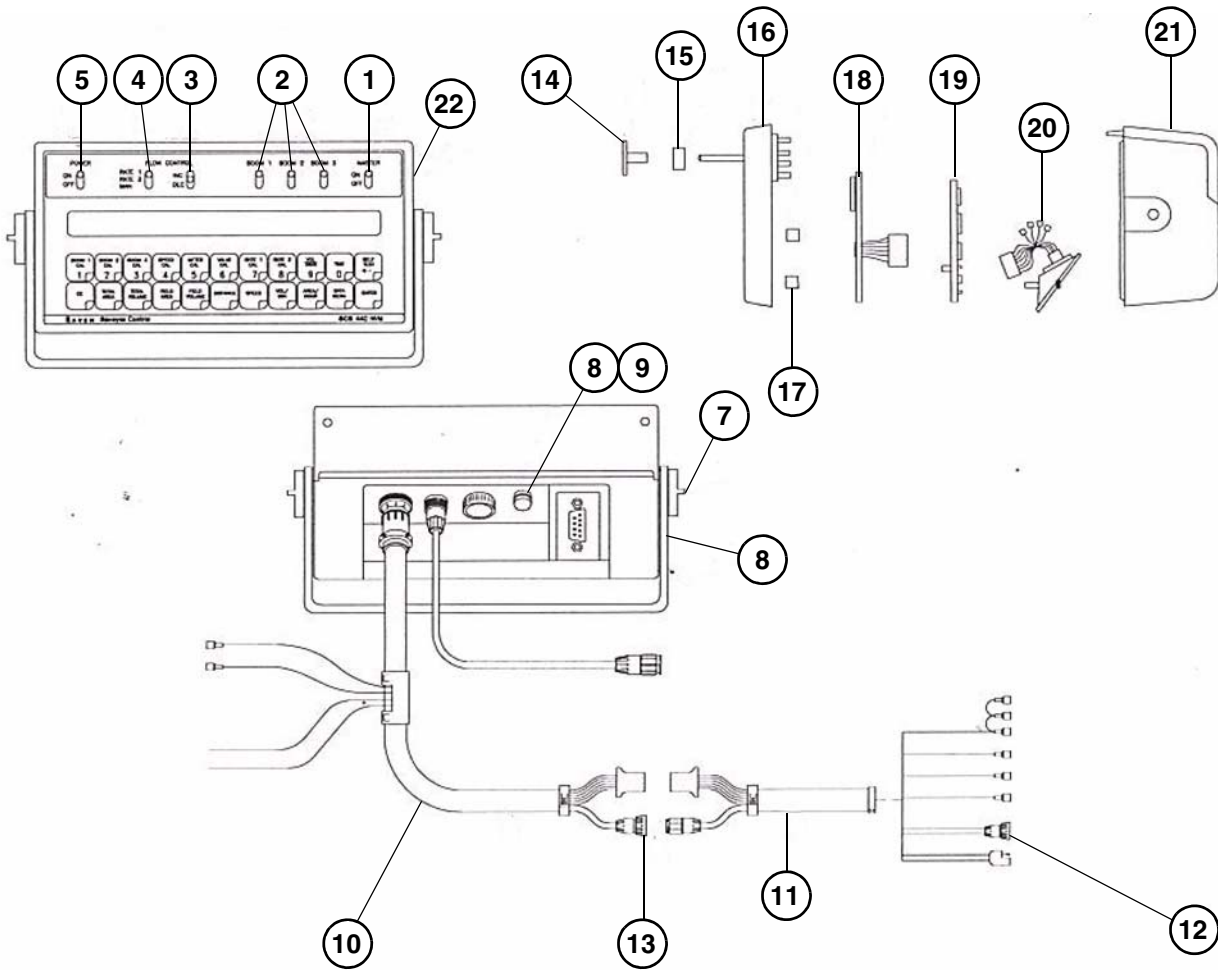

P00809



ILLUSTRATED PARTS LIST (CONT'D)

Raven SCS440 Console (Cont'd)

ITEM NO.	PART NO.	DESCRIPTION	QTY.
1	412-2011-046	MASTER SWITCH	1
2	412-2011-047	BOOM SWITCH	3
3	412-2011-049	ADJ. SWITCH	1
4	412-2011-050	RATE 1/ RATE 2/ MANUALSWITCH	1
5	412-2011-048	POWER SWITCH	1
6	106-0159-437	MOUNTING BRACKET	1
7	106-0159-438	MOUNTING KNOB	2
8	510-2001-018	FUSE HOLDER	1
9	510-1003-003	FUSE, 15 AMP.	1
10	115-0159-418	CONSOLE CONTROL CABLE	AR
	115-0159-509	CONSOLE CONTROL CABLE (TURF)	AR
11	115-0159-404	FLOW CONTROL CABLE (6 FT.)	AR
	115-0159-017	FLOW CONTROL CABLE (12 FT.)	AR
12	115-0159-016	FLOW METER CABLE EXT (6 FT.)	AR
	115-0159-017	FLOW METER CABLE EXT (12 FT.)	AR
13	115-0159-409	FLOW EXT. CABLE (12 FT.)	AR
	115-0159-414	FLOW EXT. CABLE (24 FT.)	AR
14	106-0159-433	SWITCH COVER	1
15	117-0159-421	1-SET FILLER SPACE	1
16	063-0171-998	FACE PLATE ASSEMBLY	1
17	107-0159-478	DISPLAY BOARD SPACER	1
18	063-0171-961	LCD DISPLAY BOARD	1
19	064-0159-744	PROCESS BOARD	1
20	063-0171-999	CONNECTOR PLATE ASSEMBLY	1
21	063-0159-530	BACK ASSEMBLY	1
22	063-0171-183	SCS 440 CONSOLE (SERIAL INTERFACE)	1

ILLUSTRATED PARTS LIST (CONT'D)

Electrical Schematic Control Console Harness (155-0171-085)

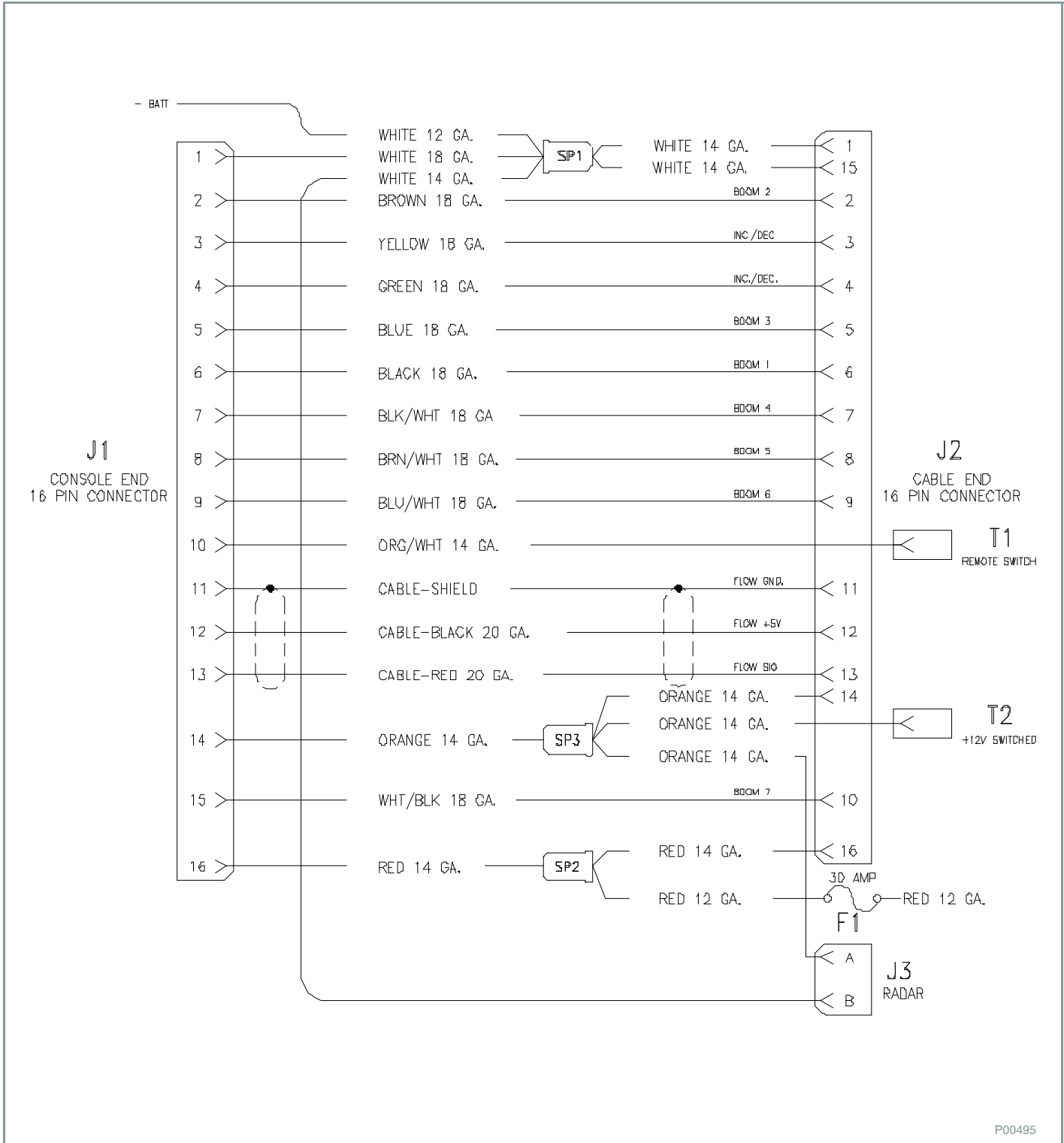

SYSTEM SCHEMATICS

Electrical Schematic Control Console Harness (155-0159-856)

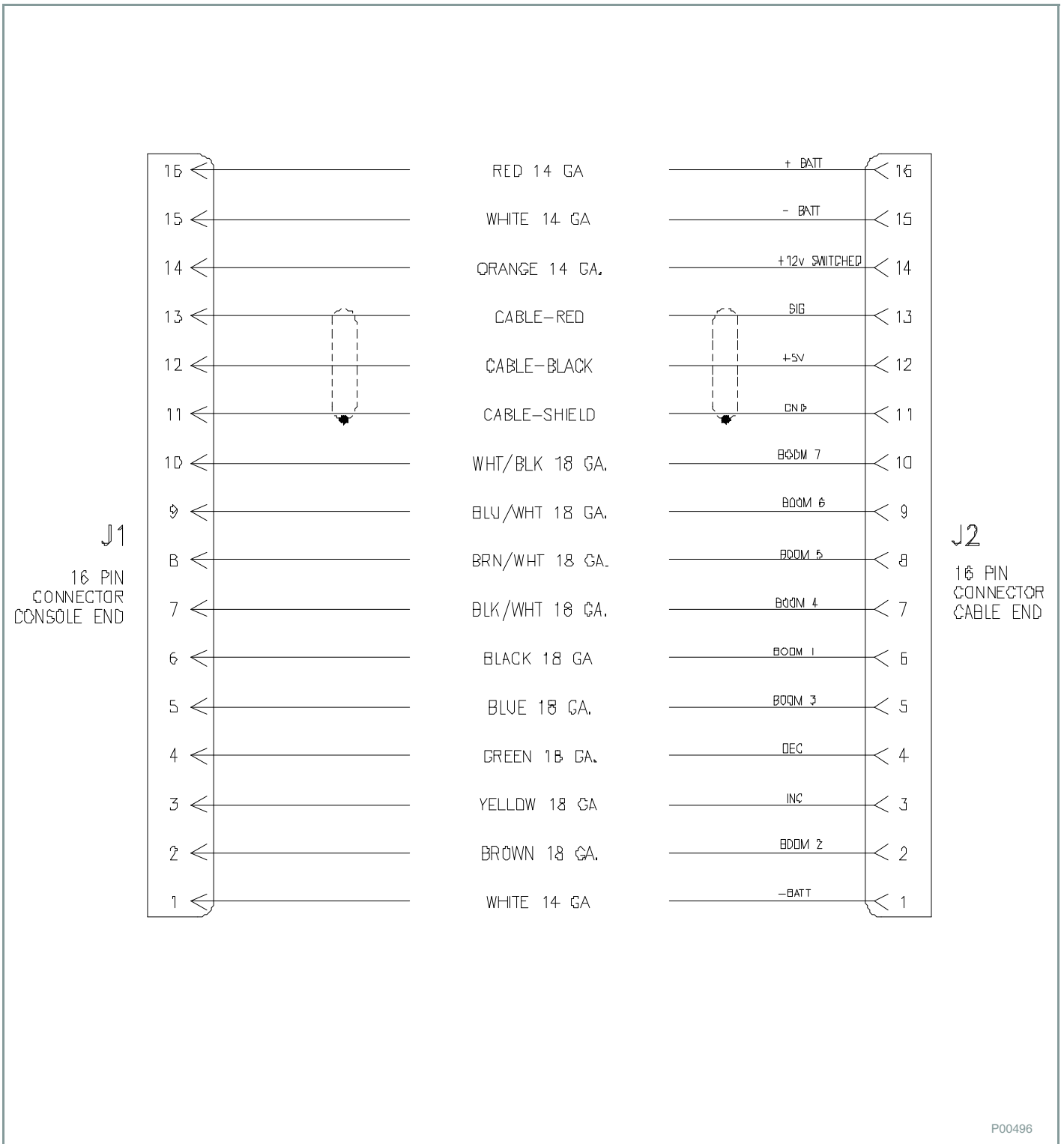

P00496

SYSTEM SCHEMATICS

Electrical Schematic Control Console Harness (155-0171-086)

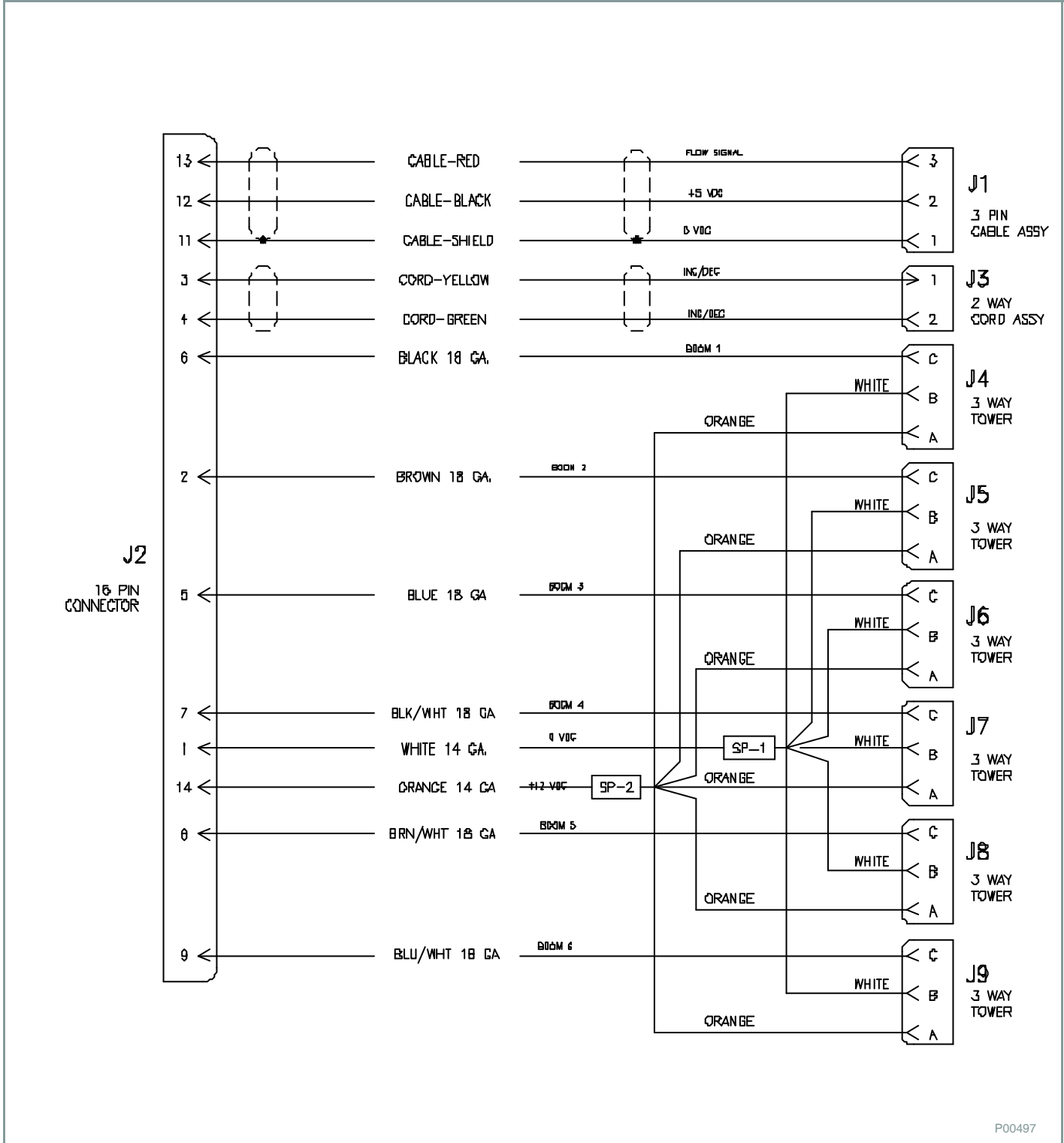

P00497



ILLUSTRATED PARTS LIST (CONT'D)

Product Controller Liquid System, 16 Pin Product Cable

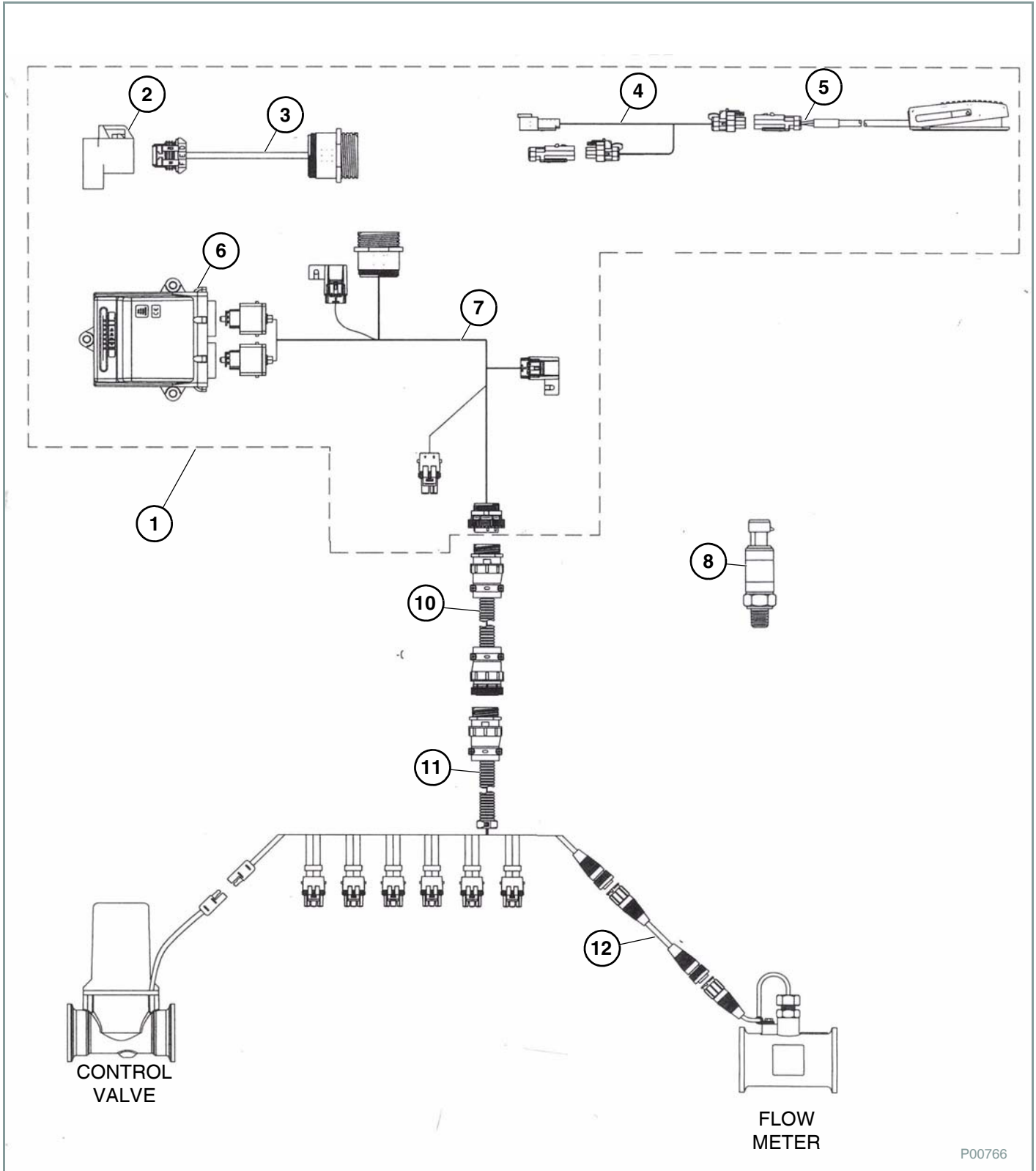

P00766



ILLUSTRATED PARTS LIST (CONT'D)

Product Controller Liquid System, 16 Pin Product Cable (Cont'd)

ITEM NO.	PART NO.	DESCRIPTION	QTY.
1*	117-6100-001	KIT, PRODUCT CONTROLLER, LIQUID 16 PIN	1
2	063-0172-964	TERMINATOR, ACTIVE, POWELL	1
3	115-0171-963	CABLE, RAVEN ISO TO ACTIVE TERMINATOR	1
4	115-0171-865	22 FT. FOOT SWITCH EXT	1
5	063-0173-080	FOOT SWITCH ISO NODE	1
6	063-0173-006	ISO PRODUCT CONTROLLER NODE	1
7	115-0171-949	PROD. CONTROLLER CABLE, 16 PIN	1
8	422-0000-090	PRESSURE SENSOR (OPTIONAL)	1
9	016-0171-362	PRODUCT CONTROLLER MANUAL (NOT SHOWN)	1
10	115-0159-856	12 FT. EXTENSION CABLE	1
	115-0159-857	24 FT. EXTENSION CABLE	
11	115-0171-086	12 FT. FLOW CABLE	1
	115-0171-129	24 FT. FLOW CABLE	
12	115-0159-016	6 FT. FLOW EXTENSION CABLE	1
	115-0159-017	12 FT. FLOW EXTENSION CABLE	
	115-0159-019	24 FT. FLOW EXTENSION CABLE	
	115-0171-544	36.5 FT. FLOW EXTENSION CABLE	

*-Kit contains items 2 through 9.

ILLUSTRATED PARTS LIST (CONT'D)

Cable, 17 Ft., ISO, Hitch To Raven ECU Assembly (115-0172-034) (Cont'd)

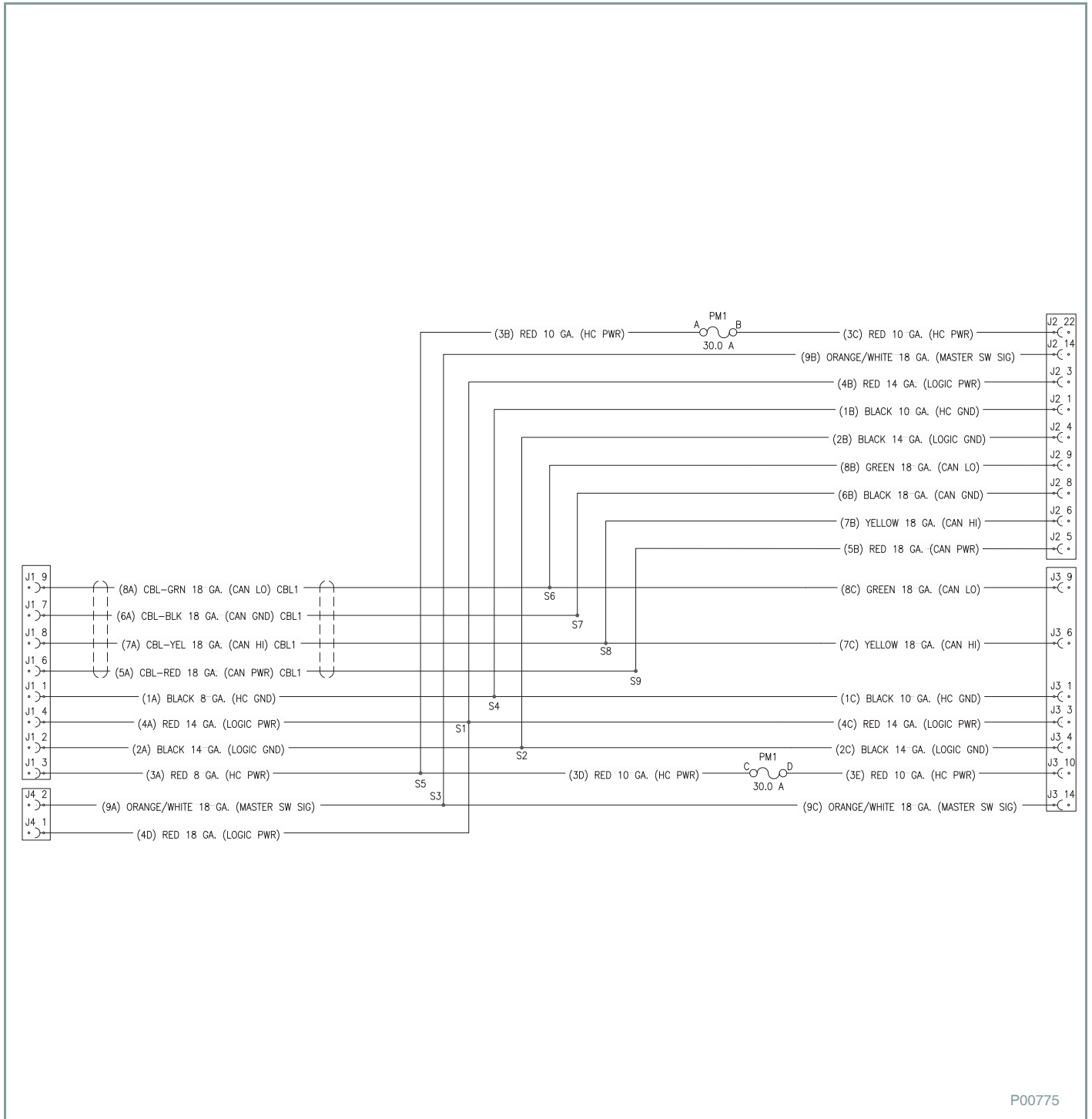

P00775

ILLUSTRATED PARTS LIST (CONT'D)

Raven, Cable, Adapter, ISO To Active Terminator Assembly (115-0171-963)

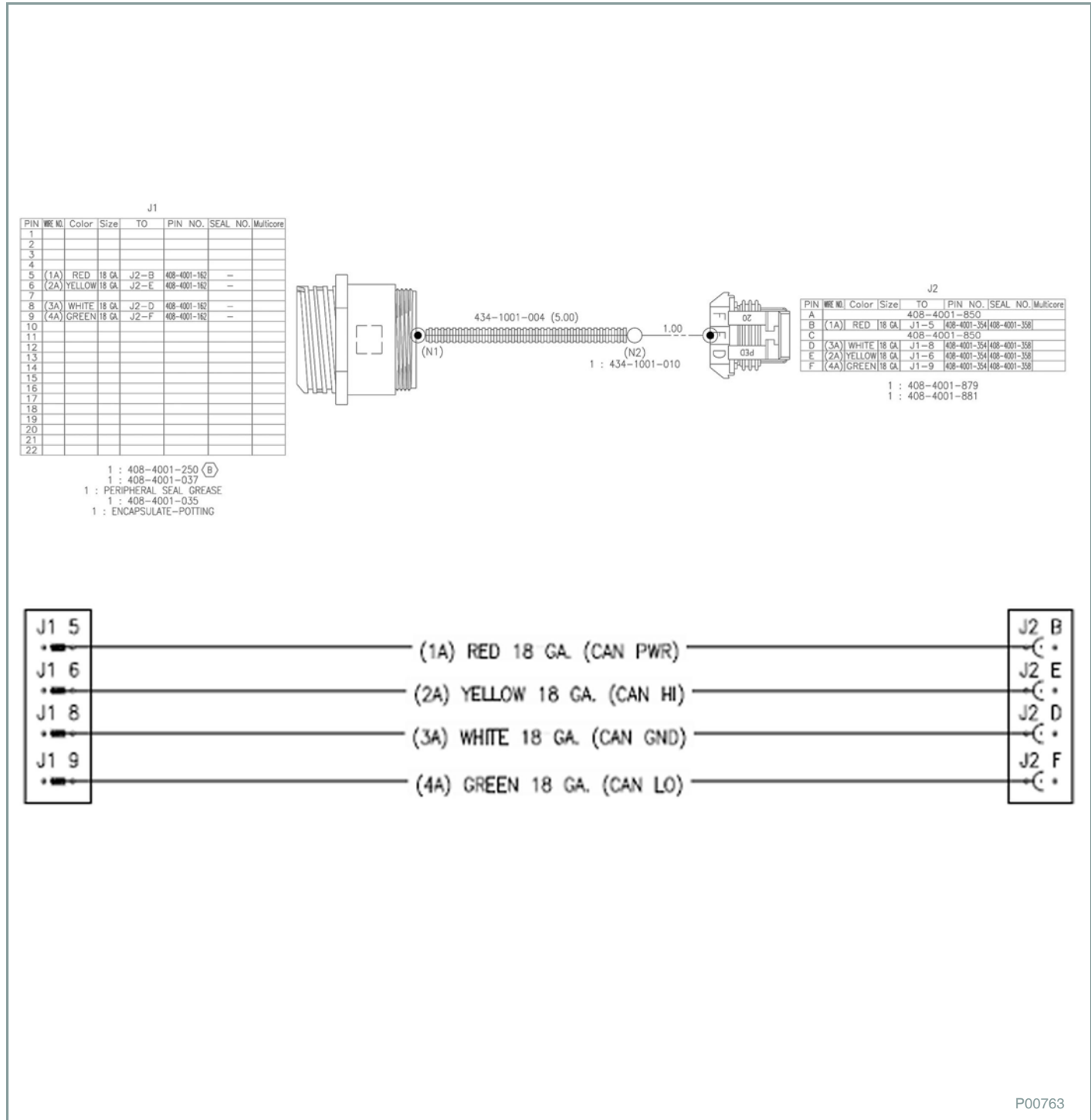

P00763

ITEM NO.	PART NO.	DESCRIPTION	QTY.
1	115-0171-963	RAVEN, CABLE ISO TO ACTIVE TERMINATOR ASSEMBLY	1



ILLUSTRATED PARTS LIST (CONT'D)

Hydraulic System

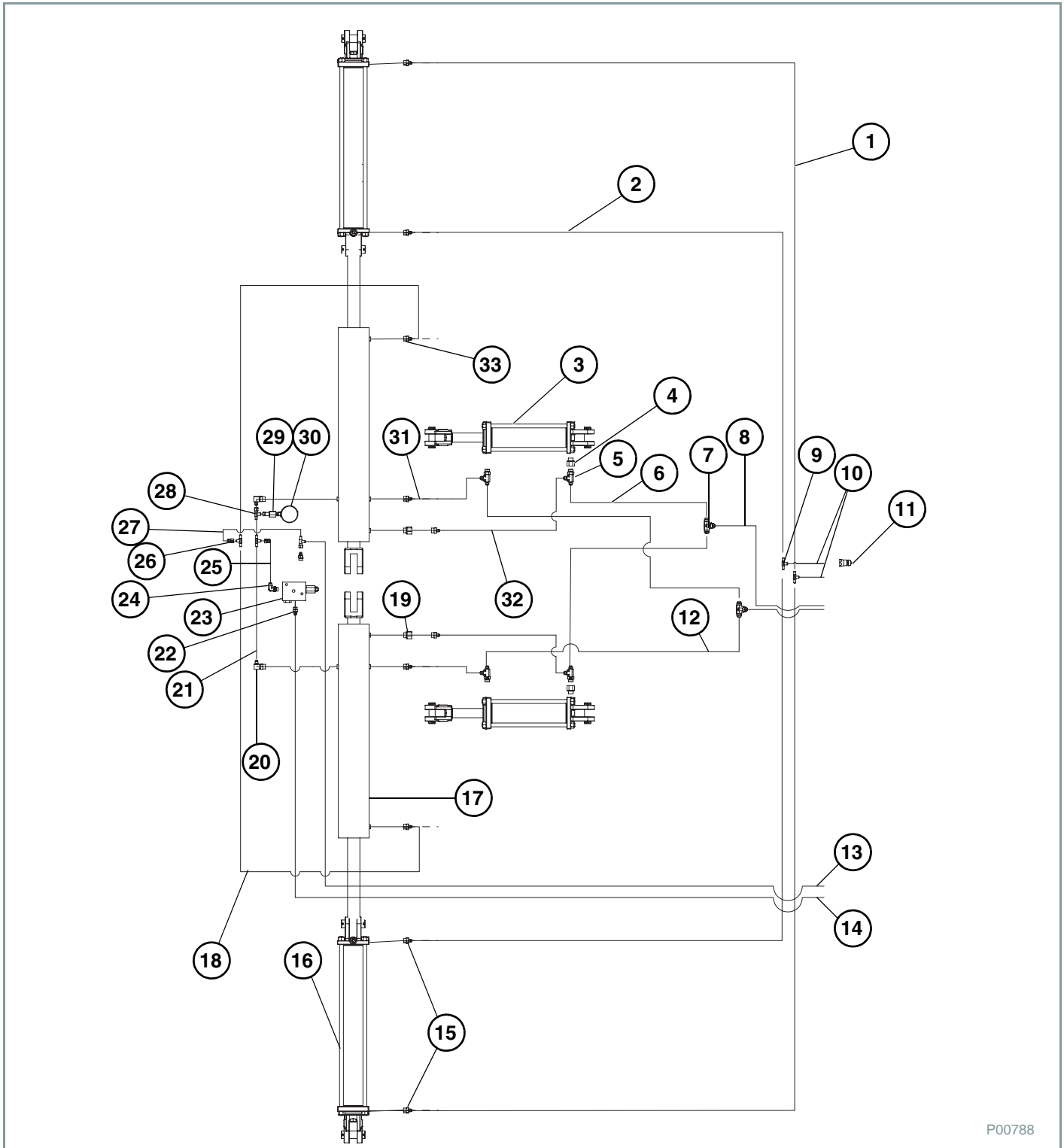

ILLUSTRATED PARTS LIST (CONT'D)
Hydraulic System (Cont'd)

ITEM NO.	PART NO.	DESCRIPTION	12 ROW QTY.	16 ROW QTY.
1	600045-7-ZN	FDM4R17-4FJXZ-4FJX90MZ-220	NA	2
2	600045-6-ZN	FDM4R17-4FJXZ-4FJX90MZ-200	NA	2
3	620073	CYLINDER 40TD10-150 DA 4 X 10" STROKE	2	2
NS	661729	KIT SEAL 4.0 BORE X 1.5 ROD	1	1
4	610095	FITTING ADAPTER 8ORB M/F .093 ORIFICE	2	2
5	610066	FITTING ADAPTER JIC SWIVEL RUN TEE TO-6804-06-08-06	4	4
6	600045-10-ZN	FDM6R17-6FJX90MZ-8FJXZ-68	2	2
7	610004	FITTING ADAPTER TEE 8JIC	2	2
8	FDM 0025-ZN	FDM8R17-8MBOZ-8FJXZ-183	2	2
9	610003	FITTING ADAPTER JIC TEE TO-2603-04-04-04	NA	2
10	FDM 0055-ZN	FDM4R17-8MBOZ-4FJX90MZ-305	2	2
11	520048	TIP HYDRAULIC ISO	6	6
12	600045-11-ZN	FDM6R17-6FJX90MZ-8FJXZ-80	2	2
13	600045-4A-ZN	FDM6R17-8MBOZ-6FJXZ-90M-281	1	1
14	600045-3-ZN	FDM6R17-8MBOZ-6FJXZ-273	1	1
15	610045	FITTING ADAPTER 8ORB TO 4JIC R0.045 (USED ON 620004)	NA	4
16	620057	CYLINDER 30TD16-150 3" X 16" STROKE	NA	2
NS	649208	KIT SEAL 3.0 BORE X 1.5 ROD	1	1
17	620027	CYLINDER DUAL FUCTION 45WD22.5 X 1.81 WK	2	2
NS	PMI0002	KIT SEAL 4.5 BORE X 2.0 ROD	1	1
18	FDM 0048-ZN	FDM4R17-4FJXZ-4FJX90MZ-85	2	2
19	610096	FITTING ADAPTER 8ORB M/F .047 ORIFICE	2	2
20	610029	FITTING ADAPTER 8ORB TO 4JIC 90°	2	2
21	600056-1-ZN	FDM4R17-4FJXZ-4FJXZ-63	2	2
22	610010	FITTING ADAPTER 6ORB TO 6JIC	1	1
23	630038	BLOCK DOWN PRESSURE (1PDCP25-PT-12S)	1	1
24	610078	FITTING ADAPTER 6ORB TO 6JIC 90°	1	1
25	600045-1A-ZN	FDM6R17-6FJXZ-6FJX90MZ-25	1	1
26	610002	FITTING ADAPTER 2406-04-06	2	2
27	600045-2A-ZN	FDM6R17-6FJXZ-6FJX90MZ-25.5	1	1
28	610026	FITTING ADAPTER JIC SWIVEL RUN TEE TO-6602-04-04-04	1	1
29	610025	FITTING ADAPTER 6506-4-4	1	1
30	790052	GAUGE PRESSURE 0-3000 PSI	1	1
31	ZN600056-2-ZN	FDM4R17-6FJXZ-4FJX90MZ-50	2	2
32	600056-3-ZN	FDM4R17-6FJXZ-4FJX90MZ-60	2	2
33	610009	FITTING ADAPTER 8ORB TO 4JIC	6	6

ILLUSTRATED PARTS LIST (CONT'D)

Pump Hydraulic System

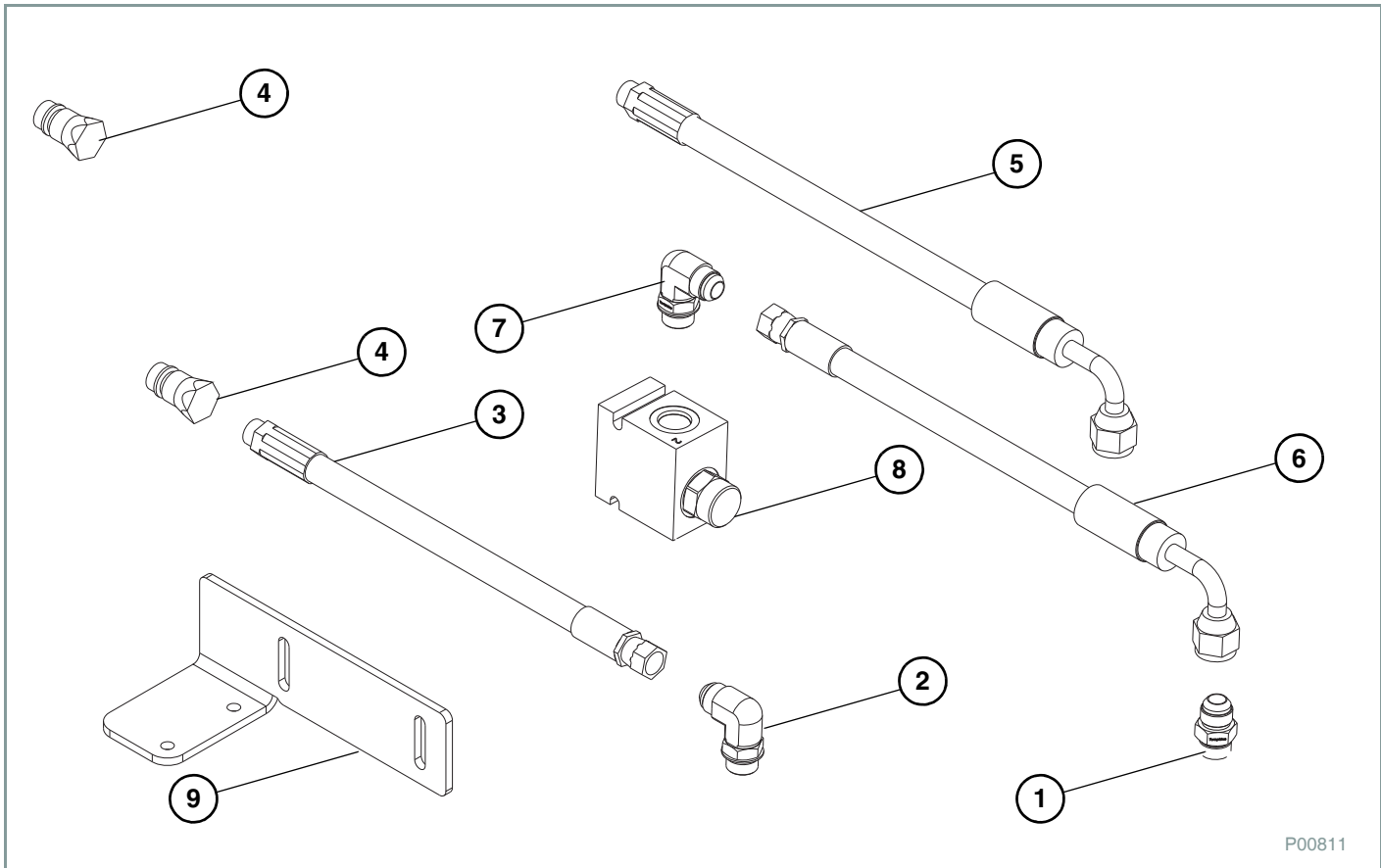

P00811

ITEM NO.	PART NO.	DESCRIPTION	QTY.
1	610060-ZN	ADAPTER 8JIC TO 10ORB	1
2	610086-ZN	ADAPTER 8JIC TO 10ORB 90°	1
3	PA600074-1-ZN	HOSE RETURN	1
4	520048	HOSE TIP	2
5	PA600074-2-ZN	HOSE PRESSURE	1
6*	610122	HOSE JUMPER	1
7*	610102	ADAPTER 10JIC TO 10ORB 90°	1
8*	610100	OVER SPEED VALVE 7.5GPM	1
9*	12954BLK	MOUNT OVER SPEED VALVE	1
NS*	596119M	BOLT HEX HD 5/16 X 3 GR5	2
NS*	596130M	BOLT HEX HD 3/8 X 2 GR5	2
NS*	596228M	NUT, HEX 5/16	2
NS*	596229M	NUT, HEX 3/8	2

* - Only used on option Over Speed Valve.

ILLUSTRATED PARTS LIST (CONT'D)

Lighting

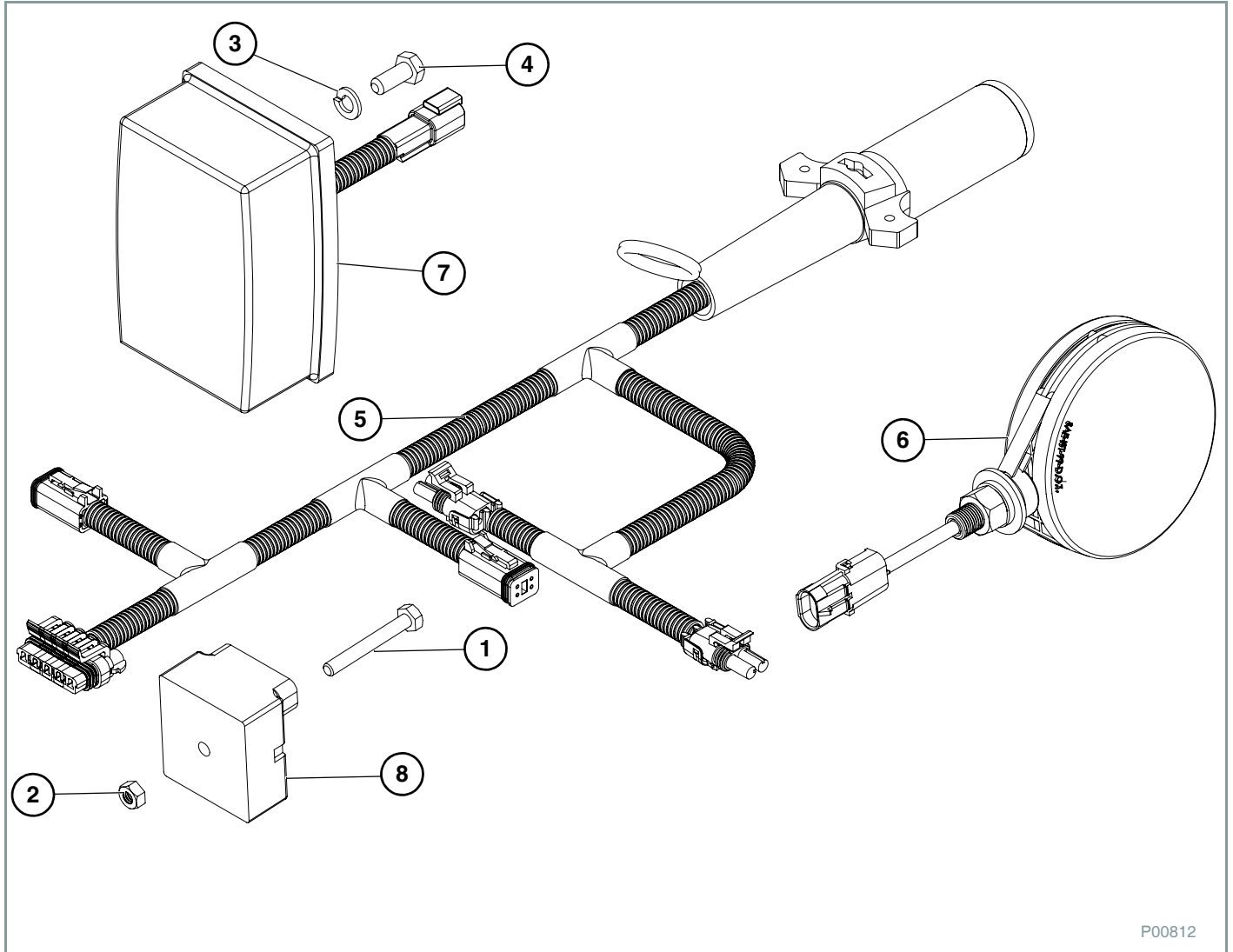

P00812

ITEM NO.	PART NO.	DESCRIPTION	QTY.
1	104	BOLT, 1/4 X 2" GRADE 5 ZP	1
2	235	NUT, CENTERLOCK, 1/4" ZP	1
3	249	WASHER, LOCK, 5/16" ZP	4
4	590229	BOLT, 8 X 20 MM 8.8 ZP	4
5	740023	APPLICATOR LIGHT WIRING HARNESS	1
6	740024	AMBER WARNING LIGHT	2
7	740025	RED TAIL LIGHT	2
8	740031	LIGHT MODULE	1





WARRANTY

WARRANTY131



WARRANTY

WARRANTY

FAST Equipment

FAST AG Solutions warrants to the buyer that the new machinery is free from defects in material and workmanship.

This warranty is only effective as to any new machinery which has not been altered, changed, repaired or treated since its delivery to the buyer, other than by FAST AG Solutions or its authorized dealers or employees, and does not apply to accessories, attachments, tools or parts, sold or operated with the new machinery, if they have not been manufactured by FAST DISTRIBUTING.

FAST AG Solutions shall only be liable for defects in the materials or workmanship attributable to faulty material or bad workmanship that can be proved by the buyer, and specifically excludes liability for repairs arising as a result of normal wear and tear of the new machinery or in any other manner whatsoever, and without limiting the generality of the foregoing, excludes application or installation of parts not completed in accordance with FAST AG Solutions operator's manual, specifications, or printed instructions.

Written notice shall be given by registered mail, to FAST AG Solutions within seven (7) days after the defect shall have become apparent or the repairs shall have become necessary, addressed as follows:

FAST AG Solutions
4130 Commerce Blvd
Windom, MN 56101

This warranty shall expire one (1) year after the date of delivery of the new machinery.

If these conditions are fulfilled, FAST shall at its own cost and at its own option either repair or replace any defective parts provided that the buyer shall be responsible for all expenses incurred as a result of repairs, labor, parts, transportation or any other work, unless FAST has authorized such expenses in advance.

The warranty shall not extend to any repairs, changes, alterations, or replacements made to the new equipment other than by FAST or its authorized dealers or employees.

This warranty extends only to the original owner of the new equipment.

Rubber parts (including tires, hoses, grommets) are not warranted.

This warranty is limited to the terms stated herein and is in lieu of any other warranties whether express or implied, and without limiting the generality of the foregoing, excluded all warranties, express or implied or conditions whether statutory or otherwise as to quality and fitness for any purpose of the new equipment. FAST disclaims all liability for incidental or consequential damages.

This Applicator is subject to design changes and FAST AG Solutions shall not be required to retrofit or exchange items on previously sold units except at its own option.

FAST AG Solutions

Warranty void if not registered.



Warranty Department

Printed in U.S.A.





ALPHABETICAL INDEX

EQUIPMENT SPECIFICATIONS	26
FEATURES AND ACCESSORIES	5
FIELD OPERATION	48
FIRE PREVENTION	11
GENERAL DESCRIPTION	24
GENERAL INFORMATION AND OPERATING INSTRUCTION SAFETY PRECAUTIONS ..	21
ILLUSTRATED PARTS LIST	69
INTRODUCTION	3
MAINTENANCE AND REPAIR SAFETY PRECAUTIONS	59
MAINTENANCE PROCEDURES	63
MAJOR COMPONENTS	25
MANUFACTURER'S INFORMATION	4
POST-OPERATION DISCONNECTION	53
PRE-OPERATION SETUP	32
PREVENTATIVE MAINTENANCE	59
PURPOSE OF EQUIPMENT	24
SAFETY IDENTIFICATION	14
SAFETY PRECAUTIONS	9
SERIAL NUMBER LOCATION	4
SIGN-OFF FORM	13
SPECIFICATIONS	64
STORAGE INSTRUCTIONS	55
TRANSPORTATION	54
TROUBLESHOOTING	66
WARRANTY	131





*4130 Commerce Blvd
Windom, MN 56101
Tel: (507) 427-3861 Fax: (507) 832-8407
www.fastsprayers.com*

Equipment shown is subject to change without notice.

© 2019 FAST AG Solutions, Printed in U.S.A.

#978