

FAST



8118 Liquid Fertilizer Applicator
Parts Manual
FAST Global Solutions
4130 Commerce Boulevard
Windom, MN 56101

General Information

All rights, especially copying and distribution rights are reserved. No part of this publication may be reproduced in any form or by any means, electronic or mechanical, including photocopying, without express written permission from Fast Distributing, Inc.

Parts information in this manual represents components installed when product was manufactured based upon the best available information. Modifications made subsequent to initial delivery are not included. Always verify the parts and color required with Fast Distributing, Inc at 1-800-772-9279.

If you have any questions, please contact your dealer or our Parts and Service Department.

Limited Warranty

Fast Global Solutions warrants to the buyer that the new machinery is free from defects in material and workmanship.

This warranty is only effective as to any new machinery which has not been altered, changed, repaired or treated since its delivery to the buyer, other than by FAST DISTRIBUTING or its authorized dealers or employees, and does not apply to accessories, attachments, tools or parts, sold or operated with the new machinery, if they have not been manufactured by FAST Global Solutions.

FAST Global Solutions shall only be liable for defects in the materials or workmanship attributable to faulty material or bad workmanship that can be proved by the buyer, and specifically excludes liability for repairs arising as a result of normal wear and tear of the new machinery or in any other manner whatsoever, and without limiting the generality of the foregoing, excludes application or installation of parts not completed in accordance with FAST Global Solutions operator's manual, specifications, or printed instructions.

Written notice shall be given by registered mail, to FAST Global Solutions within seven (7) days after the defect shall have become apparent or the repairs shall have become necessary, addressed as follows:

FAST Global Solutions
4130 Commerce Boulevard
Windom, MN 56101.

This warranty shall expire one (1) year after the date of delivery of the new machinery.

If these conditions are fulfilled, FAST shall at its own cost and at its own option either repair or replace any defective parts provided that the buyer shall be responsible for all expenses incurred as a result of repairs, labor, parts, transportation or any other work, unless FAST has authorized such expenses in advance.

The warranty shall not extend to any repairs, changes, alterations, or replacements made to the new equipment other than by FAST or its authorized dealers or employees.

This warranty extends only to the original owner of the new equipment.

Rubber parts (including tires, hoses, grommets) are not warranted.

This warranty is limited to the terms stated herein and is in lieu of any other warranties whether express or implied, and without limiting the generality of the foregoing, excluded all warranties, express or implied or conditions whether statutory or otherwise as to quality and fitness for any purpose of the new equipment. FAST disclaims all liability for incidental or consequential damages.

This Applicator is subject to design changes and FAST Global Solutions shall not be required to retrofit or exchange items on previously sold units except at its own option.

Fast Global Solutions

Warranty void if not registered.



FAST 8118 Series Applicator

Fast Applicator Serial Number 8118 - _____ - _____

Date Purchased ____/____/____

23 Coulters

Pump Manufacturer: Ace 205F-304 or Hypro HM1 (circle one)

Contents

General Information	2
8118 Cart	6
8118 Cart- Continued	8
axles	10
tire & rim	12
Units With Yellow tanks	12
Units With White tanks	12
8118 tank Parts	13
Center Section	14
main and f IIP WInGs Se Ct Ion	15
8118 tool Bar Gau Ge Wheel	16
8118 ausherman mountInG Clam P	17
ausherman VantaGe II f ertII izer Cou lter	18
8118 Cl Ymer Cou lter assemBl Y	20
Knife assemBl Y	22
8118 3 InCh QuIck f III	23
8118 3 InCh QuIck f III withStrainer	24
8118 tank to PumP Plum BlnG	25
h YPro PumP	26
O Pt lo n a l a Ce 205 PumP motor	27
O Pt lo n a l a Ce 304 PumP	28
a Gl t at Ion	29
PumP to Ball Valve	30
tool Bar Plum Bln G	32
r aVen sCs450 Console	33
Control Console harness - 155-0171-085	34
Control Console harness - 155-0159-856	35
Control Console harness - 155-0171-086	36
hYdrauIIc SYstem for PumP	37
hYdrauIIc SChemat IC	38
tool Box Carrier	40
Kit Contents	41
l IGhtInG	42

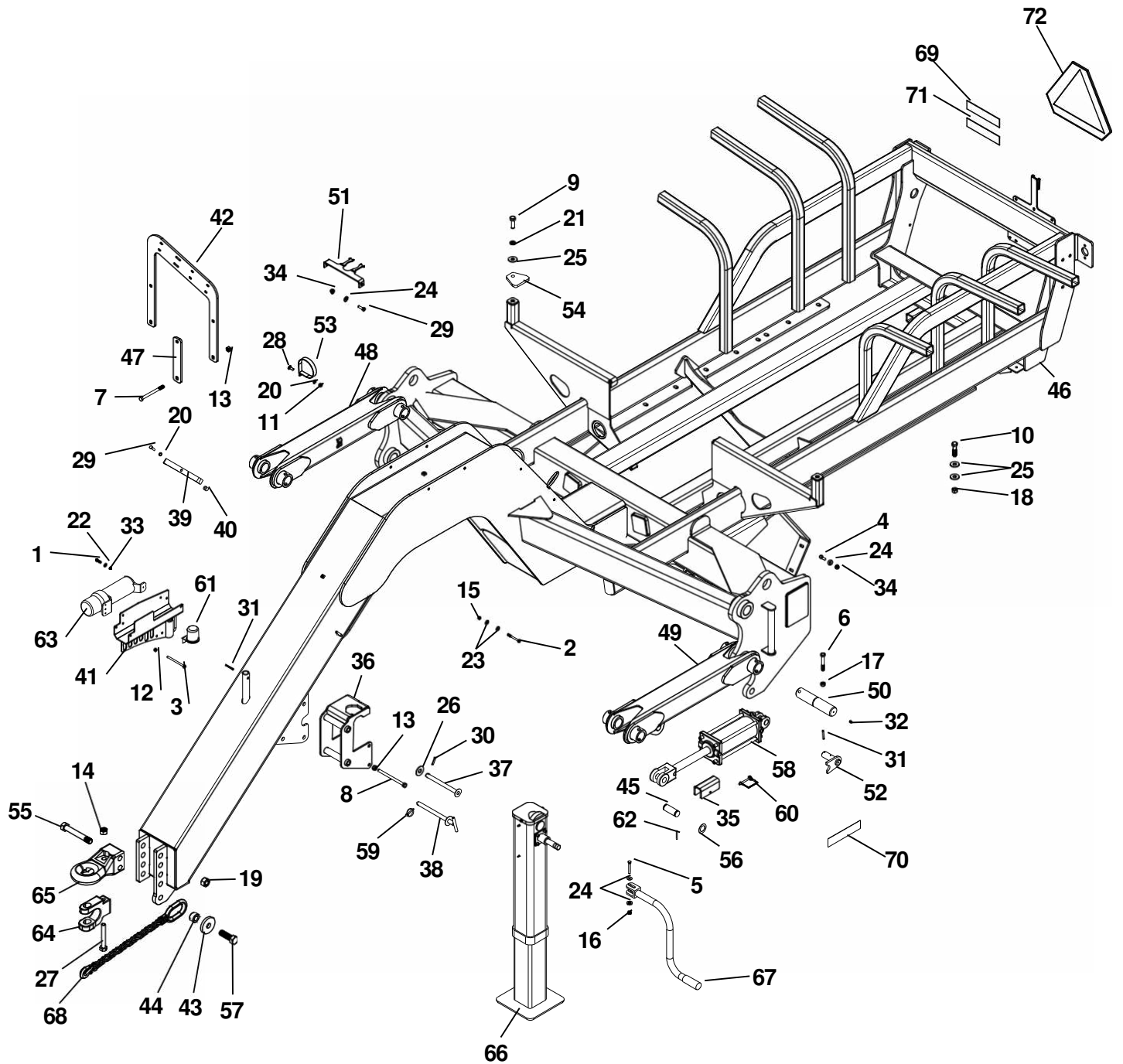

8118 Cart - Continued

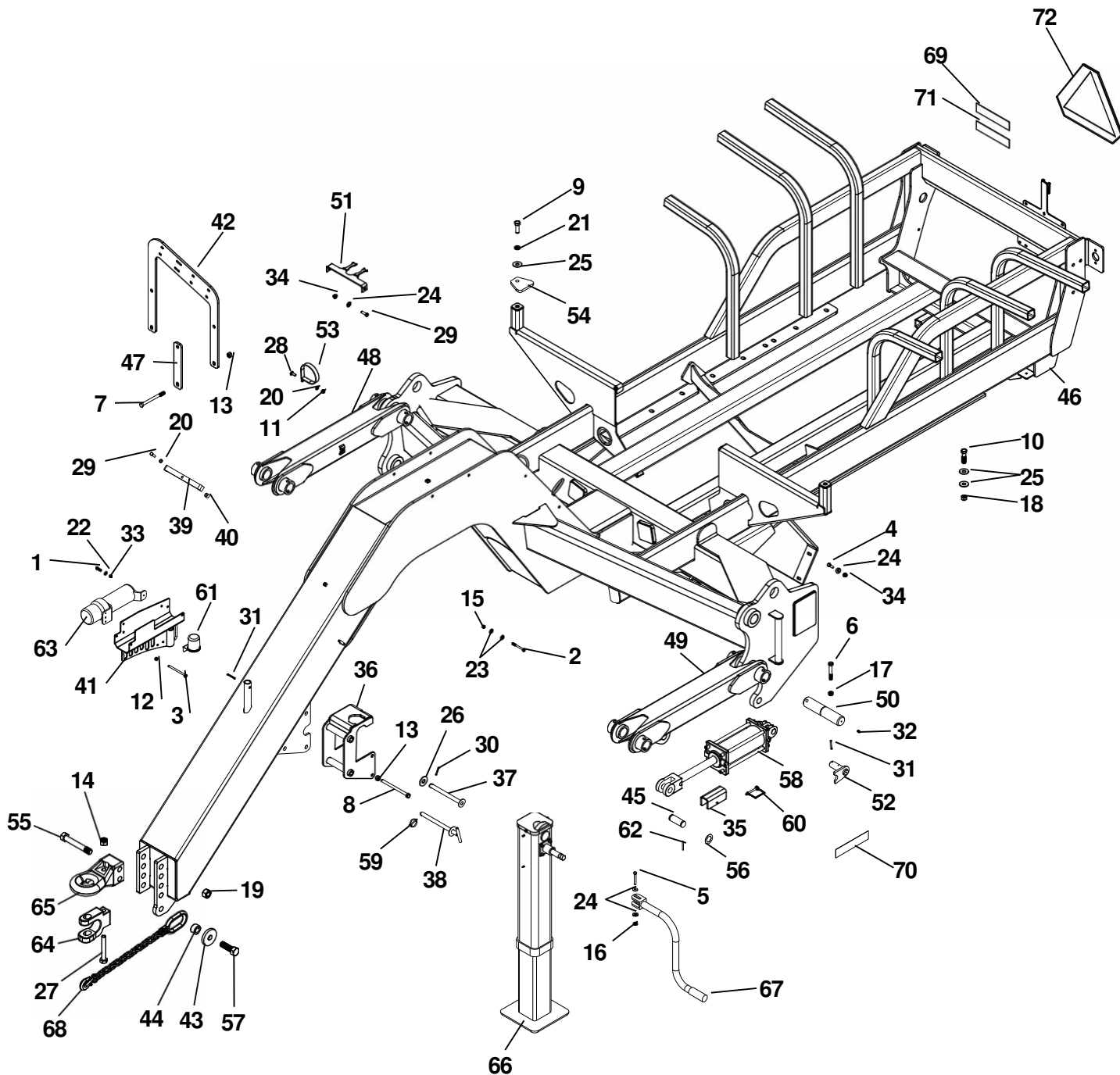

axles

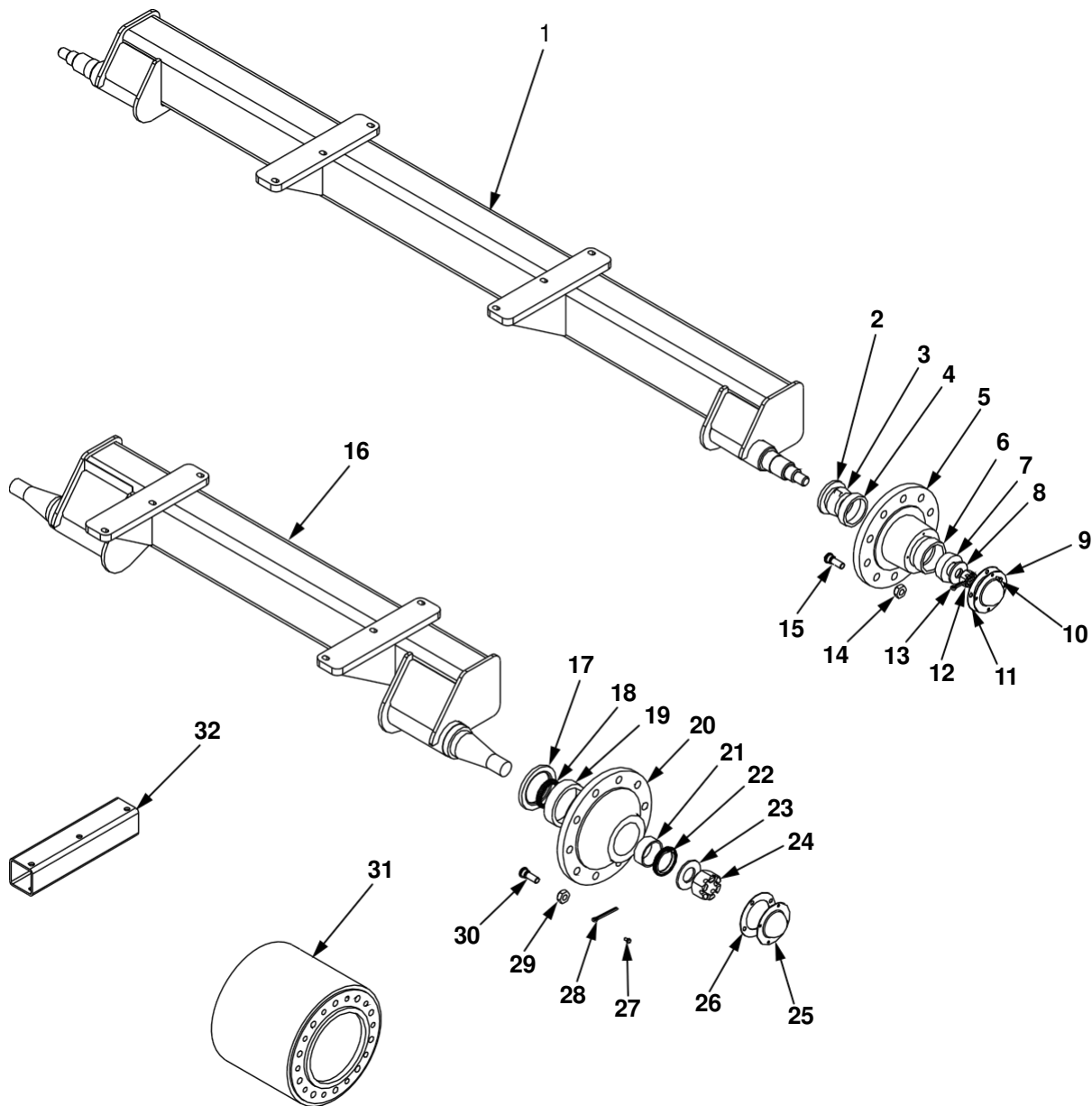

tire & rim

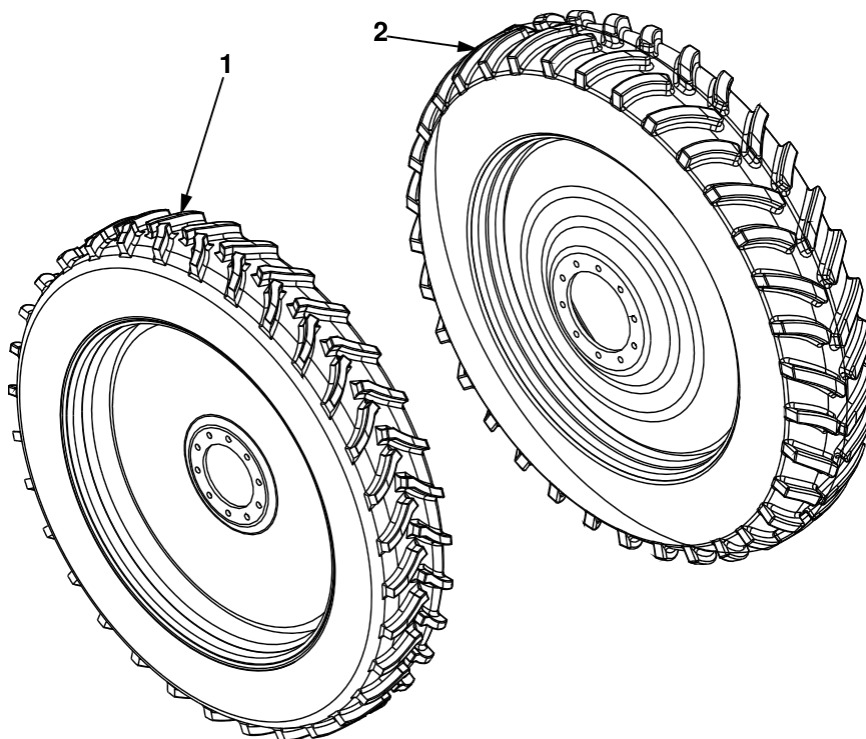

Units With Yellow tanks

Item	Vendor Part#	Fast Part#	TireDescription	8118
1	TT5123180057201R	700002	380/90R46 LR149 Tire/Wheel Yellow RH	1
1	TT5123180057201L	700003	380/90R46 LR149 Tire/Wheel Yellow LH	1
2	TT05193450057201L	700020	380/90R46 LR 149 Tire/Wheel Yellow Dual LH	2Opt.
2	TT05193450057201R	700021	380/90R46 LR 149 Tire/Wheel Yellow Dual RH	2Opt.

Units With White tanks

Item	Vendor Part#	Fast Part#	TireDescription	8118
1	TT5123180040701R	700001	380/90R46 LR149 Tire/Wheel Silver RH	1
1	TT5123180040701L	700000	380/90R46 LR149 Tire/Wheel Silver LH	1
2	TT05193450040701L	700034	380/90R46 LR 149 Tire/Wheel Silver Dual LH	2Opt.
2	TT05193450040701R	700035	380/90R46 LR 149 Tire/Wheel Silver Dual RH	2Opt.

8118Applicator



8118 tank Parts

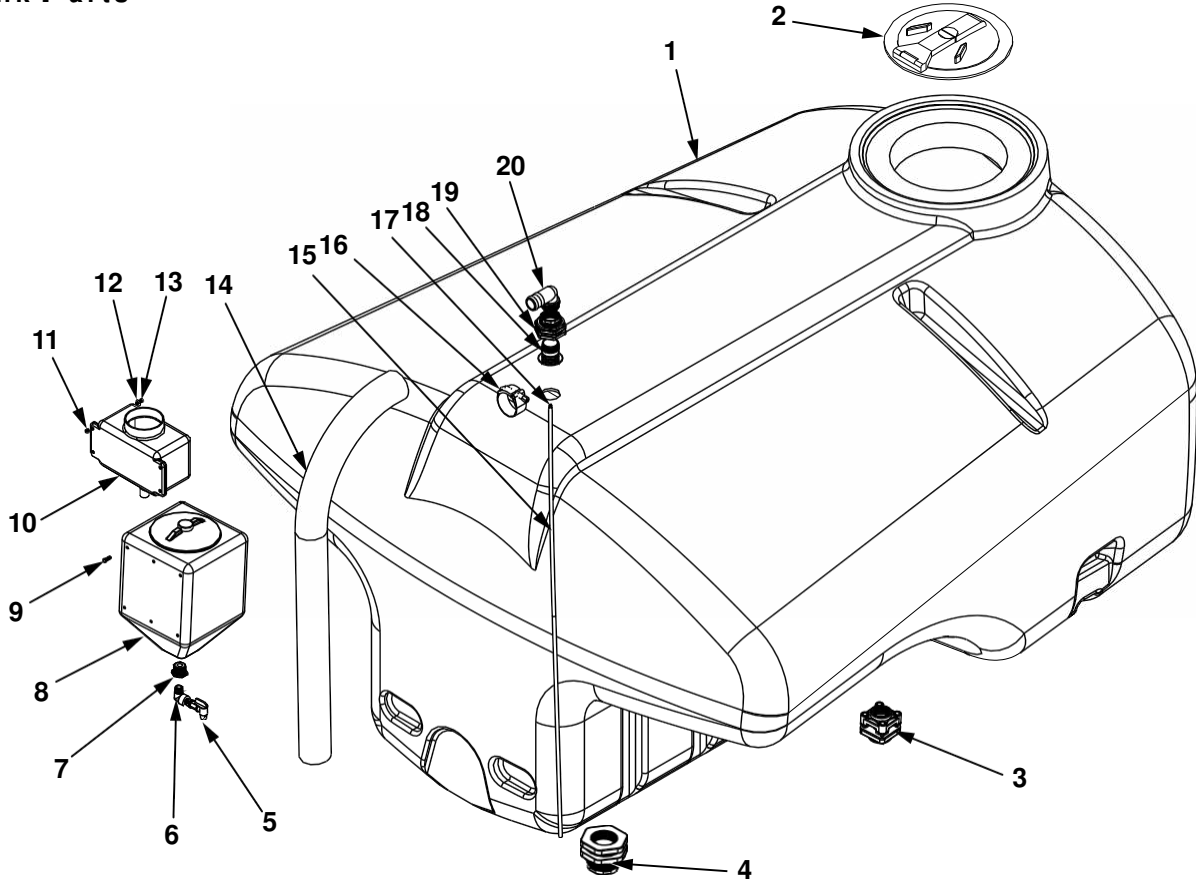

Item	Vendor Part#	Fast Part#	Description	Qty.
1	570089		Tank 1800 Gallon Yellow	1
NS	570088		Tank 1800 Gallon White	1
2	570070		Lid Assembly	1
3	530350		Fitting Tank (BJMBF222BD)	1
4	530164		3 Inch Polypro Tank Flange Assy	1
5	510022		3/4 Flo-Rite Faucet Clear	1
6	530151		3/4" Poly Street Elbow-90 Deg	1
7	530143		Bushing Reducer 1-1/4 To 3/4 NPT	1) Used On 10 Ga Opt.
8	570097		Tank 10 Gallon Rinse Yellow	1) Used On 10 Ga Opt.
NS	570092		Tank 10 Gallon Rinse White	1) Used On 10 Ga Opt.
9	114		Bolt Hex Head 5/16 X 3/4 Grade 5 Zp	6) Used On 10 Ga Opt.
10	570038		Tank 2.5 Gallon Rinse Yellow	1
NS	570044		Tank 2.5 Gallon Rinse White	Opt. W/ White Tank
11	228		Nut Hex Nylock Zp	4
12	257		Washer Flat 5/16" Zp	4
13	116		Bolt Hex Head 5/16 X 1-1/2 Grade 5 Zp	4
14	510025		Hose Overflow 2"	7Ft
15	510023		Burp Tube Pump	18Ft
16	540007		Clamp T Bolt	1
17	530004		1/4" X 1/4" Male Elbow	1
18	530331		2" Vent Cap Without Screen	1
19	530163		2" Poly Tank Fitting	1
20	530051		2" MPT X 2" Hose Shank-90	1

8118Applicator



Main and fIIP WIngS SeCtIon

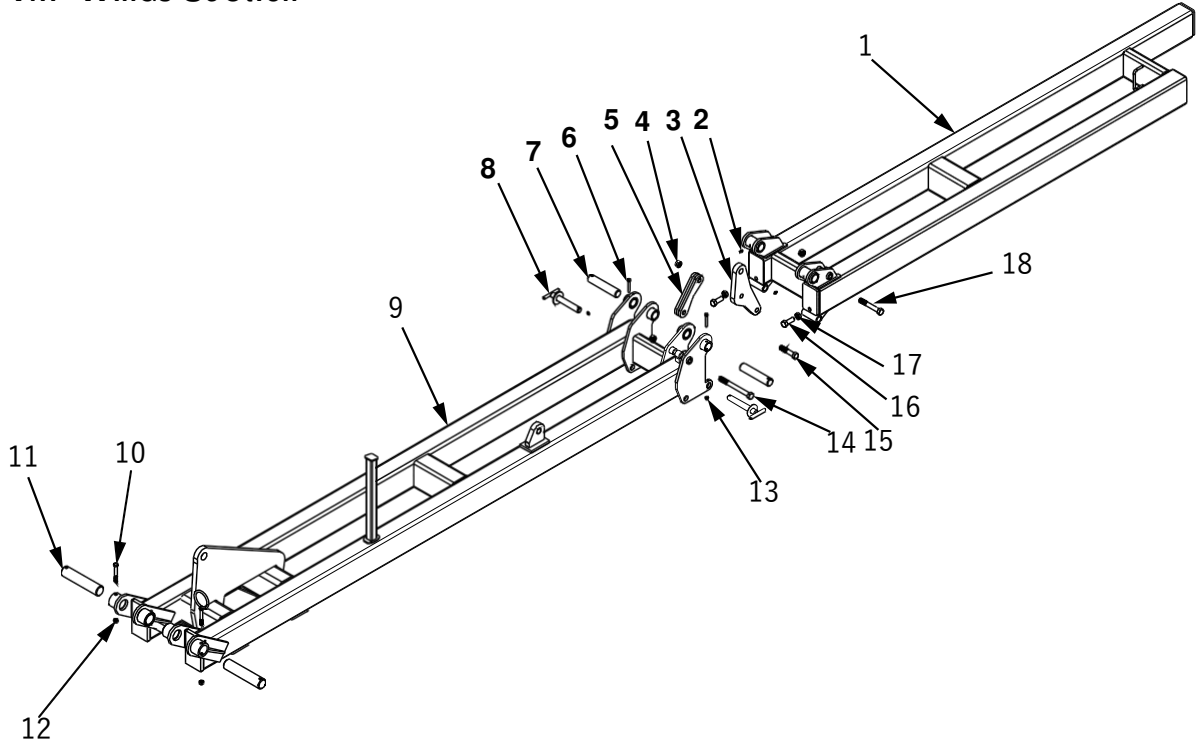

Item	Vendor Part#	Fast Part#	Description	Qty.
1		5503L	Flip Wing 60" Double Bar LH	1
NS		5503R	Flip Wing 60" Double Bar RH	1
2		759	Zerk 1/4-28 Zp	4
3		5539	Scissor Link 1"Boomerang	2
4		241	Nut Hex Head 3/4" Centerlock Zp	6
5		5543	Link ForkFolding	2
6		131	Bolt Hex Head 3/8 X 2-1/2 Grade 5Zp	4
7		5617	Pin Hinge 1-1/2	4
8		5743	Tee Handle LockPin	4
9		13910L	Wing Main 60" Double BarLH	1
NS		13910R	Wing Main 60" Double BarRH	1
10		157	Bolt Hex Head 1/2 X 3-1/2 Grade 5Zp	4
11		2120	Pin Pivot MainWing	4
12		238	Nut Hex Head 1/2" Centerlock Zp	4
13		237	Nut Hex Head 3/8" Centerlock Zp	4
14		396	Bolt Hex Head 3/4 X 7-1/2 Grade 8Zp	2
15		386	Bolt Hex Head 3/4 X 3-1/2 Grade 8Zp	2
16		184	Bolt Hex Head 3/4 X 2 Grade 5Zp	2
17		225	Nut Jam 3/4 Zp	4
18		389	Bolt Hex Head 3/4 X 5 Grade 8Zp	2

8118 tool Bar Gauge Wheel

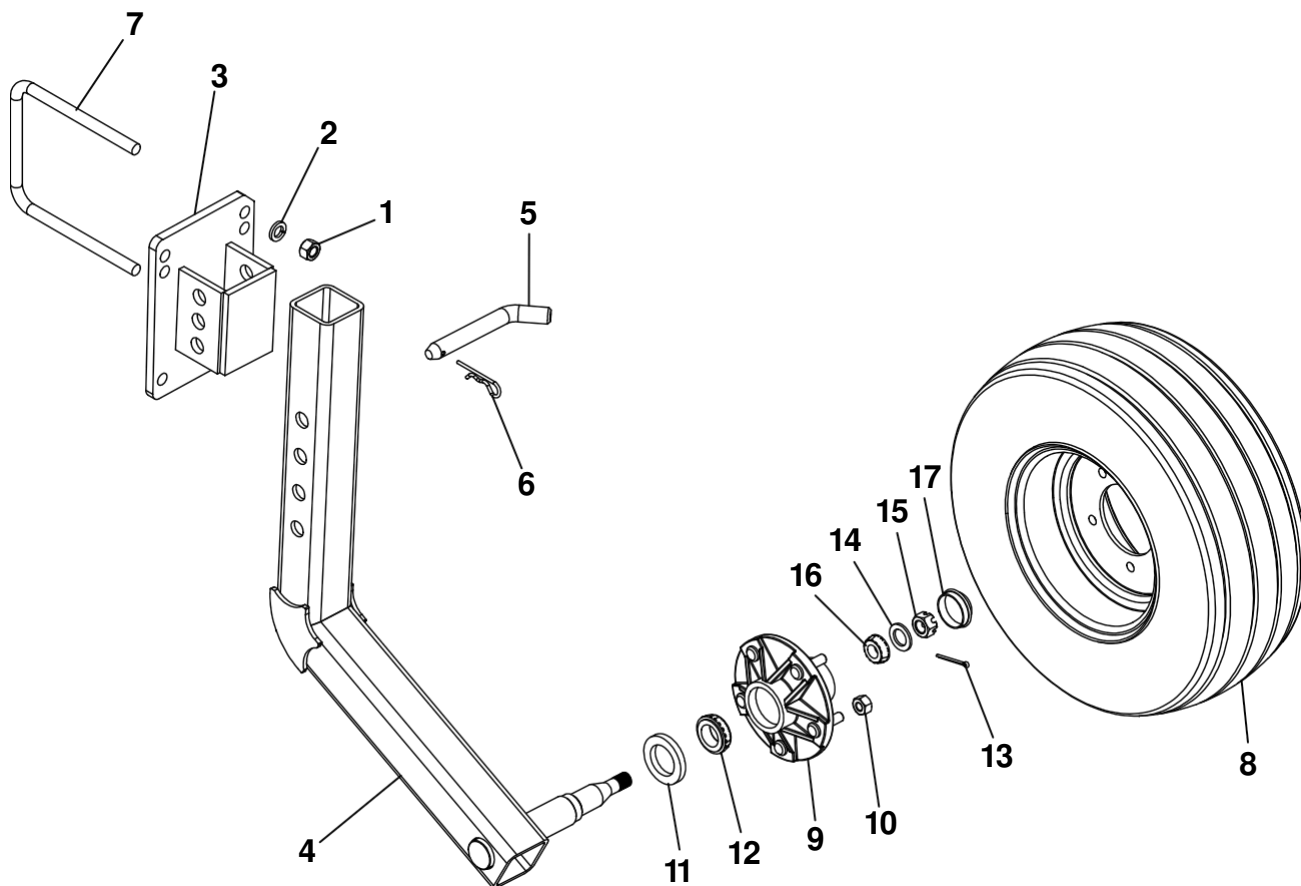

Item	Vendor Part#	Fast Part#	Description	Qty.
1		216	Nut HH 5/8" Zp	4
2		253	Washer Lock 5/8" Zp	4
3		19055L	LH Mounting Bracket	1
		19055R	RH Mounting Bracket	1
4		19060L	LH Gauge Wheel Weld	1
		19060R	RH Gauge Wheel Weld	1
5		19061	Pin Lock	1
6	HH-68870	590017	Pin Hair Pin Cotter	1
7	CA-FBU679	530170	U-Bolt 6 X 4 X 5/8" Zp	2
8	TT-1585001068	700023	Tire/Wheel 20.5	1
9	NIN250541	730026	Hub 5 Bolt WCups	1
10	NI912919	730030	Nut HH 1/2 X 20 Nfine Thread Zp	5
11	NIN906296	730031	Seal Hub	1
12	NIN910259	730032	Bearing Inner	1
13	NIN905936	730033	Pin, Cotter	1
14	NIN913608	730034	Washer Spindle	1
15	NIN912953	730035	Nut Castle	1
16	NIN910260	730036	Bearing Outer	1
17	NIN909931	730044	Cap, Hub	1
NS	NIN280741	730065	Spindle Only	AR
NS	NI910258		Cup Outer	NS
NS	NI910257		Cup Inner	NS

Case IH VantaGe II fertilizer Coulters

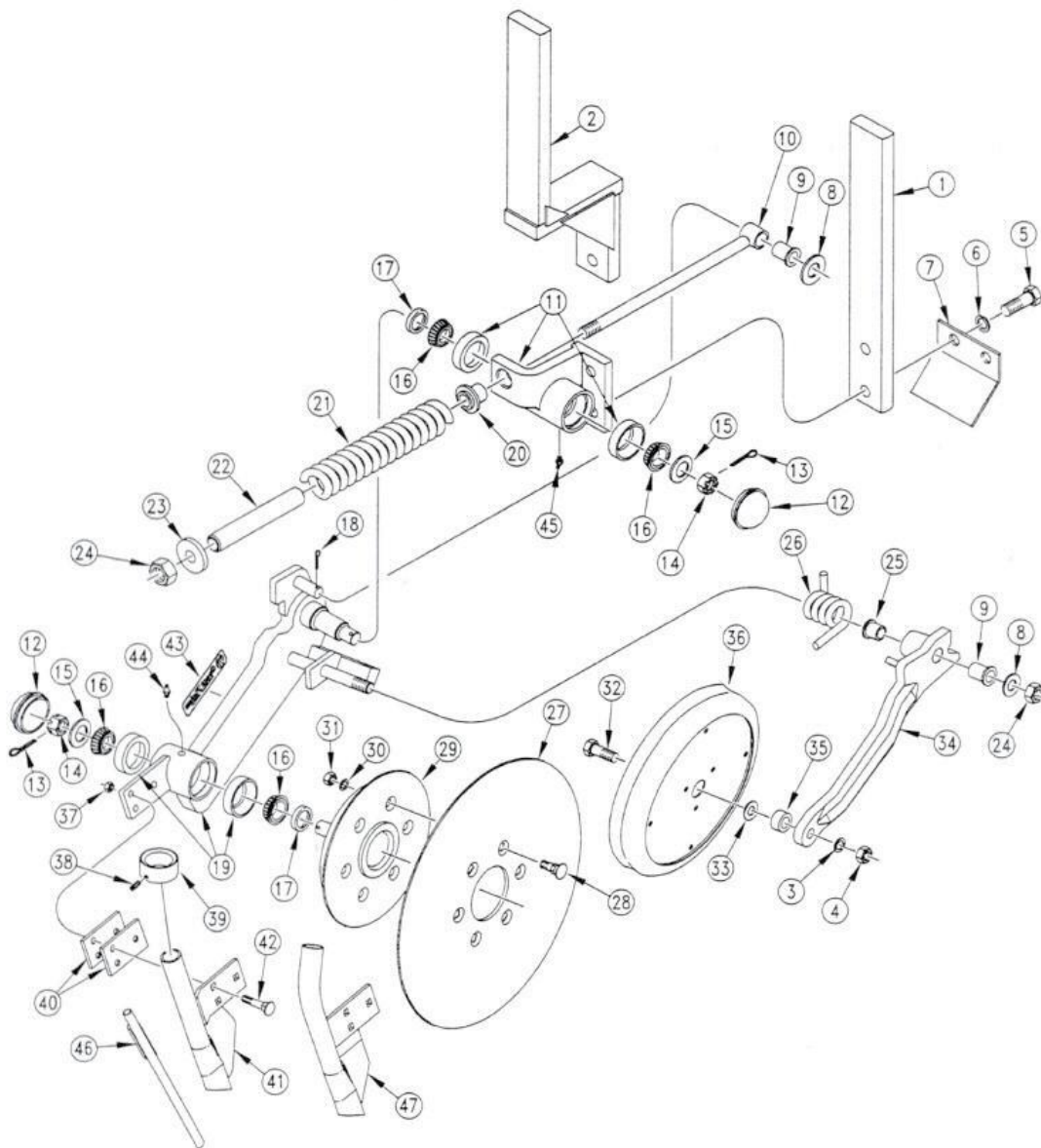

Item	Vendor Part#	Fast Part#	Description	Qty.
1	807-124C	750026	21" Flat Bar Angled Coulters Shank	
2	820-181C		Vanll 5" Offset Flat Shank RH (Shown)	
NS	820-182C		Vanll 5" Offset Flat Shank LH	
3	804-022C		Washer Lock Spring 5/8	
4	803-021C		Nut Hex 5/8-11 Plt	
5	802-064C		Hex Head Cap Screw 3/4-10 X 2 Grade5	
6	804-023C		Washer Lock Spring 3/4	
7	204-154D		FrontShield	

8118 CIMer Coulter Assembly

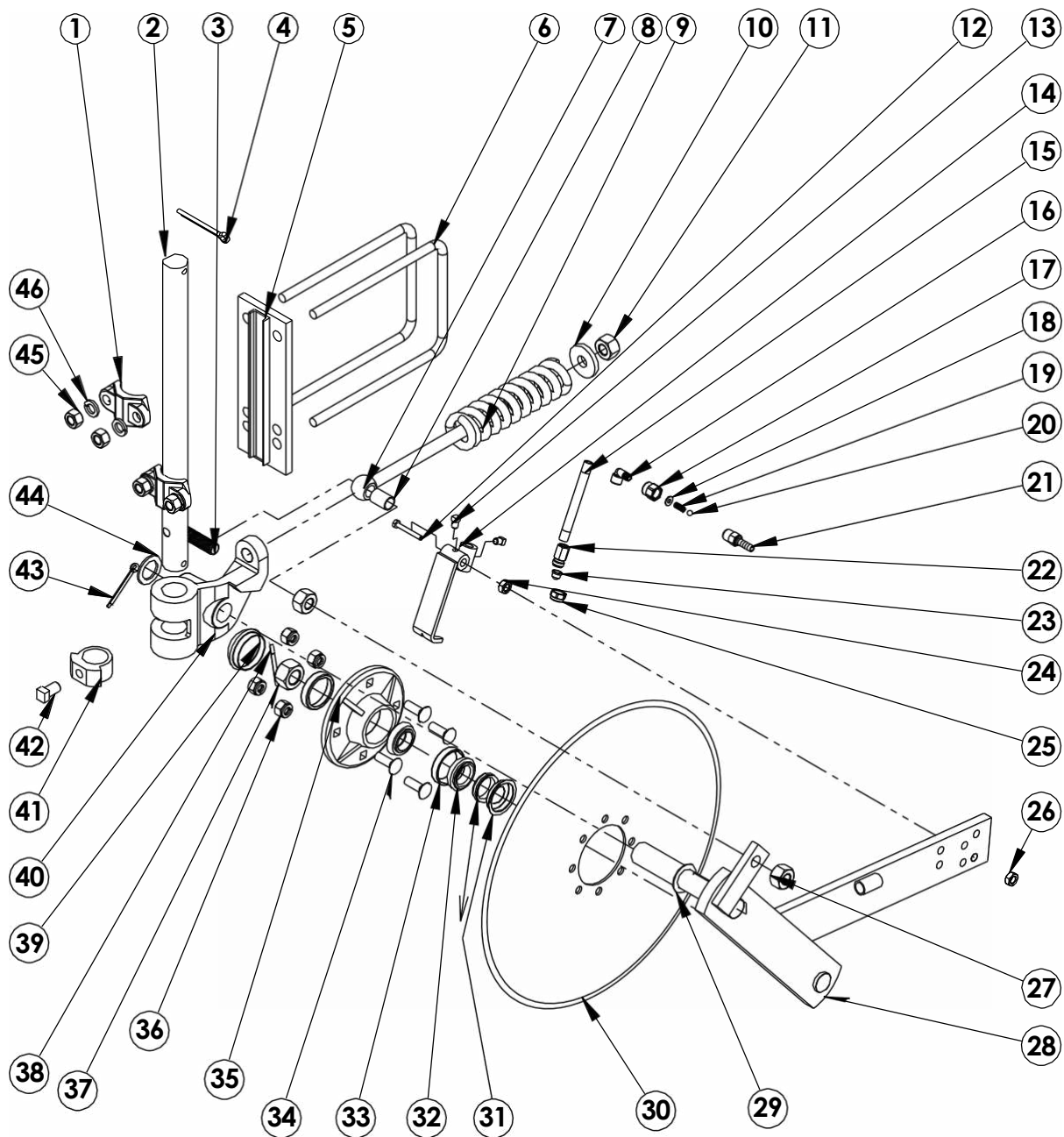

8118Applicator



Item	Vendor Part#	Fast Part#	Description	Qty.
1	N369	590005	Casting Clamp	2
2	N343	750012	1-1/2" Straight Coulter Shank	1
NS	N345	750055	1-1/2" Offset Coulter Shank	AR
NS		750054	1-1/2" Offset Coulter Shank Special	AR
NS		750053	1-1/2" Offset Coulter Shank Special	AR
3		186	Bolt HH 3/4 X 3 Grade 5Zp	1
4	FPC510		Cotter Pin 5/16" X3	2
5	N367-1		Clamp Plate	1
6	FBU679		U-Bolt 6 X 8-1/2 X 5/8 E-Coat (6 X 4Tube)	2
7	N347-7		Bushing Nylon For Spring Rod	1
8	N347-5		Spring Rod	1
9	S233		Spring Coulter	1
10	N347-3		Spring Bushing Casting	1
11		233	Nut HH 3/4 Nylock Zp	1
12	FBH0816-SS	750010	Bolt HH 1/2 X 4 Grade 5SS	1
13	FBS0602	750018	Set Screw 3/8 X 1/2"	2
14	COI100-7	750016	Rock Guard	1
15		530199	Nipple, Pipe 1/4 X 5SS	1
16		530246	Elbow, Street 1/4" NPTSS	1
		530188	Hose Shank Check Valve Assembly Items 17-21	1
17	TJ-4676-22-1/4		Adapter 11/16" X 1/4" NPT	1
18	TJ-CP4916-250		Orifice Plate 302 SS	1
19	TJ-CP3655-5-SS		Spring 5# 302SS	1
20	TJ-CP7671-5/16/SS		Ball 302SS	1
21	TJ-39189-8400-406-SS		Hose Shank 11/16 X 1/4" NPT 303 SS	1
22	TJ-CP1321-SS	520014	Teejet Bodt SS	1
23	TP-00xx-SS		Tip SS Teejet (Specify Tip Size)	1
24	FNJ08-SS	750009	Hut HH Jam 1/2" SS	1
25	TJ-CP1325SS	750015	Nozzle Cap SS	1
26	FNJL08-SS	750011	Nut HH Nylock 1/2" SS	1
27	FNL12-NF		Nut HH 3/4" NF Zp	1
28	N347-47		Swing Arm W Hub	1
29	N347-6		Bushing Coulter Flanged	1
30	N342	750014	Coulter Ripple 20"	1
31	W40-2		Seal Coulter 2 Piece	1
32	W32		Bearing	2
33	W38		Cup	2
34	FBC0806		Bolt Carriage 1/2" X 1-1/2" Zp	4
35	W23Y		Hub Assembly Complete (Items 31-33,35,37-39)	1
	W23		Hub Only	1
36	FNH08		Nut HH 1/2: Zp	4
37	W60		Nut Spindle 5/8"	1
38	FPC497		Pin Cotter 1/8" X 1-1/4"	1
39	W50		Cap Hub	1
40	N347-1		Coulter Hinge Casting	1
41	N347-2	750008	Locking Collar 30 Degree	1
NS	N342-2/45		Locking Collar 45 Degree	Opt.
42	FBS1004		Setscrew 5/8" X 1"	1
43	FPC505		Pin Cotter 1/8" X 1-1/4"	1
44	FWM18		Bushing 1/8" Thick	1
45		216	Nut HH 5/8" Zp	4
46		253	Washer Lock 5/8"	4

Knife Assembly

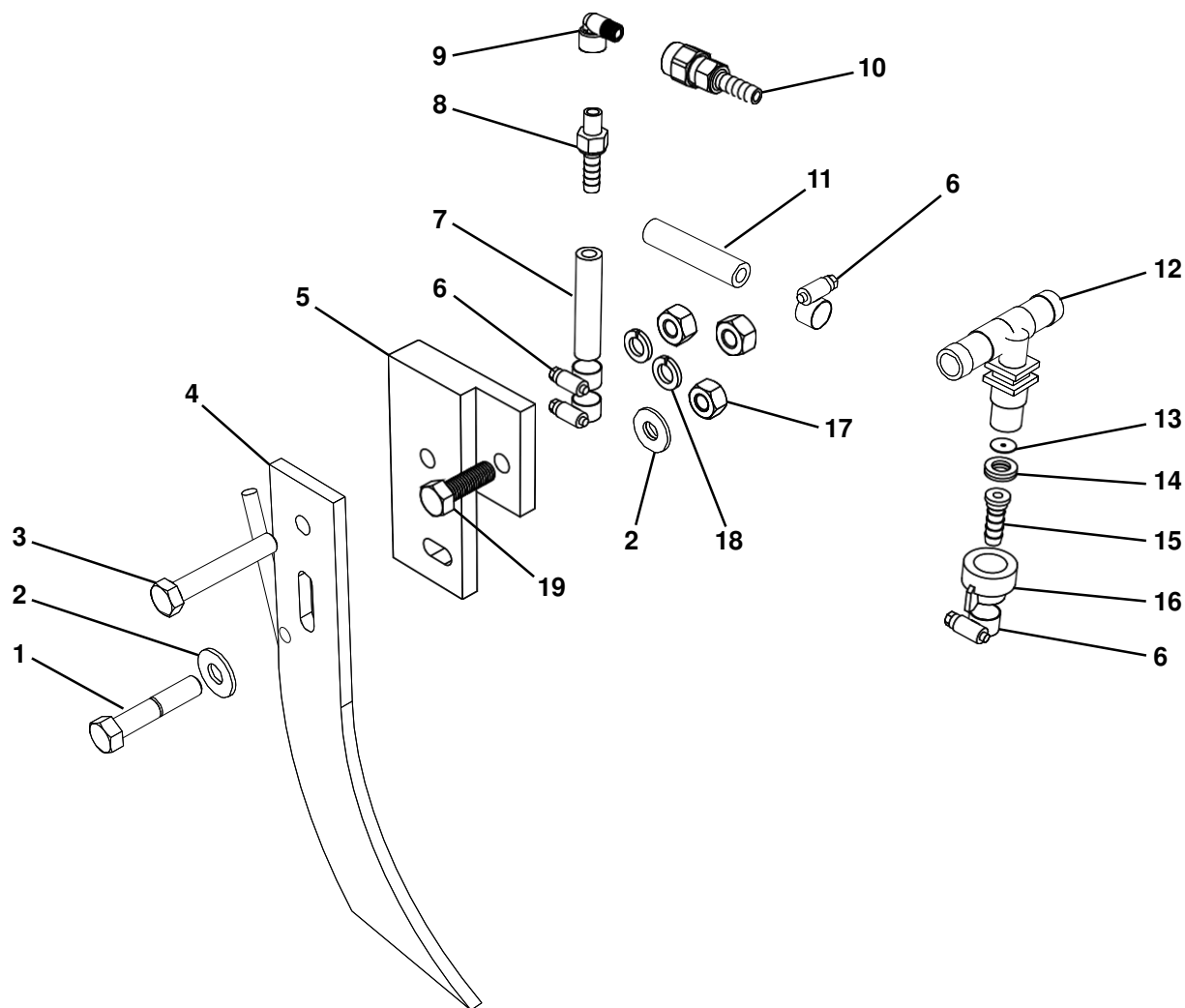

Item	Vendor Part#	Fast Part#	Description	Qty.
1		FBH0813	Bolt Hex Head 1/2 X 3-1/4 Zp Grade5	1
2		260	Washer Flat 1/2" Zp	2
3		155	Bolt Hex Head 1/2 X 2-1/2 Zp Grade5	1
4	WI-CO501000	750003	Wiese CO50100 Knife	1
5	CLN3934	750019	Mounting Bracket And Shim Kit	1
6	BR-64006H	540011	Clamp Hose 5/16"	4
7	BS-3/8BH200	510020	Hose EDPM 3/4" X 4"	1
8	VI-316A1438	530247	Hose Barb 1/4" MPT X 3/8" Hose	1
9	VI-304SE14	530246	Elbow Street 1/4" MPT	1
10	39188-8400-406-SS	530188	Valve Check 1/4" MPT X 3/8" Hose	1
11	BS-3/8BH200	510020	Hose EDPM 3/4" X 5/4"	1
12	18720-112-785-NYB	520004	Tee 3/4" Hose Barb	AR
NS	18719-111-785-NYB	520003	L 3/4" Hose Barb	AR
13	CP4916-XX	CP4916-XX	Orifice Disc 4916-XX See Rate Chart	1
14	CP18999EPR	590029	Gasket Orifice Disc	1
15	8400-406-NYB	590077	Hose Shank 3/8"	1
16	CP25607-1-NY	590076	Cap Nozzle Black	1
17		215	Nut Hex Head 1/2"	3
18		252	Washer Lock 1/2" Zp	3
19		603	Bolt Hex Head 1/2 X 1-3/4" Zp Grade 5	1

8118 3 Inch Quick fill

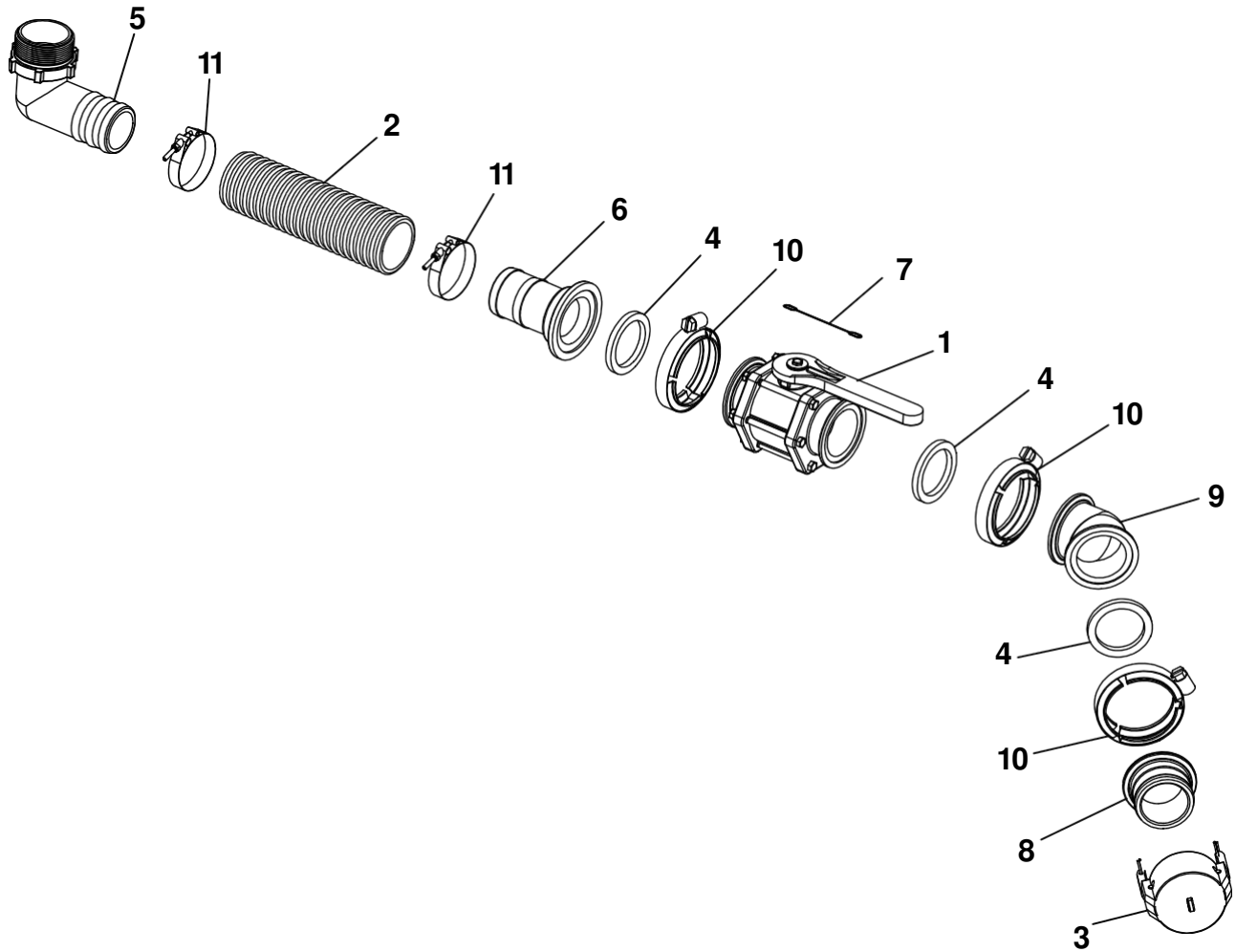

Item	Vendor Part#	Fast Part#	Description	Qty.
1	MV300CF	500042	Valve, 3" Manifold	1
2	AP12012810	510004	Hose, 3" Fertilizer	1
3	300Cap	530023	Cap, 3"	1
4	300G	530024	Gasket, 3" EPDM	3
5	HB300-90	530053	3" Hose Barb Elbow 90°	1
6	M300BRB	530113	3" Manifold X 3" Hose Barb	1
7	HN7912	530179	Lanyard	1
8	M300A	530233	3" Manifold X 3" Male Adapter	1
9	M300CPG45	530234	3" Manifold Coupler, 45°	1
10	FC300	540003	Clamp, 3"	3
11	TC343	540009	Clamp, 3" T Bolt	2

8118Applicator



8100 3 Inch Quick f III With Strainer

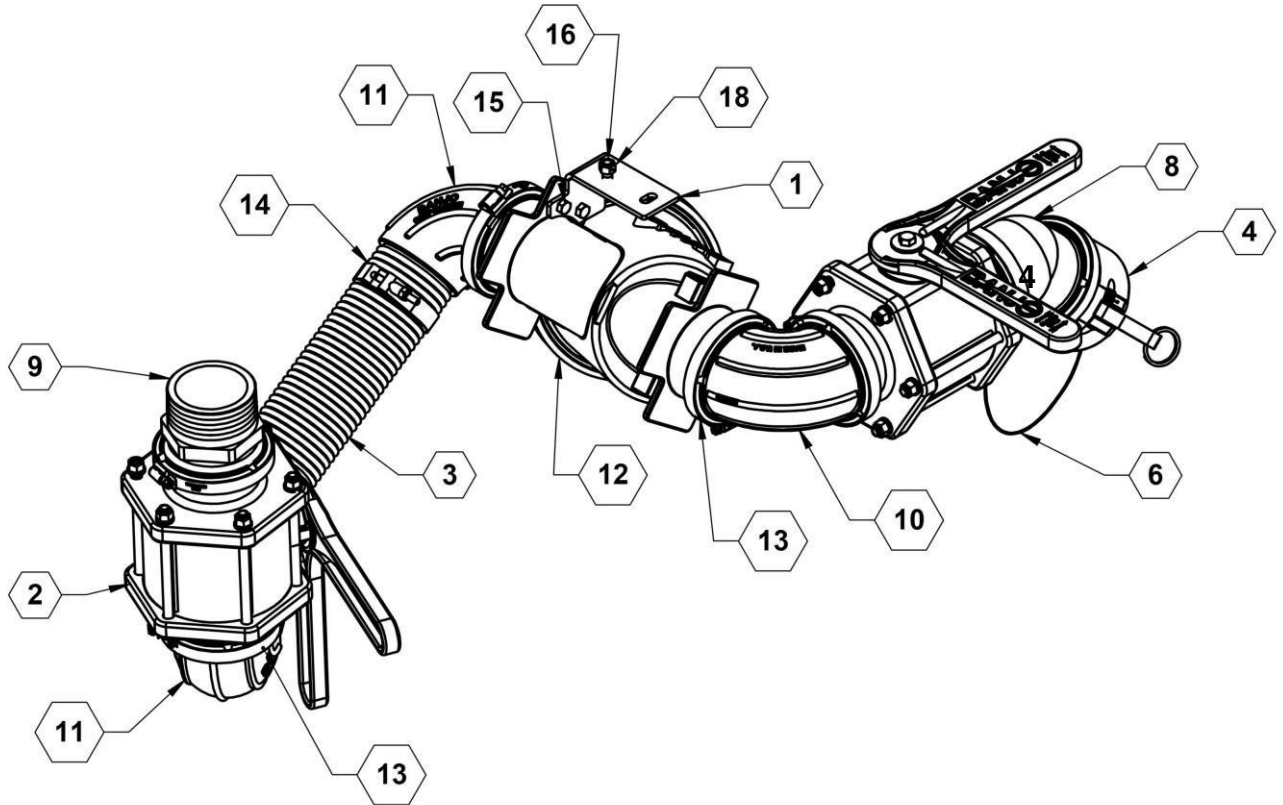

ITEM	PART NO.	QTY.	DESCRIPTION
1	28205	1	PLATE, 3" STRAINER MOUNT
2	500042	2	MANIFOLD VALVE, STD PORT 3"
3	510004	2	HOSE, 3" FERTILIZER
4	530023	1	CAP, 3"
5	530024	7	GASKET, 3" EPDM
6	530179	1	CABLE LANYARD
7	530233	1	MANIFOLD ADAPTER, 3" X 3" QDC MALE
8	530234	1	COUPLER, 3" X 45°
9	530385	1	COUPLING, 3" MANIFOLD X 3" MPT
10	530439	1	MANIFOLD SWEEP, FLANGE 3"
11	530441	2	FLANGE SWEEP, 90 X 3" HOSE BARB
12	530442	1	STRAINER, 3" Y STANDARD PORT -12
13	540003	7	CLAMP, WORM SCREW 3"
14	540027	2	CLAMP, HOSE 3" T-BOLT
15	596115M	2	BOLT, HH 5/16-18X1 GR5 MAGNI
16	596128M	1	BOLT, HH 3/8-16 X 1 GR5 MAGNI
17	596212M	2	NUT, HEX 5/16-18 MAGNI
18	596237M	1	NUT, CENTERLOCK 3/8-16 MAGNI
19	596257M	2	WASHER, FLAT 5/16 USS MAGNI
20	596258M	1	WASHER, FLAT 3/8 MAGNI

8118 t a n k t o P u m p P l u m B i n g

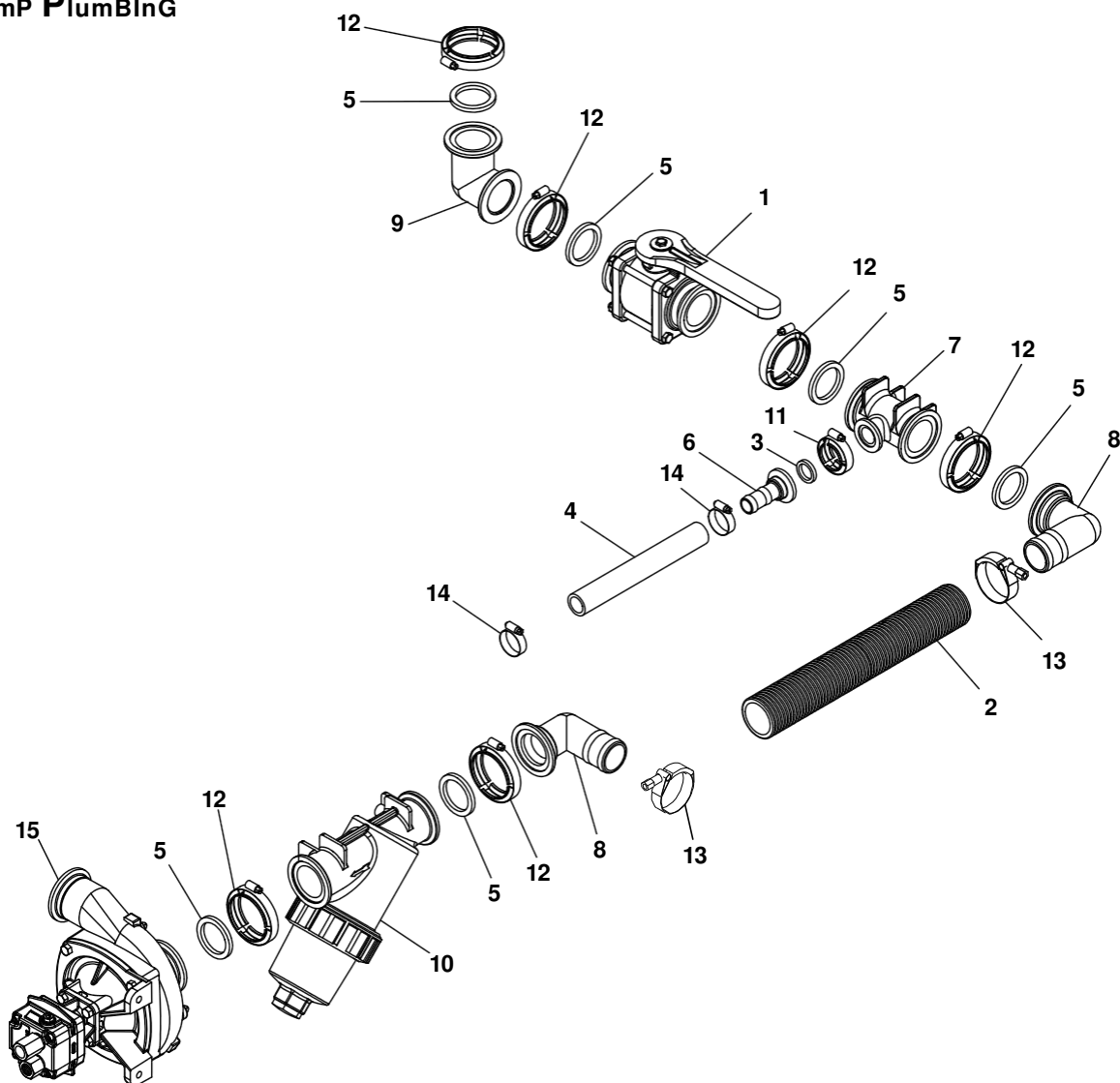

Item	Vendor Part#	Fast Part#	Description	Qty.
1	MV220CF	500006	Valve, 2" Full Port Manifold	1
2	AP12012805	510003	Hose, 2", Fertilizer	AR
3	100G	530013	Gasket, 1" EPDM	1
4	1BH200	510016	Hose, 1" EPDM	AR
5	200G	530019	Gasket, 2" EPDM	6
6	M100BRB	530066	1" Manifold X 1" Hose Barb	1
7	M220100TEE	530099	2" Full Port Manifold X 1" Flange Tee	1
8	M220BRB90	530104	2" Full Port Manifold X 2" Hose Barb 90°	2
9	M200CPG90	530106	2" Full Port Manifold Coupler, 90°	1
10	MLS22230	530125	2" Full Port Line Strainer	1
11	FC100	540000	Clamp, 1"	1
12	FC220	540002	Clamp, 2" Full Port	6
13	TC287	540008	Clamp, 2" T Bolt	2
14	64016H	540014	Clamp, 1"	2
15	9306C-HM1C-UB	550011	Pump, Hypro	AR
NS	FMC150FHYD206	550000	Pump, Ace, 150-204	AR
NS	FMC205FHYD304	550025	Pump, Ace, 205-304	AR
NS	M300220CPG	530316	3" Manifold Reducer X 2" Coupler	AR
NS	FC300	540003	Clamp, 3"	AR
NS	300G	530024	Gasket, 3" EPDM	AR

8118Applicator



HYPro Pump

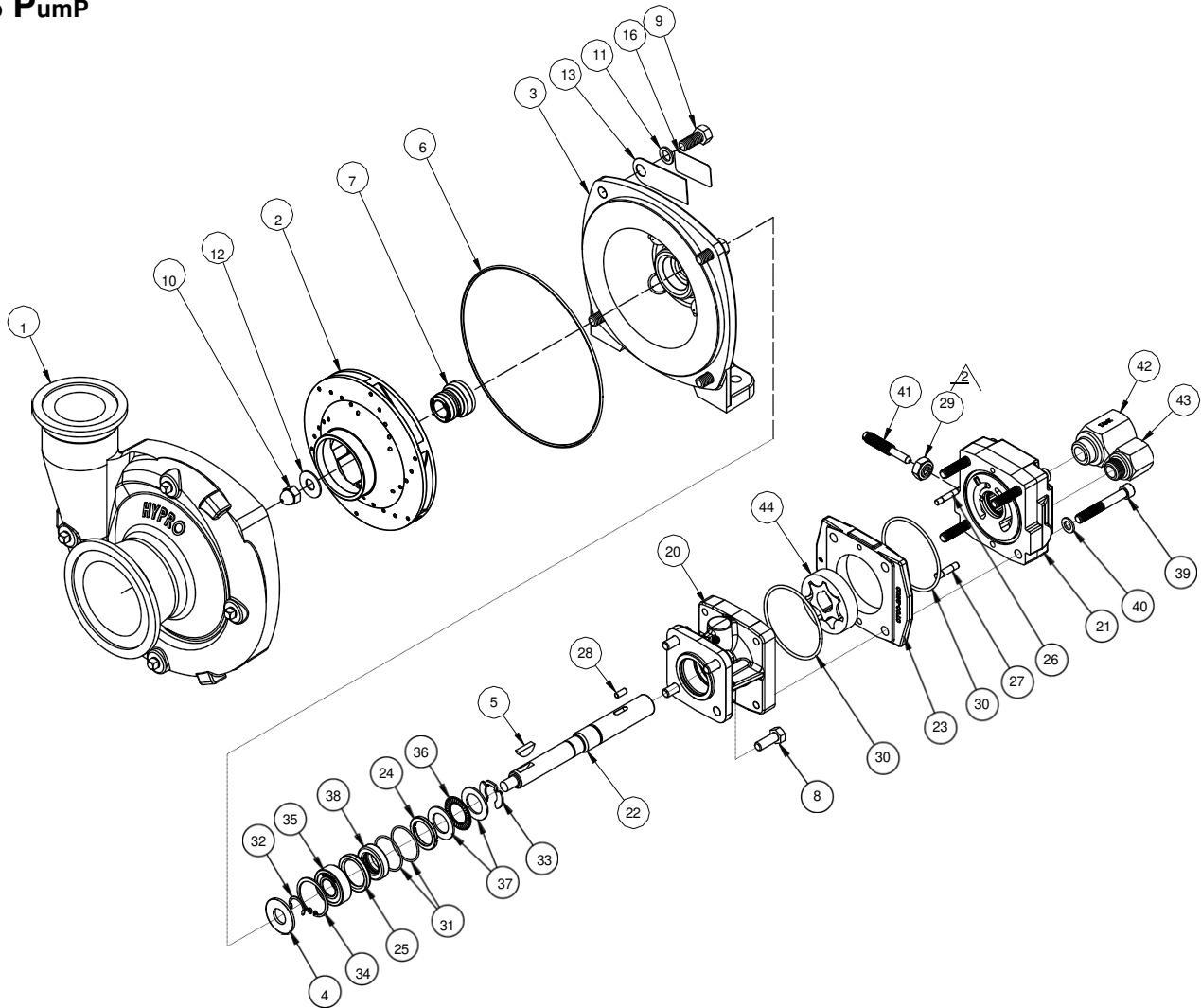

22	0533-2500	SHAFT	1	44	3900-0022	GEROTOR	1
21	0254-2500C2	ENDPLATEASSY	1	43	3360-0023A	ADAPTER-INLETPORTASSY	1
20	0150-2500C	BODYASSY-SMALLPILOT	1	42	3320-0052A	CHECKVALVEASSY- TANK PORT	1
19	6031-0373	CESTICKERLABEL	1	41	3220-0029	VALVESTEM	1
18	6031-0343	INSTRUCTIONTAG	1	40	2270-0039	WASHER,FLAT5/16"	4
17	6031-0340	LABELREADYFORROUNDUP	1	39	2220-0021	SCREW,SOCKETHEAD	4
16	6031-0325	DECAL	1	38	2104-0010	LIPSEAL	1
15	3435-0171	PACKINGKIT	1	37	2029-0010	BEARINGRACE,THRU	2
14	3031-0134	CARTON- INDIVIDUAL	1	36	2029-0009	BEARING,THRUST	1
13	2270-0076	TAG	1	35	2000-0010	BEARING,BALL	1
12	2270-0071	IMPELLERWASHER	1	34	1820-0013	INT. RET.RING	1
11	2270-0041	WASHER	1	33	1810-0026	RETAININGRING	1
10	2253-0002	ALCNUT0.3750-24-N	1	32	1810-0014	RETAININGRING	1
9	2210-0020	CAPSCREW,HEXHEAD3/8"-16 X 7/8"	4	31	1720-0268	O-RING	2
8	2210-0005	CAPSCREW,HEXHEAD5/16"-18 X 7/8"	4	30	1720-0110	O-RING	2
7	2120-0039	SEAL,MECHANICAL	1	29	1700-0245	NUT,SEALING	1
6	1720-0083	O-RING	1	28	1610-0031	HM1 & HM5 RoundKey	1
5	1610-0012	WOODRUFFKEY	1	27	1600-0044	DOWELPIN	1
4	1410-0056	SLINGERSEAL	1	26	1600-0037	DOWELPIN	1
3	0750-9300C2	MOUNTINGFLANGE	1	25	1410-0131	CARTRIDGE,FRONT	1
2	0401-9200P2	IMPELLER(CWROTATION)	1	24	1410-0130	SPACER,3L SEAL	1
1	0158-9200C	PUMP HOUSING, 300x220 U.FLG	1	23	0700-2500C1	GEROTORHOUSINGHM1, COATED	1
ITE M NO.	PART NUMBE R	DESCRIPTION	QTY	ITE M NO.	PART NUMBE R	DESCRIPTION	QTY.

Optional aCe 205 PumP motor

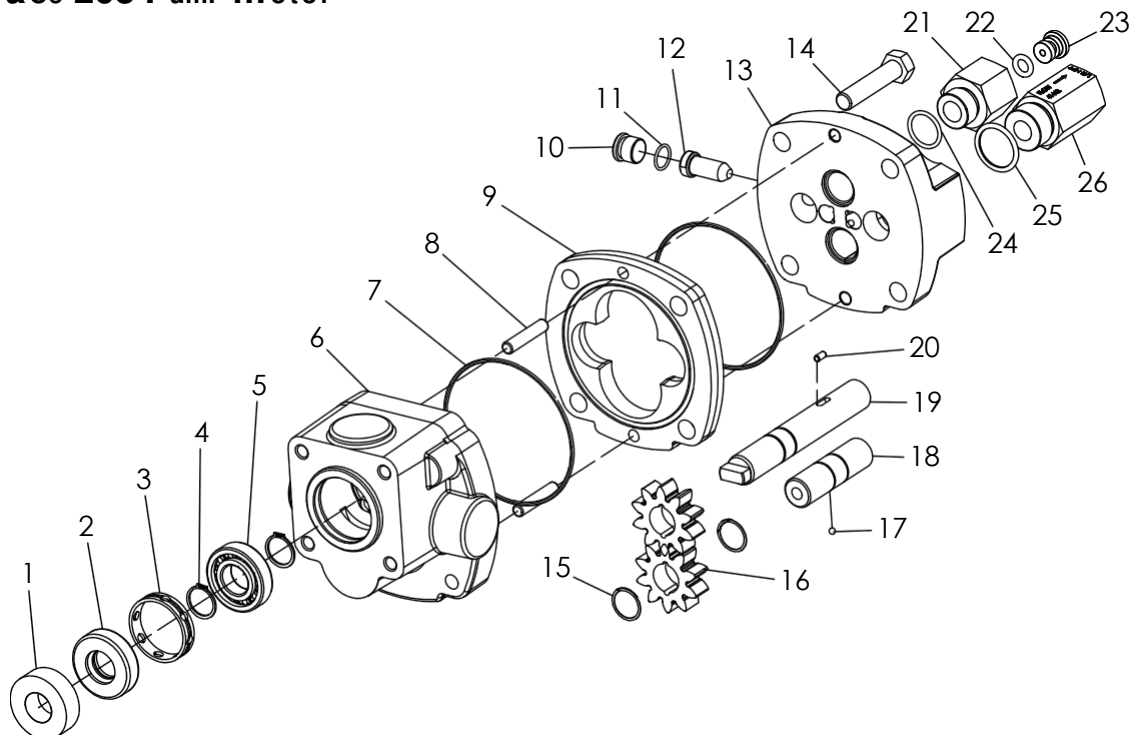

Item	Vendor Part#	Fast Part#	Description	Qty.
1	BAC-53	41110	Pipe Plug	4
1	41120	41120	Pipe Plug, Stainless Steel (Optional)	4
2	7AC-14-FLG-A	41535	Volute, 300 Standard Flange X 220 Full Port Flange	1
3	BAC-23-B-SS	40393	Nut, 3/8" Nf, Stainless Steel	1
4	BAC-24-B-SS	42702	Washer, 3/8", Stainless Steel, Self-Locking	1
5	BAC-26-200-P	40434	Impeller, With Extended Keyway, Thermoplastic	1
5	BAC-26-200-CI	40433	Impeller, With Extended Keyway, Cast Iron (Optional)	1
5	BAC-26-200-SS	40436	Impeller, With Extended Keyway, 316 Stainless Steel (Optional)	1
6 ¹	BAC-7SC-205V	40149	Seal, Silicon Carbide	1
7 ¹	BAC-4A	40005	O-Ring, Body Seal	1
8	BAC-14-205-HYD	40338	Mounting Frame For 205 Pump	1
9	40950	40950	Cap Screw, 3/8" NC X 3/4" Hex Head	4
9	40930	40930	Cap Screw, 3/8" NC X 3/4" Hex Head, Stainless Steel (Optional)	4
10	41330	41330	Cap Screw, 5/16" NC X 3/4" Hex Head, Motor To Pump	4
11	BAC-54	41130	Slinger	1
12	BACH-33	40820	Snap Ring, Internal, BAC-14-205 Mounting Frame	2
13	BACH-32-HD	40385	Snap Ring, External, BAC-6-205 Shaft	3
14	40880	40880	Ball Bearing, Sealed, BAC-6-205 Shaft	2
15	BAC-6-205-HYD-SS	40068	Shaft, Extended Keyway, Tang, Stainless Steel	1
16	BAC-25	40425	Key, 1/8" X 1/8" X 13/16", Extended Keyway	1
17	S305	40163	Seal Support Spacer For 205 Series Pump	1
18	BAC-75-HYD-304N	41343	Hydraulic Motor, 11 GPM, Effective 5/13	1
19	41875	41875	O-Ring, #8 SAE Fitting	1
20	41445	41445	O-Ring, #10 SAE Fitting	1
21	BAC-80-8SAE	41455	Body, Restrictor Orifice, #8 SAE X 1/2" NPT	1
22	41448	41448	O-Ring, Orifice Insert	1
23	BAC-79-8	41447	Orifice Insert, Restrictor Insert, 0.125	1
24	41442	41442	Reverse Check Assembly, #10 SAE X 1/2" NPT	1
25	LS-304N	41429	Flow Limiter (Optional)	1
1	RK-FMCSC-205	52705	Repair Kit For FMC-205 Pump With Silicon Carbide Shaft Seal	
#	RK-BAC-75-HYD-300-L	41362	Repair Kit For 300 Series Hydraulic Motor	

8118Applicator



Optional aCe 304 Pump

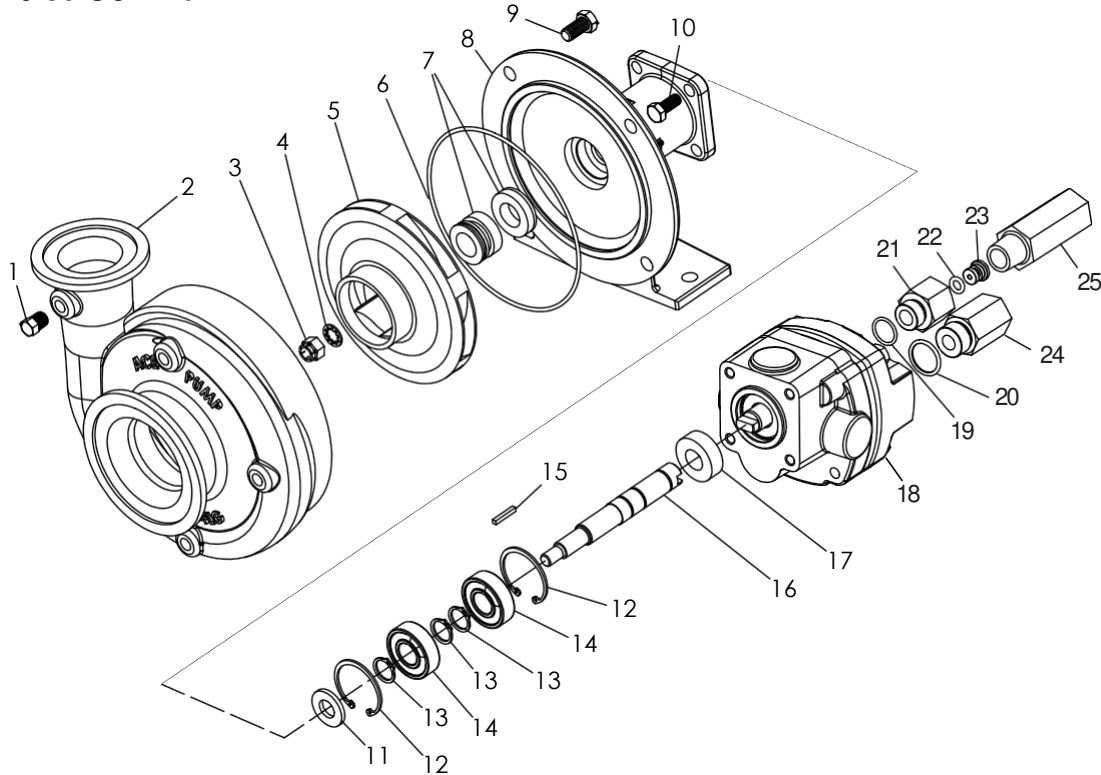

Item	Model304N	Model310N	Description	Qty.
1	40162	40162	Seal Support Spacer, S300 For 200 Series Pumps	1
1	40163	40163	Seal Support Spacer, S305 For 205 Series Pumps	1
2j	40154	40154	Seal Cartridge, BAC-75-300-TLS	1
3	43056	43056	Spacer Seal/Bearing, Perforated, 300 Series Motor	1
4	43205	43205	Retaining Ring, Bearing	2
5	43225	43225	Ball Bearing	1
6	43016	43016	DrivePlate	1
7j	43130	43130	O-Ring, Housing Seal	2
8	43085	43080	Dowel Pin, Housing	2
9	43005	43000	Gear Housing	1
10	43277	43277	Cap, Needle Valve With O-Ring, 300N Series Motor	1
11j	43276	43276	O-Ring, Needle ValveCap	1
12	43266	43266	Needle, 300N Series Motor	1
13	43022	43022	End Plate, 300N Series Motor	1
14	43185	43180	Cap Screw, 3/8" N.C. Hex Head	4
15	43240	43240	Retaining Ring, Gear	2
16	43035	43030	Gear	2
17	43250	43250	Ball, Idler Shaft	1
18	43235	43230	Idler Shaft	1
19	43046	43039	DriveShaft	1
20	43195	43190	Dowel Pin, DriveShaft	1
21	41455	41455	Body, Restrictor Orifice, #8 SAE x 1/2" NPT	1
22	41448		O-Ring, OrificeInsert	1
23	41447		Orifice Insert, Restrictor Insert	1
24	41875	41875	O-Ring, #8 SAE Fitting	1
25	41445	41445	O-Ring, #10 SAE Fitting	1
26	41442	41442	Reverse Check Assembly, #10 SAE x 1/2" NPT	1
j	41362	41362	Motor Repair Kit, includes 2, 7, 11	

Pump to Ball Valve

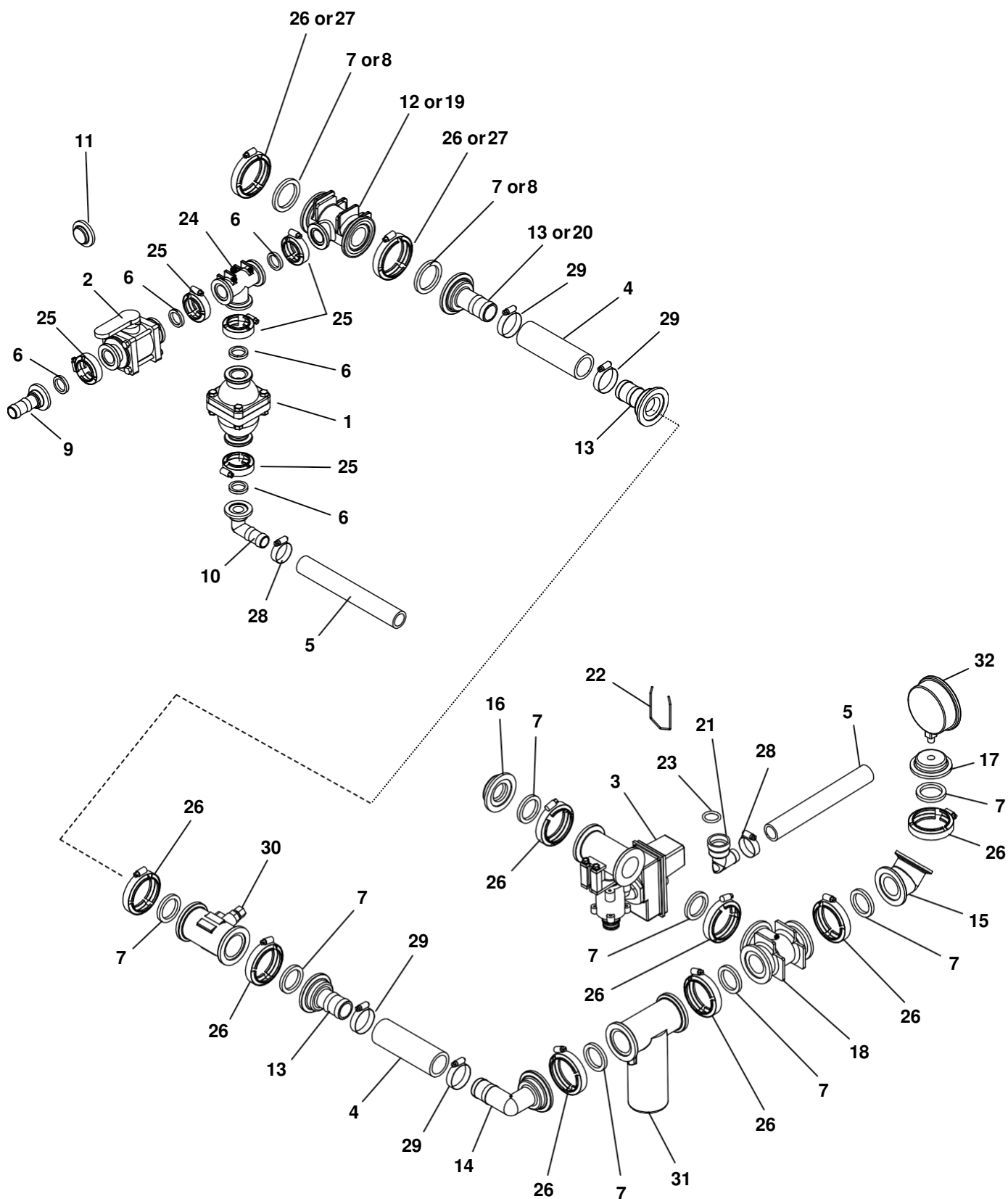

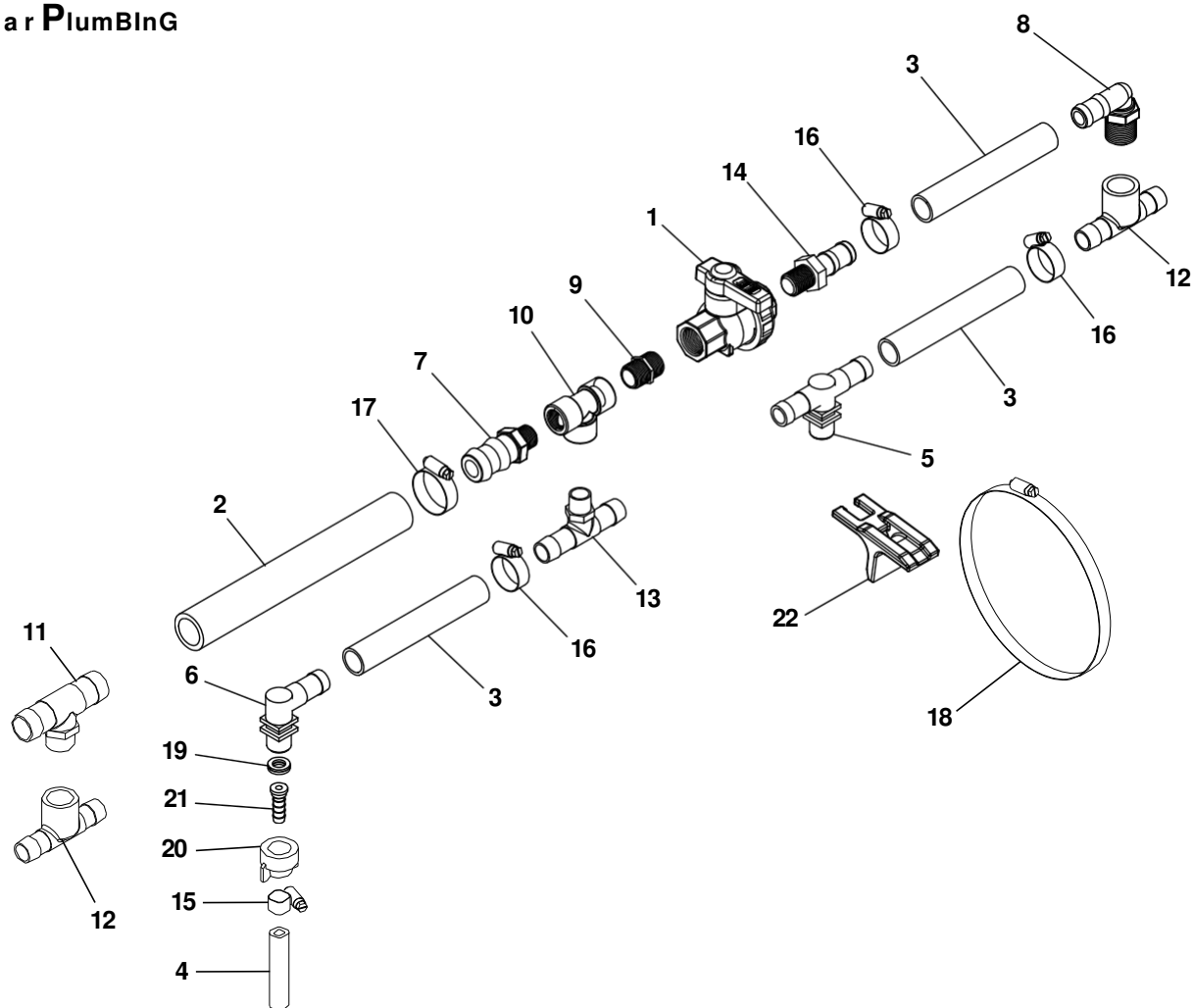

Item	Vendor Part#	Fast Part#	Description	Qty.
1	UV075FP	500043	Valve, 3/4"	AR
2	IBH200	510016	Hose 1" EDPM	AR
3	3/4BH200	510019	Hose, 3/4", EPDM	AR
4	3/8BH200	510020	Hose, 3/8", EPDM	AR
5	TJ18720111785NYB	520004	Nozzle, Double	AR
6	18719111785NYB	520003	Nozzle, Single	AR
7	HB075100	530039	3/4" MPT X 1" Hose Barb	AR
8	HB075-90	530040	3/4" MPT X 3/4" Hose Barb 90°	AR
9	NIP075-SH	530131	3/4" MPT Short Nipple	AR
10	TE075	530156	3/4" FPT Poly Tee	AR
11	T34100T	530181	3/4" MPT X 1" Hose Barb Tee	AR
12	3T34F	530220	3/4" FPT X 3/4" Hose Barb Tee	AR
13	3T34T	530221	3/4" MPT X 3/4" Hose Barb Tee	AR
14	HB075	530230	3/4" MPT X 3/4" Hose Barb	AR
15	640006H	540011	Clamp, 3/8"	AR
16	64012H	540013	Clamp, 3/4"	AR
17	64016H	540014	Clamp, 1"	AR
18	HCLSS18	540050	Clamp, 4 1/8 - 7"	AR
19	CP18999EPR	590029	Seal, EPDM	AR
20	CP256071NY	590076	Cap	AR
21	8400406NYB	590077	Connector, Hose Barb	AR
22		590187	Mount, Plumbing	AR

RaVen sCS450 Console

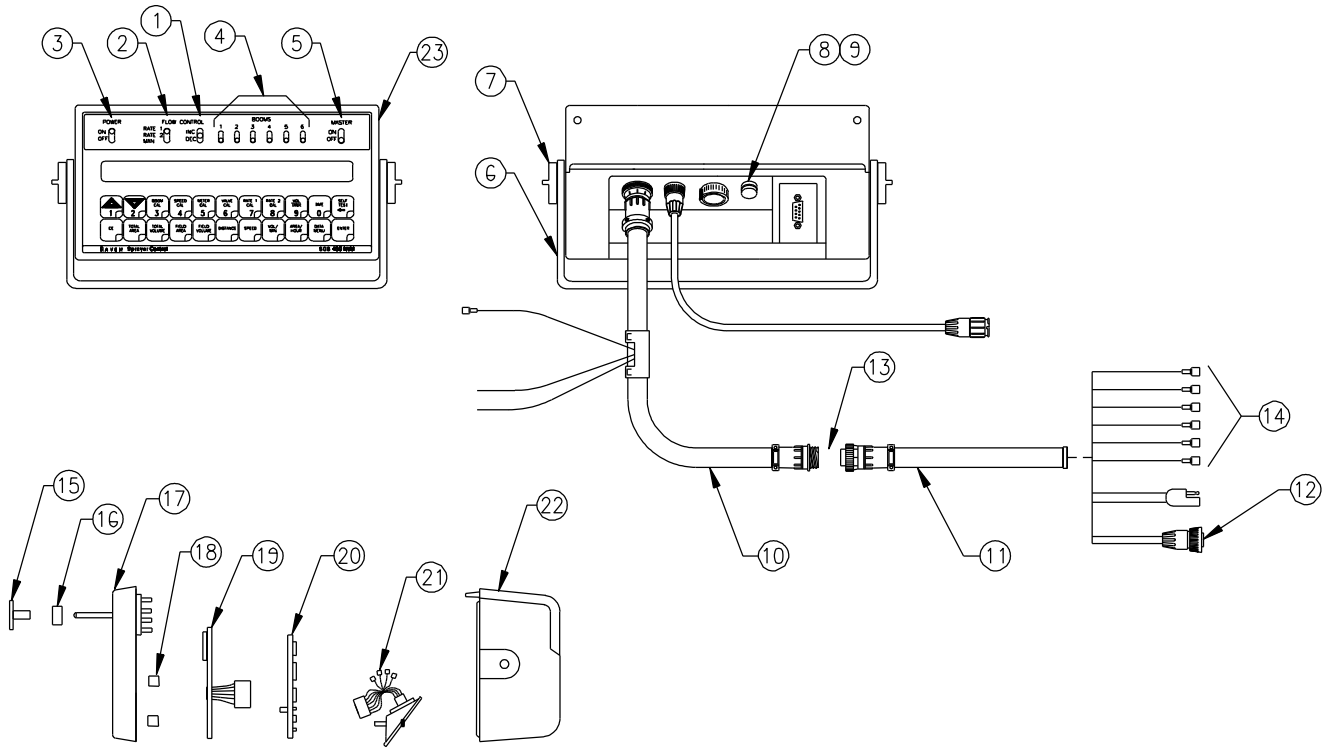

ITEM	DESCRIPTION	RAVEN PART #
1	Manual Adj. Switch	412-2011-049
2	Rate1/Rate2/ManualSwitch	019-0159-078
3	PowerSwitch	412-2011-048
4	Boom Switch	412-2003-010
5	Master Switch	412-2011-046
6	MountingBracket	106-0159-437
7	MountingKnob	106-0159-438
8	FuseHolder	510-2001-018
9	Fuse, 15Amp.	510-1003-003
10	Console Control Cable (10 ft.)	115-0159-492
	Console Control Cable (3 ft.)	115-0159-707
11	Flow Control Cable (6 ft.)	115-0159-495
	Flow Control Cable (12 ft.)	115-0159-496
	Flow Control Cable (24 ft.)	115-0159-708
12	Flow Meter Cable Ext. (6 ft.)	115-0159-016
	Flow Meter Cable Ext. (12 ft.)	115-0159-017
13	Flow Ext. Cable (12 ft.)	115-0159-493
	Flow Ext. Cable (24 ft.)	115-0159-494
14	AssortedTerminalKit	117-0159-402
15	SwitchCover	063-0159-734
16	1-Set Filler Spacers	117-0159-421
17	Face Plate Assembly	063-0172-024
18	Display Board Spacer	107-0159-478
19	LCD Display Board	063-0171-961
20	Processor Board (Serial Interface)	064-0159-745
21	Connector Plate Assembly (Serial Interface)	063-0172-022
22	Back Assembly	063-0159-530
23	SCS 450 Console (Serial Interface)	063-0171-220

Control Console harness - 155-0171-085

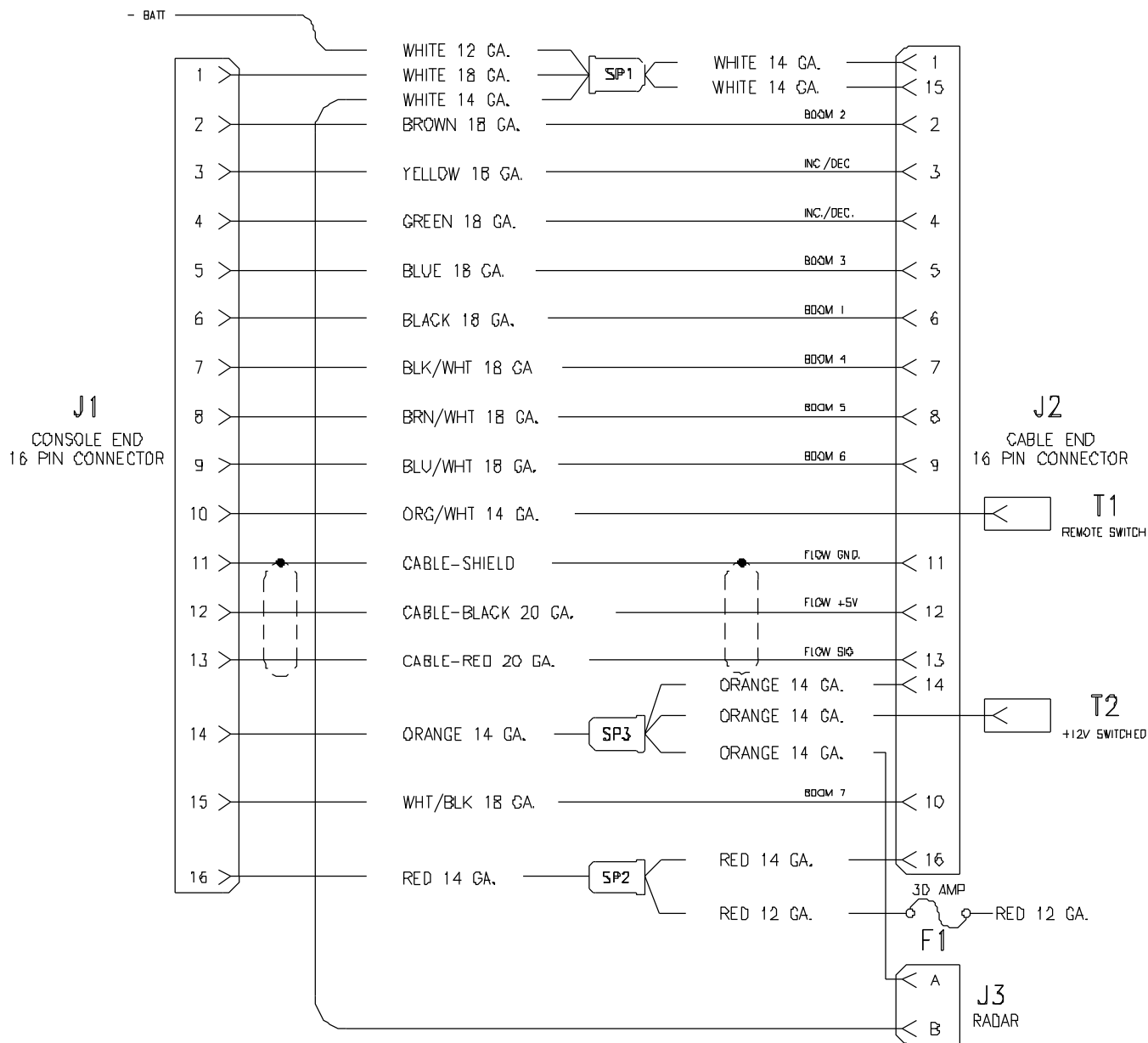

Control Console harness - 155-0159-856

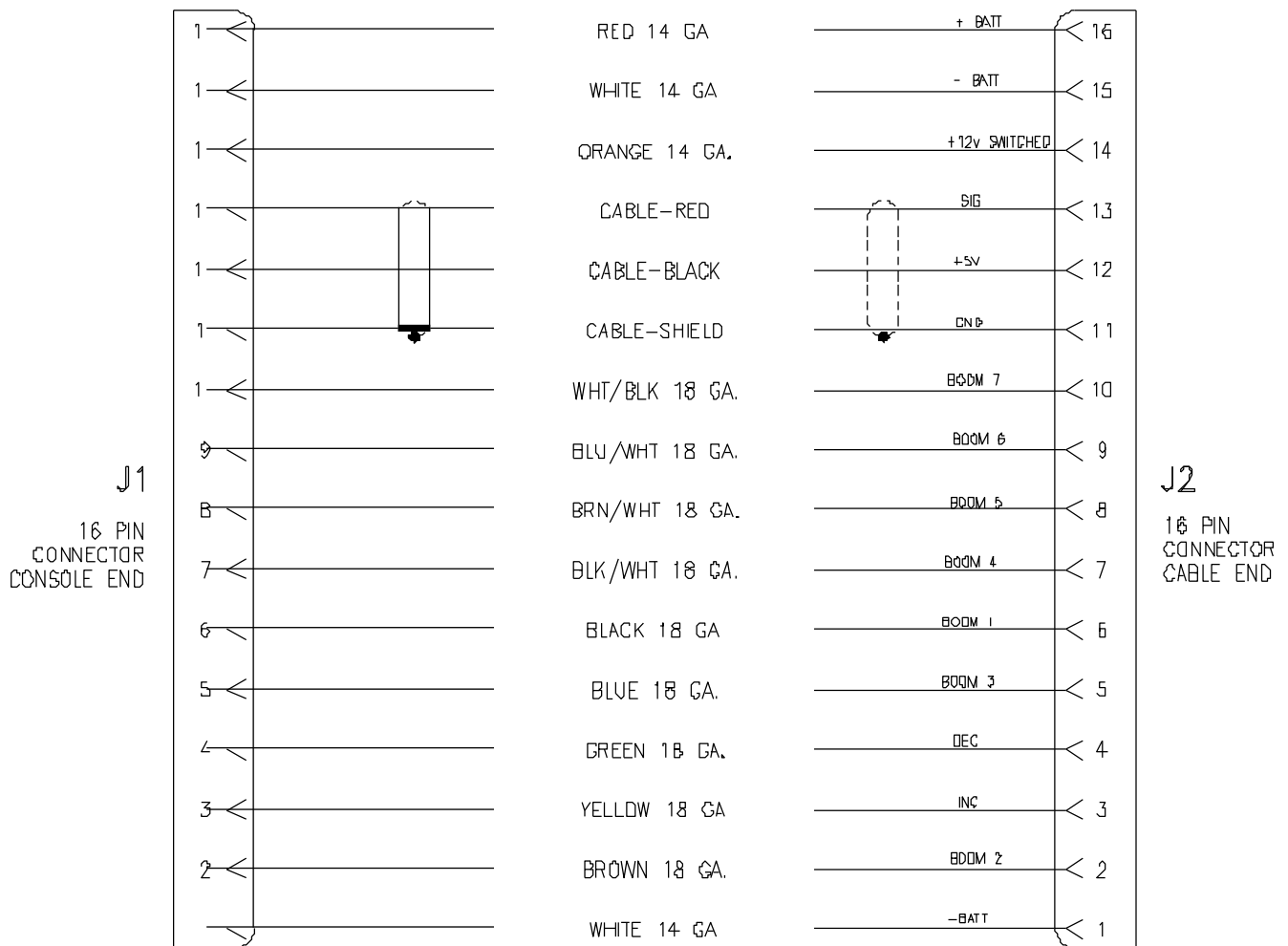

Control Console harness - 155-0171-086

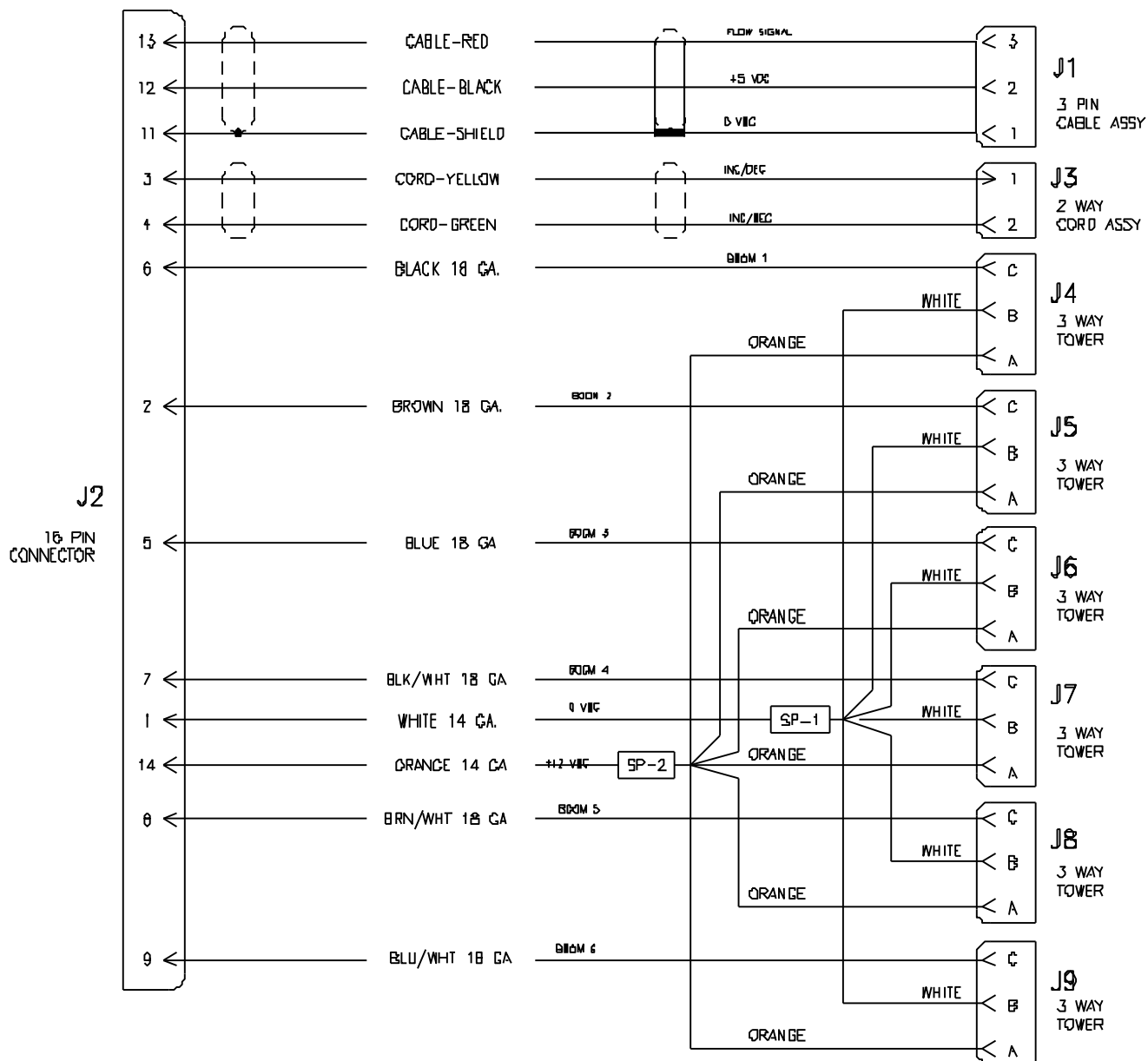

8118Applicator



hYdraulic SyStem for Pump

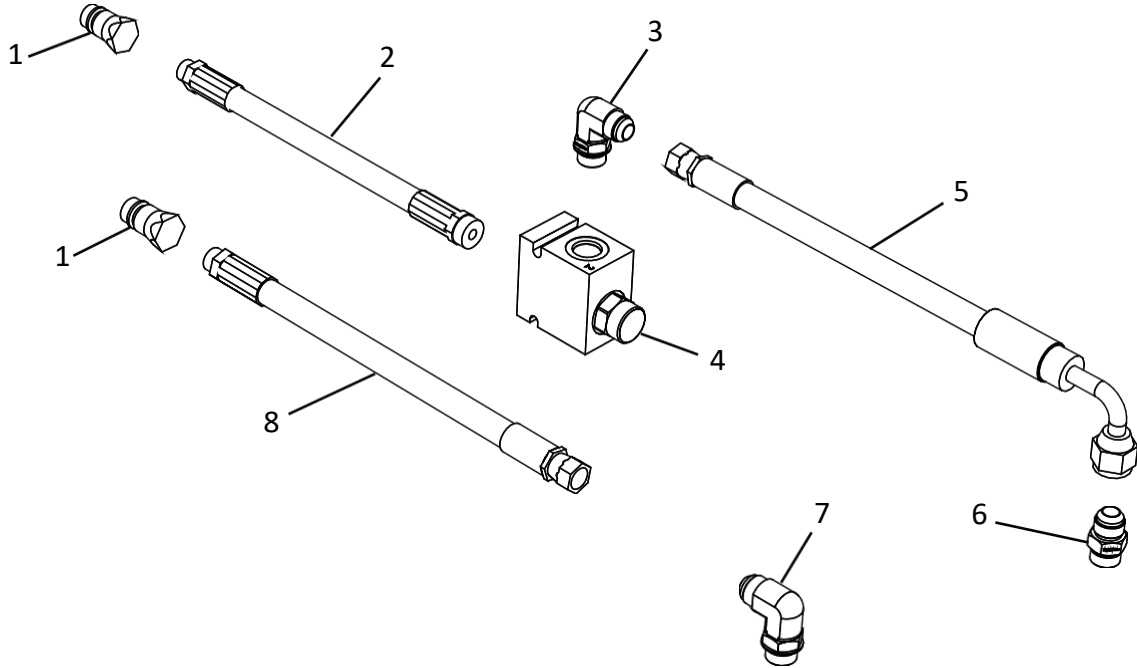

Item	Vendor Part#	Fast Part#	Description	Qty.
1		2-NV12-12SAE	Hose Tip	2
2		PA600054-1	Hose Pressure ToValve	1
3	TO6801-8-10	610086	Hyd Fitting 6801-8-10	1
4		610099	PC Valve 13GPM	1
5		PA600054-2	Hose Pressure ToPump	1
6	TO6400-10-10	610106	Hyd Fitting 6400-10-10	1
7	TO6801-10-10	610102	Hyd Fitting 6801-10-10	1
8		PA600053-3	Hose Pump Return	1

hYdrauLIc SCHEMATIC

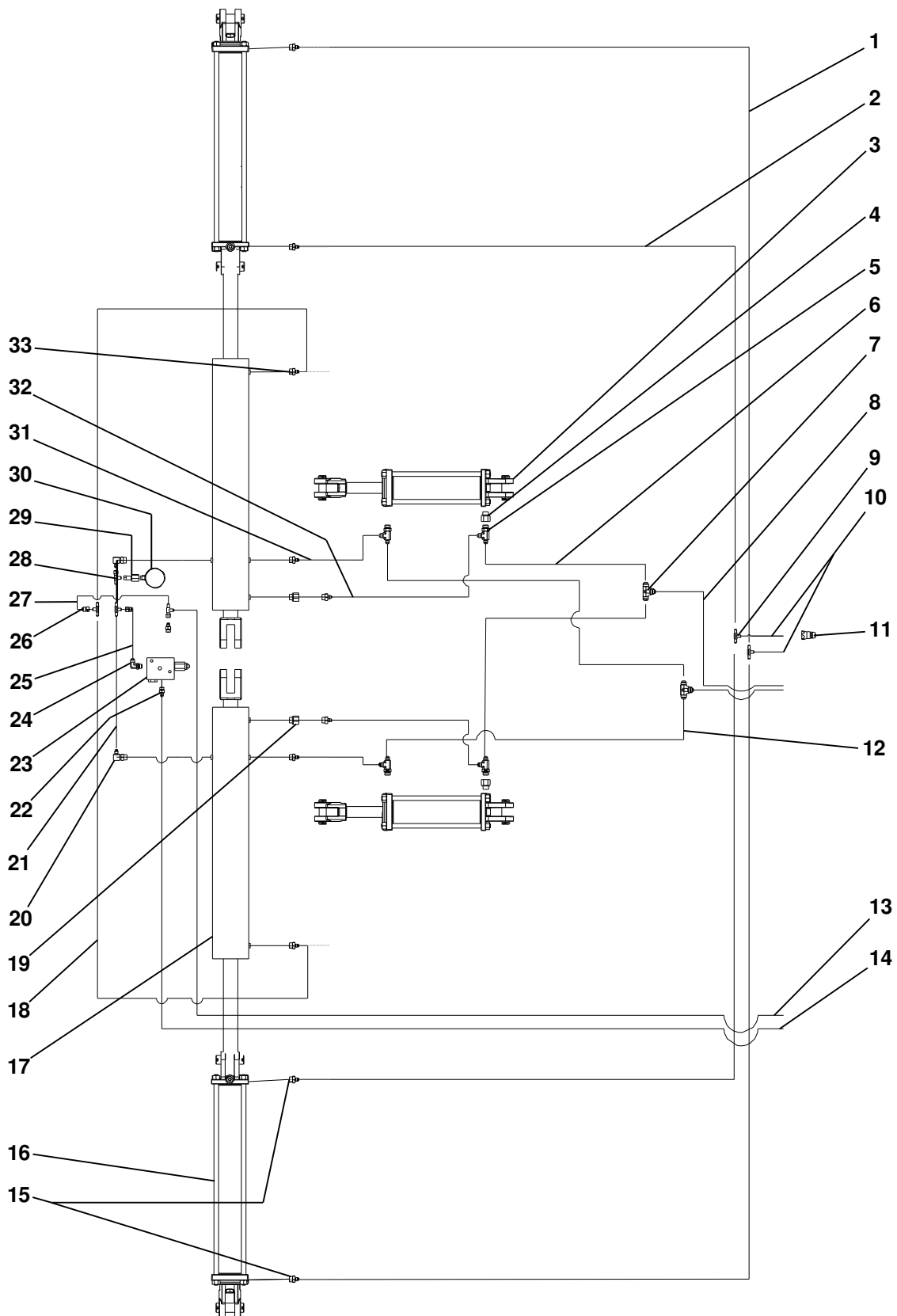

8118Applicator



Kit Contents

Item	Fast Part#	Description	Injector Quantity	Knife Quantity
	520003	3 Nozzle, Single Hose Shank NYB3		2
	520004	Nozzle, Double Hose Shank NYB		2
	520005	Nozzle, Single HS Conn 1/4" F	2	
	520006	Nozzle, Double HS Conn 1/4" F	2	3
	520014	Nozzle, SS 1/4" Tee	1	
	520015	Nozzle, SCA	1	
	520034	Tip, SS - 0015 Teejet	2	
	530001	1/4" X 1/4" Male Connector	1	1
	530014	1-1/2" EDPM Gasket	2	2
	530019	2" EDPM Gasket	2	2
	530024	3" EDPM Gasket	2	2
	530188	Hose Shank Assembly	1	
	530201	Barb Hose 1/4" X 3/8"	4	
	530218	3/8" X 3/8" Hose Mender W/ Stop	2	
	530236	Nipple: 1/4" MPT X 6" MPT	1	
	530246	Str. Elb: 1/4" MPT X 1/4" FPT	1	
	540001	Clamp, 2" Std Worm Screw	1	1
	540002	Clamp, 2" Full Worm Screw	1	1
	540003	Clamp, 3" Worm Screw	1	1
	540006	Clamp 1-1/2" T-Bolt Hose 1.81"	2	2
	540013	Clamp, Stainless 3/4" #12	10	5
	540014	Clamp, Stainless 1" #16		4
	540032	Clamp, Hose 5/16"	4	
	590029	Seal, EDPM Rubber		3
	590030	Cap Q.T. Ny.Lt. Yellow		3
	590031	Plate Orifice, Stainless Steel		3
	750008	Locking Collar, Std 30 Degrees	2	2
	750016	Rock Guard With Pin	1	
	750018	3/8 X 1/2" Set Screw, SS	2	
	750019	Mounting Bracket F/Wiese CO-50 Knife		1
	790041	20" Deep Grab & Go Toolbox	1	1
	AC40015	O-Ring, Volute Seal		1
	AC40151	Seal, 5/8" Shaft, Viton-C		1
	AC52700	Repair Kit	1	
	AP44103202	1/4 X 1/4" Union Connector	3	3
	AP44103240	1/4 X 1/4" Female Adaptor	1	1
	AXGC30020XXL	XXL Green Gloves	1	1
	LAXNVGOGGLES	Goggles	1	1
	BJ200SHIM	2" Shim		2
	BJHM075	3/4" X 3/4" Hose Barb	2	2
	BJHM100	1" X 1" Hose Barb	2	2
	BJHM150	1-1/2" X 1-1/2" Hose Barb	1	1
	CLFBS1004	5/8 X 1 Square Head Set Screw	2	
	PL707TB	Reduran	1	1
	WA21047	Cable Tie, 15" Heavy Duty	20	20
	VI3K9438	Barb: 3/8" HB For 8027 Nut-Poly		3

Lighting

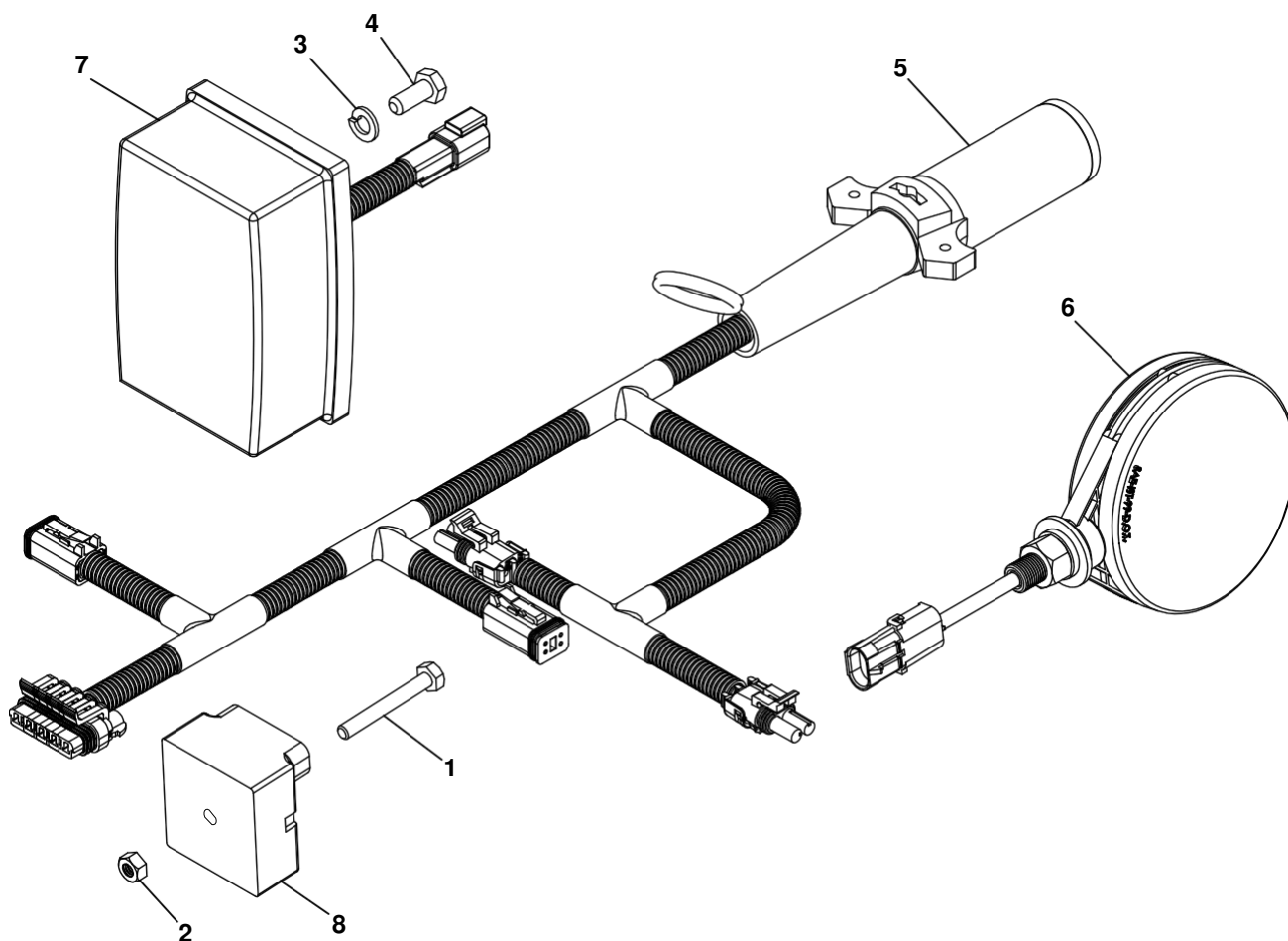

Item	Vendor Part#	Fast Part#	Description	Qty.
1		104	Bolt, 1/4 x 2" Grade 5Zp	1
2		235	Nut, Centerlock, 1/4" Zp	1
3		249	Washer, Lock, 5/16" Zp	4
4		590229	Bolt, 8 X 20 mm 8.8 Zp	4
5		740023	Applicator Light Wiring Harness	1
6		740024	Amber WarningLight	2
7		740025	Red TailLight	2
8		740031	Light Module	1



Notes



**Fast Global Solutions
4130 Commerce Boulevard
Windom, MN 56101**

**1-800-772-9279 Toll Free
1-507-427-3861 Voice
1-507-427-3030 Fax**