

FAST™

PARTS MANUAL

AG SOLUTIONS

813P / 833P Liquid Fertilizer Applicator



FAST GLOBAL SOLUTIONS



ILLUSTRATED PARTS LIST

Limited Warranty

FAST GLOBAL SOLUTIONS warrants to the buyer that the new machinery is free from defects in material and workmanship.

This warranty is only effective as to any new machinery which has not been altered, changed, repaired or treated since its delivery to the buyer, other than by FAST AG Solutions or its authorized dealers or employees, and does not apply to accessories, attachments, tools or parts, sold or operated with the new machinery, if they have not been manufactured by FAST GLOBAL SOLUTIONS.

FAST GLOBAL SOLUTIONS shall only be liable for defects in the materials or workmanship attributable to faulty material or bad workmanship that can be proved by the buyer, and specifically excludes liability for repairs arising as a result of normal wear and tear of the new machinery or in any other manner whatsoever, and without limiting the generality of the foregoing, excludes application or installation of parts not completed in accordance with this operator's manual, specifications, or printed instructions.

Written notice shall be given by registered mail, to the Manufacturer within seven (7) days after the defect shall have become apparent or the repairs shall have become necessary, addressed as follows:

FAST GLOBAL SOLUTIONS
4130 Commerce Boulevard
Windom, MN 56101

This warranty shall expire one (1) year after the date of delivery of the new machinery.

If these conditions are fulfilled, FAST GLOBAL SOLUTIONS shall at its own cost and at its own option either repair or replace any defective parts provided that the buyer shall be responsible for all expenses incurred as a result of repairs, labor, parts, transportation or any other work, unless FAST GLOBAL SOLUTIONS has authorized such expenses in advance.

The warranty shall not extend to any repairs, changes, alterations, or replacements made to the new equipment other than by FAST GLOBAL SOLUTIONS or its authorized dealers or employees.

This warranty extends only to the original owner of the new equipment.

Rubber parts (including tires, hoses, grommets) are not warranted.

This warranty is limited to the terms stated herein and is in lieu of any other warranties whether express or implied, and without limiting the generality of the foregoing, excluded all warranties, express or implied or conditions whether statutory or otherwise as to quality and fitness for any purpose of the new equipment. the Manufacturer disclaims all liability for incidental or consequential damages.

This Applicator is subject to design changes and FAST GLOBAL SOLUTIONS shall not be required to retrofit or exchange items on previously sold units except at its own option.

Warranty void if not registered.



ILLUSTRATED PARTS LIST

FAST LIQUID FERTILIZER APPLICATOR

Warranty Registration Form & Inspection Report

Warranty Registration

This form must be filled out by the dealer and signed by both the dealer and the customer at the time of delivery.

Customer Name				
Address				
City		State		Zip
Phone				
Dealer Name				
Address				
City		State		Zip
Applicator Model				
Serial Number				
Delivery Date				

DEALER INSPECTION REPORT

- All Fasteners Tight
- Wheel Bolts Torqued
- Hydraulic Hoses and Fittings Free and Tight
- Fertilizer Hoses and Fittings Free and Tight
- Wheel Drive Turns Freely
- Lubricate Machine
- Check Tire Pressure
- Frame and Wings Level
- Monitors and Controllers Function
- Wiring Harness Connected

SAFETY

- Safety Chain Installed
- All Guards Installed
- All Safety Signs Installed
- Reflectors, SMV and Lights Clean
- Review Operating and Safety Instructions

I have thoroughly instructed the buyer on the above described equipment which review included the Operator's Manual content, equipment care, adjustments, safe operation and applicable warranty policy.

Date _____

Dealer's Rep. Signature _____

The above equipment and Operator's Manual have been received by me and I have been thoroughly instructed as to care, adjustments, safe operation and applicable warranty policy.

Date _____

Owner's Signature _____

White - Amity by FAST
Yellow - Dealer
Pink - Customer



ILLUSTRATED PARTS LIST

FAST 813P / 833P Series Applicator

APPLICATOR SERIAL NUMBER _____

DATE PURCHASED _____ / _____ / _____

NUMBER OF COULTERS _____

PUMP MANUFACTURER:

(CIRCLE ONE)

ACE 150F-206F

ACE 205F-304

Hypro 9306C-HMIC-MB



FAST GLOBAL
SOLUTIONS



General Information

All rights, especially copying and distribution rights are reserved. No part of this publication may be reproduced in any form or by any means, electronic or mechanical, including photocopying, without express written permission from FAST AG Solutions.

Parts information in this manual represents components installed when product was manufactured based upon the best available information. Modifications made subsequent to initial delivery are not included. Always verify the parts and color required when ordering parts.

If you have any questions, please contact your FAST AG Solutions Parts and Service Department.

Parts Ordering Guide

1. Provide the Serial Number of your Chassis or System when ordering.
2. Use the Part Number and Description when ordering parts.
3. Provide the Page Title and Page Number if required.

Parts Searching Guide

To search this PDF by keyword, name, description or part number, use **ctrl + f** for simple searches or **ctrl + shift + f** for advanced searches.

Explanation of Parts Lists

The parts lists are broken down sub assemblies and listed in 4 columns:

- **ITEM** - These numbers are found on the illustration associated with the parts list.
- **NS** - This item is NOT SHOWN, included for reference.
- **QTY.** - This is the quantity of parts needed in an assembly.
- **AR** - The quantity of this item is AS REQUIRED for the location.
- **PART NO.** - These are the part numbers associated to the ITEM.
- **DESCRIPTION** - This is the description of the part.



ILLUSTRATED PARTS LIST

Table of Contents

Section	Page
General Information	6
Rear Hitch	8
833P Center, Inner and Outer Wing Section	10
813P Center Section	12
813P Inner and Outer Wing Section	14
Gauge Wheel	16
Q736 Hub Assembly, 5 Bolt	18
Mounting Clamp Kit for Auscherman Coulter Option	20
Auscherman Vantage II Coulter	22
Clymer Coulter Assembly	24
Knife Assembly	26
AP Coulter Row Unit Base Assembly	28
AP Coulter Row Unit Cast Coulter Assembly	30
N669 Complete Hub W/ Square Hole w/ Triple Seal Assembly	32
AP Coulter Upper Casting Mounts	34
FAST AP Coulter Injection Option Assembly	36
DeFender® for Injection Assembly	38
AP Coulter Knife Option Assembly	40
Coulter Decal Assembly	42
Ace 150-206 Pump Hydraulic Motor	44
Ace 150-206 Pump	45
Ace 304 Pump	46
ACE 150-206 Pump, Self Priming	48
Hypro Pump	50
Ball Valve Mount	52
Toolbar Plumbing	54
Raven Components	55
Control Harness 155-0171-085	56
Control Harness 155-0159-856	57
Control Harness 155-0171-086	58
Hydraulic System for Pump	59
813P Hydraulic System	60
833P Hydraulic System	62
813P Hydraulic Schematic	64
833P Hydraulic Schematic	66
Lighting	68

Rear Hitch

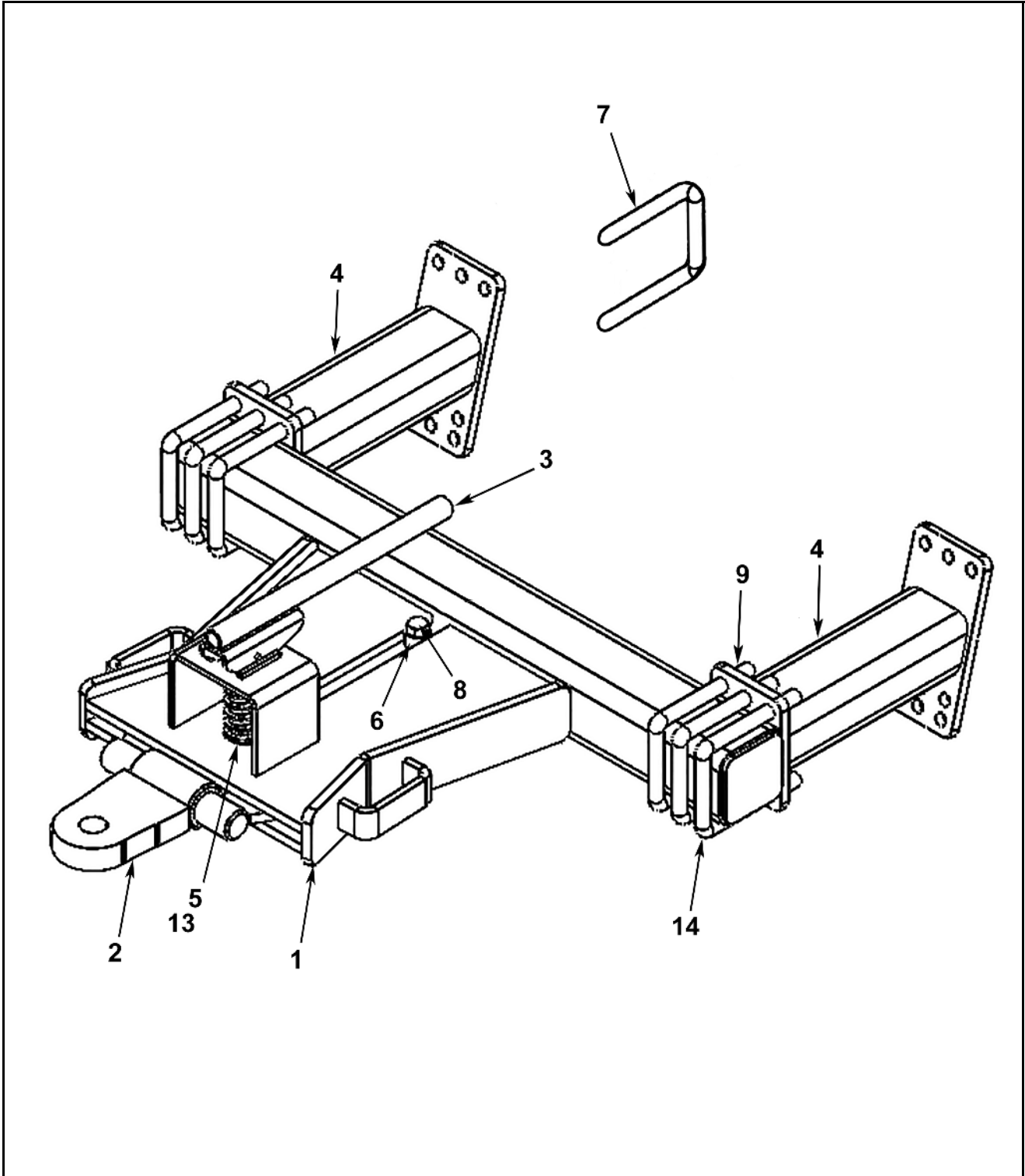



ILLUSTRATED PARTS LIST

Rear Hitch Parts List

ITEM	PART NO.	QTY.	DESCRIPTION
1	17851	1	HITCH, BOLT ON BASE
2	17852	1	SLIDER HITCH WELDMENT
3	17853	1	HANDLE, PIN LIFT
4	17854	2	EXTENSION, HITCH
5	17855	1	PIN, 7.00 LONG
6	17871	2	DOM, SPACER
7	17873	6	5/8" U-BOLT, 4 X 6 (813P)
7	590075	6	5/8" U-BOLT, 4 X 6, MAGNI (813P)
7	590108	6	5/8" U-BOLT, 7 X 7, MAGNI (833P)
8	596171M	1	HBOLT 0.6250-11 X 2.5 X 1.5-N
9	596216M	13	NUT. HEX, 5/8-11 MAGNI
10	709	1	PIN, SPRING, 3/4 X 2-1/2 ZP
11	790	1	BUSHING, MACH NR 1-1/4 X 10 GA
12	COTTER PIN	1	COTTER PIN 1/4" X 2-3/4
13	590195	1	SPRING, 4"
14	590186	6	3/4" U-BOLT, 4 X 5

833P Center, Inner and Outer Wing Section

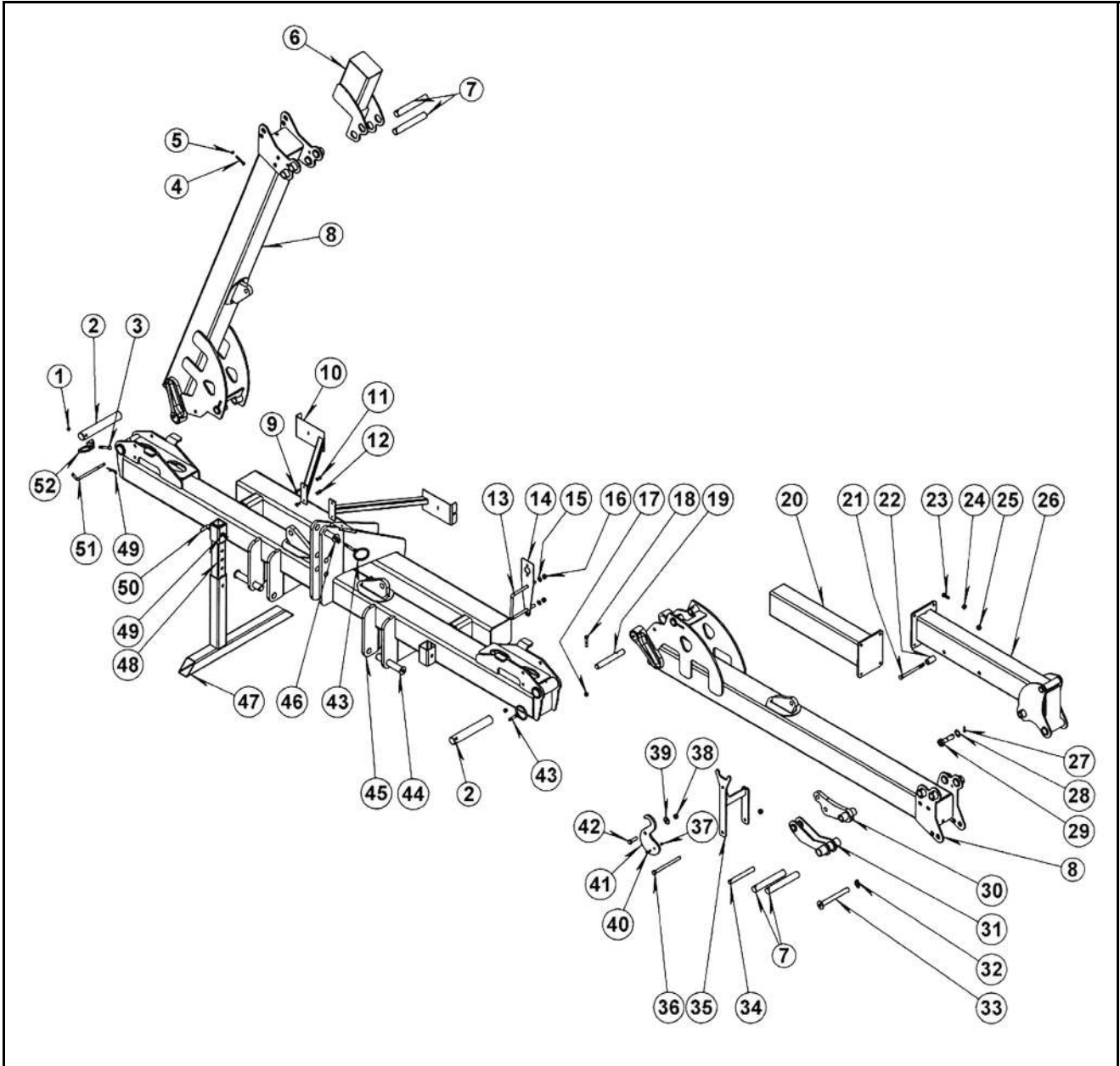



ILLUSTRATED PARTS LIST

833P Center, Inner and Outer Wing Section Parts List

		PARTS BY # OF COULTERS ON BAR 30" ROWS				
ITEM	PART NO.	QTY.	QTY.	QTY.	QTY.	DESCRIPTION
		11	13	15	17	
1	237	2	2	2	2	NUT HH 1/2 CENTER LOCK ZP
2	17063	2	2	2	2	PIN, MAIN WING
3	257	2	2	2	2	BOLT HH 1/2 X 3-1/2 GR5 ZP
4	131		4	4	4	BOLT HH 3/8 X 2-1/2 GR5 ZP NUT HH 3/8 CENTERLOCK ZP
5	237		4	4	4	BOLT HH 3/8 CENTERLOCK ZP
6	17814		2			WING EXTENSION
7	17079		4	4	4	PIN, FLIP WING PIVOT
8	17053	2	2	2	2	WING, MAIN
9	590217	4	4	4	4	BOLT, CARRIAGE 3/8 X 1 ZP
10	17897	2	2	2	2	BRACKET, LIGHT
11	250	4	4	4	4	WASHER, LOCK 3/8 ZP
12	213	4	4	4	4	NUT HH 3/8 ZP
13	590108	2	2	2	2	U-BOLT 7 X 7 X 5/8 ZP
14	15836	2	2	2	2	MOUNT, 3PT TAIL LIGHT
15	253	4	4	4	4	LOCKWASHER 5/8 ZP
16	216	4	4	4	4	NUT, HEX HEAD 5/8
17	239	2	2	2	2	NUT HH 1/2 CENTER LOCK ZP
18	155	2	2	2	2	BOLT HH 1/2 X 2-1/2 GR5 ZP
19	17026	2	2	2	2	PIN, CYLINDER MAIN WING
20	17834				2	EXTENSION, FLIP WING
21	474			2	2	BOLT HH 5/8 X 7-1/2 GR5 ZP
22	17142			2	2	WING LOCK CATCH
23	153				8	BOLT HH 1/2 X 2 GR5 ZP
24	215				8	NUT HH 1/2 ZP
25	216			2	2	NUT HH 5/8 ZP
26	17170			2	2	WING, FLIP
27	700			2	2	PIN, ROLL 1/4 X 1-1/2
28	590179			2	2	WASHER, MACHINERY 1 X 14 GA
29	17060			2	2	PIN LINK CYLINDER
30	17076			2	2	LINK, FLIP WING, INNER
31	17080			2	2	LINK, FLIP WING, OUTER
32	710005			2	2	CLIP, QUICK LOCK
33	8339			2	2	PIN. WING LOCK
34	17083			2	2	PIN. FLIP WING LINKAGE
35	17887			2	2	STAND, FLIP WING LOCK
36	476			2	2	BOLT HH 5/8 X 8-1/2 GR5 ZP
37	236	2	2	2	2	NUT HEX 5/16 CENTERLOCK ZP
38	240			2	2	NUT HH 5/8 CENTERLOCK ZP
39	261			2	2	WASHER FLAT 5/8 ZP
40	115	2	2	2	2	BOLT HEX HEAD 5/16 X 1 GR5 ZP
41	17143			2	2	FLIP WING LATCH
42	170			2	2	BOLT HH 5/8 X 2 GR5 ZP
43	10327	2	2	2	2	HOLDER, HOSE
44	1226	2	2	2	2	PIN, LOWER 3PT
45	17165	1	1	1	1	TOOLBAR 3PT CENTER SECTION
46	1225	1	1	1	1	PIN, UPPER 3PT
47	16372	4	4	4	4	TUBE, HORIZONTAL BASE
48	16375	4	4	4	4	TUBE, HEIGHT ADJUSTMENT
49	590017	2	2	2	2	PIN, HAI PIN COTTER
50	1056	8	8	8	8	PIN, JACK STAND
51	17808	2	2	2	2	PIN LOCK TRANSPORT
52	17162	2	2	2	2	BRACKET, HOSE RING HOLDER

813P Center Section

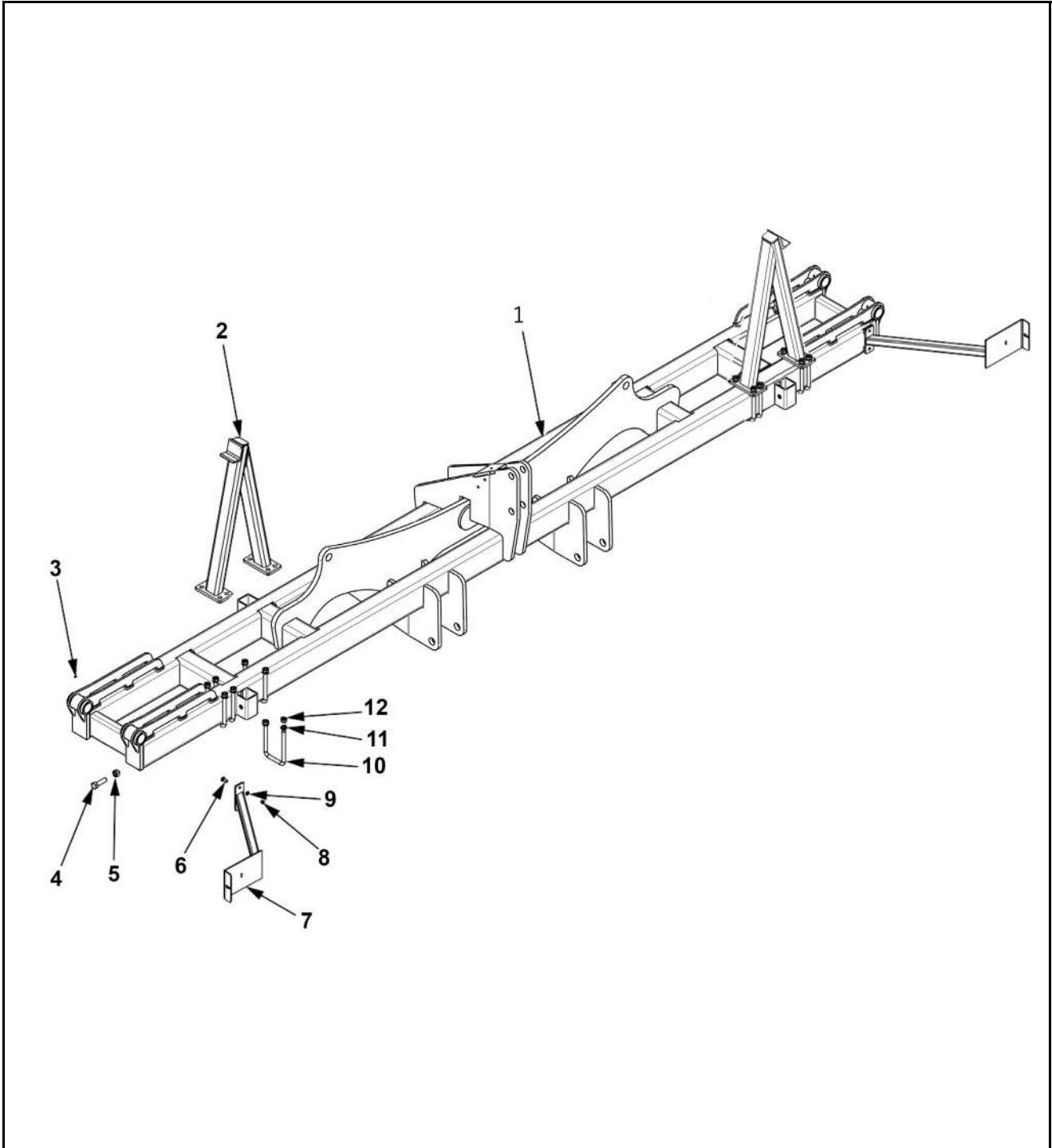



ILLUSTRATED PARTS LIST

813P Center Section Parts List

ITEM	PART NO.	QTY.	DESCRIPTION
1	19350	1	Center Section 60' Vertical Fold (813P)
2	16573	2	WingStand
3	759	4	Zerk 1/4-28
4	185	4	Bolt Hex Head 3/4-2-1/2 Grade 5 Zp
5	217	4	Nut Hex Head 3/4 Zp
6	590217	4	Bolt Carriage 3/8 X 1 Zp
7	17897	2	Light Mount Vertical Fold Toolbars
8	250	4	Washer Lock 3/8 Zp
9	213	4	Nut Hex Head 3/8 Zp
10	590053	8	U-Bolt 5/8 X 4 X 6 Square Bend
11	253	16	Washer Lock 5/8 Zp
12	216	16	Nut Hex Head 5/8 Zp

813P Inner and Outer Wing Section

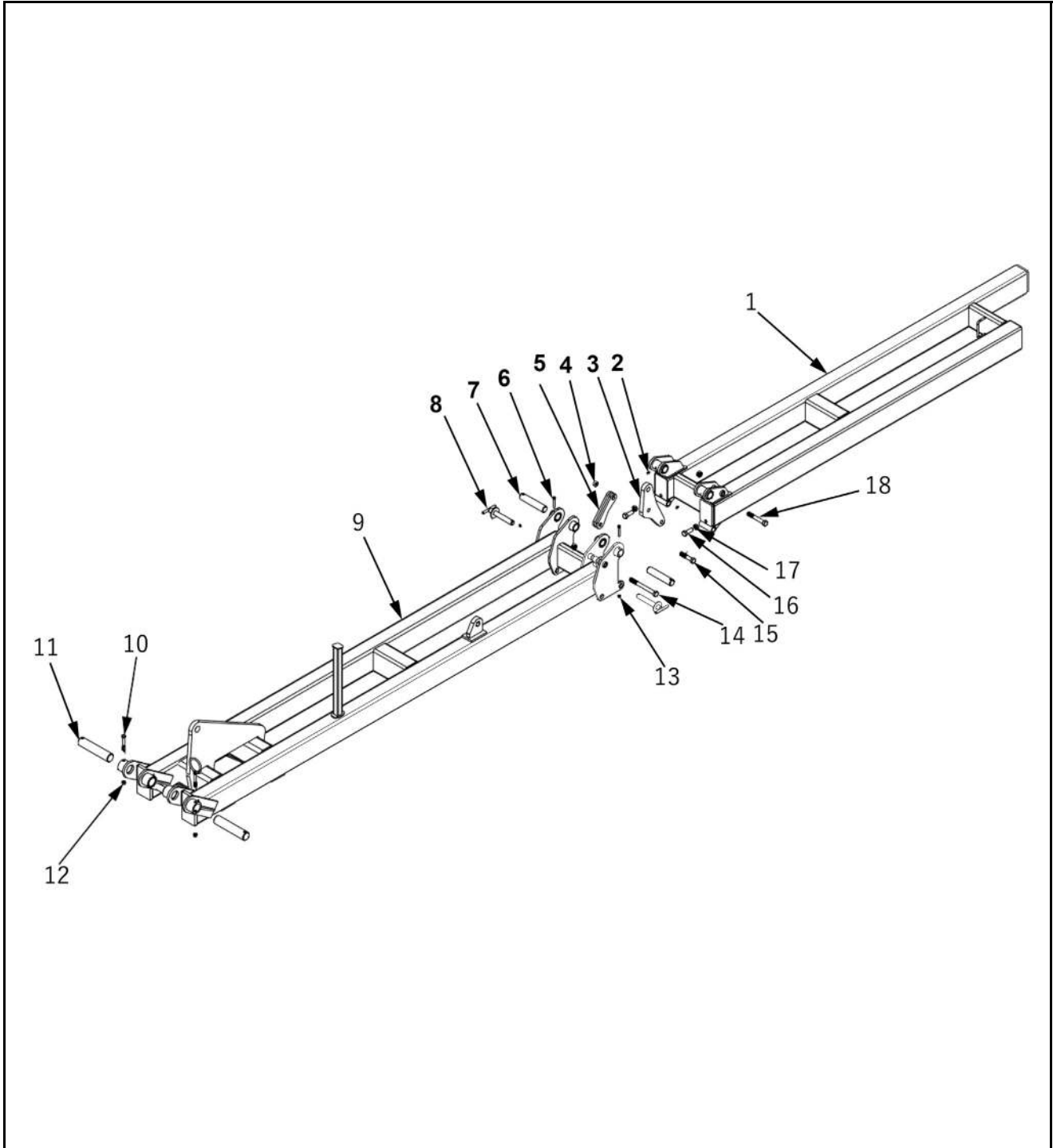



ILLUSTRATED PARTS LIST

813P Inner and Outer Wing Section Parts List

ITEM	PART NO.	QTY.	DESCRIPTION
1	5503L	1	Flip Wing 60' Double Bar LH
2	5503R	1	Flip Wing 60' Double Bar RH
2	7598	4	Zerk 1/4-28Zp
3	5539	2	Scissor Link 1" Boomerang
4	241	6	Nut Hex Head 3/4" Centerlock Zp
5	5543	2	Link Fork Folding
6	131	4	Bolt Hex Head 3/8 X 2-1/2 Grade 5 Zp
7	5617	4	Pin Hinge 1-1/2
8	5743	4	Tee Handle Lock Pin
9	13910L	1	Wing Main 60' Double Bar LH
9	13910R	1	Wing Main 60' Double Bar RH
10	157	4	Bolt Hex Head 1/2 X 3-1/2 Grade 5 Zp
11	2120	4	Pin Pivot Main Wing
12	238	4	Nut Hex Head 1/2" Centerlock Zp
13	237	4	Nut Hex Head 3/8" Centerlock Zp
14	396	2	Bolt Hex Head 3/4 X 7-1/2 Grade 8 Zp
15	386	2	Bolt Hex Head 3/4 X 3-1/2 Grade 8 Zp
16	184	2	Bolt Hex Head 3/4 X 2 Grade 5 Zp
17	225	4	Nut Jam 3/4 Zp
18	389	2	Bolt Hex Head 3/4 X 5 Grade 8 Zp

Gauge Wheel

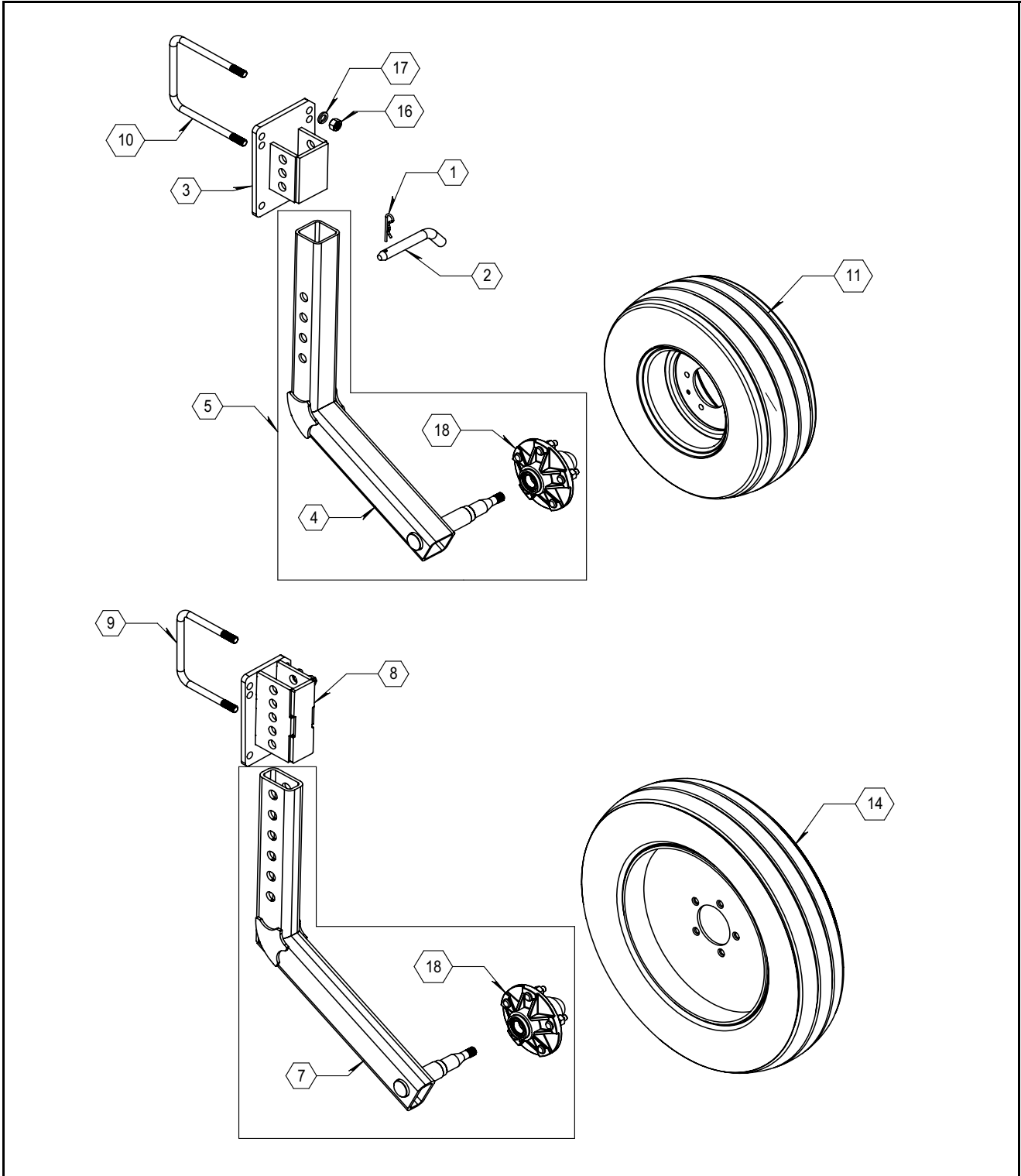



ILLUSTRATED PARTS LIST

Gauge Wheel Parts List

ITEM	PART NO.	QTY.	DESCRIPTION
1	285	AR	PIN, HITCH, 1/8 X 3-1/8" ZP
2	19061	AR	PIN, CROSS
3	19055L	AR	STANDARD GAUGE WHEEL MOUNT
NS	19055R	AR	STANDARD GAUGE WHEEL MOUNT
4	19060L	AR	STANDARD GAUGE WHEEL ARM
NS	19060R	AR	STANDARD GAUGE WHEEL ARM
5	19063L	AR	STANDARD ARM WITH HUB
NS	19063R	AR	STANDARD ARM WITH HUB
6	22041L	AR	NARROW ARM WITH HUB
NS	22041R	AR	NARROW ARM WITH HUB
7	22045L	AR	NARROW GAUGE WHEEL ARM
NS	22045R	AR	NARROW GAUGE WHEEL ARM
8	22050L	AR	NARROW GAUGE WHEEL MOUNT
NS	22050R	AR	NARROW GAUGE WHEEL MOUNT
9	590061	AR	U-BOLT 5/8 X 5 X 7"
10	590108	AR	U-BOLT 5/8 X 7 X 7"
11	700023	AR	WHEEL, 20.5 X 8 X 10, YELLOW
12	700030	AR	WHEEL, 20.5 X 8 X 10, SILVER
13	700133	AR	NARROW WHEEL, SILVER
14	700134	AR	NARROW WHEEL, YELLOW
15	730030	AR	NUT, LUG
16	596216M	AR	NUT, HEX 5/8 MAGNI
17	596253M	AR	LOCKWASHER 5/8 MAGNI
18	730003ASSY	AR	HUB ASSEMBLY

Q736 Hub Assembly, 5 Bolt

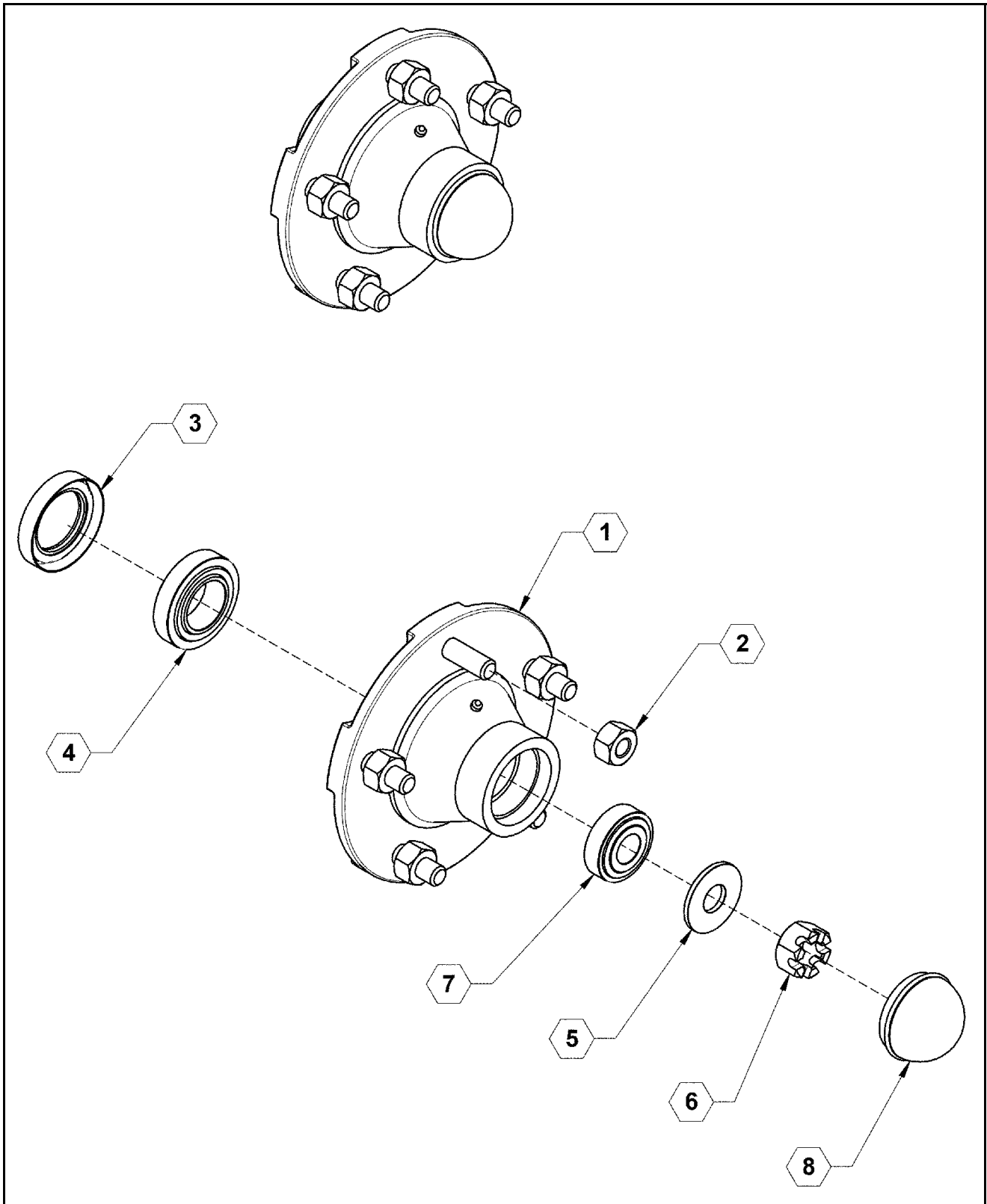



ILLUSTRATED PARTS LIST

Q736 Hub Assembly, 5 Bolt Parts List

ITEM	PART NO.	QTY.	DESCRIPTION
1	730003	1	Q736 HUB ASSEMBLY (ITEMS 1-7)
2	1724	5	WHEEL STUD BOLT, 913576
2	1725	5	WHEEL LUG NUT, 912919
3	1716	1	SEAL QDS 906296
4	1710	1	INNER CUP (LM67010)
4	1712	1	INNER CONE (LM67048)
5	730034	1	HUB WASHER
6	730035	1	CASTLE NUT N669
7	1711	1	OUTER CUP (LM11910)
7	1713	1	OUTER CONE (LM11949)
8	1714	1	HUB CAP QDS 909931

Mounting Clamp Kit for Auscherman Coulter Option

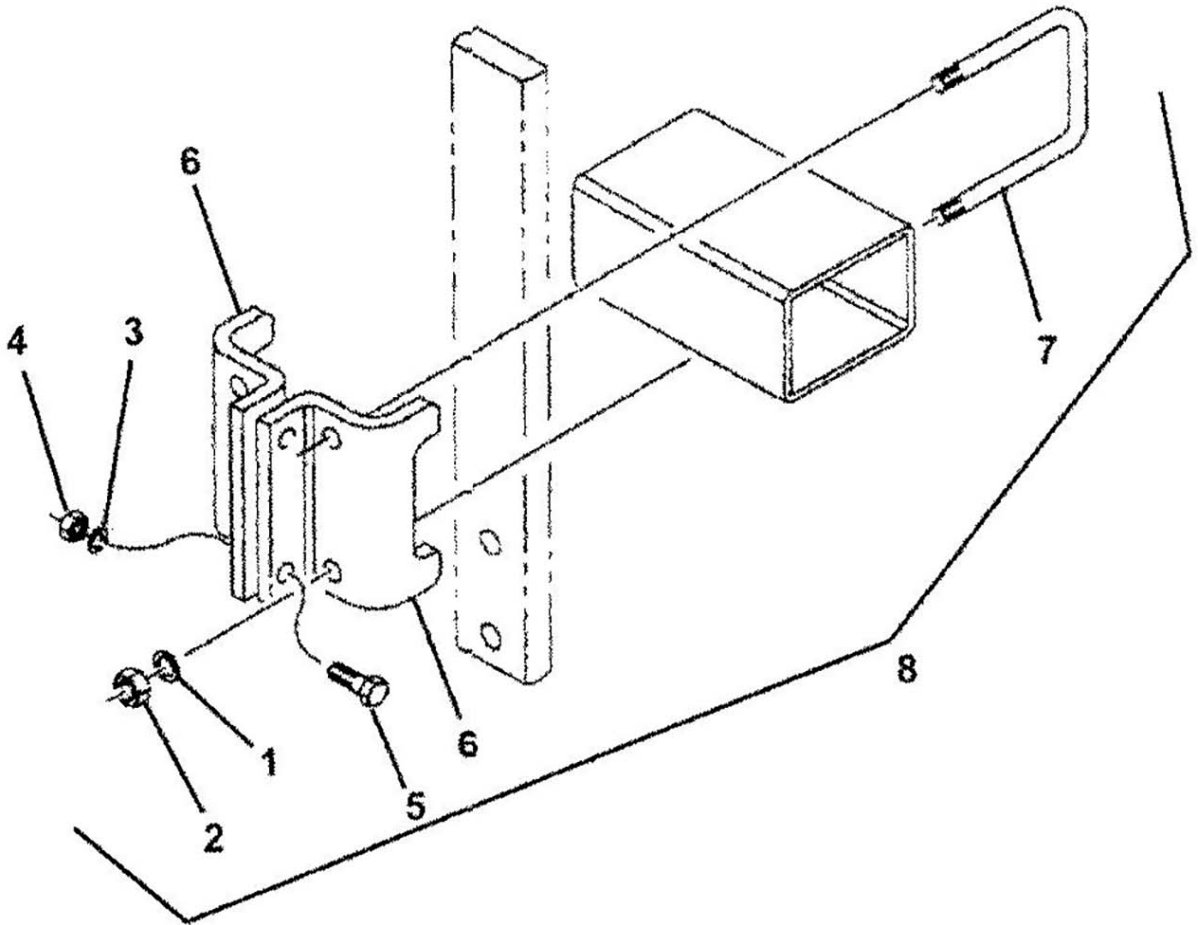



ILLUSTRATED PARTS LIST

Mounting Clamp Kit for Auscherman Coulter Option Parts List

ITEM	VENDOR PART NO.	FAST PART NO.	QTY.	DESCRIPTION
1	804-022C	253	4	LOCKWASHER 5/8" ZP
2	803-021C	216	4	NUT HEX 5/8 ZP
3	804-015C	252	2	LOCKWASHER 1/2" ZP
4	803-020C	215	2	NUT HEX 1/2" ZP
5	802-091C	153	2	BOLT HEX HEAD 1/2 X 1-1/2 GR5 ZP
6	204-188D		AR	6" SPLIT BAR CLAMP
6	204-189D		AR	7" SPLIT BAR CLAMP
7	806-116C		AR	U-BOLT 6 X 4 X 5/8, Use With 204-356k
7	806-083C		AR	U-Bolt 5/8-11 X 7 1/32 X 7 1/2, Use With 204-228k
7	806-084C		AR	U-Bolt 5/8-11 X 7 1/32 X 9 1/2, Use With 204-224k
7	806-131C		AR	U-Bolt 5/8-11 X 7 1/32 X 6, Use With 204-243k
8	204-356K	750024	1	6 X 4 BAR CLAMP KIT
8	204-224K	750046	1	7 x 7" Square Bar Clamp Kit
8	204-228K	750047	1	7 x 5" Square Bar Clamp Kit



ILLUSTRATED PARTS LIST

Auscherman Vantage II Coulter

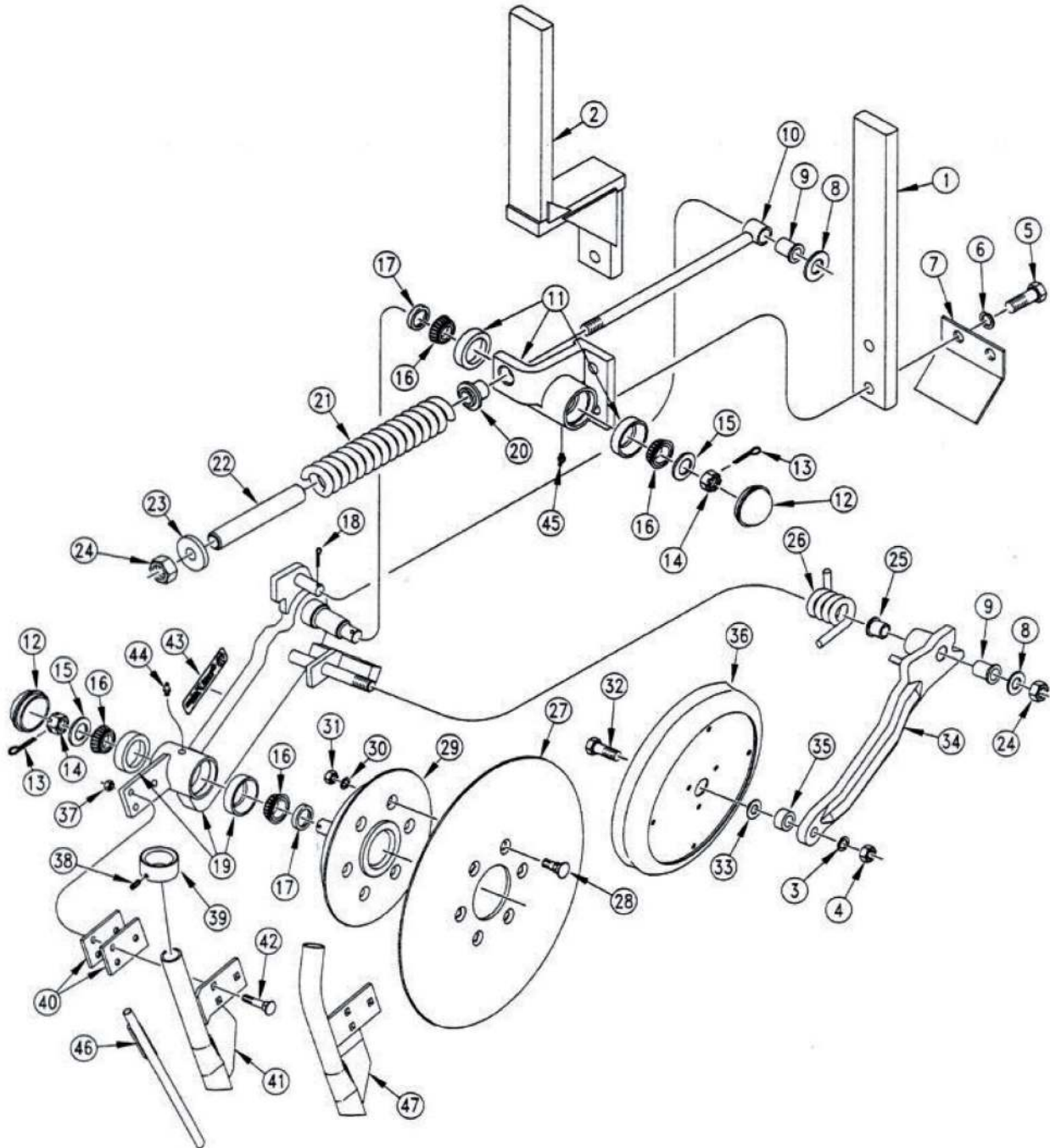



ILLUSTRATED PARTS LIST

Auscherman Vantage II Coultter Parts List

ITEM	VENDOR PART NO.	FAST PART NO.	QTY.	DESCRIPTION
1	807-124C	750026		21" Flat Bar Angled Coultter Shank
2	820-181C			Vantage II 5" Offset Flat Shank RH (Shown)
NS	820-182C			Vantage II 5" Offset Flat Shank LH
NS	804-022C			Washer Lock Spring 5/8
NS	803-021C			Nut Hex 5/8-11 Plt
5	802-064C			Hex Head Cap Screw 3/4-10 X 2 Grade 5
6	804-023C			Washer Lock Spring 3/4
7	204-154D			Front Shield
8	804-025C			Washer Flat 3/4 SAE
9	817-051C			Swing Arm Bushing
10	204-209H			Blade Spring Rod Weldment
11	204-233V			Coultter Pivot RH Sub-Assembly (Shown)
	204-235V			Coultter Pivot LH Sub-Assembly
12	200-001D			Hub Grease Cap
13	805-017C			Pin Cotter 3/16 X 1-3/4
14	803-029C			Nut Hex Slotted 7/8-14
15	804-055C			Washer Spindle - 7/8
	822-020C			Bearing Cup LM-67010 (Not Shown)
16	822-021C			Bearing Cone LM-67048
17	816-009C			Oil Seal Double Lip
18	805-063C			Pin Cotter 3/32 X 1 Long
19	204-234V			Blade Arm RH Sub-Assembly (Shown)
	204-236V			Blade Arm LH Sub-Assembly
20	817-029C			Bushing Coultter Casting
21	807-074C			Spring 2.25 OD X .5 Coil
22	204-107D			Spring Rod Sleeve 1-1/8 OD
23	812-031C			Casting Coultter Spring Washer
24	803-025C			Nut Hex 3/4-10 Plt Nylock
25	817-084C			Parallel Arm Pivot Bushing
26	807-089C			Torsion Spring 3/8 Wire RH (Shown)
	807-090C			Torsion Spring 3/8 Wire LH
27	820-093C			Single Bevel 18 Coultter Blade
28	802-354C			Plow Bolt 1/2-13 X 1-1/2 Grade 5
29	204-145D			Coultter Hub
30	804-015C			Washer Lock Spring 1/2
31	803-020C			Nut Hex 1/2-13
32	802-281C			Hex Head Cap Screw 5/8-11 X 2-3/4 Grade 5
33	804-019C			Washer Flat 5/8 USS
34	201-141D			Wiper Wheel Arm RH (Shown)
	204-142D			Wiper Wheel Arm LH
35	204-153D			Wiper Wheel Spacer
36	198-057S			2 x 13 Depth Wheel Assembly
	822-095C			Press Wheel Bearing Only
	814-083C			Press Wheel Tire Only
37	803-013C			Nut Lock 3/8-16 Plt
38	801-015C			Screw Set Socket Head 1/4-20 (1/2)
39	204-268D			Dry Fertilizer Tube Collar
40	816-134C			Rubber Pad
41	820-124C			Dry Fertilizer Tube RH
	820-125C			Dry Fertilizer Tube LH
42	802-406C			RHSNB 3/8-16 (1-3/4 SS)
43	838-482C			Decal Gp Planting Components
44	800-001C			Grease Zerk Straight 1/4-28
45	800-073C			Grease Zerk 1/4-28 X 90°
46	890-580C			Vantage II Liquid Insert
47	204-412H	750025		Vantage II RH Dry Drop Tube Weldment (shown)
	204-413H			Vantage II LH Dry Drop Tube Weldment
	204-218L	750022		Coultter Vantage II RH (Incl 8-45,47)
	204-219L	750023		Coultter Vantage II LH (Incl 8-45,47 LH)



ILLUSTRATED PARTS LIST

Clymer Coultter Assembly

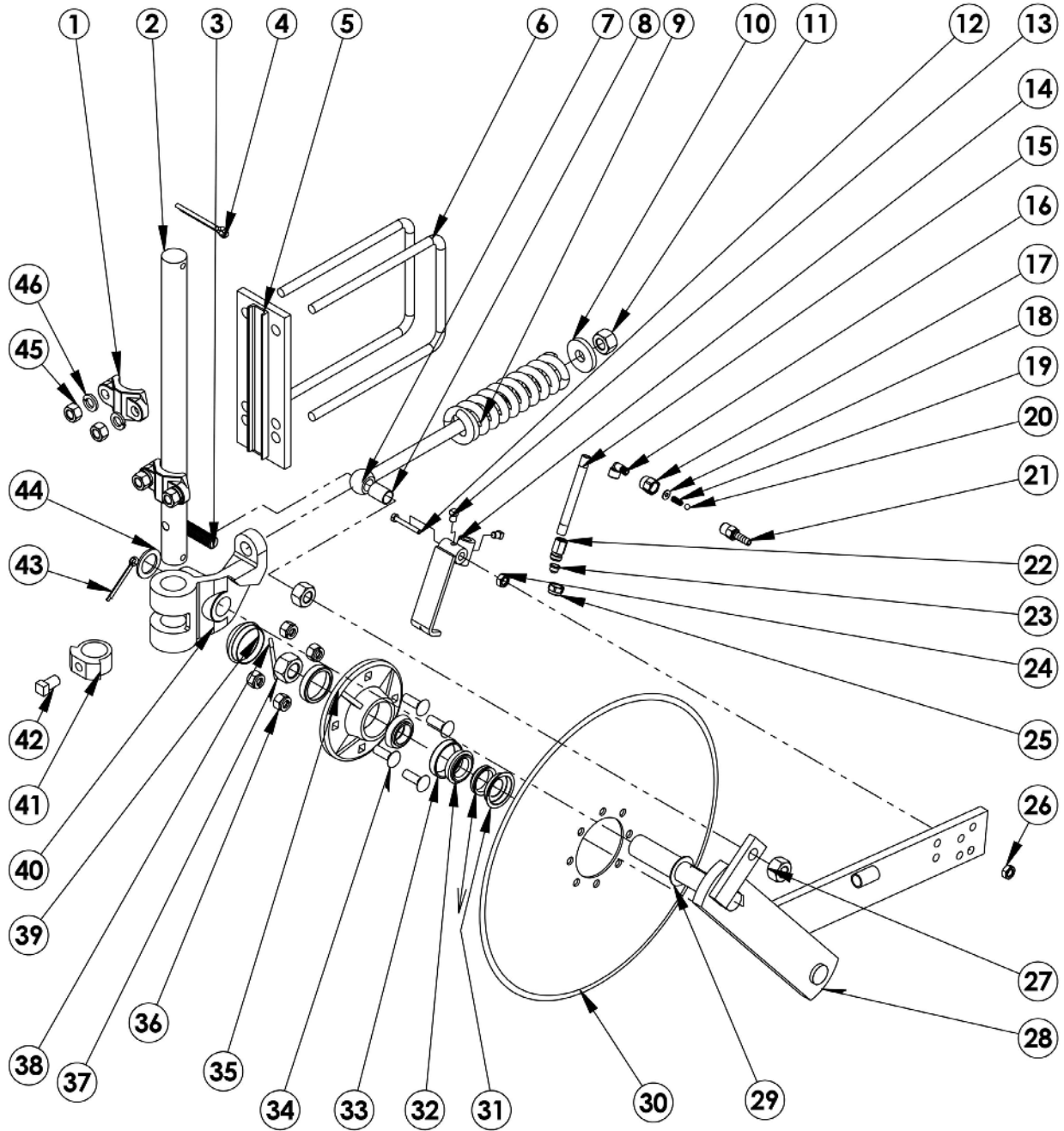



ILLUSTRATED PARTS LIST

Clymer Coulter Assembly Parts List

ITEM	VENDOR PART NO.	FAST PART NO.	QTY.	DESCRIPTION
1	N369	590005	2	Casting Clamp
2	N343	750012	1	1-1/2" Straight Coulter Shank
NS	N345	750055	AR	1-1/2" Offset Coulter Shank
NS		750054	1	1-1/2" Offset Coulter Shank Special
NS		750053	1	1-1/2" Offset Coulter Shank Special
3		186	1	Bolt Hex Head 3/4 X 3 Grade 5 Zp
4	FPC510		2	Cotter Pin 5/16" X 3
5	N367-1		1	Clamp Plate
6	FBU6B0		2	U-Bolt 7 X 8-1/2 X 5/8 E-Coat
7	N347-7		1	Bushing Nylon For Spring Rod
8	N347-5		1	Spring Rod
9	S233		1	Spring Coulter
10	N347-3		1	Spring Bushing Casting
11		233	1	Nut Hex Head 3/4 Nylock Zp
12	FBH0816-SS	750010	1	Bolt Hex Head 1/2 X 4 Grade 5 SS
13	FBS0602	750018	2	Set Screw 3/8 X 1/2"
14	COI100-7	750016	1	Rock Guard
15	TJ-4676-22-1/4	530199	1	Nipple, Pipe 1/4 X 5 SS
16	TJ-CP4916-250	530246	1	Elbow, Street 1/4" NPT SS
		530188	1	Hose Shank Check Valve Assembly Items 17-21
17	TJ-4676-22-1/4		1	Adapter 11/16" X 1/4" NPT
18	TJ-CP4916-250		1	Orifice Plate 302 SS
19	TJ-CP3655-5-SS		1	Spring 5# 302 SS
20	TJ-CP7671-5/16/SS		1	Ball 302 SS
21	TJ-39189-8400-406-SS		1	Hose Shank 11/16 X 1/4" NPT 303 SS
22	TJ-CP1321-SS	520014	1	Teejet Body SS
23	TP-00xx-SS		1	Tip SS Teejet (Specify Tip Size)
24	FNJ08-SS	750009	1	Hut Hex Head Jam 1/2" SS
25	TJ-CP1325SS	750015	1	Nozzle Cap SS
26	FNJL08-SS	750011	1	Nut Hex Head Nylock 1/2" SS
27	FNL12-NF		1	Nut Hex Head 3/4" Nf Zp
28	N347-47		1	Swing Arm W Hub
29	N347-6		1	Bushing Coulter Flanged
30	N342	750014	1	Coulter Ripple 20"
31	W40-2		1	Seal Coulter 2 Piece
32	W32		1	Bearing
33	W38		2	Cup
34	FBC0806		2	Bolt Carriage 1/2" X 1-1/2" Zp
35	W23Y		4	Hub Assembly Complete (Items 31-33,35,37-39)
	W23		1	Hub Only
36	FNH08		1	Nut Hex Head 1/2" Zp
37	W60		4	Nut Spindle 5/8"
38	FPC497		1	Pin Cotter 1/8" X 1-1/4"
39	W50		1	Cap Hub
40	N347-1		1	Coulter Hinge Casting
41	N347-2	750008	1	Locking Collar 30°
NS	N347-2/45		OPT.	Locking Collar 45°
42	FBS1004		1	Setscrew 5/8" X 1"
43	FPC505		1	Pin Cotter 1/8" X 1-1/4"
44	FWM18		1	Bushing 1/8" Thick
45		216	4	Nut Hex Head 5/8" Zp
46		253	4	Washer Lock 5/8"



ILLUSTRATED PARTS LIST

Knife Assembly

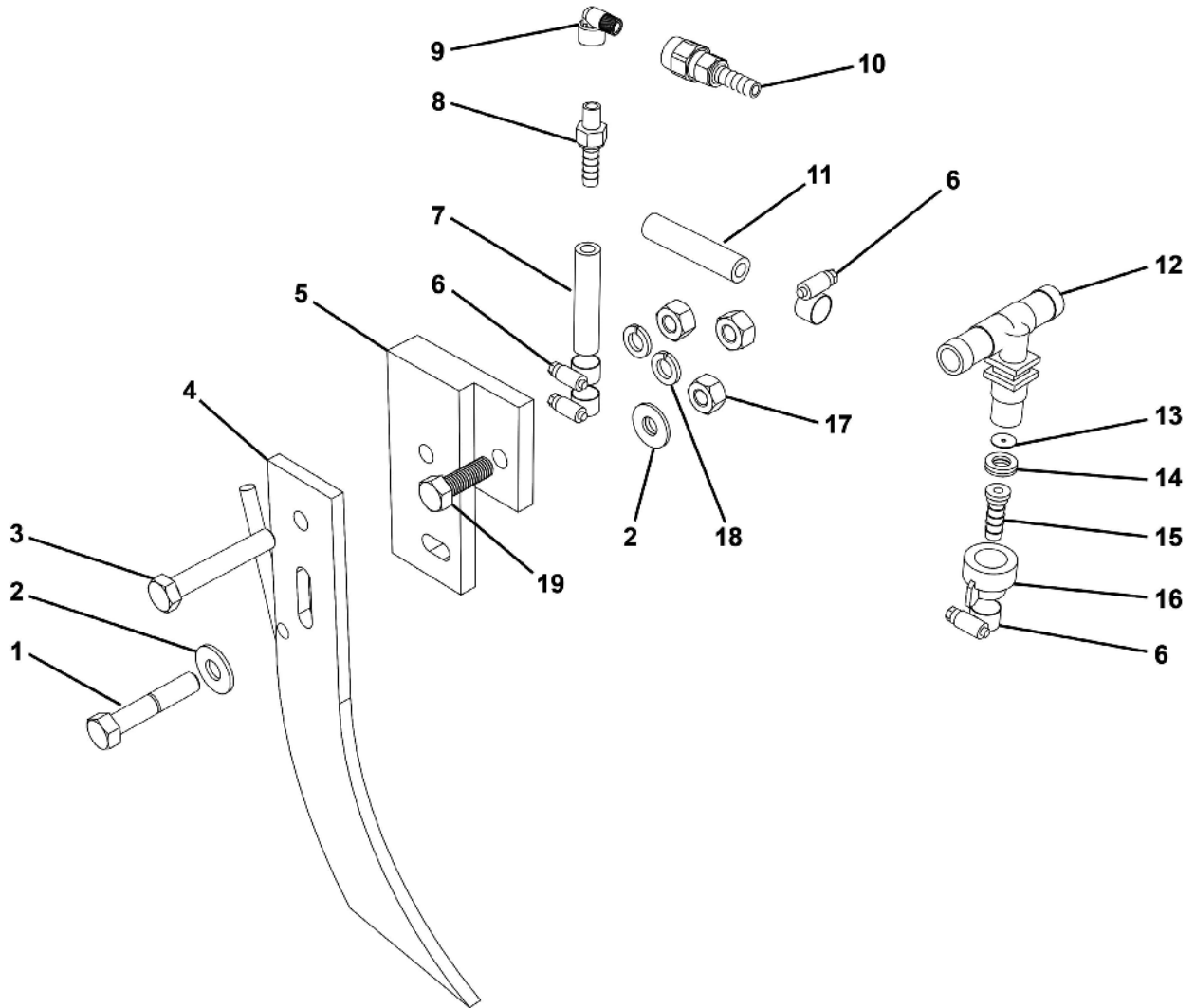



ILLUSTRATED PARTS LIST

Knife Assembly Parts List

ITEM	VENDOR PART NO.	FAST PART NO.	QTY.	DESCRIPTION
1		FBH0813	1	Bolt Hex Head 1/2 X 3-1/4 Zp Grade 5
2		260	2	Washer Flat 1/2" Zp
3		155	1	Bolt Hex Head 1/2 X 2-1/2 Zp Grade 5
4	WI-CO501000	750003	1	Wiese CO50100 Knife
5	CLN3934	750019	1	Mounting Bracket And Shim Kit
6	BR-64006H	540011	4	Clamp Hose 5/16"
7	BS-3/8BH200	510020	1	Hose EDPM 3/4" X 4'
8	VI-316A1438	530247	1	Hose Barb 1/4" MPT X 3/8" Hose
9	VI-304SE14	530246	1	Elbow Street 1/4" MPT
10	39188-8400-406-SS	530188	1	Valve Check 1/4" MPT X 3/8" Hose
11	BS-3/8BH200	510020	1	Hose EDPM 3/4" X 54'
12	18720-112-785-NYB	520004	AR	Tee 3/4" Hose Barb
NS	18719-111-785-NYB	520003	AR	L 3/4" Hose Barb
13	CP4916-XX	CP4916-XX	1	Orifice Disc 4916-XX See Rate Chart
14	CP18999EPR	590029	1	Gasket Orifice Disc
15	8400-406-NYB	590077	1	Hose Shank 3/8"
16	CP25607-1-NY	590076	1	Cap Nozzle Black
17		215	3	Nut Hex Head 1/2" Zp
18		252	3	Washer Lock 1/2" Zp
19		603	1	Bolt Hex Head 1/2 X 1-3/4" Zp Grade 5

AP Coultter Row Unit Base Assembly

NOTE:

- 7X7 TOOLBAR SHOWN FOR REFERENCE. 7X5 & 6X4 NOT SHOWN
- TORQUE REQUIREMENTS:
U-BOLT: 270 N-m (200 FT-LBS)
CROSS BOLTS: 285 N-m (210 FT-LBS)

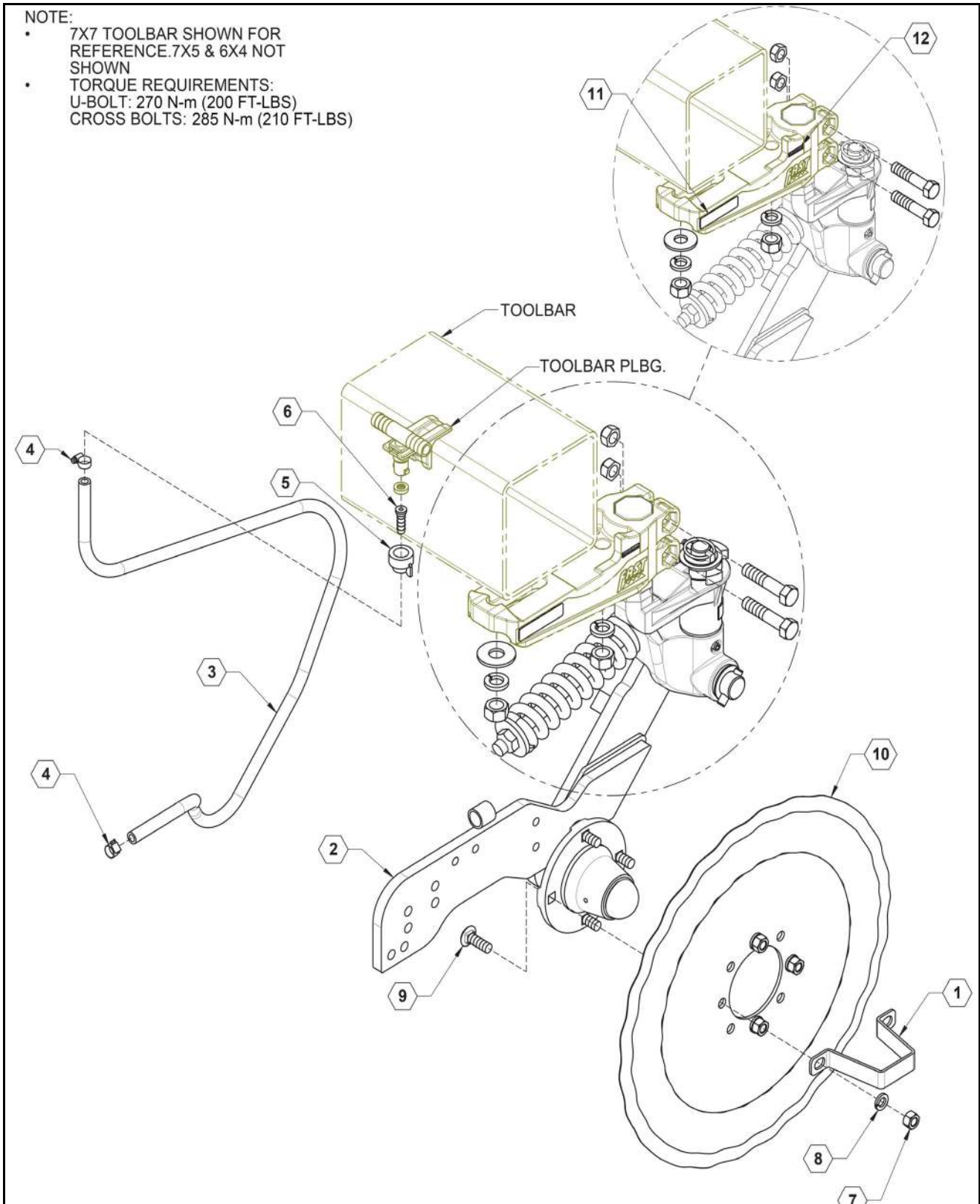



ILLUSTRATED PARTS LIST

AP Coulter Row Unit Base Assembly Parts List

ITEM	PART NO.	QTY.	DESCRIPTION
1	17214	1	HUB RETAINER BRACKET
2	17300	1	ASSY, AP COULTER ROW UNIT
3	510020	AR	HOSE, 3/8", EPDM
4	540032	2	CLAMP, HOSE SS 5/16" #5
5	590076	1	CAP
6	590077	1	CONNECTOR, HOSE BARB
7	596215M	4	NUT, HEX 1/2 NC GR5 MAGNI
8	596251M	4	WASHER, LOCK, 1/2 MAGNI
9	596620M	4	BOLT, CARR, 1/2X 1-1/2 GR5 MAGNI
10	750014	1	COULTER BLADE, 20" RIPPLED
11	800198	1	DECAL, UPPER MOUNT PATENT
12	800209	1	DECAL, D FAST GLOBAL SOLUTIONS

AP Coultter Row Unit Cast Coultter Assembly

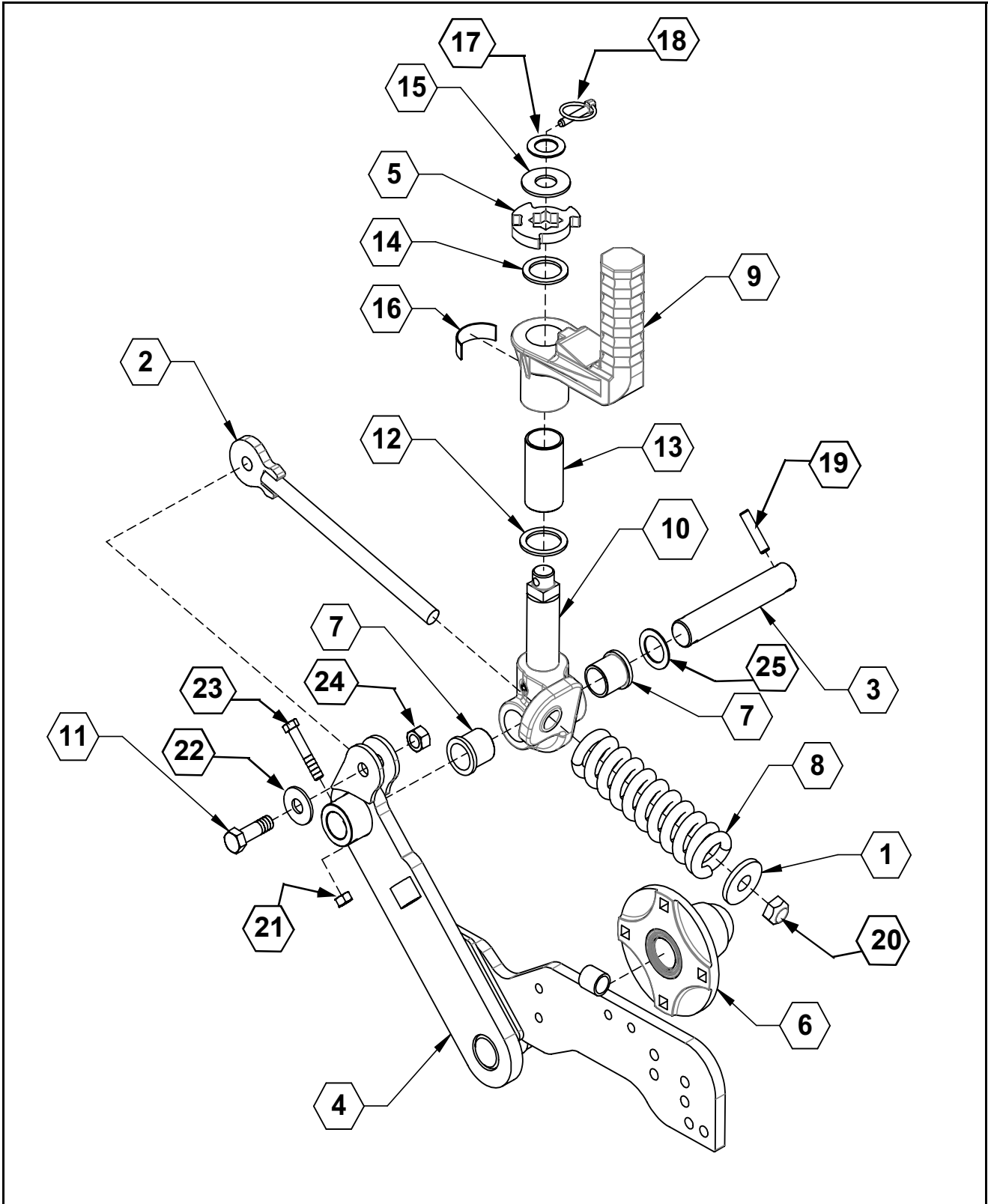



ILLUSTRATED PARTS LIST

AP Coulter Row Unit Cast Coulter Parts List

ITEM	PART NO.	QTY.	DESCRIPTION
1	17208	1	PLATE, SPRING END
2	17276	1	SPRING LEVER WELDMENT
3	17291	1	PIVOT SHAFT
4	17293	1	COULTER ARM WELDMENT
5	21088	1	PLATE, COULTER ROTATION
6	26891	1	N669 COMPLETE HUB W/ SQ HOLE W/TRIPLE SEAL
7	530328	2	IGUS FLANGED BUSHING
8	590123	1	COULTER SPRING
9	590232	1	MID CASTING
10	590233	1	LOWER CASTING
11	590260	1	BOLT, HH 5/8 X 2" SPECIAL GR5 MAGNI
12	750081	1	COULTER WASHER
13	750082	1	COULTER PIVOT BUSHING
14	750085	1	LOWER DUST CAP WASHER
15	750086	1	UPPER DUST CAP WASHER
16	800197	1	SHANK PATENT DECAL
17	596179M	1	BUSHING, MACHINED 1" X 14GA MAGNI
18	590819M	1	LYNCH PIN, 5/16 X 1-3/4 MAGNI
19	596740M	1	ROLL PIN, 7/16 X 2 MAGNI
20	596626M	1	NUT, TOPOCK 3/4-10 MAGNI
21	596238M	1	NUT, CENTERLOCK 7/16-14 MAGNI
22	596261M	1	WASHER, FLAT 5/8 MAGNI
23	596143M	1	BOLT, HH 7/16X2-1/2 GR5 MAGNI
24	596240M	1	NUT, CENTERLOCK, 5/8-11 MAGNI
25	596744M	1	BUSHING, MACHINED, 1-1/4 X 14 GA MAGNI

N669 Complete Hub W/ Square Hole w/ Triple Seal Assembly

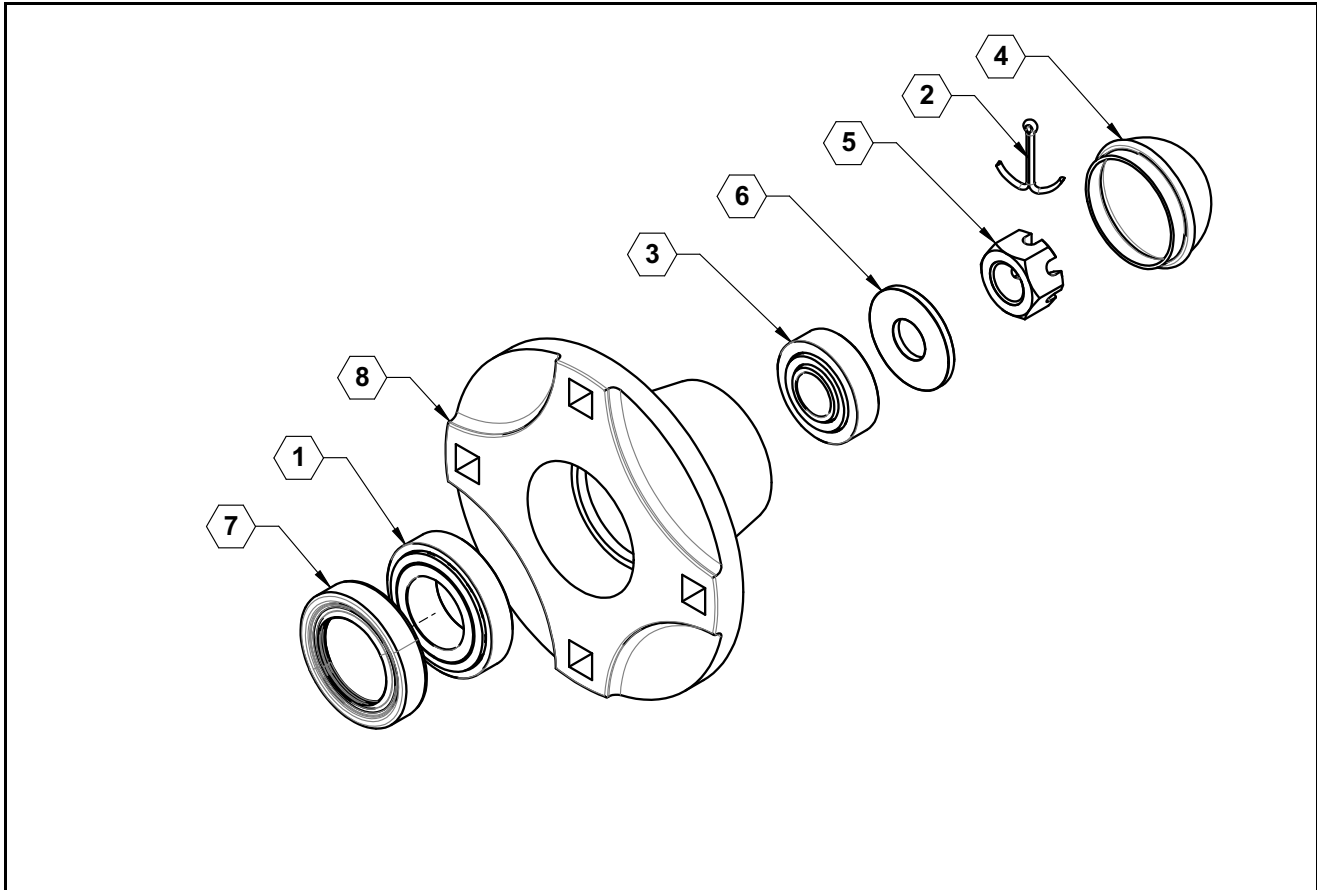

N669 Complete Hub w/ Square Hole w/ Triple Seal Parts List

ITEM	PART NO.	QTY.	DESCRIPTION
0	26891	1	N669 COMPLETE HUB, WITH SQUARE HOLE, WITH TRIPLE SEAL
1	730032	1	BEARING, LARGE LM67048, N669 HUB
2	730033	1	COTTER PIN, N669, 4-BOLT
3	730036	1	BEARING, SMALL LM11949, N669 HUB
4	730044	1	HUB CAP, (699/736) HUB
5	730088	1	CASTLE NUT 4-BOLT, 5/8-18
6	730096	1	WASHER, N669 4-BOLT
7	730102	1	SEAL, TRIPLE LIP ID
8	730104	1	HUB, WITH CUPS, 4 BOLT, N669



FAST GLOBAL
SOLUTIONS

AP Coulter Upper Casting Mounts

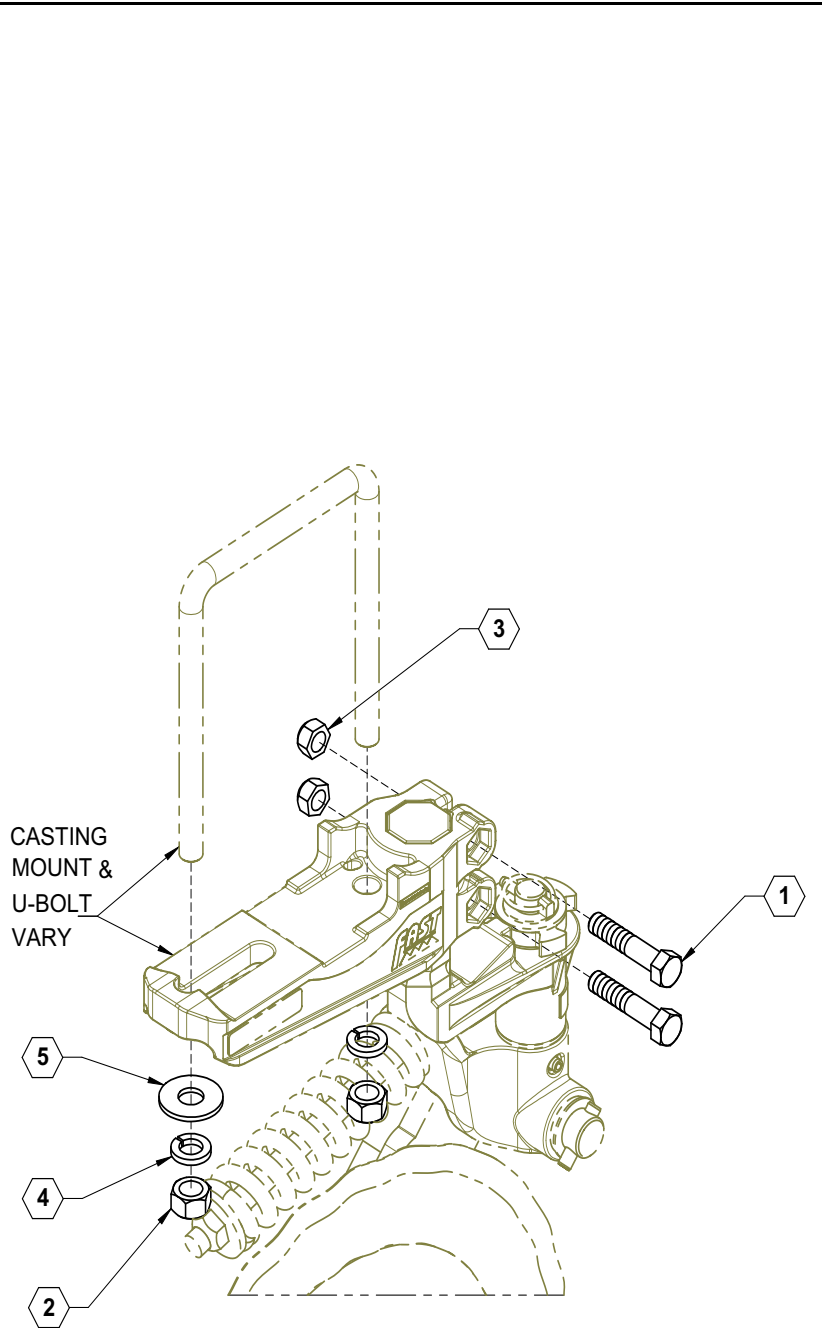
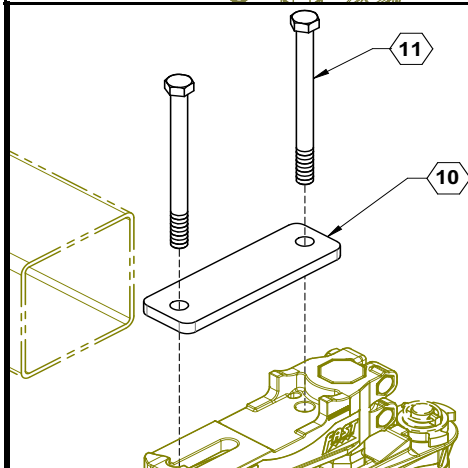
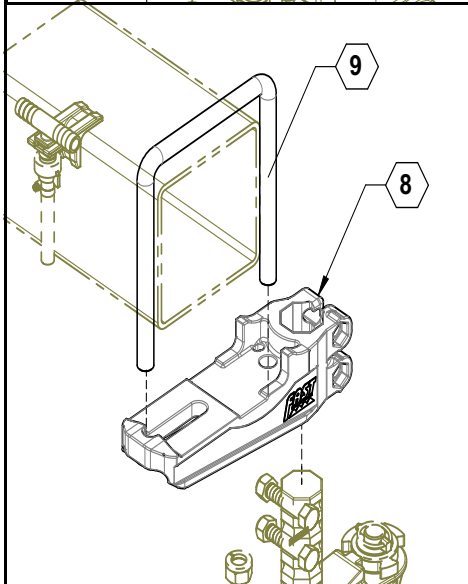
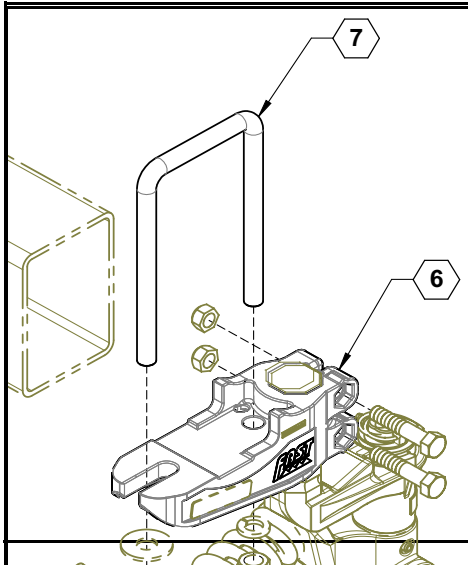

TORQUE REQUIREMENTS:
U-BOLT: 270 N-m (200 FT-LBS)
CROSS BOLTS: 285 N-m (210 FT-LBS)



ILLUSTRATED PARTS LIST

AP Coulter Upper Casting Mounts Parts List

ITEM	PART NO.	QTY.	DESCRIPTION
1	596779M	2	BOLT, G8 HEX 5/8 X 3 MAGNI
2	596217M	2	NUT, HEX 3/4-10 MAGNI
3	596243M	2	NUT, G8 TOPLOCK 5/8-11 MAGNI
4	596254M	2	LOCKWASHER 3/4 MAGNI
5	596259M	1	WASHER, FLAT 3/4 MAGNI
6	590310	1	MOUNT CASTING AP COULTER
7	596773M	1	U-BOLT, 7 X 5 MAGNI
	596772M	1	U-BOLT, 6 X 4 MAGNI
8	590231	1	MOUNT CASTING, 7X7 TB
9	596774M	1	U-BOLT, 7 X 7 MAGNI
10	17284	1	PLATE, TOP
11	596197M	2	BOLT, 3/4-10 X 9-1/2 MAGNI



ILLUSTRATED PARTS LIST

Injector and Knife Options

FAST AP Coulter Injection Option Assembly

No closing wheel

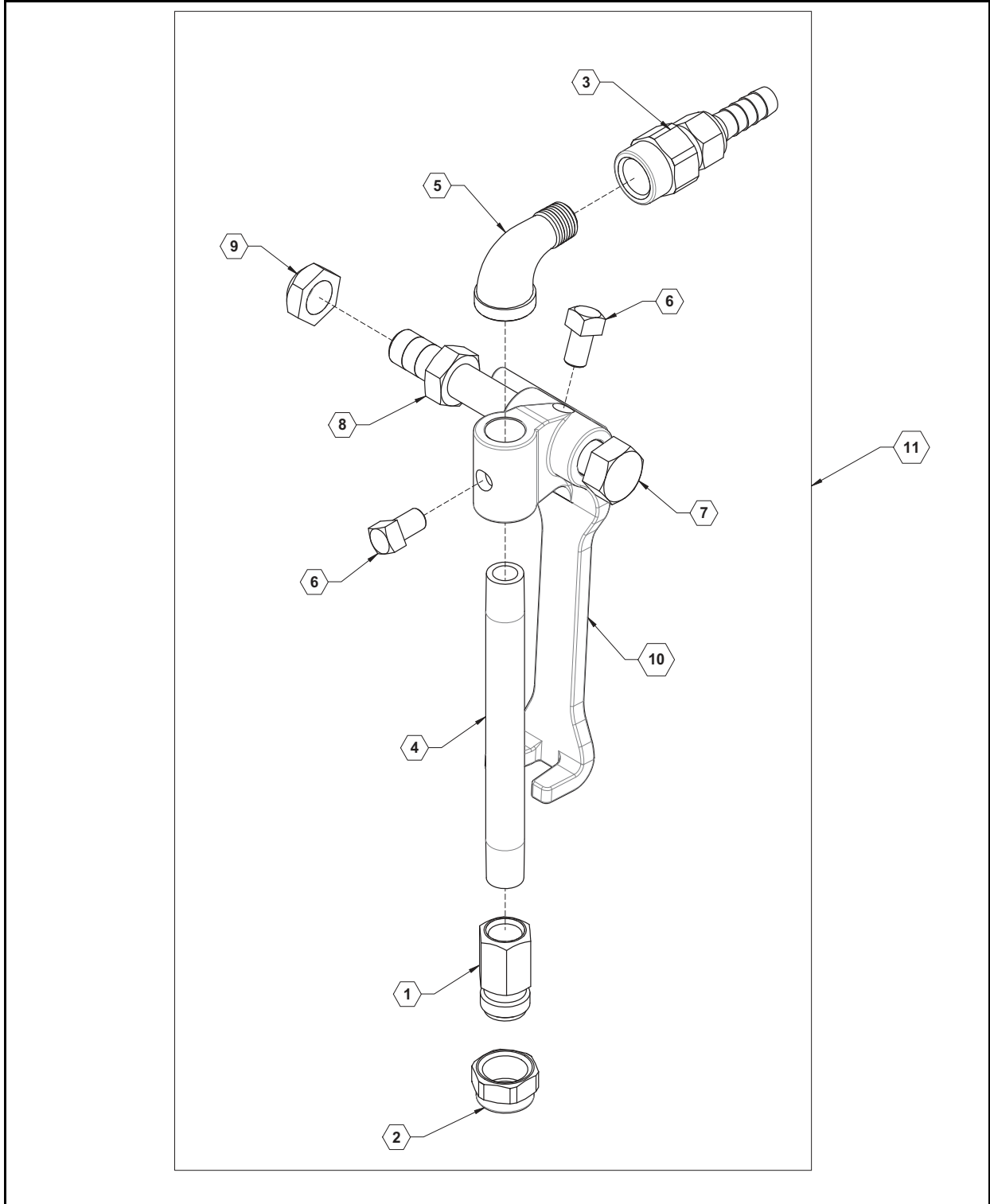



ILLUSTRATED PARTS LIST

FAST AP Coulter Injection Option Parts List

ITEM	PART NO.	QTY.	DESCRIPTION
1	520014	1	NOZZLE BODY, 1/4" SS
2	520015	1	NOZZLE CAP, SS
3	530188	1	CHECK VALVE ASSEMBLY
4	530199	1	PIPE NIPPLE, 1/4" SS
5	530246	1	ELBOW, 90° STREET 1/4 NPT SS
6	596100M	2	SET SCREW, 3/8-16X 1/2 MAGNI
7	596158M	1	BOLT, HH 1/2 X 4 GR5 MAGNI
8	596223M	1	NUT, HEX JAM 1/2-13 MAGNI
9	596618M	1	NUT, TOPLOCK THIN 1/2-13 MAGNI
10	750016	1	ROCK GUARD, WELDED
10	750084	1	ROCK GUARD, CAST
11	90SAINJ	AR	COMPLETE INJECTOR ASSEMBLY
NS	520049	AR	#8 STREAM JET TIP
NS	520056	AR	#10 STREAM JET TIP
NS	520034	AR	#15 STREAM JET TIP
NS	520035	AR	#20 STREAM JET TIP
NS	520096	AR	#30 STREAM JET TIP
NS	520097	AR	#40 STREAM JET TIP

DeFender® for Injection Assembly

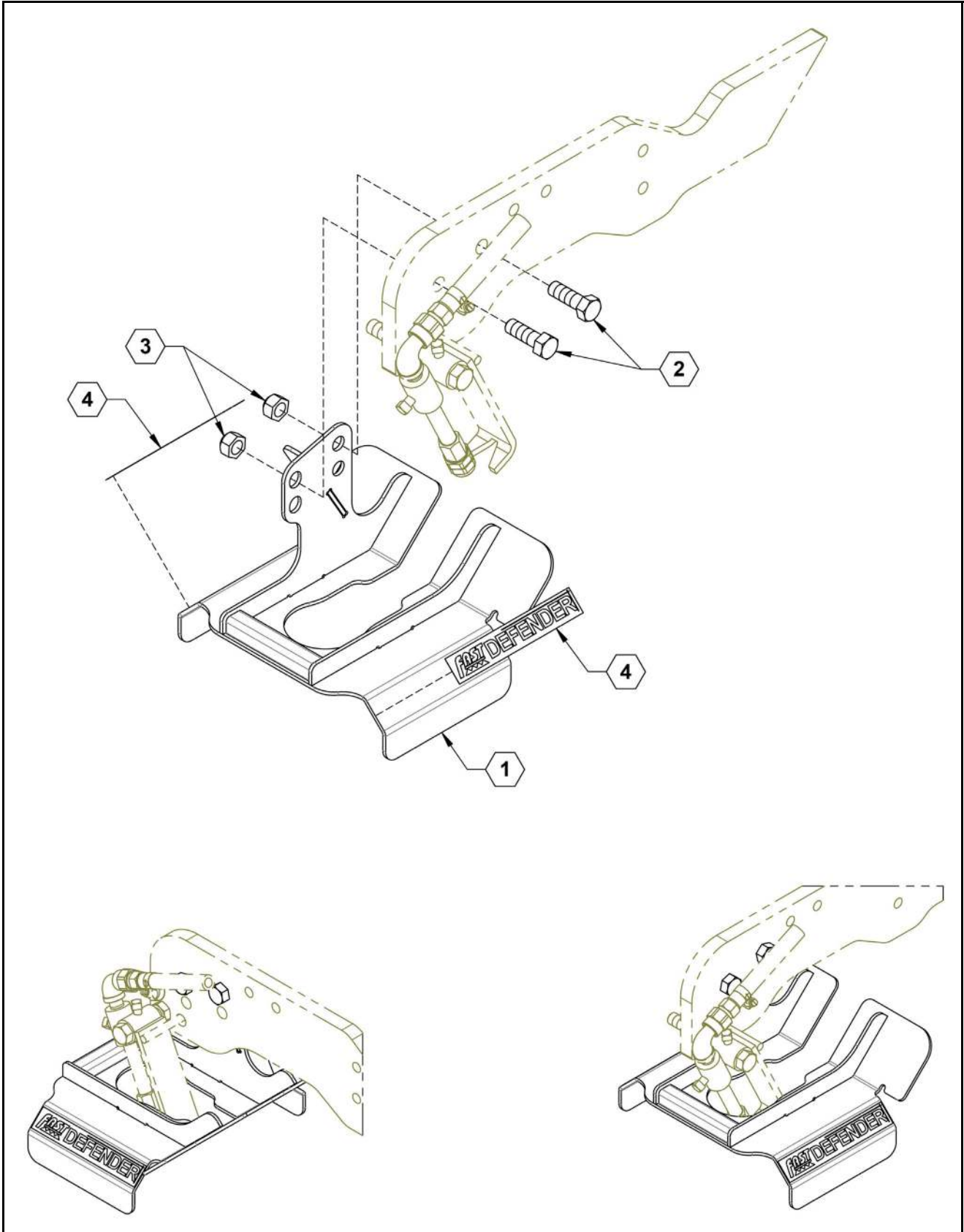



ILLUSTRATED PARTS LIST

DeFender® for Injection Parts List

ITEM	PART NO.	QTY.	DESCRIPTION
1	21805	1	COULTER DEFENDER®
2	596153M	2	BOLT, HH 1/2-13X1-1/2 GR5 MAGNI
3	596619M	2	NUT, TOPLOCK 1/2-13 MAGNI
4	800273	2	DECAL, FAST DEFENDER®

AP Coulter Knife Option Assembly

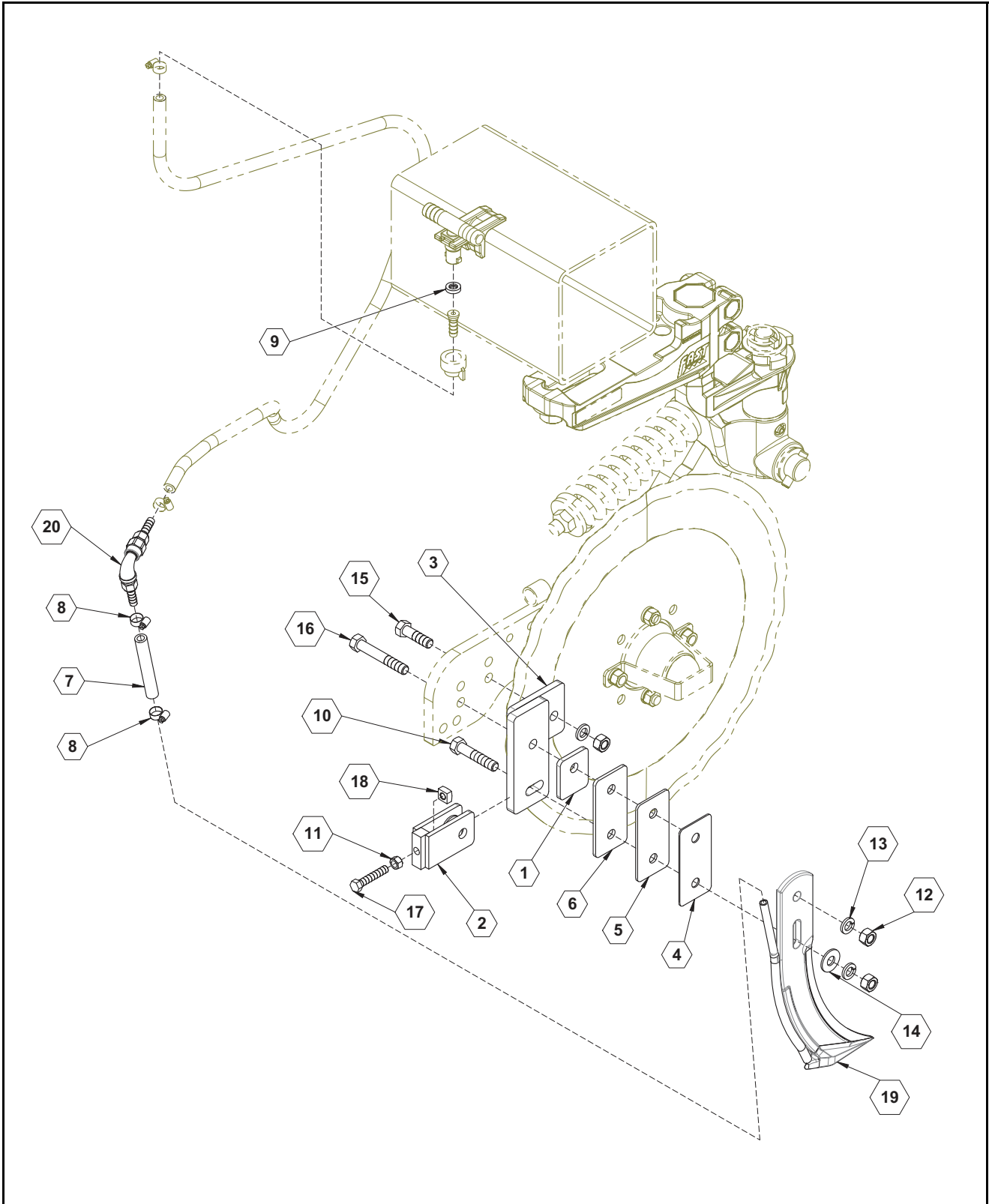



ILLUSTRATED PARTS LIST

AP Coulter Knife Option Parts List

ITEM	PART NO.	QTY.	DESCRIPTION
1	17909	1	PLATE, SHIM SPACER
2	17910	1	KNIFE ADJUSTER BRACKET
3	17915	1	KNIFE MOUNT
4	17920	1	KNIFE SHIM, 14 GA
5	17921	1	KNIFE SHIM, 10 GA
6	17922	1	KNIFE SHIM, 7 GA
7	510020	1	HOSE, 3/8", EPDM
8	540032	2	CLAMP, HOSE SS 5/16" #5
9	590029	1	SEAL, EPDM
10	596155M	1	BOLT, HH 1/2 X 2.5" GR5 MAGNI
11	596213M	1	NUT, HEX 3/8-16 MAGNI
12	296215M	3	NUT, HEX 1/2" MAGNI
13	596251M	3	WASHER, LOCK, 1/2 MAGNI
14	596260M	1	WASHER, FLAT 1/2 MAGNI
15	596639M	1	BOLT, HH 1/2 X 1.75" GR5 MAGNI
16	596640M	1	BOLT, HH 1/2 X 3.25" GR5 MAGNI
17	596660M	1	BOLT, HH 3/8 X 2" FT GR5 MAGNI
18	596762M	1	NUT, SQUARE 3/8" MAGNI
19	750003	1	KNIFE, EXTRA THIN W/ 3/8"PIPE
20	90SACLYKNFCHCKVLV	1	KNIFE CHECK VALVE ASSEMBLY
NS	CP491663	AR	#63 ORIFICE DISK
NS	CP491665	AR	#65 ORIFICE DISK
NS	CP491672	AR	#72 ORIFICE DISK
NS	590334	AR	#75 ORIFICE DISK
NS	CP491677	AR	#77 ORIFICE DISK
NS	CP491678	AR	#78 ORIFICE DISK
NS	CP491680	AR	#80 ORIFICE DISK
NS	CP491689	AR	#89 ORIFICE DISK
NS	CP491691	AR	#91 ORIFICE DISK
NS	CP491693	AR	#93 ORIFICE DISK
NS	CP4916103	AR	#103 ORIFICE DISK
NS	590031	AR	#107 ORIFICE DISK
NS	CP4916115	AR	#115 ORIFICE DISK
NS	CP4916125	AR	#125 ORIFICE DISK
NS	590335	AR	#132 ORIFICE DISK
NS	CP4916144	AR	#144 ORIFICE DISK
NS	CP4916151	AR	#151 ORIFICE DISK
NS	CP4916177	AR	#177 ORIFICE DISK

Coulter Decal Assembly

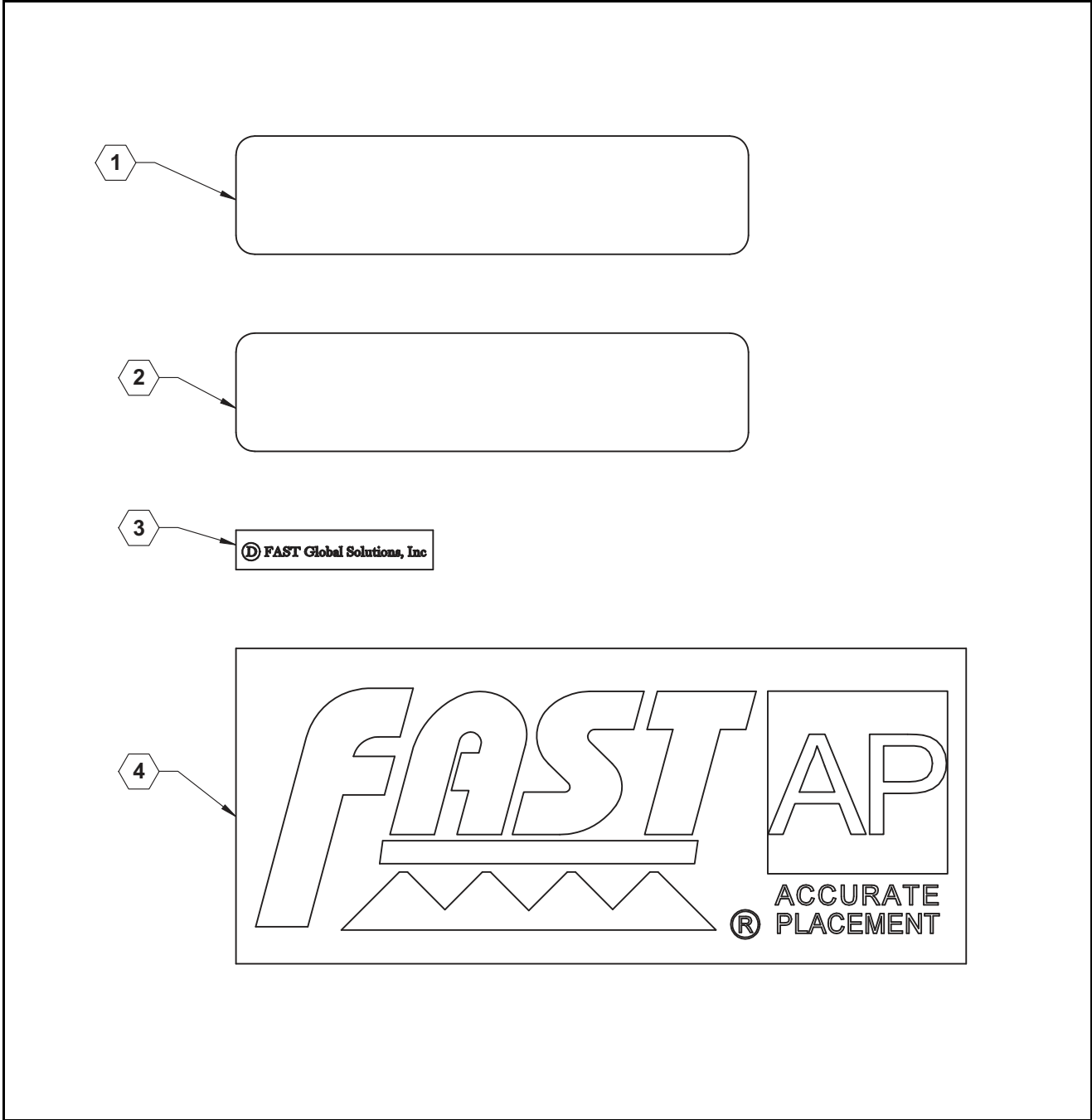



ILLUSTRATED PARTS LIST

Coulter Decal Assembly Parts List

ITEM	PART NO.	QTY.	DESCRIPTION
1	800197	1	SHANK PATENT DECAL
2	800198	1	DECAL, UPPER MOUNT PATENT
3	800209	1	DECAL, D FAST GLOBAL SOLUTIONS
4	800210	1	DECAL, FAST AP COULTER LOGO



ILLUSTRATED PARTS LIST

Ace 150-206 Pump Hydraulic Motor

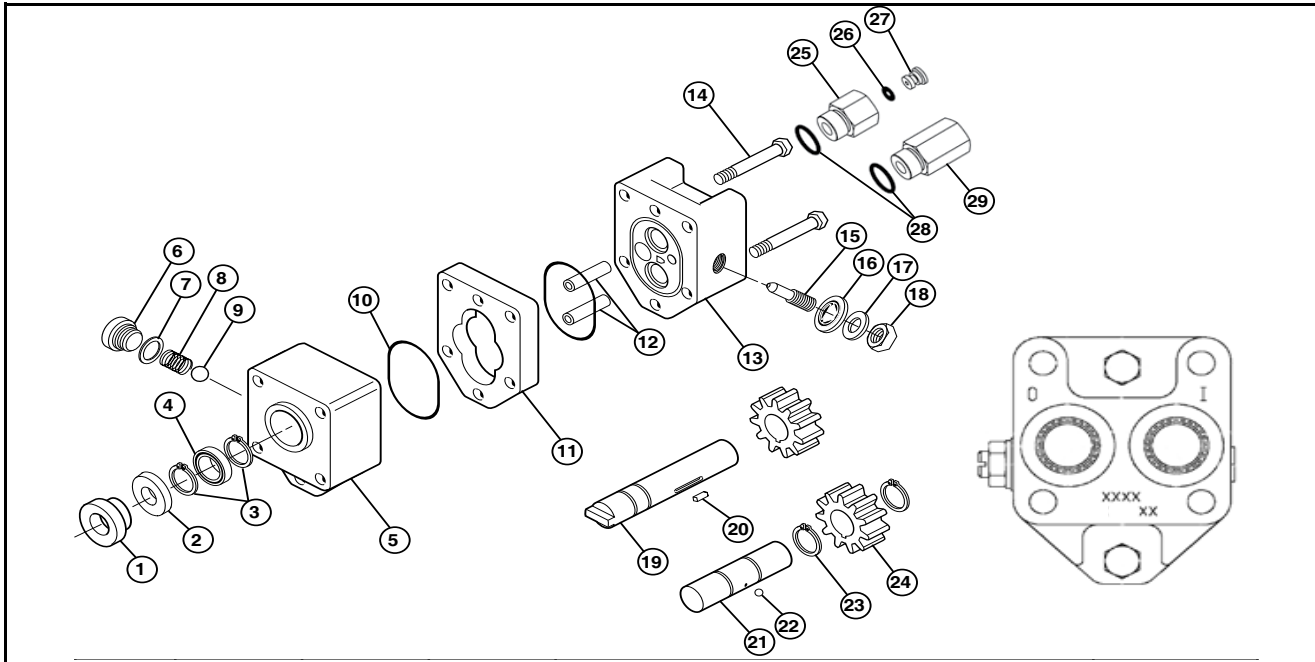

Ace 150-206 Pump Hydraulic Motor Parts List

ITEM	MODEL 204N	MODEL 206N	MODEL 210N	DESCRIPTION	QTY.
1*	S200	S200	S200	SEAL SUPPORT SPACER	1
2*	40153	40153	40153	SEAL CARTRIDGE	1
3	41941	41941	41941	SNAP RING, BEARING	2
4	41961	41961	41961	BALL BEARING, 7/16" I.D.	1
5	41731	41731	41731	DRIVE PLATE	1
6	42041	42041	42041	VALVE CAP, COASTING CHECK	1
7*	42044	42044	42044	"O" RING, COASTING CHECK	1
8	42042	42042	42042	SPRING, COASTING CHECK	1
9	42043	42043	42043	BALL, COASTING CHECK	1
10*	41850	41850	41850	"O" RING, HOUSING SEAL	2
11	41720	41721	41725	GEAR HOUSING	1
12	41800	41801	41805	DOWEL PIN, HOUSING	2
13	41742	41742	41742	END PLATE	1
14	41900	41900	41905	CAP SCREW, 1/4" N.C. HEX HEAD	2
15	42010	42010	42010	ADJUSTING SCREW, NEEDLE VALVE	1
16*	42030	42030	42030	THREAD SEAL, 3/8", NEEDLE VALVE	1
17	42040	42040	42040	WASHER, FLAT STEEL, NEEDLE VALVE	1
18	40960	40960	40960	NUT, 3/8" N.C. JAM, NEEDLE VALVE	1
19	41761	41764	41766	DRIVE SHAFT	1
20	41920	41921	41925	DOWEL PIN, DRIVE SHAFT	1
21	41970	41971	41975	IDLER SHAFT	1
22	41990	41990	41990	BALL, IDLER SHAFT	1
23	41980	41980	41980	RETAINING RING, IDLER GEAR	2
24	41750	41751	41755	GEAR	2
25	41455	41455	41455	ADAPTER BODY, #8 SAE MALE X 1/2" NPT	1
26	41448	41448	41448	"O" RING, ORIFICE INSERT (USE WITH 41456 INSERT)	1
27	41457	41456	41456	INSERT, RESTRICTOR ORIFICE (USE WITH 41455 BODY)	1
28	41875	41875	41875	"O" RING, #8 SAE MALE FITTING	2
29	41441	41441	41441	REVERSE CHECK, #8 SAE MALE X 1/2" NPT	1
#	41374	41374	41374	REPAIR KIT, RK-BAC-75-HYD-L	--



ILLUSTRATED PARTS LIST

Ace 150-206 Pump

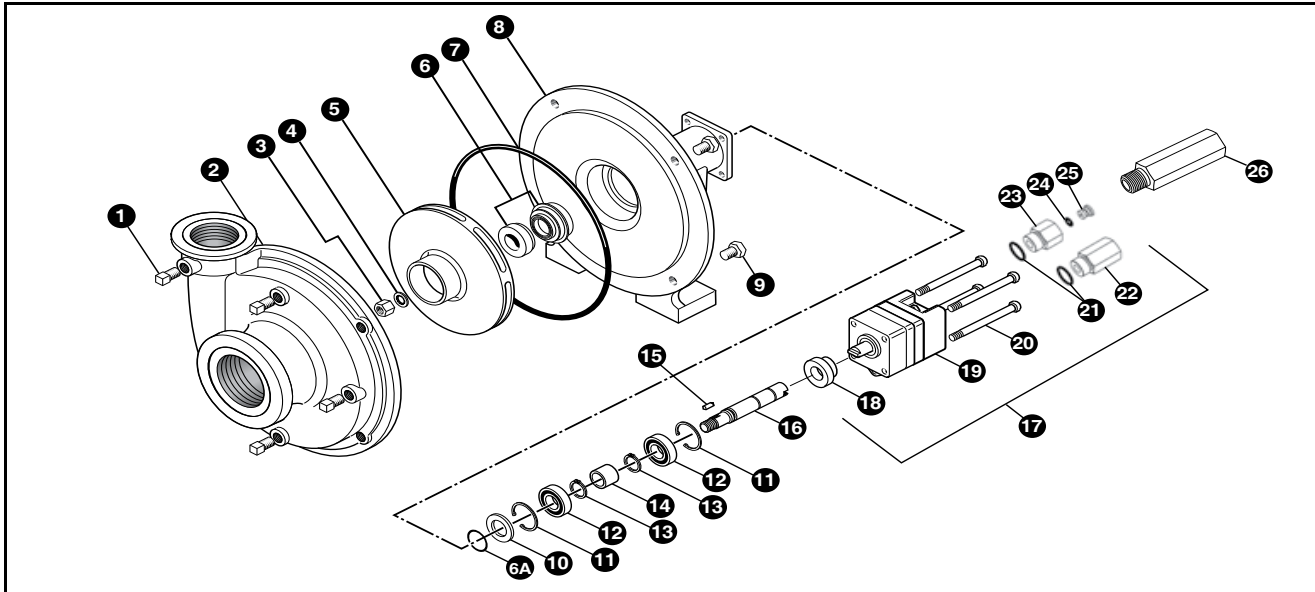

Ace 150-206 Pump Parts List

ITEM	PART NO.	EDP NO.	DESCRIPTION	QTY.
1	BAC-53	41110	PIPE PLUG	4
1	41120	41120	PIPE PLUG, STAINLESS STEEL (OPTIONAL)	4
2	BAC-12-150-FLG	40257	VOLUTE, CAST IRON, NPT & ?ANGED (FOR 150F MODELS)	1
2	BAC-12-150-SS	40249	VOLUTE, 316 STAINLESS STEEL , NPT & ?ANGED (FOR 150FS MODELS)	1
3	BAC-23-A	40391	NUT, 3/8" NF, CAD PLATED	1
3	BAC-23-A-SS	40392	NUT, 3/8" NF, STAINLESS STEEL (OPTIONAL)	1
4 (*)(**)	BAC-24-HYD-SS	40400	WASHER, 3/8" STAR, STAINLESS STEEL	1
5	BAC-26-150-P	40446	IMPELLER, VALOX, KEYWAY	1
5	BAC-26-150-CI	40445	IMPELLER, CAST IRON, KEYWAY (OPTIONAL)	1
6 (*)	BAC-7V	40151	SEAL, CARBON/CERAMIC/VITON (INCLUDES 40160 O-RING)	1
6 (**)	BAC-7SC	40152	SEAL, SILICON CARBIDE/VITON (INCLUDES 40160 O-RING) (OPTIONAL)	1
6A (*)(**)	40160	40160	O-RING, SHAFT SEAL	1
7 (*)(**)	BAC-4-150	40015	O-RING, BODY SEAL	1
8	BAC-14-150-HYD	40305	MOUNTING FRAME, CAST IRON (FOR 150F MODELS)	1
8	BAC-14-150-HYD-SS	40319	MOUNTING FRAME, 316 STAINLESS STEEL (FOR 150FS MODELS)	1
9	40950	40950	CAP SCREW, 3/8" NC X 3/4" HEX HEAD	4
9	40930	40930	CAP SCREW, 3/8" NC X 3/4" HEX HEAD, STAINLESS STEEL (OPTIONAL)	4
10	BAC-54	41130	SLINGER	1
11	BAC-33	40810	SNAP RING, INTERNAL, BAC-14 MOUNTING FRAME	2
12	BAC-37	40870	BALL BEARING, SEALED, BAC-6 SHAFT	2
13	BAC-32	40790	SNAP RING, EXTERNAL, BAC-6 SHAFT	2
14	BAC-32-S	40795	SPACER FOR BAC-6 SHAFT	1
15	BACH-25	40420	KEY, 1/8" X 1/8" X 1/2"	1
16	BAC-6-HYD-SS	40061	SHAFT, 5/8" DIAMETER, KEYWAY AND TANG SLOT, STAINLESS STEEL	1
17	BAC-75-HYD-206	41372	HYDRAULIC MOTOR, 7 GPM (INCLUDES PARTS 18 - 25)	1
18	S200	40161	SEAL SUPPORT SPACER FOR 200 SERIES HYD MOTOR	1
19	BAC-75-HYD-206N	41397	HYDRAULIC MOTOR, 7 GPM (MOTOR ONLY - NO EXTERNAL ?TTINGS)	1
20	41255	41255	CAP SCREW, 5/16" N. C. X 3-3/4" SOCKET HEAD (FOR 206N MOTOR)	4
21	41875	41875	"O" RING, #8 SAE MALE FITTING	2
22	BAC-78-8SAE	41441	REVERSE CHECK, #8 SAE MALE X 1/2" NPT	1
23	BAC-80-8SAE	41455	ADAPTER BODY, #8 SAE MALE X 1/2" NPT	1
24	41448	41448	"O" RING, ORIFICE INSERT (USE WITH 41456 INSERT)	1
25	BAC-79-7	41456	INSERT, RESTRICTOR ORIFICE (USE WITH 41455 BODY)	1
26	LS-206N	41418	FLOW LIMITING VALVE (206N), #8 SAE MALE X 1/2" NPT FEMALE	1
*	RK-FMC-150	52710	REPAIR KIT FOR FMC-150 SERIES PUMP	-
**	RK-FMCSC-150	52711	REPAIR KIT FOR FMC-150 SERIES WITH SILICON CARBIDE SHAFT SEAL	-
#	RK-BAC-75-HYD-L	41374	REPAIR KIT, RK-BAC-75-HYD-L	-

Ace 304 Pump

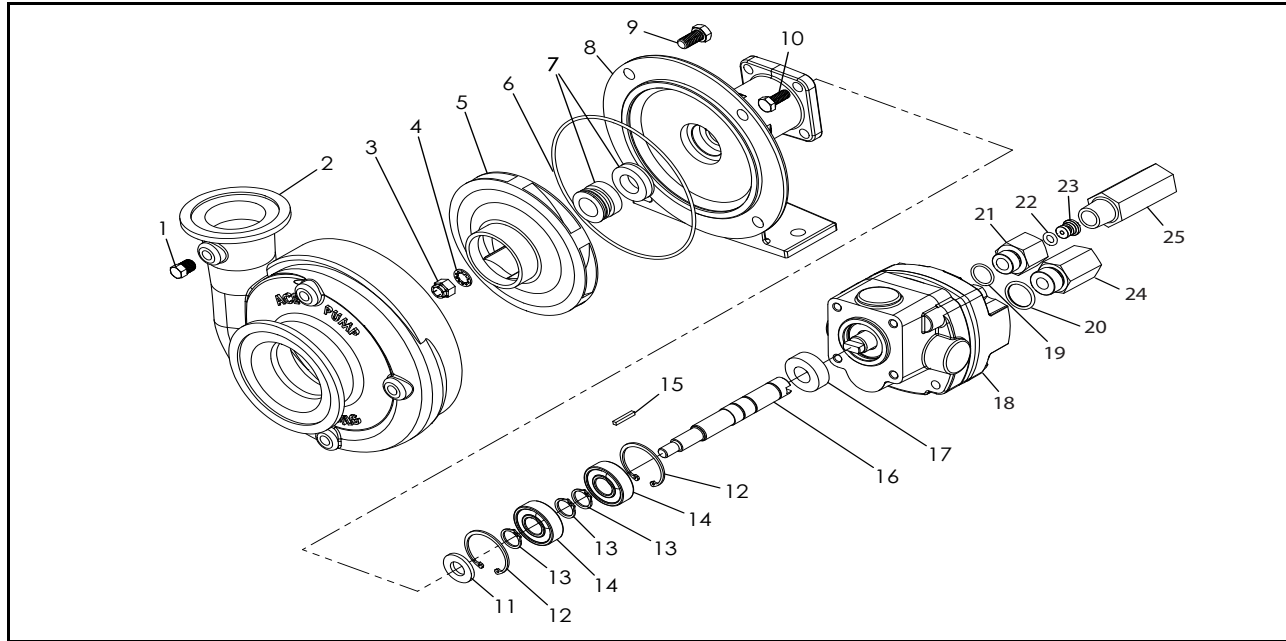

Ace 304 Pump Parts List

ITEM	PART NO.	PART NO.	QTY.	DESCRIPTION
	Model 304N	Model 310N		
1	40162	40162	1	SEAL SUPPORT SPACER, S300 FOR 200 SERIES PUMPS
1	40163	40163	1	SEAL SUPPORT SPACER, S305 FOR 205 SERIES PUMPS
2*	40154	40154	1	SEAL CARTRIDGE, BAC-75-300-TLS
3	43056	43056	1	SPACER SEAL/BEARING, PERFORATED, 300 SERIES MOTOR
4	43205	43205	2	RETAINING RING, BEARING
5	43225	43225	1	BALL BEARING
6	43016	43016	1	DRIVE PLATE
7*	43130	43130	2	O-RING, HOUSING SEAL
8	43085	43080	2	DOWEL PIN, HOUSING
9	43005	43000	1	GEAR HOUSING
10	43277	43277	1	CAP, NEEDLE VALVE WITH O-RING, 300N SERIES MOTOR
11*	43276	43276	1	O-RING, NEEDLE VALVE CAP
12	43266	43266	1	NEEDLE, 300N SERIES MOTOR
13	43022	43022	1	END PLATE, 300N SERIES MOTOR
14	43185	43180	4	CAP SCREW, 3/8" N.C. HEX HEAD
15	43240	43240	2	RETAINING RING, GEAR
16	43035	43030	2	GEAR
17	43250	43250	1	BALL, IDLER SHAFT
18	43235	43230	1	IDLER SHAFT
19	43046	43039	1	DRIVE SHAFT
20	43195	43190	1	DOWEL PIN, DRIVE SHAFT
21	41455	41455	1	ADAPTER BODY, #8 SAE MALE X 1/2" NPT
22	41448		1	"O" RING, ORIFICE INSERT (USE WITH 41456 INSERT)
23	41447		1	ORIFICE INSERT, RESTRICTOR INSERT
24	41875	41875	1	"O" RING, #8 SAE MALE FITTING
25	41445	41445	1	O-RING, #10 SAE FITTING
26	41442	41442	1	REVERSE CHECK ASSEMBLY, #10 SAE X 1/2" NPT
*	41362	41362	AR	MOTOR REPAIR KIT, INCLUDES 2, 7, 11



ILLUSTRATED PARTS LIST



FAST GLOBAL
SOLUTIONS

ACE 150-206 Pump, Self Priming

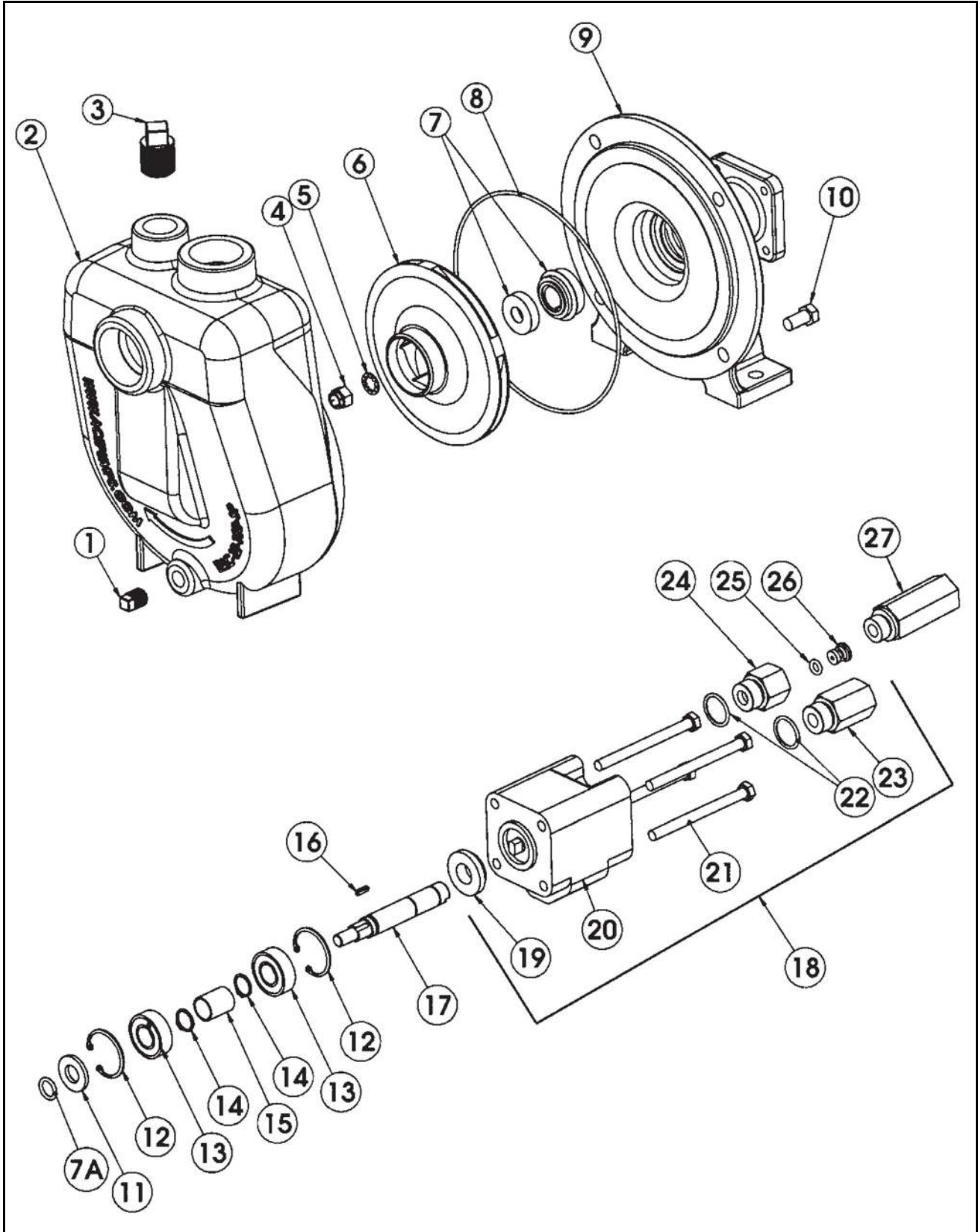



ILLUSTRATED PARTS LIST

ACE 150-206 Pump, Self Priming Parts List

ITEM	VENDOR PART NO.	EDP PART NO.	QTY.	DESCRIPTION
1	20750	20750	1	Pipe plug, drain, 1/4" NPT
2	BAC-12-150-SP	40254	1	Volute, self-priming, 1-1/2" x 1-1/4"
3	41105	41105	1	Pipe plug, fill, 3/4" NPT
4	BAC-23-A	40391	1	Nut, 3/8" NF, cad plated
4	BAC-23-B-SS	40393	1	Nut, 3/8" NF, stainless steel (standard on -SS models)
5 (*1*2)	BAC-24-HYD-SS	40400	1	Washer, 3/8" star, stainless steel
5	BAC-24-B-SS	42702	1	Washer, 3/8", stainless steel, vibration proof (standard on -SS models)
6	BAC-26-150-P	40446	1	Impeller, Valox, keyway
6	BAC-26-150-CI	40445	1	Impeller, cast iron, keyway (optional)
6	BAC-26-150-PI	40448	1	Impeller, polypropylene, keyway (optional)
7 (*1)	BAC-7V	40151	1	Seal, carbon/ceramic/Viton (includes 40160 O-ring)
7 (*2)	BAC-7SC	40152	1	Seal, silicon carbide/Viton (includes 40160 O-ring) (optional)
7A (*1*2)	40160	40160	1	O-ring, shaft seal
8 (*1*2)	BAC-4-150	40015	1	O-ring, body seal
9	BAC-14-150-HYD	40305	1	Mounting frame (for 200 Series hydraulic motor)
10	40950	40950	4	Cap screw, 3/8" NC x 3/4" hex head
10	40930	40930	4	Cap screw, 3/8" NC x 3/4" hex head, stainless steel (optional)
11	BAC-54	41130	1	Slinger
12	BAC-33	40810	2	Snap ring, internal, BAC-14 mounting frame
13	BAC-37	40870	2	Ball Bearing, sealed, BAC-6 shaft
14	BAC-32	40790	2	Snap ring, external, BAC-6 shaft
15	BAC-32-S	40795	1	Spacer for BAC-6 shaft
16	BACH-25	40420	1	Key, 1/8" x 1/8" x 1/2"
17	BAC-6-HYD-SS	40061	1	Shaft, 5/8" diameter, keyway and tang slot, stainless steel
18	BAC-75-HYD-206	41372	1	Hydraulic motor, 7 GPM (includes parts 19 - 26)
19	S200	40161	1	Seal support spacer for 200 Series HYD motor
20	BAC-75-HYD-206N	41397	1	Hydraulic motor, 7 GPM (motor only - no external fittings)
21	41255	41255	4	Cap screw, 5/16" N. C. x 3-3/4" socket head (for 206N motor)
22	41875	41875	2	O-ring, #8 SAE fitting
23	BAC-78-8SAE	41441	1	Reverse check assembly, #8 SAE male x 1/2" NPT female
24	BAC-80-8SAE	41455	1	Body, restrictor orifice, #8 SAE male x 1/2" NPT female
25	41448	41448	1	O-ring, orifice insert
26	BAC-79-7	41456	1	Orifice, restrictor insert, .109 (206N)
27	LS-206N	41418	1	Flow limiting valve (206N), #8 SAE male x 1/2" NPT female
*1	RK-FMC-150	52710	1	Repair kit for FMC-150 series pump
*2	RK-FMCSC-150	52711	1	Repair kit for FMC-150 series with silicon carbide shaft seal
#	RK-BAC-75-HYD-L	41374	1	Repair kit for 200 Series motor with high pressure lip seal

Hypro Pump

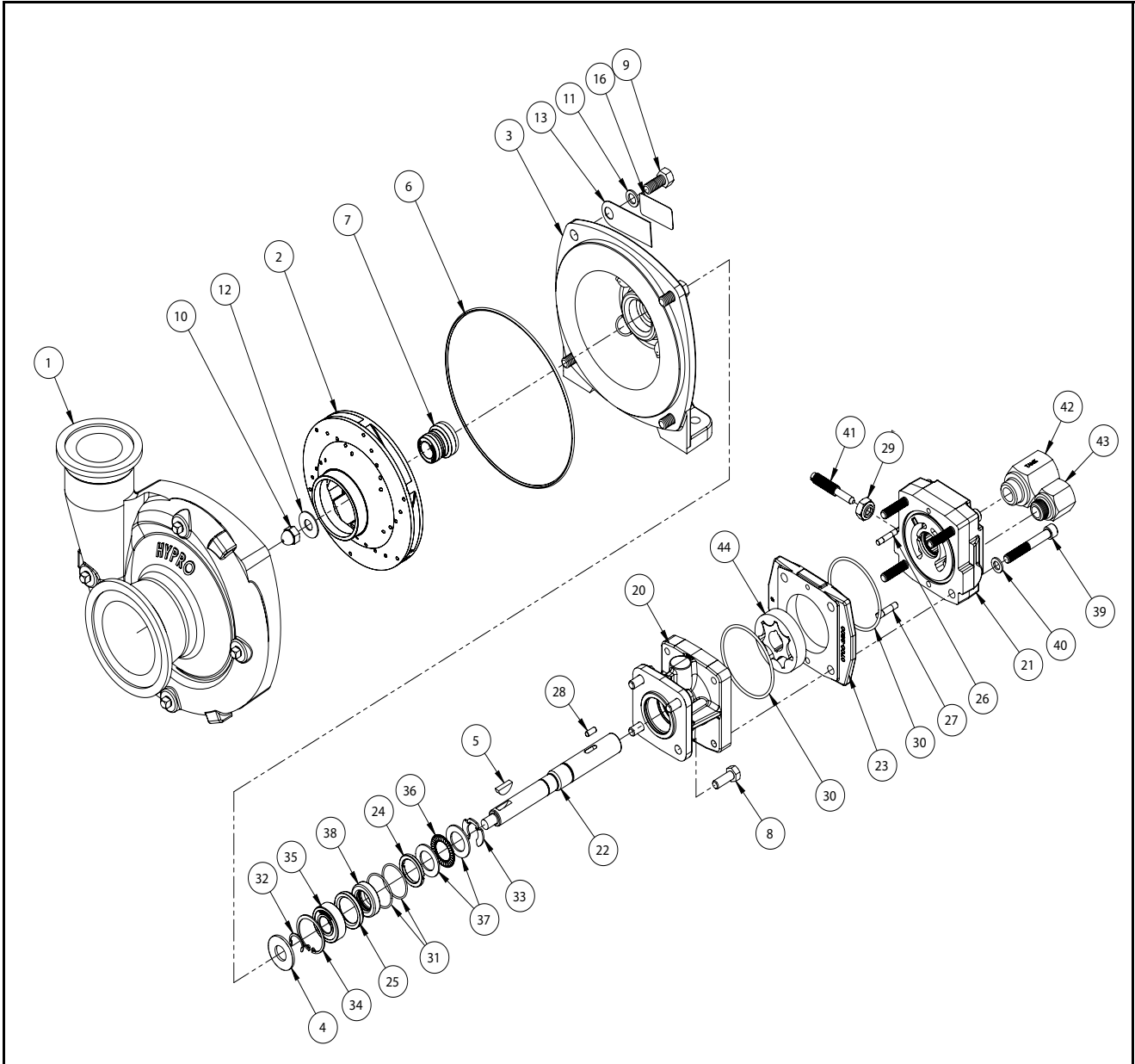



ILLUSTRATED PARTS LIST

Hypro Pump Parts List

ITEM	PART NO.	QTY.	DESCRIPTION
1	0158-9200C	1	PUMP HOUSING, 300x220 U.FLG
2	0401-9200P2	1	IMPELLER (CW ROTATION)
3	0750-9300C2	1	MOUNTING FLANGE
4	1410-0056	1	SLINGER SEAL
5	1610-0012	1	WOODRUFF KEY
6	1720-0083	1	O-RING
7	2120-0039	1	SEAL, MECHANICAL
8	2210-0005	4	CAP SCREW, HEX HEAD 5/16"-18 X 7/8"
9	2210-0020	4	CAP SCREW, HEX HEAD 3/8"-16 X 7/8"
10	2253-0002	1	ALCNUT 0.3750-24-N
11	2270-0041	1	WASHER
12	2270-0071	1	IMPELLER WASHER
13	2270-0076	1	TAG
14	3031-0134	1	CARTON - INDIVIDUAL
15	3435-0171	1	PACKING KIT
16	6031-0325	1	DECAL
17	6031-0340	1	LABEL READY FOR ROUND UP
18	6031-0343	1	INSTRUCTION TAG
19	6031-0373	1	CE STICKER LABEL
20	0150-2500C	1	BODY ASSY-SMALL PILOT
21	0254-2500C2	1	END PLATE ASSY
22	0533-2500	1	SHAFT
23	0700-2500C1	1	GEROTOR HOUSING HM1, COATED
24	1410-0130	1	SPACER, 3L SEAL
25	1410-0131	1	CARTRIDGE, FRONT
26	1600-0037	1	DOWEL PIN
27	1600-0044	1	DOWEL PIN
28	1610-0031	1	HM1 & HM5 Round Key
29	1700-0245	1	NUT, SEALING
30	1720-0110	2	O-RING
31	1720-0268	2	O-RING
32	1810-0014	1	RETAINING RING
33	1810-0026	1	RETAINING RING
34	1820-0013	1	INT. RET. RING
35	2000-0010	1	BEARING, BALL
36	2029-0009	1	BEARING, THRUST
37	2029-0010	2	BEARING RACE, THRU
38	2104-0010	1	LIP SEAL
39	2220-0021	4	SCREW, SOCKET HEAD
40	2270-0039	4	WASHER, FLAT 5/16"
41	3220-0029	1	VALVE STEM
42	3320-0052A	1	CHECK VALVE ASSY - TANK PORT
43	3360-0023A	1	ADAPTER-INLET PORT ASSY
44	3900-0022	1	GEROTOR

Ball Valve Mount

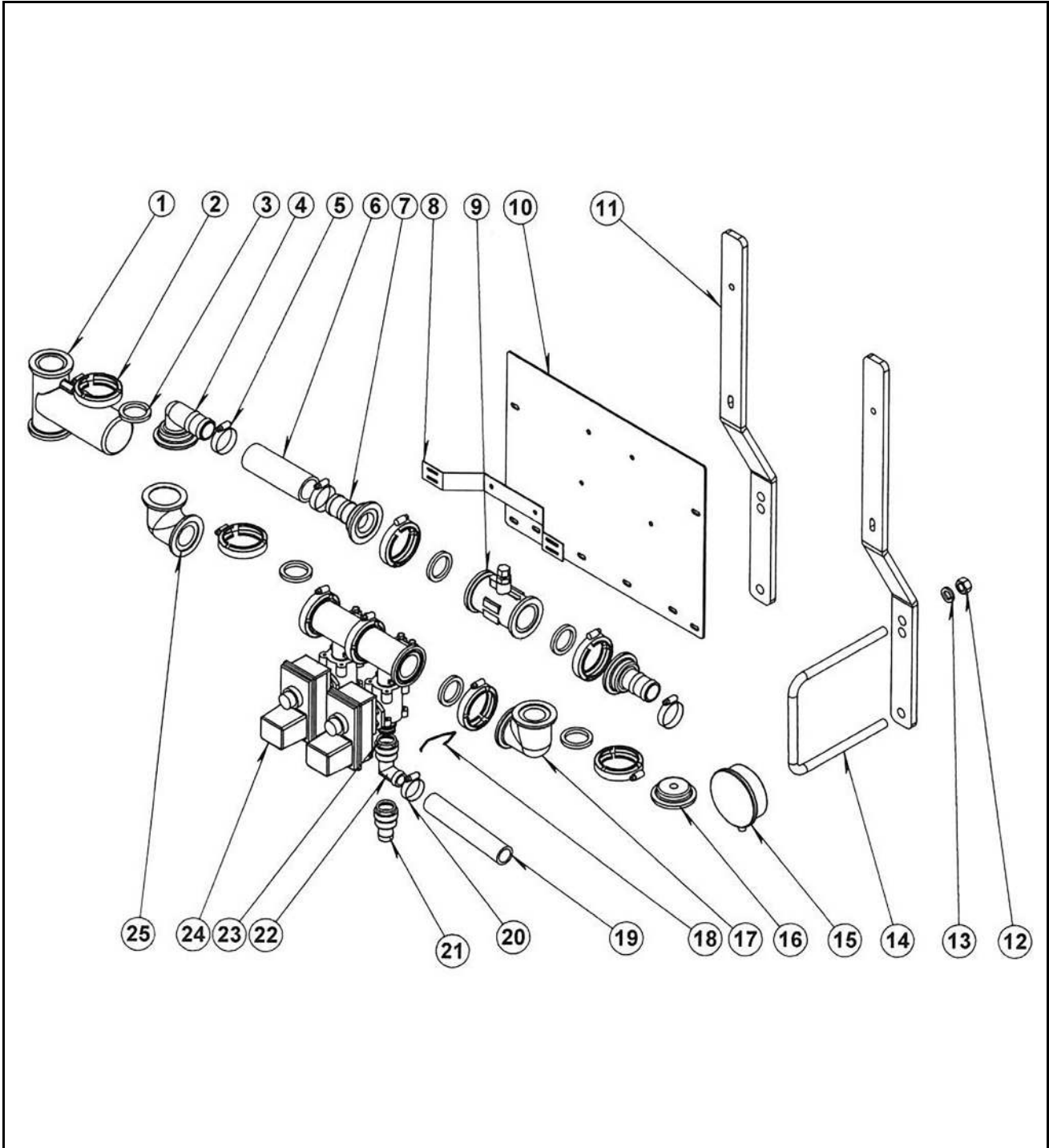



ILLUSTRATED PARTS LIST

Ball Valve Mount Parts List

ITEM	PART NO.	VENDOR PART NO.	QTY.	DESCRIPTION
1	631805	063-0171-894	1	CONTROL VALVE 1-1/2
2	540001	FC200	AR	CLAMP 2" STD PORT
3	530014	M150G	AR	GASKET 2" STD PORT
4	530080	M200150BRB90	1	MANIFOLD HOSE BARB 90
5	540016	64024	2	CLAMP, STAINLESS 1-1/2"
6	510014	1-1/2BH200	AR	HOSE 1-1/2" EPDM
7	530049	M200150BRB	1	MANIFOLD 2" STD TO HOSE BARB
8	631809		1	BRACKET, FLOW METER
9	631804	063-0171-793	1	FLOW METER 60P
10	3179		1	PANEL, CONTROLLER MOUNT
11	5729		2	MOUNT, BALL VALVE
12	216		4	NUT, HEX 5/8" ZP
13	253		4	WASHER, LOCK 5/8" ZP
14	590108		2	U-BOLT 7 X7 BAR
14	596772M		2	U-BOLT 4 X6 BAR
15	790020	FAST4154GXX160	1	GAUGE, FAST LOGO 160 PSI
16	530094	M200PLG025	1	MANIFOLD PLUG WITH 1/4" PORT
17	530089	M200CPG90SH	1	MANIFOLD ELBOW 90 SHORT
18	530193	CP37166-1-302SS	AR	RETAINING CLIP
19	510016	1BH200	AR	HOSE 1" EPDM
20	540016	64016	AR	CLAMP 1" HOSE
21	530189		AR	QUICK CONNECT STRAIGHT
22	530190	45529-1	AR	QUICK CONNECT 90 DEGREE
23	530198	CP7717-3-912-VI	AR	O-RING, VITON
24	500027		AR	VALVE 450BEC MANIFOLD (NARROW) (NON-FLOWBACK)
24	500028		AR	VALVE 450BEC MANIFOLD (WIDE) (NON-FLOWBACK)
24	500029	45*BEC	AR	VALVE 450BEC MANIFOLD (WIDE) (FLOWBACK)
25	530088	M200CPG90	1	MANIFOLD ELBOW, 90 DEGREE

Toolbar Plumbing

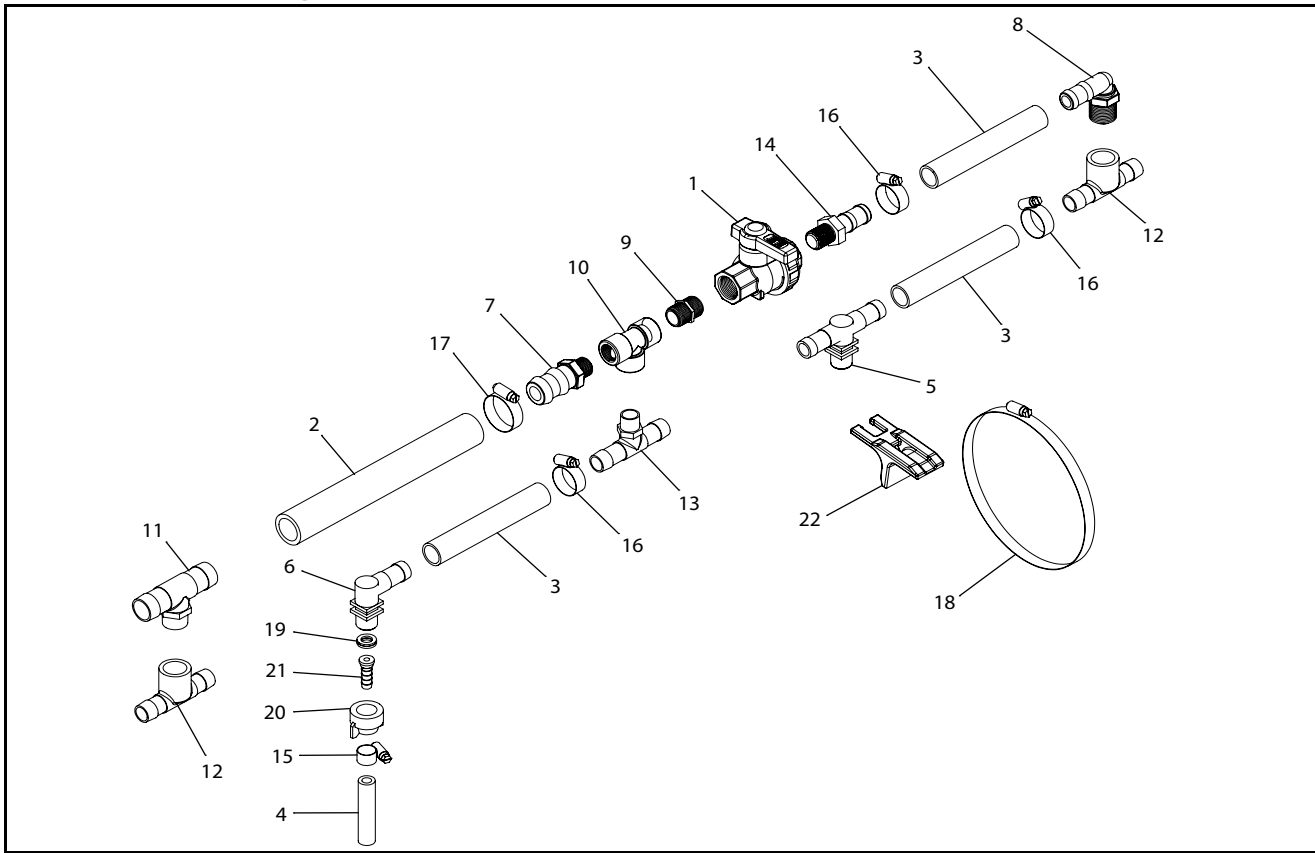

Toolbar Plumbing Parts List

ITEM	PART NO.	QTY.	DESCRIPTION
1	500043	AR	VALVE, 3/4"
2	510016	AR	HOSE, 1" EPDM
3	510019	AR	HOSE, 3/4", EPDM
4	510020	AR	HOSE, 3/8", EPDM
5	520003	AR	NOZZLE, SINGLE
6	520004	AR	NOZZLE, DOUBLE
7	530039	AR	3/4" MPT X 1" HOSE BARB
8	530040	AR	3/4" MPT X 3/4" HOSE BARB 90°
9	530131	AR	3/4" MPT SHORT NIPPLE
10	530156	AR	TEE 3/4" NPT
11	530181	AR	3/4" MPT X 1" HOSE BARB TEE
12	530220	AR	3/4" FPT X 3/4" HOSE BARB TEE
13	530221	AR	3/4" MPT X 3/4" HOSE BARB TEE
14	530230	AR	3/4" MPT X 3/4" HOSE BARB
15	540011	AR	CLAMP, 3/8"
16	540013	AR	CLAMP, 3/4"
17	540014	AR	CLAMP, HOSE SS 1" #16
18	540021	AR	CLAMP, 4 1/8 - 7"
19	590029	AR	SEAL, EPDM
20	590076	AR	CAP
21	590077	AR	CONNECTOR, HOSE BARB
22	590187	AR	MOUNT, PLUMBING

Raven Components

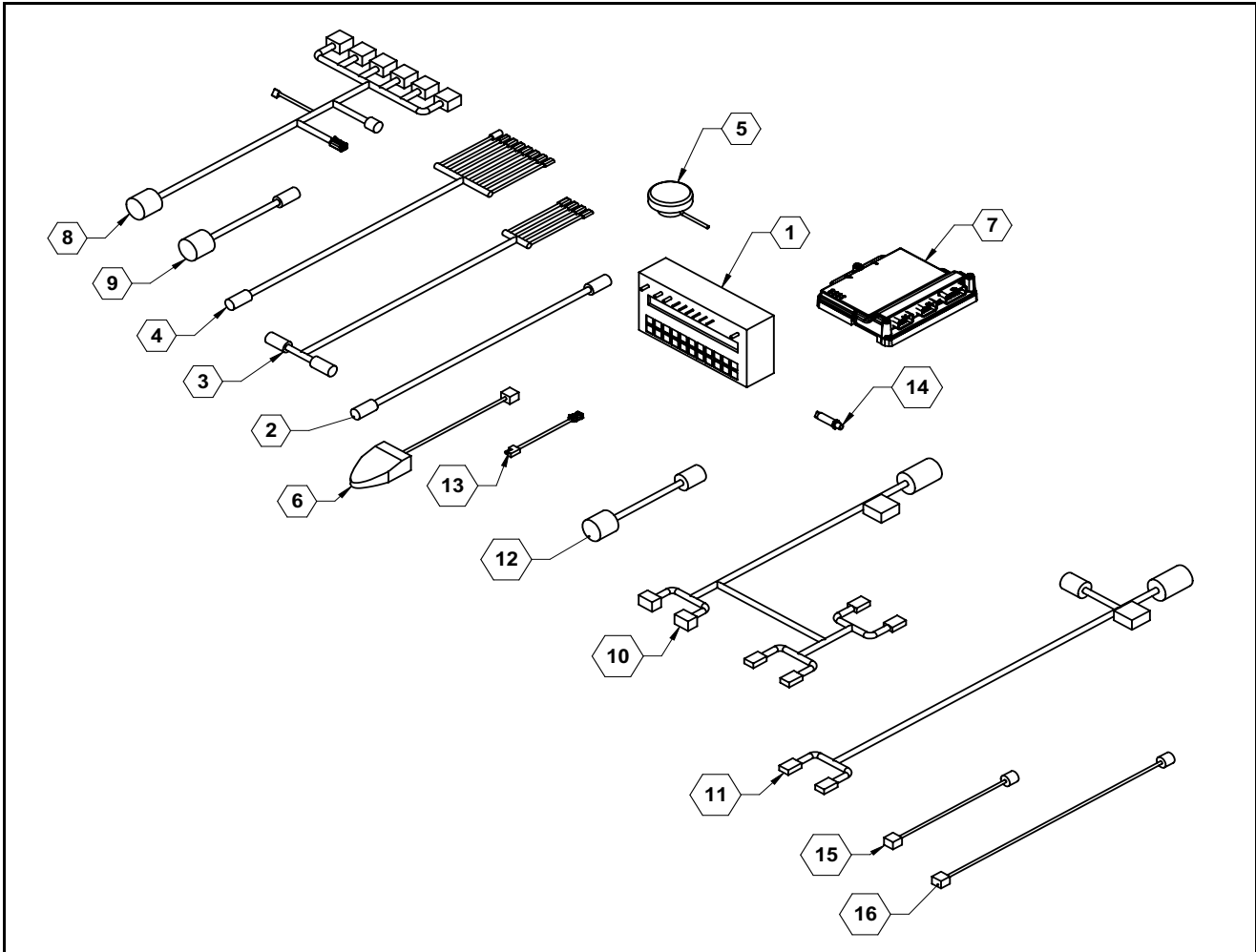

Raven Components

ITEM	PART NO.	QTY.	DESCRIPTION
1	631803	AR	6 SECTION 450 CONSOLE
2	631814	AR	12' 16 PIN EXTENSION CABLE
3	631818	AR	10' 440/450 CONSOLE CABLE
4	631819	AR	16 PIN 6 SECTION CABLE
5	631832	AR	GPS SPEED SENSOR
6	631856	AR	FOOTSWITCH
7	632010	AR	RCM
8	632027	AR	47 PIN 6 SECTION CABLE
9	632028	AR	47 PIN TO 16 PIN ADAPTER
10	632029	AR	47 PIN RCM Y-CABLE
11	632031	AR	12' ISO TO IBIC CABLE
12	632033	AR	47 PIN TO 37 PIN ADAPTER
13	632034	AR	TRAILER TO DEUTSCH PLUG ADAPTER CABLE
14	632036	AR	PRESSURE TRANSDUCER
15	632061	AR	CABLE, FOOTSWITCH, 12'
16	632062	AR	CABLE, FOOTSWITCH, 23'
NS	631802	AR	3 SECTION 440 CONSOLE



ILLUSTRATED PARTS LIST

Control Harness 155-0171-085

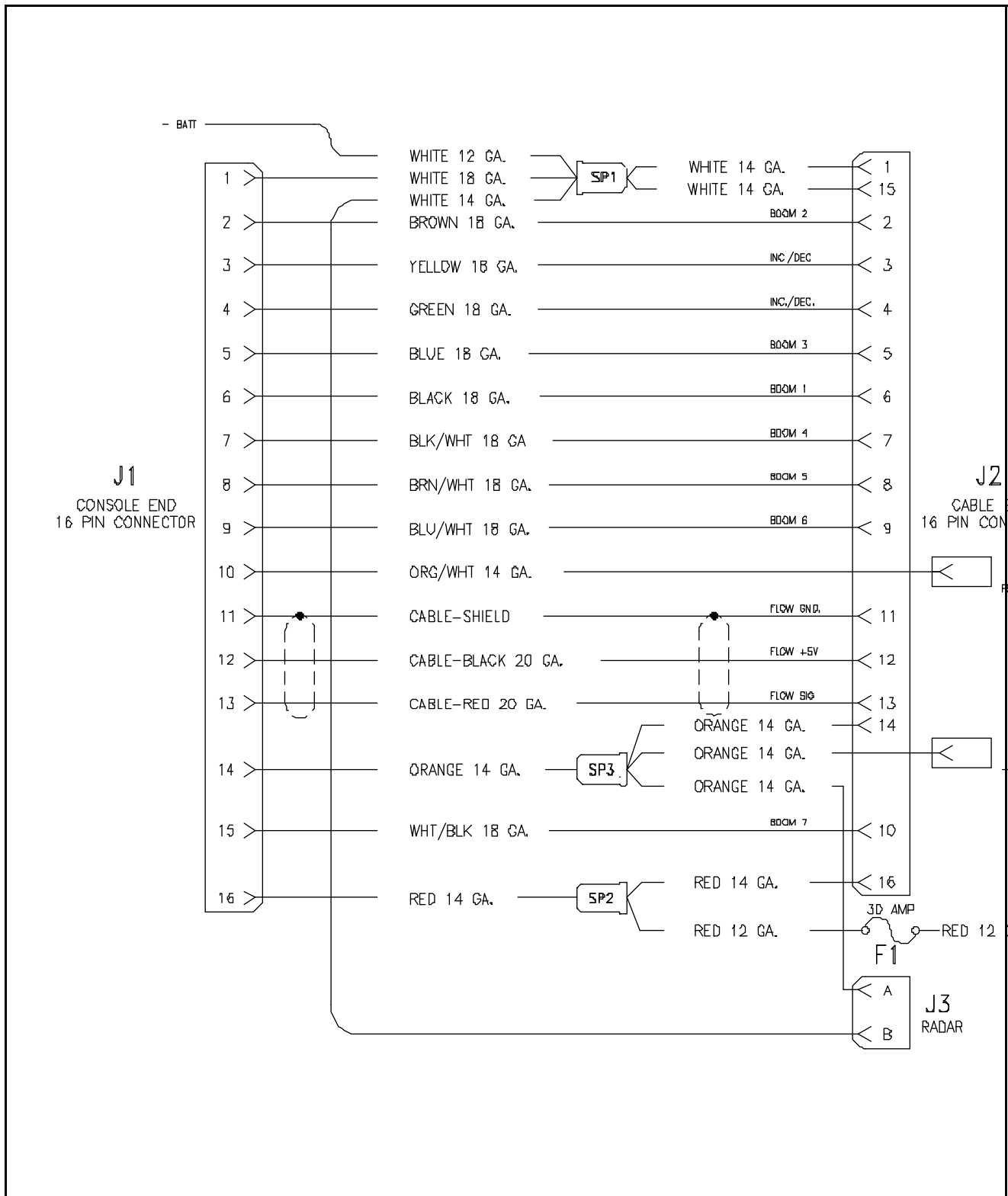



ILLUSTRATED PARTS LIST

Control Harness 155-0159-856

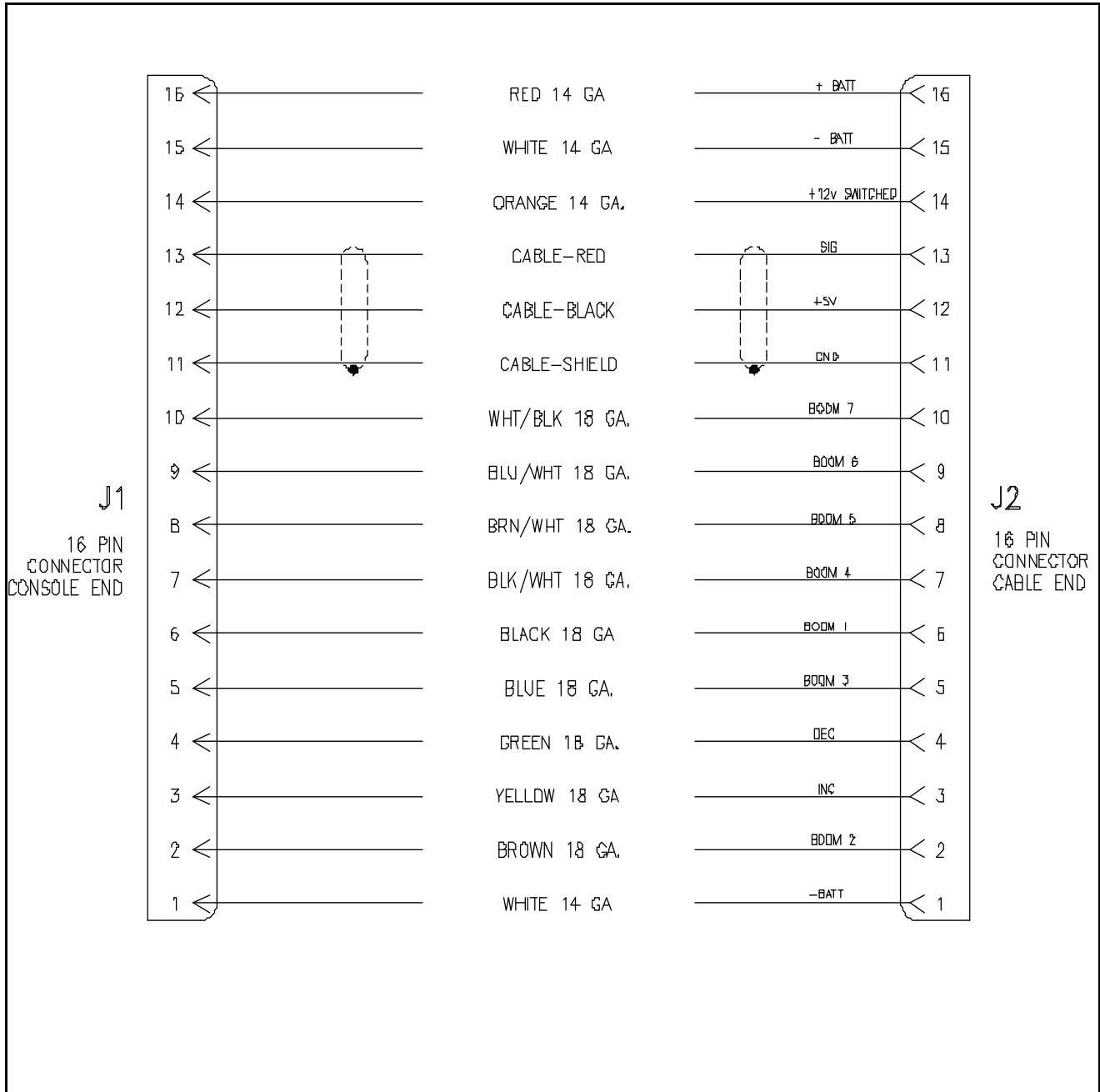



ILLUSTRATED PARTS LIST

Control Harness 155-0171-086

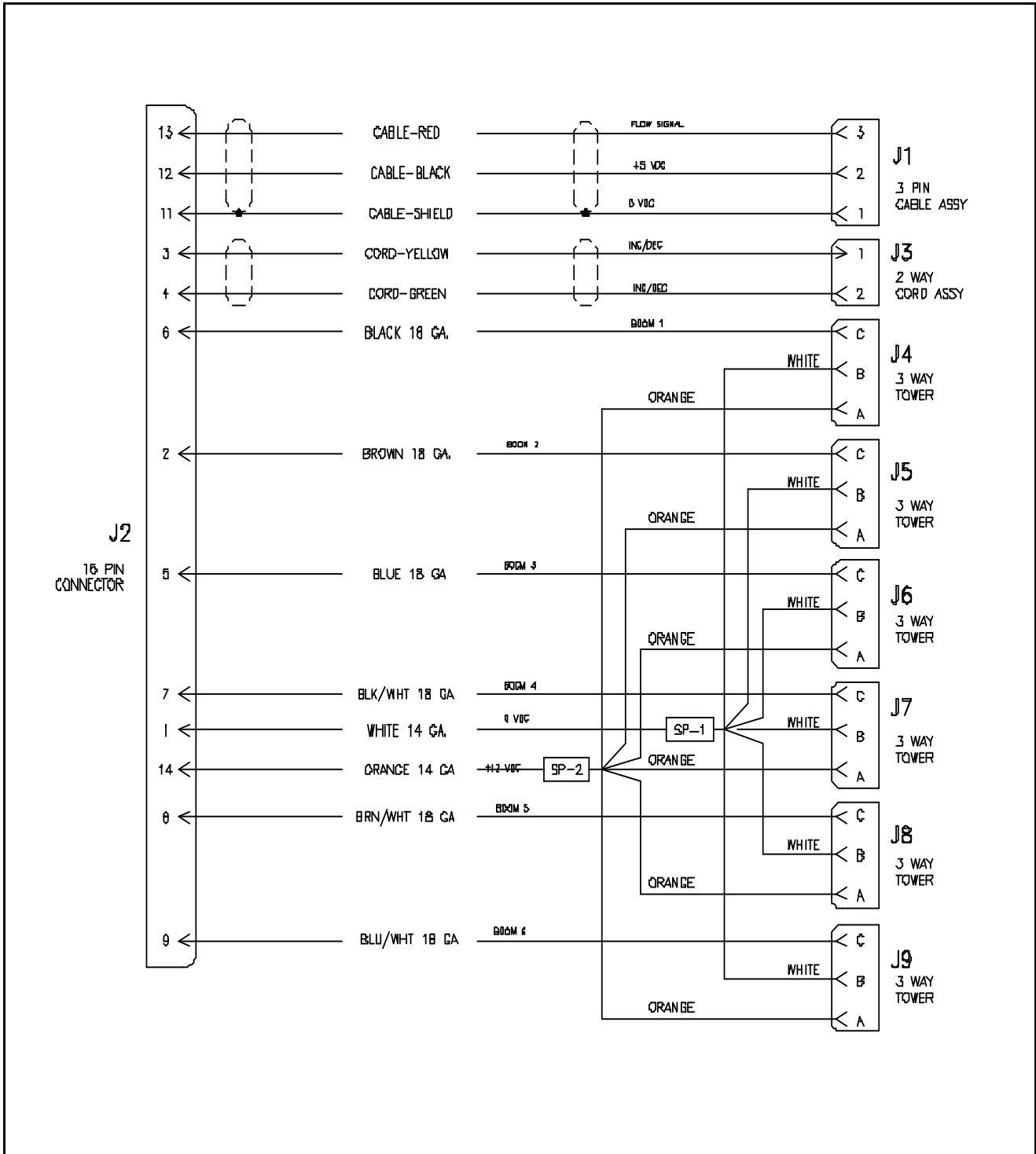

Hydraulic System for Pump

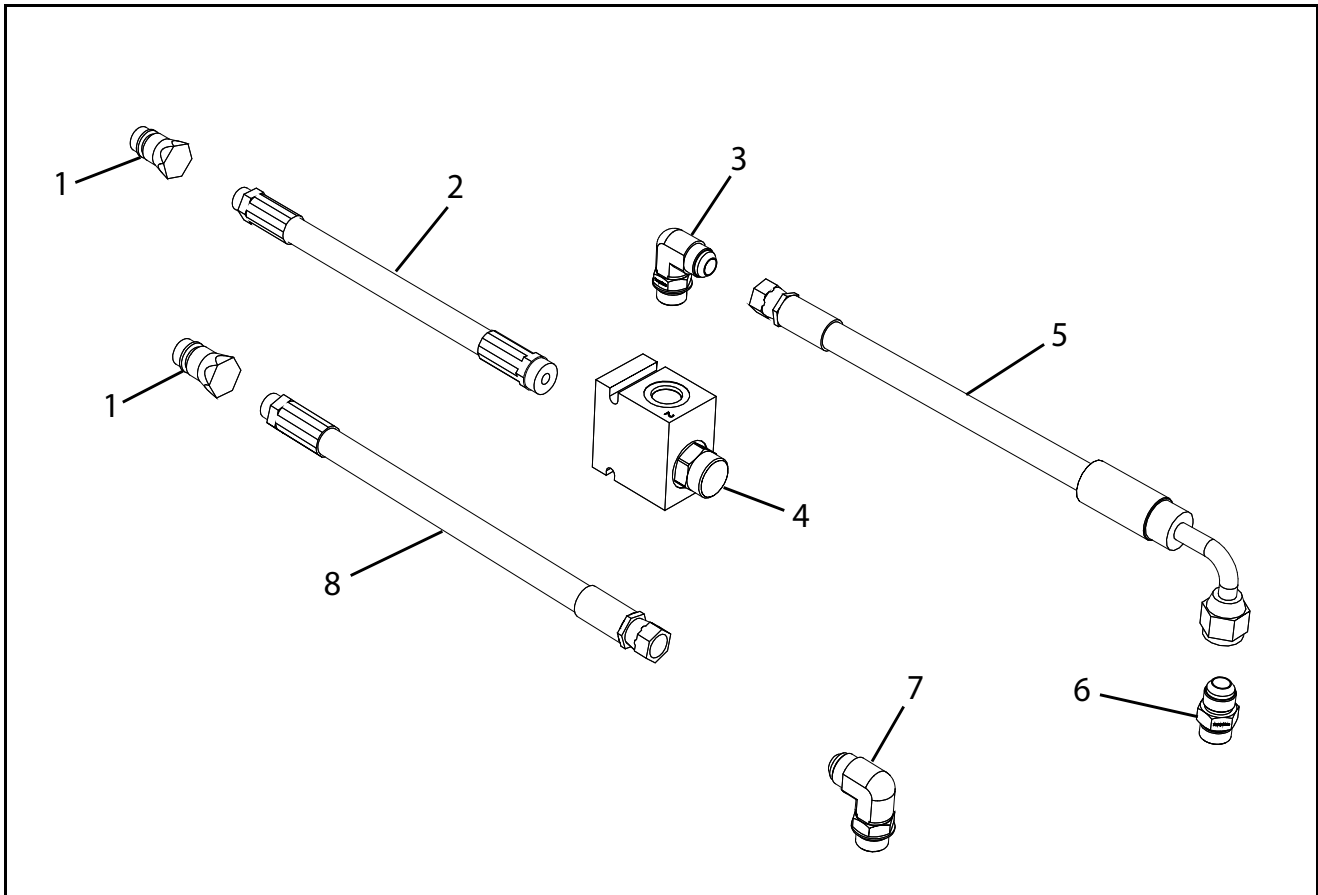

Hydraulic System for Pump Parts List

Item	Part No.	Description	8310	8313	8318	8324	Ace 150-206	Hypro 93079
1	2-NV12-12SAE	HOSE TIP	2	2	2	2		
2	PA600053-1	HOSE PRESSURE TO VALVE	1	1				
	PA600054-1	HOSE PRESSURE TO VALVE			1	1		
3	610086	HYDRAULIC FITTING 6801-8-10	1	1	1	1		
4	610100	PC VALVE 7.5 GPM					1	
	610099	PC VALVE 13 GPM						1
5	PA600053-2	HOSE PRESSURE TO PUMP	1	1				
	PA600054-2	HOSE PRESSURE TO PUMP			1	1		
6	610060	HYDRAULIC FITTING 6400-08-10	1	1				
	610106	HYDRAULIC FITTING 6400-10-10			1	1		
7	610102	HYDRAULIC FITTING 6801-10-10	1	1	1	1		
8	PA600053-3	HOSE PUMP RETURN	1	1				
	PA600054-3	HOSE PUMP RETURN			1	1		

813P Hydraulic System

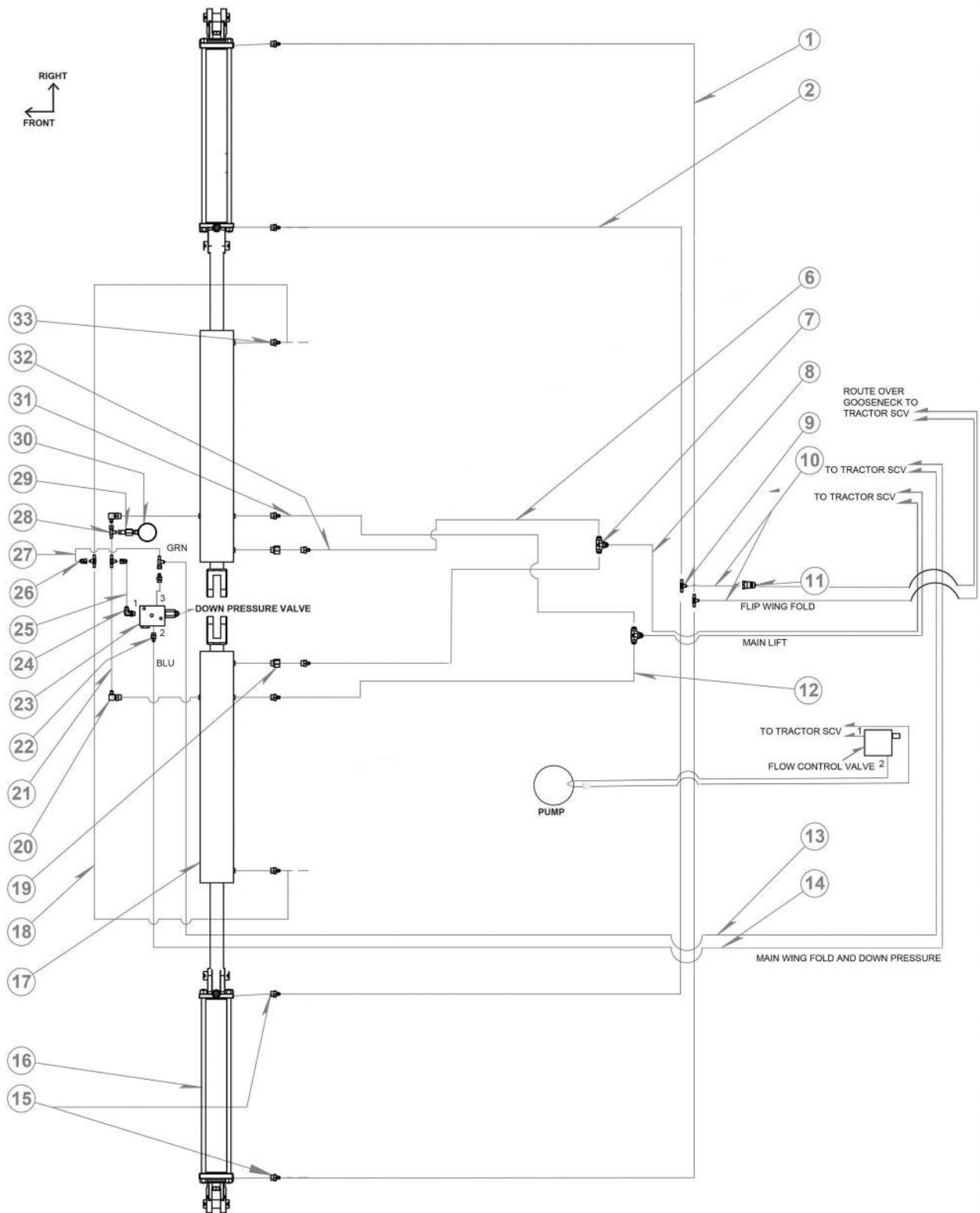



ILLUSTRATED PARTS LIST

813P Hydraulic System Parts List

Item	Vendor Part #	Part #	Description	Qty.
1		600045-7-ZN	FDM4R17-4FJXZ-4FJX90MZ-220	2
2		600045-6-ZN	FDM4R17-4FJXZ-4FJX90MZ-200	2
6		600045-10-ZN	FDM6R17-6FJX90MZ-8FJXZ-68	2
7	TO-2603-08-08-08	610004	Fitting Adapter Tee8JIC	2
8		FDM0025-ZN	FDM8R17-8MBOZ-8FJXZ-183	2
9	TO-2603-04-04-04	610003	Fitting Adapter JIC TeeTo-2603-04-04-04	2
10		FDM0055-ZN	FDM4R17-8MBOZ-4FJX90MZ-305	2
11	2-NV12-12SAE-M	520048	Tip Hydraulic ISO	6
12		600045-11-ZN	FDM6R17-6FJX90MZ-8FJXZ-80	2
13		600045-4A-ZN	FDM6R17-8MBOZ-6FJXZ-90M-281	1
14		600045-3-ZN	FDM6R17-8MBOZ-6FJXZ-273	1
15	TO-6801-6-8-S	610045	Fitting Adapter 8ORB To 4JIC R0.045 (Used On 620004)	4
16	MI671326	620057	Cylinder 30TD16-150 3" X 16" Stroke	2
NS	MI649208		Kit Seal 3.0 Bore X 1.5 Rod	AR
17		620030	CYLINDER, MAIN WING (813P)	2
NS		649080	Kit, Seal 5.0 Bore X 2.0 Rod	AR
18		FDM0048-ZN	FDM4R17-4FJXZ-4FJX90MZ-85	2
19	AF661182047	610096	Fitting Adapter 8ORB M/F .047Orifice	2
20	TO-6801-04-08	610029	Fitting Adapter 8ORB To 4JIC90°	2
21		600056-1-ZN	FDM4R17-4FJXZ-4FJXZ-63	1
22	TO-6400-06-06	610010	Fitting Adapter 6ORB To6JIC	1
23	AFFAST194288	630038	Block Down Pressure (1PDCP25-PT-12S)	1
24	TO68010606	610078	Fitting Adapter 6ORB To 6JIC90°	1
25		600045-1A-ZN	FDM6R17-6FJXZ-6FJX90MZ-25	2
26	TO-2406-6-4	610002	Fitting Adapter 2406-04-06	1
27		600045-2A-ZN	FDM6R17-6FJXZ-6FJX90MZ-25.5	1
28	TO-6602-04-04-04	610026	Fitting Adapter JIC Swivel Run TeeTo-6602-04-04-04	1
29	TO-6506-4-4-S	610025	Fitting Adapter 6506-4-4	1
30	AF2141GXB3000	790052	Gauge Pressure 0-3000 PSI	1
31		600056-2-ZN	FDM4R17-6FJXZ-4FJX90MZ-50	1
32		600056-3-ZN	FDM4R17-6FJXZ-4FJX90MZ-60	2
33	TO-6400-04-08	610009	Fitting Adapter 8ORB To4JIC	2

833P Hydraulic System

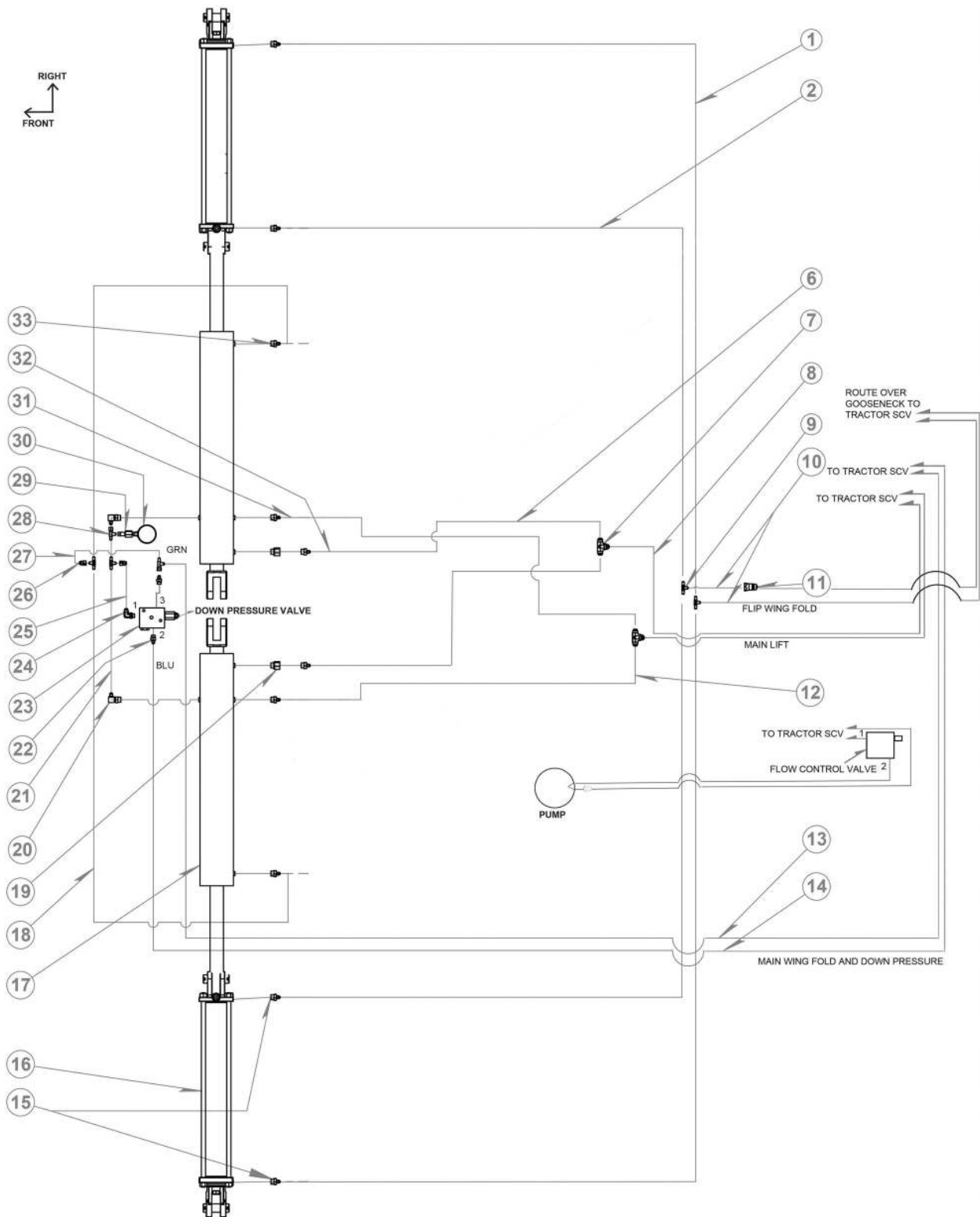



ILLUSTRATED PARTS LIST

833P Hydraulic System Parts List

Item	Part #	Description	Qty. 12 Row	Add For 16 Row Opt
1	600043-6	FDM4R17-4FJX-4FJX90M-153		2
2	600043-5	FDM4R17-4FJX-4FJX90M-126		2
6	600043-4	FDM6R17-6FJX90M-8FJX-90	2	
7	610004	FITTING ADAPTER TEE 8JIC	2	
8	600043-1	FDM8R17-8MBO-8FJX-156	2	
9	610003	FITTING ADAPTER JIC TEE TO-2603-04-04-04		2
10	600043-2	FDM4R17-8MBO-4FJX90M-306		2
11	520048	2-NV12-12SAE-M	4	2
12	600043-3	FDM6R17-6FJX90M-8FJX-102	2	
13	600043-18	FDM6R17-8MBO-6FJX-90M-293	1	
14	600043-13	FDM6R17-8MBO-6FJX-285	1	
15	610045	FITTING ADAPTER 8ORB TO 4JIC R0.045 (USED ON 620004)	4	
16	620004	CYLINDER 30TD24-150 3" X 24" STROKE	2	
NS	649208	KIT SEAL 3.0 BORE X 1.5 ROD		
17	620027	CYLINDER DUAL FUCTION 45WD22.5 X 1.81 WK	2	
NS	PMI0002	KIT SEAL 4.5 BORE X 2.0 ROD		
18	600043-17	FDM4R17-4FJX-4FJX-32	2	
19	610094	FITTING ADAPTER 8ORB M/F .047 ORIFICE	2	
20	610029	FITTING ADAPTER 8ORB TO 4JIC 90°	2	
21	600043-17	FDM4R17-4FJX-4FJX-32	2	
22	610010	FITTING ADAPTER 6ORB TO 6JIC	1	
23	630038	BLOCK DOWN PRESSURE (1PDCP25-PT-12S)	1	
24	610078	FITTING ADAPTER 6ORB TO 6JIC 90°	1	
25	600043-14	FDM6R17-6FJX-6FJX90M-9	1	
26	TO24060406	FITTING ADAPTER 2406-04-06	2	
27	600048-1-ZN	FDM6R17-6FJX-6FJX90M-6.5		
28	600043-17	FDM4R17-4FJX-4FJX-32	1	
29	610026	FITTING ADAPTER JIC SWIVEL RUN TEE TO-6602-04-04-04	1	
30	610025	FITTING ADAPTER 6506-4-4	1	
31	790052	GAUGE PRESSURE 0-3000 PSI	1	
32	600043-19	FDM4R17-6FJX-4FJX90M-45	2	
33	600043-8	FDM4R17-6FJX-4FJX90M-61	2	
34	600041-5	FDM4R17-4FJX-4FJX90M-56	1	

813P Hydraulic Schematic

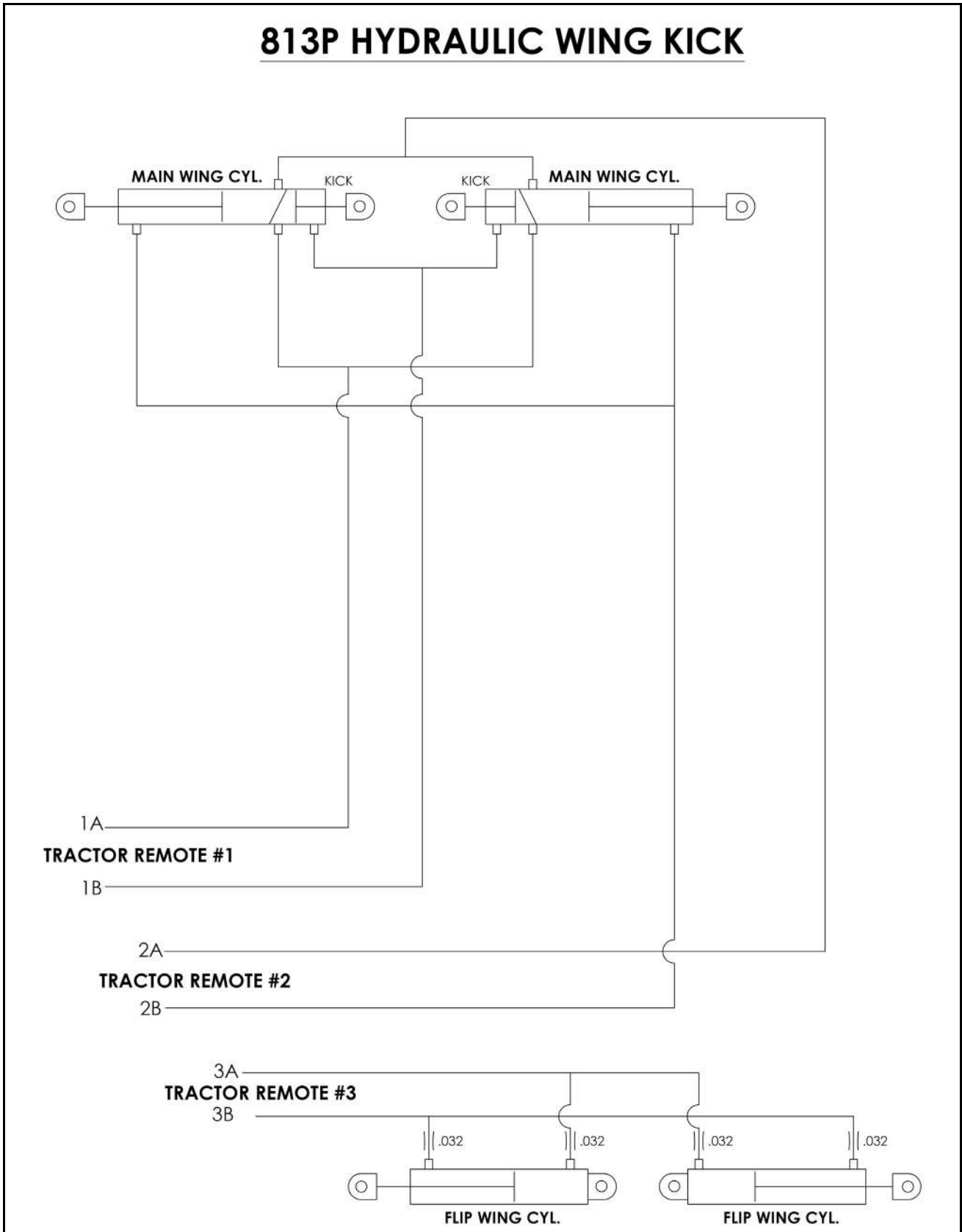



ILLUSTRATED PARTS LIST

813P Hydraulic Schematic Parts List

ITEM	PART NO.	QTY.	DESCRIPTION
1	620030	2	CYLINDER, MAIN WING (813P)
1	649080	1	Kit, Seal 5.0 Bore X 2.0 Rod
2	620057	2	CYLINDER, FLIP WING (813P)
2	MI649208	1	Kit, Seal 3.0 Bore X 1.5 Rod
3	520048	8	2-NV12-12SAE-M - HYDRAULIC TIP
4	600051-1-ZN	6	HOSE, HYDRAULIC, FDM4R17-8MBO-4FJX - Trailer to flip and main wings
5	600051-2-ZN	1	HOSE, HYDRAULIC, FDM4R17-4FJX-4FJX90M - Left Flip Ram
6	600051-3-ZN	1	HOSE, HYDRAULIC, FDM4R17-4FJX-4FJX90M - Left Flip Base
7	600051-4-ZN	1	HOSE, HYDRAULIC, FDM4R17-4FJX-4FJX90M - Right Flip Ram
8	600051-5-ZN	1	HOSE, HYDRAULIC, FDM4R17-4FJX-4FJX90M - Right Flip Base
9	600051-6-ZN	1	HOSE, HYDRAULIC, FDM4R17-4FJX-4FJX90M - Right Wing kick Ram
10	600051-7-ZN	1	HOSE, HYDRAULIC, FDM4R17-4FJX-4FJX90M - Right Wing kick Base
11	600051-8-ZN	1	HOSE, HYDRAULIC, FDM4R17-4FJX-4FJX90M - Left Wing kick Ram
12	600051-9-ZN	1	HOSE, HYDRAULIC, FDM4R17-4FJX-4FJX90M - Left Wing kick Base
13	600051-10-ZN	1	HOSE, HYDRAULIC, FDM4R17-4FJX-4FJX - Right Main Fold Base
14	600051-11-ZN	1	HOSE, HYDRAULIC, FDM4R17-4FJX-4FJX90M - Right Main Fold Ram
15	600051-12-ZN	1	HOSE, HYDRAULIC, FDM4R17-4FJX-4FJX - Left Main Fold Base
16	600051-13-ZN	1	HOSE, HYDRAULIC, FDM4R17-4FJX-4FJX90M - Left Main Fold Ram
17	600046-13-ZN	1	HOSE, HYDRAULIC, FDM8R17-8MBO-10MBO90
18	600046-14-ZN	1	HOSE, HYDRAULIC, FDM10R17-8MBO-10MBO90

833P Hydraulic Schematic

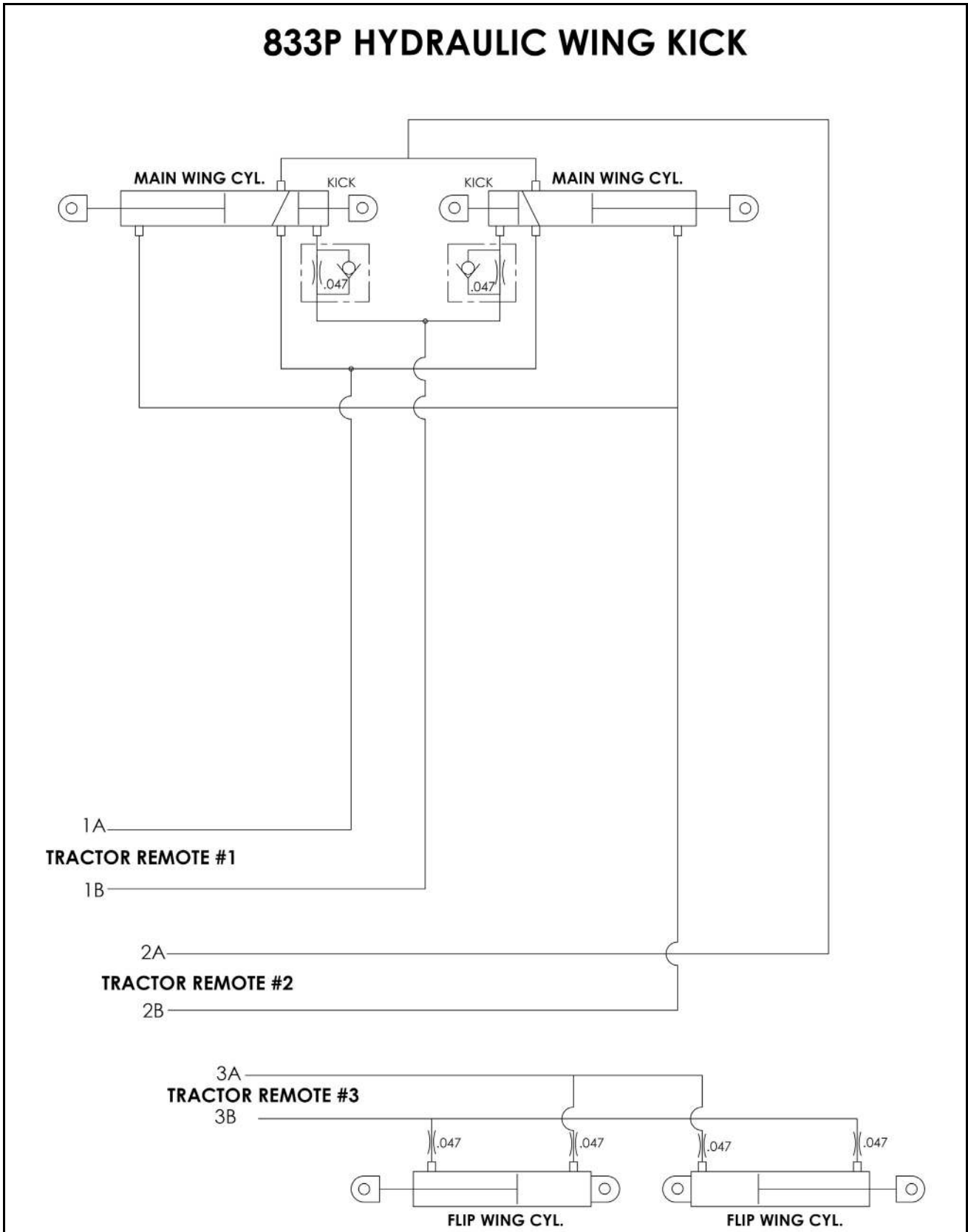



ILLUSTRATED PARTS LIST

833P Hydraulic Schematic Parts List

ITEM	PART NO.	QTY.	DESCRIPTION
1	620027	2	CYLINDER, MAIN WING (833P)
1	MP-PMI0002	1	Kit Seal 4.5 Bore X 2.0 Rod
2	620004	2	CYLINDER, FLIP WING (833P)
2	649208	1	KIT SEAL 3.0 BORE X 1.5 ROD
3	520048	8	2-NV12-12SAE-M ISO TIP
4		2	2406-4-6
5	600046-1A-ZN	2	HOSE, HYDRAULIC, FDM6R17-6FJXZ-8MBOZ-71
6	600046-2A-ZN	4	HOSE, HYDRAULIC, FDM4R17-4FJXZ-8MBOZ-71
7	600046-3-ZN	1	HOSE, HYDRAULIC, FDM4R17-4FJXZ-4FJX90MZ-145
8	600033-7-ZN	1	HOSE, HYDRAULIC, FDM4R17-4FJXZ-4FJX90MZ-118
9	600046-4-ZN	1	HOSE, HYDRAULIC, FDM4R17-4FJXZ-4FJX90MZ-159
10	600046-5-ZN	1	HOSE, HYDRAULIC, FDM4R17-4FJXZ-4FJX90MZ-132
11	600046-6-ZN	1	HOSE, HYDRAULIC, FDM4R17-4FJXZ-4FJX90MZ-36
12	600046-7-ZN	1	HOSE, HYDRAULIC, FDM4R17-4FJXZ-4FJX90MZ-40
13	FDM 0019-ZN	1	HOSE, HYDRAULIC, FDM4R17-4FJXZ-4FJX90MZ-21
14	600046-8-ZN	1	HOSE, HYDRAULIC, FDM4R17-4FJXZ-4FJX90MZ-26
15	600046-9-ZN	1	HOSE, HYDRAULIC, FDM4R17-4FJXZ-4FJXZ-41
16	600046-10-ZN	1	HOSE, HYDRAULIC, FDM4R17-4FJXZ-4FJX90MZ-66
17	600046-11-ZN	1	HOSE, HYDRAULIC, FDM4R17-4FJXZ-4FJXZ-27
18	600046-12-ZN	1	HOSE, HYDRAULIC, FDM4R17-4FJXZ-4FJX90MZ-51
19	600046-13-ZN	1	HOSE, HYDRAULIC, FDM8R17-8MBO-10MBO90-115
20	600046-14-ZN	1	HOSE, HYDRAULIC, FDM10R17-8MBO-10MBO90-115
21	600046-15-ZN	2	HOSE, HYDRAULIC, FDM4R17-4FJXZ-4FJX90MZ-20

Lighting

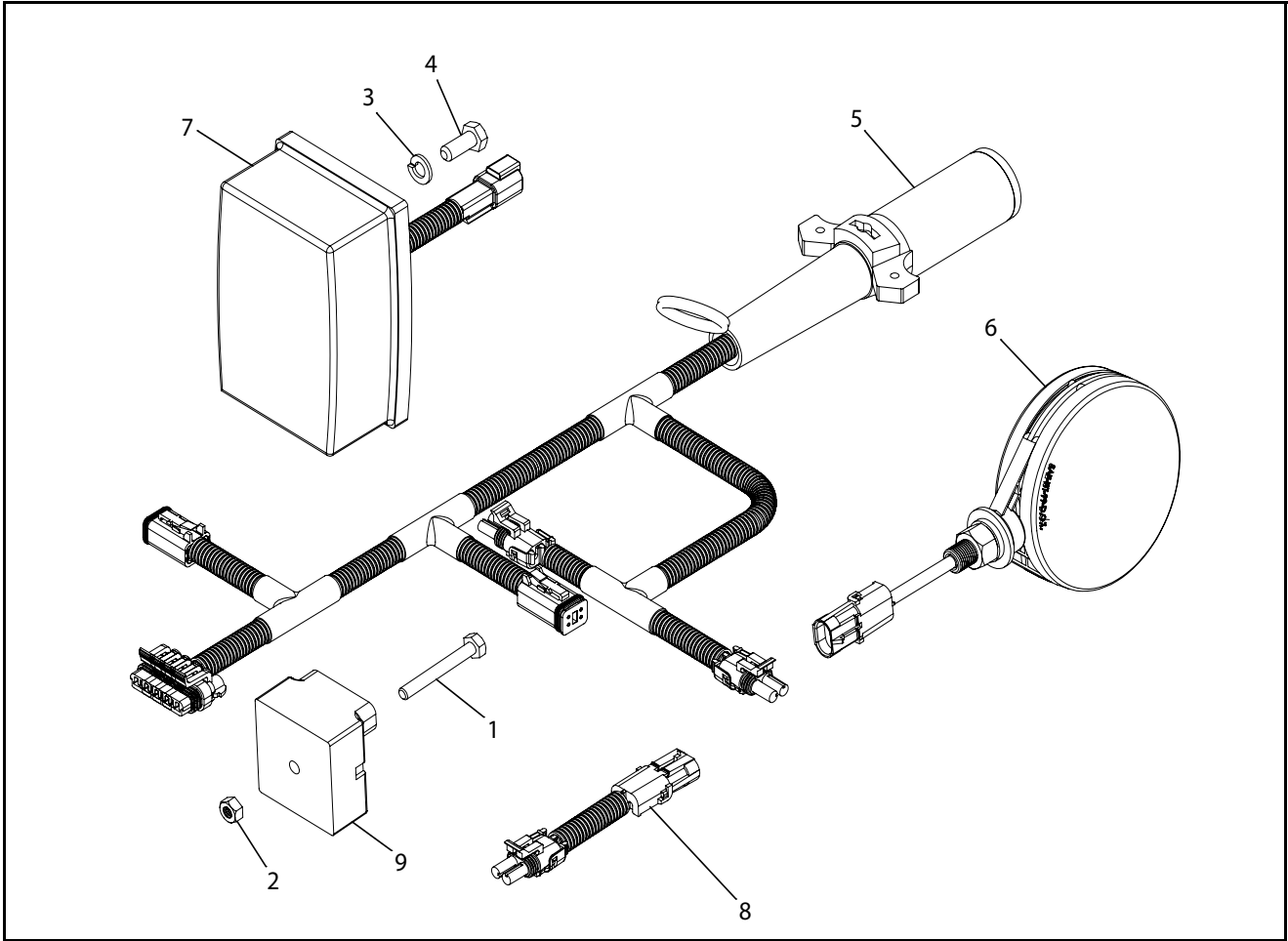



ILLUSTRATED PARTS LIST

Lighting Parts List

ITEM	PART NO.	QTY.	DESCRIPTION
1	104	1	BOLT, 1/4 X 2" GRADE 5 ZP
2	235	1	NUT, CENTERLOCK, 1/4" ZP
3	249	4	WASHER, LOCK, 5/16" ZP
4	590229	4	BOLT, 8 X 20 MM 8.8 ZP
5	740023	1	APPLICATOR LIGHT WIRING HARNESS
6	740024	2	AMBER WARNING LIGHT
7	740025	2	RED TAIL LIGHT
8	740029	2	EXTENSION
9	740031	1	LIGHT MODULE



NOTES



FAST GLOBAL SOLUTIONS

4130 Commerce Boulevard

Windom, MN 56101

1-800-772-9279 Toll Free

1-507-427-3861 Voice

1-507-427-3030 Fax

www.fastsprayers.com