



UT3P25 / 30 / 30BL / 40 / 45 / H40 / H45
UTILITY SPRAYER
OWNER'S MANUAL





Table of Contents

Section	Page
Table of Contents	iii
Warranty Registration	x
<i>Warranty Inspection Report</i>	<i>x</i>
Inspections	xii
<i>Pre-Delivery</i>	<i>xii</i>
<i>Delivery</i>	<i>xiii</i>
<i>After-Sale</i>	<i>xiv</i>
Owner Register	xv
Foreword to the Owner	xvi
INTRODUCTION	18
MAJOR COMPONENTS	19
SAFETY	22
<i>Safety Alert Symbols and Signal Words</i>	<i>22</i>
<i>General Safety</i>	<i>23</i>
Prepare for Emergencies	<i>23</i>
Wear Protective Clothing	<i>23</i>
Protect Against Noise	<i>23</i>
Practice Safe Maintenance	<i>23</i>
Support Raised Equipment	<i>24</i>
Avoid Heating Near Pressurized Fluid Lines	<i>24</i>
Avoid High-Pressure Fluids	<i>24</i>
Inspect Lift Circuit Hoses	<i>25</i>
Store Attachments Safely	<i>25</i>
Electrical	<i>25</i>
Service Tires Safely	<i>25</i>
Dispose of Waste Properly	<i>26</i>
Handle Agricultural Chemicals Safely	<i>26</i>
Reduce risk of exposure and injury:	<i>26</i>
Handle Chemical Products Safely	<i>27</i>
Operate Hydraulics Safely	<i>27</i>
Use Safety Lights and Devices	<i>28</i>
Keep Riders Off Machine	<i>28</i>
Observe Maximum Transport Speed	<i>28</i>
EC Compliance Notification	<i>29</i>
Use a Signal Person	<i>29</i>



Use a Safety Chain	29
Tow Loads Safely	29
Avoid Overhead Power Lines	30
Prepare for Transport	30
Transport Safely	31
<i>Replace Safety Signs</i>	31
General	32
Lights and Reflectors	33
<i>Sign-Off Form</i>	34
SPECIFICATIONS	35
<i>Tractor Power, Size Recommendation</i>	35
<i>Hydraulic System Requirements</i>	35
<i>Sprayer Weights</i>	35
<i>Sprayer Maximum Speeds</i>	36
<i>Machine Dimensions & Specifications</i>	36
<i>Sprayer Standard Features</i>	36
<i>Sprayer System Options</i>	37
HYDRAULIC FLOW	38
<i>Regulating Hydraulic Flow to the Pump</i>	38
Load Sensing Closed Center System (LS Closed)	38
Pressure Compensating Closed-Center System (PC Closed)	38
Open Center System (Open)	39
<i>Tractor SCV Functions</i>	40
PREPARING THE MACHINE	42
<i>Use the Tractor Operator's Manual</i>	42
<i>Assembly</i>	42
Drain and Rinse Tank	42
Drain Filters	42
Drain Tank	42
Connect the PTO Pump	43
Set the (Optional) Hydraulic Motor Driven Chemical Pump	44
Unpack the Spray Wand	44
Install 3-Point Hitch Bushings and Spacers	45
<i>Pre-Operation Checklist</i>	46
ATTACHING and DETACHING	47
<i>Attach the Machine Safely</i>	47
<i>Attach the Machine to the Tractor</i>	47
<i>Make Proper Hose Connections</i>	49



Detach Machine the Machine Safely 51

Detach the Machine from the Tractor 51

TRANSPORTING **54**

Following Safe Transport Procedures 54

Caution for All Machines 54

Transporting the Machine 55

 Notes and Checks 55

 Using Warning Lights 55

 Keep Riders Off the Machine 55

Un/Folding the Machine: Manual 56

 Unfold the Boom: Manual 56

 Fold the Boom: Manual 58

Un/Folding the Machine: Hydraulic 60

 Unfold the Boom: Hydraulic 60

 Fold the Boom: Hydraulic 61

FIELD OPERATION **62**

Adjust Ground Speed 63

 Broadcast Spraying 63

FILLING THE TANKS **64**

Filling the Product Tank 64

Filling the Fresh Water Rinse Tank 66

Use the Rinse Tank 66

Filling the Foam Tank 66

CONTROLS **67**

Agitation Pump 67

 Optional Agitation Pump Valve Bar 67

Section Valves 68

Section Valve Controller 69

BOOM HEIGHT ADJUSTMENT **70**

Adjust the Height of the Boom 70

 Hitch Adjustment 70

 Boom Height Adjustment for Manual Models Only 71

Leveling the Booms 71

Breakaway Clutch Tension 72

SPRAYER CALIBRATION **73**

Engine RPM 73



<i>Automatic Controller Calibration (if equipped)</i>	73
<i>Ground Speed Calculation</i>	73
<i>Travel Timetable</i>	74
<i>Nozzle Calibration</i>	75
<i>Boom Spray Nozzles</i>	75
<i>Boomless Spray Nozzles</i>	75
SPRAY WAND	76
FOAM MARKER	79
<i>Compressor Check</i>	79
<i>Mixing Foam</i>	79
<i>Filling the Foam Tank</i>	80
<i>Flow Control Valve & Tubing Connections</i>	80
LUBRICATION & MAINTENANCE	81
<i>Lubricating and Maintaining the Machine Safely</i>	81
<i>Lubricant Storage</i>	81
<i>Grease</i>	82
<i>Greases for Air Temperature Ranges</i>	82
<i>Alternative and Synthetic Lubricants</i>	82
<i>Frame Lubrication</i>	82
<i>Pump Maintenance and Service</i>	83
<i>Filter</i>	83
<i>Boom Maintenance and Service</i>	85
<i>Nozzles</i>	85
<i>Single Spray Nozzle</i>	85
<i>Wing Bumpers</i>	85
<i>Boom Clamps</i>	85
<i>Gas Shock Replacement</i>	86
<i>Tank Maintenance and Service</i>	87
<i>Tank Drain Procedure</i>	87
<i>Tank Straps</i>	87
<i>Spray Wand Maintenance</i>	87
<i>Clean the Nozzle</i>	87
<i>Foam Row Marker Maintenance</i>	88
<i>Foamheads and Screen/Strainer</i>	88
<i>Tank and Hoses</i>	88
<i>Cleaning</i>	89
<i>Daily</i>	89
<i>To Remove Salt and Amines Formations</i>	89
<i>To Remove Esters of 2, 4-D and MCPA Formations</i>	89



SERVICE	90
<i>Practice Safe Maintenance.....</i>	<i>90</i>
<i>Work in a Clean Area.....</i>	<i>90</i>
<i>Service Machines Safely</i>	<i>90</i>
<i>Support the Machine Properly</i>	<i>91</i>
<i>Avoid High-Pressure Fluids</i>	<i>91</i>
<i>Preventing Hydraulic System Contamination</i>	<i>91</i>
<i>Replace Hydraulic Hoses</i>	<i>92</i>
<i>Tightening Hardware</i>	<i>92</i>
<i>Pressure Gauge Replacement.....</i>	<i>92</i>
<i>Taillight Replacement</i>	<i>93</i>
<i>Spray Wand Service</i>	<i>94</i>
Hose Replacement	94
Hose-Tank Connection Replacement	95
PREPARING FOR STORAGE	96
<i>Winterization.....</i>	<i>96</i>
For the Foam Row Marker	96
<i>Removing from Storage.....</i>	<i>97</i>
TROUBLESHOOTING.....	98
<i>General.....</i>	<i>98</i>
<i>Controller.....</i>	<i>98</i>
<i>Foam Maker</i>	<i>99</i>
TIGHTENING HARDWARE	100
<i>Metric Bolt and Screw Torque Values</i>	<i>100</i>
<i>Unified Inch Bolt and Screw Torque Values</i>	<i>101</i>
<i>Face Seal Fittings Assembly & Installation - All Pressure Applications</i>	<i>102</i>
Face Seal O-Ring to Stud End Installation	102
Face Seal Adjustable Stud End O-Ring Installation	102
Face Seal Straight Stud End O-Ring Installation	102
Fitting Installation	102
Assembly Torque	102
<i>SAE Face Seal and O-Ring Stud End Fitting Torque Chart</i>	<i>103</i>





Limited Warranty

Fast Ag Solutions warrants to the buyer that the new machinery is free from defects in material and workmanship.

This warranty is only effective as to any new machinery which has not been altered, changed, repaired or treated since its delivery to the buyer, other than by Fast Ag Solutions or its authorized dealers or employees, and does not apply to accessories, attachments, tools or parts, sold or operated with the new machinery, if they have not been manufactured by Fast Ag Solutions.

Fast Ag Solutions shall only be liable for defects in the materials or workmanship attributable to faulty material or bad workmanship that can be proved by the buyer, and specifically excludes liability for repairs arising as a result of normal wear and tear of the new machinery or in any other manner whatsoever, and without limiting the generality of the foregoing, excludes application or installation of parts not completed in accordance with this Operator's Manual, specifications, or printed instructions.

Written notice shall be given by registered mail, to the Manufacturer within seven (7) days after the defect shall have become apparent or the repairs shall have become necessary, addressed as follows:

Fast Ag Solutions
4130 Commerce Boulevard
Windom, MN 56101

This warranty shall expire one (1) year after the date of delivery of the new machinery.

If these conditions are fulfilled, Fast Ag Solutions shall at its own cost and at its own option either repair or replace any defective parts provided that the buyer shall be responsible for all expenses incurred as a result of repairs, labor, parts, transportation or any other work, unless Fast Ag Solutions has authorized such expenses in advance.

The warranty shall not extend to any repairs, changes, alterations, or replacements made to the new equipment other than by Fast Ag Solutions or its authorized dealers or employees.

This warranty extends only to the original owner of the new equipment.

Rubber parts (including tires, hoses, grommets) are not warranted.

This warranty is limited to the terms stated herein and is in lieu of any other warranties whether express or implied, and without limiting the generality of the foregoing, excluded all warranties, express or implied or conditions whether statutory or otherwise as to quality and fitness for any purpose of the new equipment. The Manufacturer disclaims all liability for incidental or consequential damages.

This Utility Sprayer is subject to design changes and Fast Ag Solutions shall not be required to retrofit or exchange items on previously sold units except at its own option.

Warranty void if not registered.



FAST UTILITY SPRAYER

Warranty Registration

This form must be filled out by the dealer and signed by both the dealer and the customer at the time of delivery.

Customer Name					
Address					
City		State		Zip	
Phone					

Dealer Name					
Address					
City		State		Zip	

Sprayer Model					
Serial Number					
Delivery Date					

Warranty Inspection Report

DEALER INSPECTION REPORT

- All Fasteners Tight
- Wheel Bolts Torqued
- Hydraulic Hoses and Fittings Free and Tight
- Fertilizer Hoses and Fittings Free and Tight
- Wheel Drive Turns Freely
- Lubricate Machine
- Check Tire Pressure
- Frame and Wings Level
- Monitors and Controllers Function
- Wiring Harness Connected

SAFETY

- Safety Chain Installed
- All Guards Installed
- All Safety Signs Installed
- Reflectors, SMV, and Lights Clean
- Review Operating and Safety Instructions

I have thoroughly instructed the buyer on the above-described equipment which review included the Operator's Manual content, equipment care, adjustments, safe operation, and applicable warranty policy.

Date _____
Dealer's Rep. Signature _____

The above equipment and Operator's Manual have been received by me, and I have been thoroughly instructed as to care, adjustments, safe operation, and applicable warranty policy.

Date _____
Owner's Signature _____

White - FAST
Yellow - Dealer
Pink - Customer



FAST UT3P25 / 30 / 30BL / 40 / 45 / H40 / H45 Series Sprayer

SPRAYER SERIAL NUMBER _____

DATE PURCHASED _____ / _____ / _____

TANK SIZE (CIRCLE ONE) **250 Gal.** **300 Gal.**

BOOM WIDTH (CIRCLE ONE) **25' / 30' / 40' / 45'**

BOOM FOLDING (CIRCLE ONE)

MANUAL HYDRAULIC BOOMLESS

PUMP MANUFACTURER (CIRCLE ONE)

ACE FMC-75-HYD-204

ACE FMC-150-HYD-206

HYPRO 6500C

Inspections

Pre-Delivery

After the machine has been completely assembled, inspect it to be sure it is in good running order before delivering it to the customer. Ensure each item is found satisfactory or proper adjustment to the item(s) is made.

The following checklist is a reminder of points to inspect. It is neither an exclusive nor an exhaustive list of points to inspect. See the [Warranty Inspection Report](#) for a formal list.

- **SMV** emblem is installed, protective **shipping tape** is removed from reflectors, and **lights** are installed.
- All **grease fittings** are lubricated (see [LUBRICATION and MAINTENANCE](#) section in this Manual.)
- Inspect to be sure all **nuts** are tightened to proper torque and all **cotter pins** are spread.
- The **tires** are properly inflated (see [SPECIFICATIONS](#)).
- **Wheel bolts** are tightened to their specified torque(s).
- Fertilizer **row units** are properly adjusted.
- Warning **lights** are properly installed and operational.
- All customer-ordered **attachments** are installed or are available for delivery.
- Any parts scratched in shipment are touched up with **paint**.
- All **shipping decals** are removed.
- **Transport pins** are inserted in the transport holes.

This machine has been thoroughly checked and to the best of my knowledge is ready for delivery to the customer.

Signed: _____

Date: _____



Delivery

The following checklist is a reminder of information which should be conveyed directly to the customer at the time the machine is delivered.

Check off each item as it is fully relayed to the customer.

- Tell the customer to use proper tools.
- Explain to the customer that the life expectancy of this or any other machine depends on regular lubrication as directed in Operator's Manual.
- Make the customer aware of all safety precautions that must be followed while using this machine.
- When the machine is transported on a road or highway at night or during the day, accessory lights and devices should be used for adequate warning to Operators of other vehicles. For this matter, tell the customer to check local governmental regulations.
- Give the Operator's Manual to the customer and explain all operating adjustments.

To the best of my knowledge, this machine has been delivered ready for field use, and the customer has been fully informed as to its proper care and operation.

Signed: _____

Date: _____

After-Sale

The following is a suggested list of items to be checked at a dealer-customer mutually agreeable time during the first operating season.

- Check with the customer as to performance of machine. Make certain proper operating adjustments are understood.
- If possible, operate the machine to see that it is functioning properly.
- Acquaint the customer with any special attachment which will help do a better job.
- Go over the entire machine for loose or missing hardware.
- Check for broken or damaged parts.
- Ask the customer if recommended periodic lubrication has been performed.
- Review the Operator's Manual with the customer and stress the importance of proper lubrication and safety precautions.

Signed: _____

Date: _____



Owner Register

Model Number	P.I.N. Number
--------------	---------------

Name		
Address		
County	State	Date Purchased

Name		
Address		
County	State	Date Purchased

Name		
Address		
County	State	Date Purchased

Name		
Address		
County	State	Date Purchased

Foreword to the Owner



READ THIS MANUAL carefully to learn how to operate and service your machine correctly. Failure to do so could result in personal injury or equipment damage. This Manual and safety signs on your machine may also be available in other languages.

THIS MANUAL SHOULD BE CONSIDERED a permanent part of your machine and should remain with the machine when you sell it.

MEASUREMENTS in this Manual are given in both metric and customary U.S. unit equivalents. Use only correct replacement parts and fasteners. Metric and inch fasteners may require a specific metric or inch wrench.

RIGHT-HAND AND LEFT-HAND sides are determined by facing in direction that the implement will travel when going forward.

WRITE PRODUCT IDENTIFICATION NUMBERS (P.I.N.) in the [Specification](#) section and in the [Owner Register](#). Accurately record all numbers to help in tracing your machine should it be stolen. Your dealer also needs these numbers when you order parts. File identification numbers in a safe place off-machine.

BEFORE DELIVERING THIS MACHINE, your dealer performed a pre-delivery inspection.

THIS UTILITY SPRAYER IS DESIGNED SOLELY for use in customary agricultural or similar operations for the purpose of applying chemical to row crops (“Intended Use”). Use in any other way is considered as contrary to the Intended Use. The manufacturer accepts no liability for



damage or injury resulting from this misuse, and these risks must be borne solely by the user. Compliance with and strict adherence to the conditions of operation, service, and repair as specified by the manufacturer also constitute essential elements for the Intended Use.

THIS UTILITY SPRAYER SHOULD BE OPERATED, serviced, and repaired only by persons familiar with all its particular characteristics and acquainted with the relevant safety rules (Accident Prevention). The Accident Prevention regulations, all other generally recognized regulations on safety and occupational medicine and the road traffic regulations must be observed at all times.

Any arbitrary modifications carried out on this Utility Sprayer will relieve the manufacturer of all liability for any resulting damage or injury.

THIS DOCUMENT outlines the specific design and performance requirements for the use of a Fast Ag Solutions Utility Sprayer assembly. The word “must” in this document indicates a mandatory requirement. The use of “should” indicates a recommendation of that which is advised but not required.

WARRANTY is provided as part of Fast Ag Solutions' support program for customers who operate and maintain their equipment as described in this Manual. The warranty is explained on the warranty certificate which you should have received from your dealer.

This warranty provides you with assurance that Fast Ag Solutions will back its products where defects appear within the warranty period. In some circumstances, Fast Ag Solutions also provides field improvements, often without charge to the customer, even if the product is out of warranty. Should equipment be abused or modified to change its performance beyond original factory specifications, the warranty will become void and field improvements may be denied.

TIRE MANUFACTURER'S warranty applicable to your machine may not apply outside U.S.

If you are not the original owner of this machine, it is in your interest to contact your local Fast Ag Solutions dealer to inform them of this unit's serial number. This will help Fast Ag Solutions notify you of any issues or product improvements.

INTRODUCTION



Read this Manual carefully before operating your FAST equipment. The information presented will prepare you to safely operate and service your machine.

All Operators are required to read this Manual carefully and be acquainted with all the operating and adjustment procedures before attempting to operate. Failure to follow the information in this Manual and on decals may result in personal injury or equipment damage.

This Manual should be considered a permanent part of this equipment and should remain with the equipment when you sell it. Replacement manuals can be obtained from your Fast Ag Solutions dealer.

This equipment has been engineered and manufactured to provide dependable and satisfactory use. Like all mechanical products, it will require cleaning and upkeep. Inspect your equipment before putting it into service. Your authorized Fast Ag Solutions dealer has trained mechanics, genuine FAST service parts, and the necessary tools and equipment when service is needed. Use only genuine FAST parts for service or repairs. Substitute parts will void the warranty and may not meet standards for safe and satisfactory operation.

Warranty is provided as part of Fast Ag Solutions' support program for customers who operate and maintain their equipment as described in this Manual. The warranty is explained on the warranty certificate you should have received from your dealer. This warranty provides you with the assurance that Fast Ag Solutions will back its products where defects appear within the warranty period. Should the equipment be abused or modified to change its performance beyond the original factory specifications, the warranty will become void.

These instructions have been compiled from field experience and engineering data. Some information may be general in nature due to unknown and varying operating conditions. However, through experience and these instructions, you should be able to develop procedures suitable to your particular situation.

.....

The illustrations and data used in this Manual were current at the time of printing. However, due to possible in-line production changes, your machine may vary slightly in detail. We reserve the right to redesign and change the machines as necessary without notification.

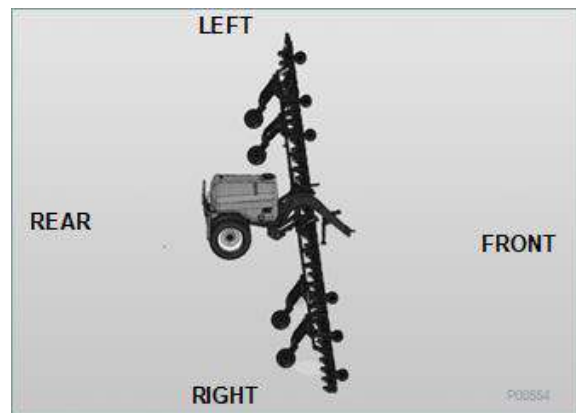
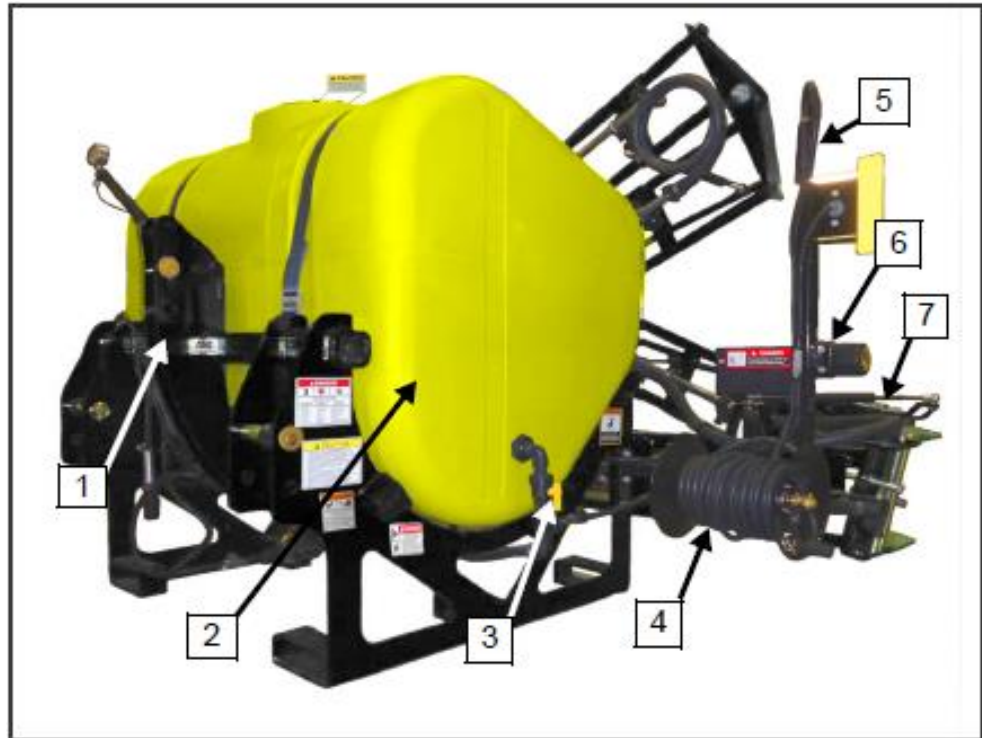

Figure 1: Orientation is viewed from behind the machine

MAJOR COMPONENTS

1. 3-Point Hitch
2. Tank
3. Tank Agitation Valve
4. Hose Reel
5. Spray Wand
6. Manual Holder
7. Breakaway Wing Clutch



8. Taillights
9. Nozzle
10. Flip Wing Section
11. Main Wing Section
12. Stainless Steel Wet Boom
13. Center Boom Section
14. Stand / Forklift Tine-ways

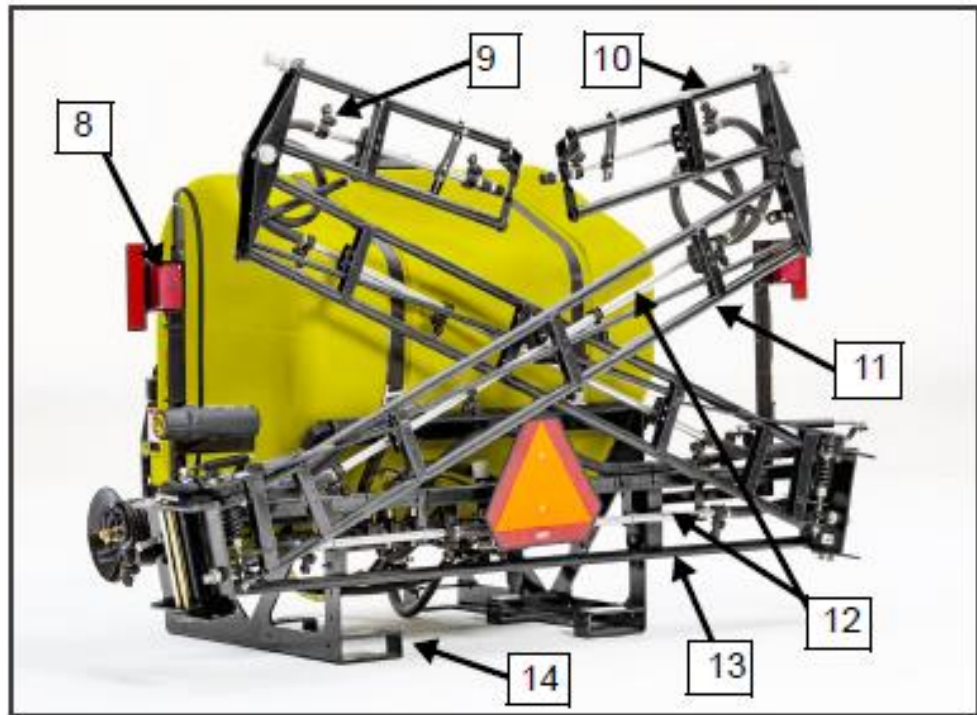

- 15. Nozzle
- 16. Solution Lines
- 17. Taillights
- 18. Stand / Forklift Tine-ways
- 19. Section Control Valves
- 20. Motorized Control Valve
- 21. Relief Valve (PTO Pump models only)
- 22. PTO Pump (PTO Pump models only)
- 23. Hydraulic Motor Driven Chemical Pump (hydraulic models only)
- 24. Tank Valve

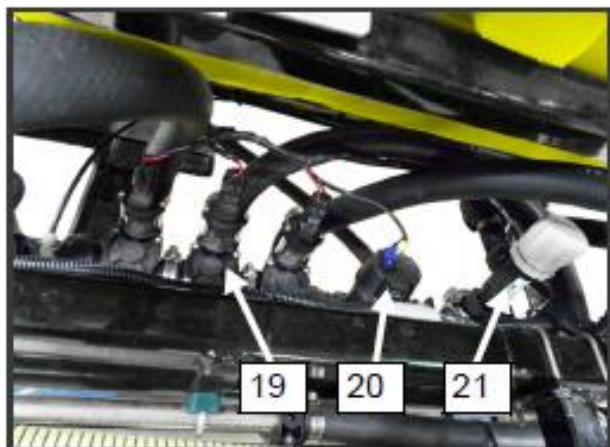
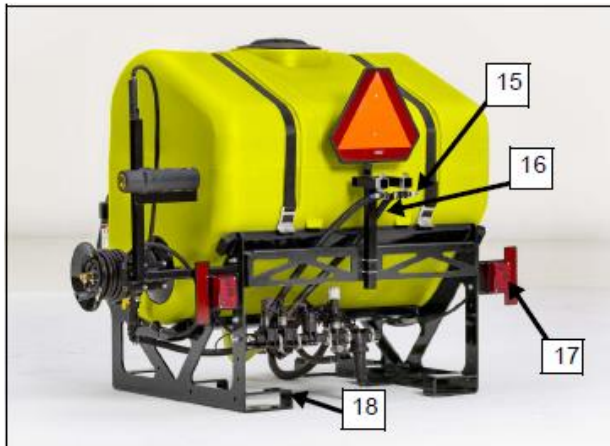
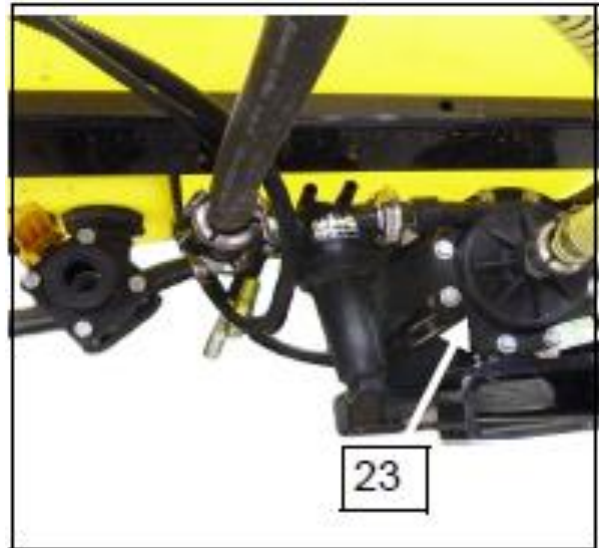

- 25. Pressure Gauge
- 26. Cord / PTO Storage
- 27. Valve Control Box (installed in tractor cab)

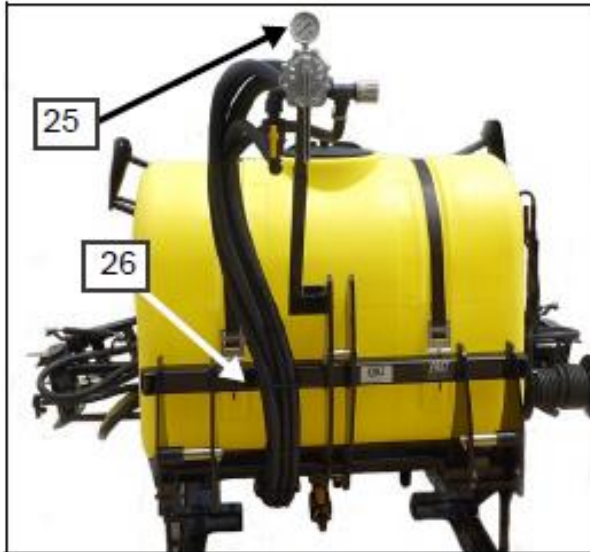

SAFETY

The most important safety device on this equipment is a safe Operator. It is the Operator's responsibility to read and understand and follow all safety and operating instructions in this Manual.

As the Operator, you are responsible for the safe operation and maintenance of this equipment. You must ensure that you and anyone else who is going to operate, maintain or work around the machine is familiar with the operating and maintenance procedures and related safety information contained in this Manual.

You are the key to safety. Good safety practices protect you and the people around you. Be certain that everyone operating this equipment is familiar with the recommended operating and maintenance procedures and follows all safety precautions. Do not risk injury or death by ignoring good safety practices.

Safety Alert Symbols and Signal Words



This is a Safety Alert Symbol. When you see this symbol on your machine or in this Manual, be alert to the potential for personal injury.

Follow recommended precautions and safe operating practices.

Understand Signal Words

Throughout this Manual, the terms *CAUTION*, *WARNING*, and *DANGER* are used along with the Safety Alert Symbol to indicate the degree of personal safety hazard. The term *IMPORTANT* is used to indicate that failure to observe the hazard can cause damage to the equipment.



DANGER identifies the most serious hazards. DANGER or WARNING safety signs are located near specific hazards. General precautions are listed on CAUTION safety signs. CAUTION also calls attention to safety messages in this Manual.

Follow Safety Instructions

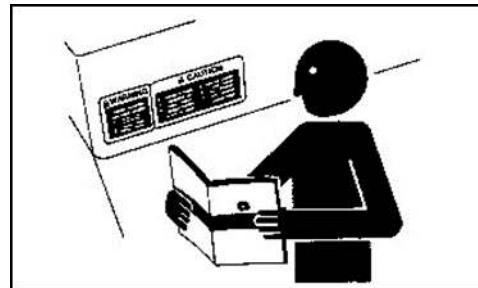

Carefully read all safety messages in this Manual and on your machine's safety signs. Keep safety signs in good condition.

Replace missing or damaged safety signs. Be sure new equipment components and repair parts include the current safety signs. Replacement safety signs are available from your Fast Ag Solutions dealer. There can be additional safety information contained on parts and components sourced from suppliers that is not reproduced in this Operator's Manual.

Learn how to operate the machine and how to use controls properly. Do not let anyone operate without instruction.

Keep your machine in proper working condition. Unauthorized modifications to the machine may impair the function and/or safety and affect machine life.

If you do not understand any part of this Manual and need assistance, contact your Fast Ag Solutions dealer.

General Safety

Prepare for Emergencies

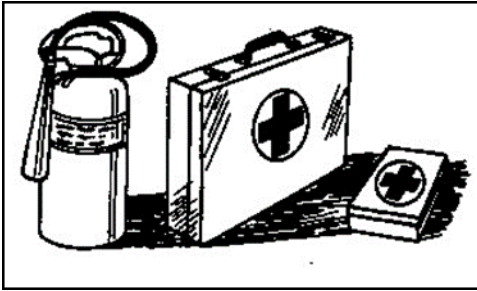

Be prepared if a fire starts.

Keep a first aid kit and fire extinguisher handy.

Keep emergency numbers for the poison control center, doctors, ambulance service, hospital, and fire department near your telephone.

Wear Protective Clothing

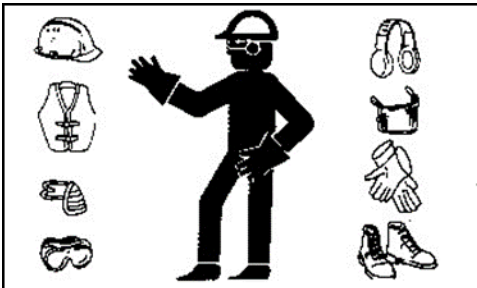

Wear close-fitting clothing and safety equipment appropriate to the job.

Operating equipment safely requires the full attention of the Operator. Do not wear radio or music headphones while operating the machine.

Protect Against Noise



Prolonged exposure to loud noise can cause impairment or loss of hearing.

Wear a suitable hearing protective device such as earmuffs or earplugs to protect against objectionable or uncomfortable loud noises.

Practice Safe Maintenance



Understand service procedures before doing work. Keep the area clean and dry.

Never lubricate, service, or adjust the machine while it is moving. Keep hands, feet, and clothing away from power-driven parts. Disengage all power and operate controls to relieve pressure. Lower equipment to the ground. Stop the engine. Remove the key. Allow machine to cool. Securely support any

machine elements that must be raised for service work.

Keep all parts in good condition and properly installed. Fix any damage immediately. Replace worn or broken parts. Remove any buildup of grease, oil, or debris.

On self-propelled equipment, disconnect the battery ground cable (-) before making any adjustments on electrical systems or welding on the machine.

On towed implements, disconnect wiring harnesses from tractor before servicing electrical system components or welding on the machine.

Support Raised Equipment



Always use a safety support when working on, under, or around the machine. Transport/Service locks can be used for this purpose.

Shut off the tractor's engine and remove the key when working on the machine.

If air has been allowed to enter hydraulic hoses or cylinders, bleed the hydraulic system before use. If there is a failure in the hydraulic system, unsupported or raised equipment could suddenly lower, causing serious personal injury or death.

If support is not available, completely lower wings and frame, relieve hydraulic pressure and disconnect hoses from tractor.

Avoid Heating Near Pressurized Fluid Lines



Flammable spray can be generated by heating near pressurized fluid lines, resulting in severe burns to yourself and bystanders. Do not heat by welding, soldering, or using a torch near pressurized fluid lines or other flammable materials. Pressurized lines can accidentally burst when heat goes beyond the immediate flame area.

Avoid High-Pressure Fluids



Inspect hydraulic hoses periodically – at least once per year – for leakage, kinking, cuts, cracks, abrasion, blisters, corrosion, exposed wire braid, or any other signs of wear or damage.

Replace worn or damaged hose assemblies immediately with Fast Ag Solutions approved replacement parts.

Escaping fluid under pressure can penetrate the skin causing serious injury.

Avoid the hazard by relieving pressure before disconnecting hydraulic or other lines. Tighten all connections before applying pressure.

Search for leaks with a piece of cardboard. Protect hands and body from high-pressure fluids.

If an accident occurs, see a doctor immediately. Any fluid injected into the skin must be surgically removed within a few hours or gangrene may result. Doctors unfamiliar with this type of injury should reference a knowledgeable medical source.

Inspect Lift Circuit Hoses



Avoid serious injury or death while working under a raised implement. Hydraulic hoses between the lift cylinders and hydraulic lock-up valves should be inspected frequently for leakage, kinking, cuts, cracks, abrasion, blisters, corrosion, exposed wire braid, or any other signs of wear or damage. Worn or damaged hose assemblies can fail during use and should be replaced immediately. See your Fast Ag Solutions dealer for replacement hoses.

Store Attachments Safely

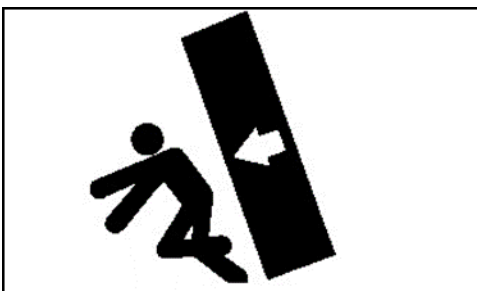

Stored attachments such as dual wheels can fall and cause serious injury or death. Securely store attachments and implements

to prevent falling. Keep playing children and bystanders away from storage area.

Electrical



Check all electrical wiring and connections for damage. Keep the battery terminals clean and tight. Repair or replace any damaged part or wires that are loose or frayed.

Service Tires Safely

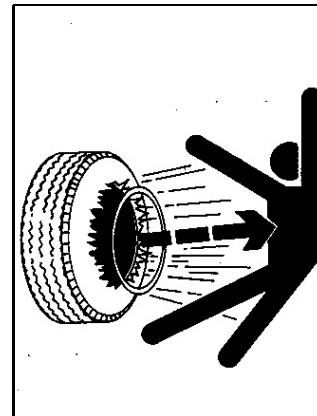

CAUTION: Explosive separation of a tire and rim parts can cause serious injury or death.

Do not attempt to mount a tire unless you have the proper equipment and experience to perform the job.

Always maintain the correct tire pressure. Do not inflate the tires above the recommended pressure. Never weld or heat a wheel and tire assembly. The heat can cause an increase in air pressure resulting in a tire explosion. Welding can structurally weaken or deform the wheel.

When inflating tires, use a clip-on chuck and extension hose long enough to allow you to stand to one side and NOT in front of or over

the tire assembly. Use a safety cage if available.

Check wheels for low pressure, cuts, bubbles, damaged rims, or missing lug bolts and nuts. Replace as necessary.

Dispose of Waste Properly

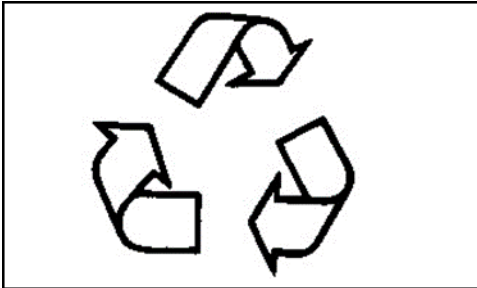

Improperly disposing of waste can threaten the environment and ecosystem. Potentially harmful waste used with equipment includes such items as oil, fuel, coolant, brake fluid, filters, and batteries.

Use leakproof containers when draining fluids. Do not use food or beverage containers that may mislead someone into drinking from them.

Do not pour waste onto the ground, down a drain, or into any water source.

Air conditioning refrigerants escaping into the air can damage the Earth's atmosphere. Government regulations may require a certified air conditioning service center to recover and recycle used air conditioning refrigerants.

Handle Agricultural Chemicals Safely

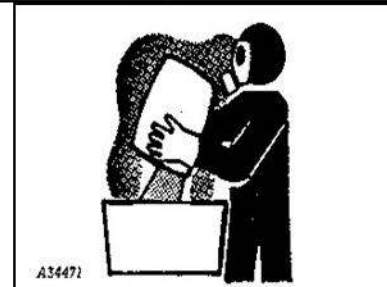
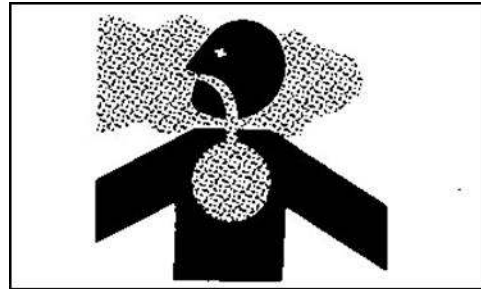

Chemicals used in agricultural applications such as fungicides, herbicides, insecticides, pesticides, rodenticides, and fertilizers can be harmful to your health or the environment if not used carefully.

Always follow all label directions for effective, safe, and legal use of agricultural chemicals.

Reduce risk of exposure and injury:

Wear appropriate personal protective equipment as recommended by the manufacturer. In the absence of manufacturer's instructions, follow these general guidelines:

Chemicals labeled 'Danger' (Most toxic) generally require use of goggles, respirator, gloves, and skin protection.

Chemicals labeled 'Warning' (Less toxic) generally require use of goggles, gloves, and skin protection.

Chemicals labeled 'Caution' (Least toxic) generally require the use of gloves and skin protection.

Avoid inhaling vapor, aerosol, or dust.

Always have soap, water, and a towel available when working with chemicals. If a chemical contacts skin, hands, or face, wash

immediately with soap and water. If chemical gets into eyes, flush immediately with water.

Wash hands and face after using chemicals and before eating, drinking, smoking, or urination.

Do not smoke or eat while applying chemicals.

After handling chemicals, always bathe or shower and change clothes. Wash clothing before wearing it again.

Seek medical attention immediately if illness occurs during or shortly after use of chemicals.

Keep chemicals in original containers. Do not transfer chemicals to unmarked containers or to containers used for food or drink.

Store chemicals in a secure, locked area away from human or livestock food. Keep children away.

Always dispose of containers properly. Triple rinse empty containers and puncture or crush containers and dispose of properly.

Handle Chemical Products Safely



Direct exposure to hazardous chemicals can cause serious injury. Potentially hazardous chemicals used with FAST equipment include such items as lubricants, coolants, paints, and adhesives.

A Material Safety Data Sheet (M/SDS) provides specific details on chemical products: physical and health hazards, safety procedures, and emergency response techniques.

Check the M/SDS before you start any job using a hazardous chemical. That way you will know exactly what the risks are and how to do the job safely. Then follow the procedures with the recommended equipment.

Operate Hydraulics Safely



Before operating, make sure air has been bled from wing-fold hydraulic system.

Be sure the area around the machine is clear before raising or lowering the machine's frame or wings.

Do not operate with wings folded.

Do not operate close to the edge of a ditch, creek, gully, or steep embankment. Avoid holes, ditches, and obstructions which may cause the tractor, machine, or towed equipment to roll over, especially on hillsides.

Avoid sharp turns on hillsides.

Slow down when turning, traveling over rough ground, or when turning on inclines.

Always shut off tractor and shift to PARK or set brakes when leaving tractor. Remove key when leaving tractor unattended.

Always have the tractor stop on level ground when raising or lowering wings. Operate the machine from tractor seat only. If chemicals are used, follow the manufacturer's recommendations for handling and storage.

Tow the machine behind a properly equipped tractor only.

Use Safety Lights and Devices

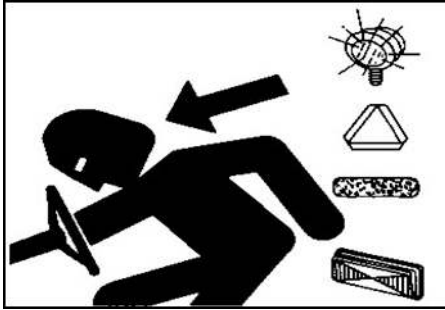

Prevent collisions between other road users, slow moving tractors with attachments or towed equipment, and self-propelled machines on public roads. Frequently check for traffic from the rear, especially in turns, and use turn signal lights.

Use headlights, flashing warning lights, and turn signals during both day and night. Follow local regulations for equipment lighting and marking. Keep lighting and marking visible, clean, and in good working order. Replace or repair lighting and marking that has been damaged or lost.

Keep Riders Off Machine

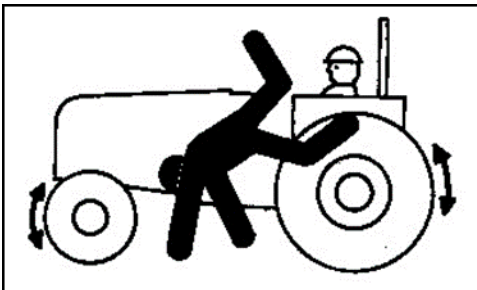

Only allow the Operator on the machine. Keep riders off.

Riders on the machine are subject to injury such as being struck by foreign objects and being thrown off of the machine. Riders also obstruct the Operator's view resulting in the machine being operated in an unsafe manner.

Observe Maximum Transport Speed

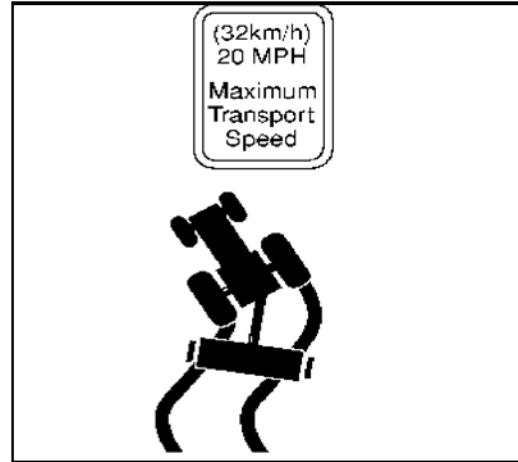

⚠ CAUTION: Be sure all bystanders are clear of Sprayer.

⚠ IMPORTANT: Transport Sprayer only with tank EMPTY to prevent Sprayer damage.

This implement is not equipped with service or parking brakes. The maximum transport speed for this implement is 20 mph (32 km/h).

Some tractors are capable of operating at speeds that exceed the maximum transport speed of this implement. Regardless of the maximum speed capability of the tractor being used to tow this implement, do not exceed the implement's maximum transport speed.

Exceeding the implement's maximum transport speed can result in:

1. Loss of control of the tractor/implement combination.
2. Reduced or no ability to stop during braking.
3. Implement tire failure.
4. Damage to the implement structure or its components.

Use additional caution and reduce speed when towing under adverse surface conditions, when turning, and when on inclines. For transport, the weight of the

EMPTY Sprayer must not be more than 1.5 times the weight of the tractor. The minimum towing tractor weight for the Utility Sprayer is 1241 lbs.

Never tow this implement with a motor vehicle. Tow only with a properly ballasted tractor.

EC Compliance Notification



⚠ WARNING: Environmental transportation hazard. A loaded machine driven on public roads has a high risk of tire failure. Do not use the machine for transporting product(s) on public roads.

Never transport with a tank filled with water or chemical(s).

Use a Signal Person

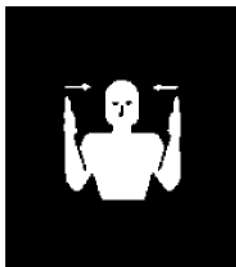

Use a signal person to direct movement of the tractor/fertilizer cart combination, whenever the tractor operator's view is obstructed.

Designate one individual as THE signal person. Always have the signal person stand in clear view. Be sure the signal person stays a safe distance away from the machine when it is moving.

Prior to starting the tractor, discuss hand signals and what each signal means to avoid

misunderstandings and confusion which could result in a serious injury or fatal accident for someone.

Keep all bystanders away whenever the machine is moved.

Use a Safety Chain

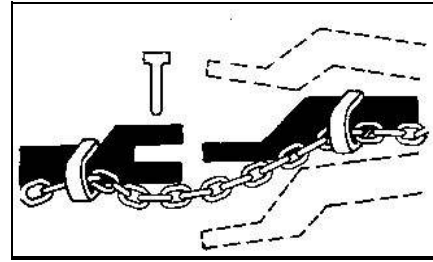

A safety chain will help control drawn equipment should it accidentally separate from the drawbar.

Using the appropriate adapter parts, attach the chain to the tractor drawbar support or other specified anchor location. Provide only enough slack in the chain to permit turning.

Tow Loads Safely



Stopping distance increases with speed and weight of towed loads and on slopes. Towed loads with or without brakes that are too heavy for the tractor or are towed too fast can cause loss of control. Consider the total weight of the equipment and its load.

Observe these recommended maximum road speeds or local speed limits which may be lower:

If towed equipment does not have brakes, do not travel more than 32 km/h (20 mph) and

do not tow loads more than 1.5 times the tractor weight.

Ensure the load does not exceed the recommended weight ratio. Add ballast to the recommended maximum for the tractor, lighten the load, or get a heavier towing unit. The tractor must be heavy and powerful enough with adequate braking power for the towed load. Use additional caution when towing loads under adverse surface conditions, when turning, and on inclines.

Avoid Overhead Power Lines

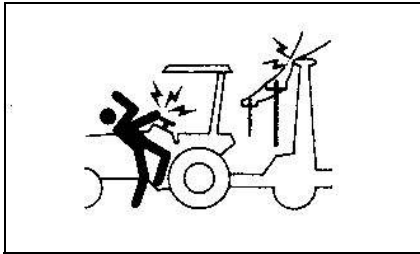

⚠️ WARNING: Keep away from overhead power lines. Serious injury or death may result.

Proceed cautiously under overhead power lines and around utility poles. Know the transport height of your machine. Electrocutation can occur without direct contact with overhead electrical lines.

Prepare for Transport

⚠️ CAUTION: Avoid serious injury or death to your or others.

Never tow the machine behind a truck or other motor vehicle. This machine is designed only to be towed with a properly sized and ballasted tractor.

Use a tractor large enough to maintain control. Properly ballast tractor for towing your machine. Refer to tractor Operator's Manual and this Manual to ensure that

machine can be safely transported with your tractor.

Be aware of height and width restrictions to avoid a collision with overpasses or other road users.

Always fold wings fully. If wing fold cylinders are removed, chain wings together to prevent accidental lowering. Fully raise frame, close hydraulic lock-up valve (if equipped) and install Transport/Service locks before transporting. Latch the tractor brakes together.

Attach a properly sized safety chain for the load being towed. Refer to [Use a Safety Chain](#).

⚠️ IMPORTANT: Do not transport on a roadway unless the machine is equipped with proper functioning lights and reflective markings or emblems.

Ensure that the lights and reflective markings or emblems are clean and visible. Contact your Fast Ag Solutions dealer for lights and lighting harnesses.

Always follow local and national regulations for equipment size, lighting and marking before driving on public roadways. You are responsible for understanding and complying with all requirements regarding roadway transport. Refer to [Use Safety Lights and Devices](#).

Transport Safely



! CAUTION: When transporting, always travel at a reasonable and safe speed which permits adequate control of steering and stopping.

Reduce speed considerably when traveling over rough ground. Be certain everyone is clear of the machine.

Do not exceed weight and speed guidelines. Refer to [Observe Maximum Transport Speed](#).

Towed loads can swerve and upset or cause loss of control. Refer to [Tow Loads Safely](#). Shift tractor into a lower gear when transporting down steep slopes or hills; never coast. Stop slowly.

Wide turns may be required with the machine in tow. Use caution in traffic and in congested areas.

To improve stability when traveling through the field, wings should be unfolded from transport position as soon as possible after leaving the roadway.

! IMPORTANT: When transporting the machine on a roadway, **ALWAYS USE** appropriate lamps and devices for adequate warning to operators of other vehicles.

Refer to [Use Safety Lights and Devices](#).

Replace Safety Signs

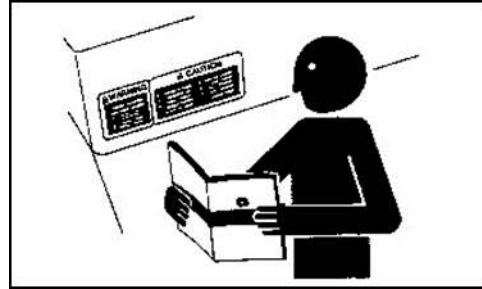

Replace missing or damaged safety signs. Use this Operator's Manual for correct safety sign placement.

Decals and decal location may vary by model.

There can be additional safety information contained on parts and components sourced from suppliers that is not reproduced in this Operator's Manual.

Your safety is involved. Failure to follow these instructions could result in serious injury or death.

General

A. Serial Number Tag



B. Decal 10208



C. Decal 800007



D. Decal 800002



E. Decal 800105

*Models with Booms Only



F. Decal 800004

*Hydraulic Power Only



G. Decal 800013



H. Decal 800112

*Models with Booms Only

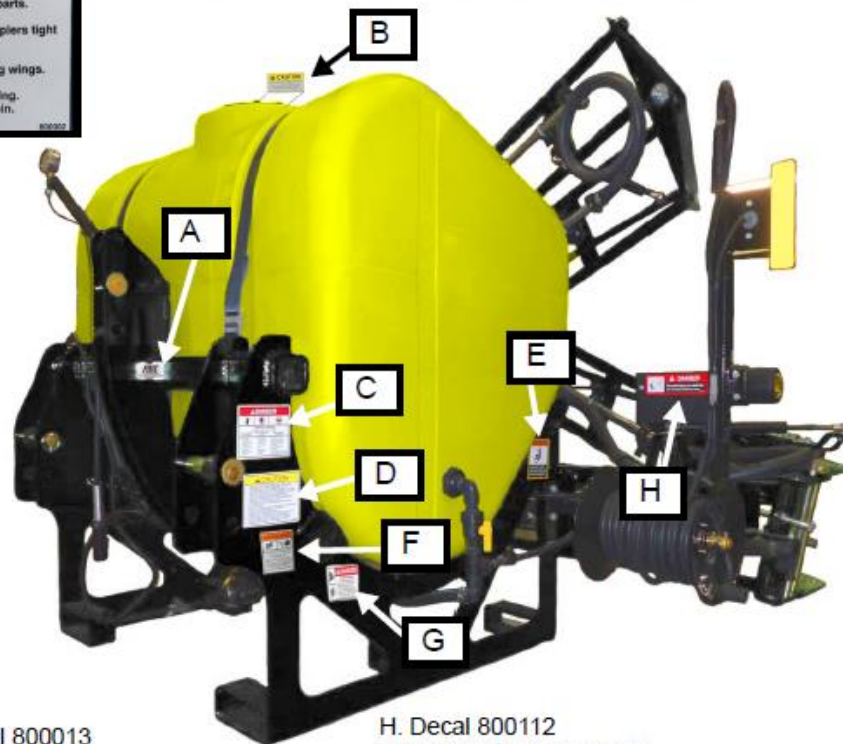

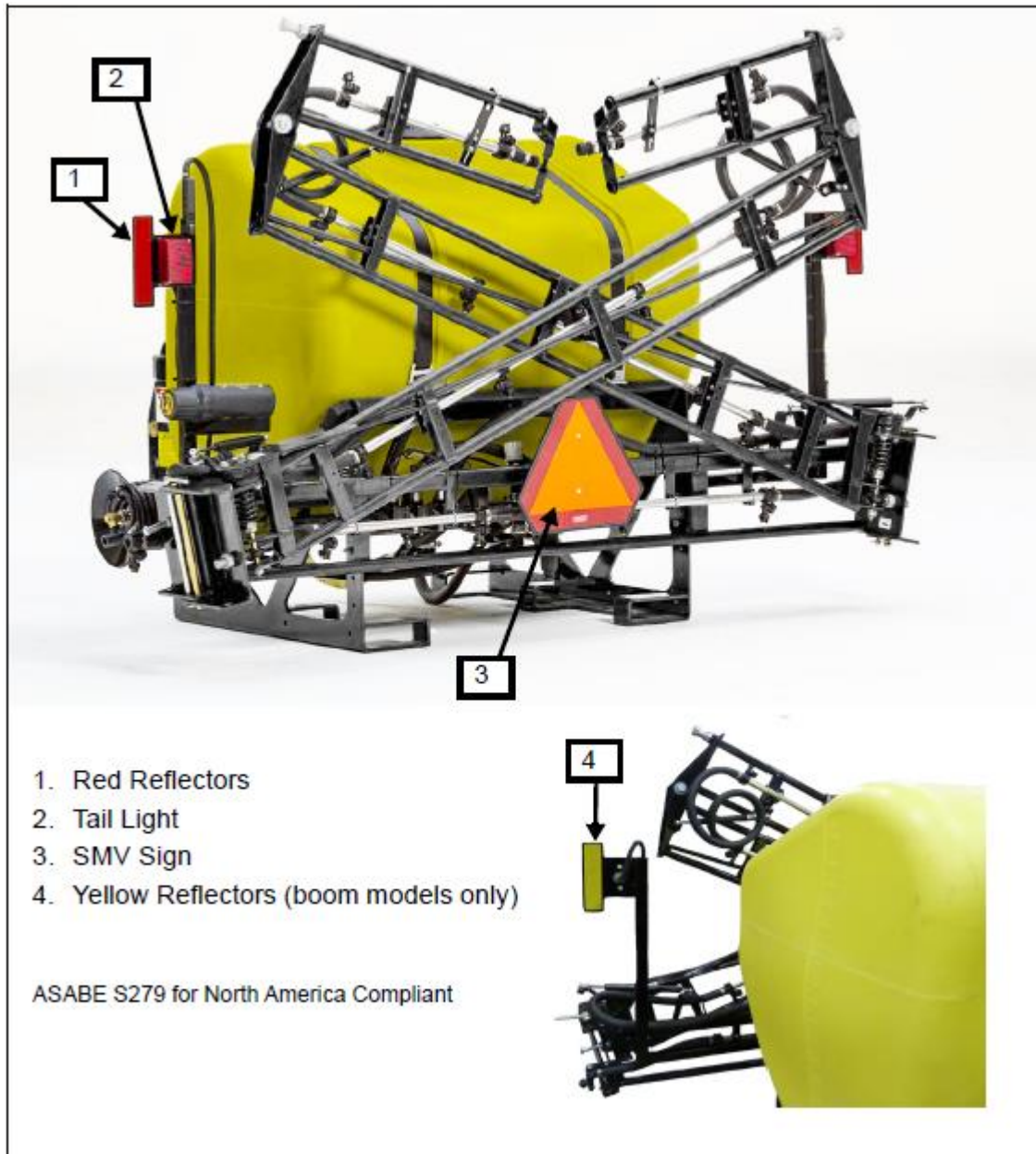
Lights and Reflectors

In addition to the safety features shown here, other components, systems, safety signs on the machine, safety messages, and instructions in the Operator's Manual contribute to the safe operation of this machine when combined with the care and concern of a capable Operator.

The construction of this implement may not meet all local or national requirements for transport on a public roadway. In regions or countries that have national certification requirements for roadway transport, it may be impossible for this implement to be approved for such roadway transport. The customer is responsible for understanding and complying with all local, regional, and national requirements regarding roadway transport.

SPECIFICATIONS

Tractor Power, Size Recommendation

▲ IMPORTANT: Verify tractor lift capacity and ensure proper ballasting.

Use the machine with a tractor providing drawbar power in the following ranges:

Model	Tractor Power Minimum, kW (HP)	Hitch Category Compatibility	Quick Hitch Compatibility
UT3P25	37.3 (50)	Cat. II & III	Yes
UT3P30			
UT3P30BL			
UT3P40			
UT3PH40			
UT3PH45			

Hydraulic System Requirements

A tractor hydraulic system with ISO hydraulic couplers is required.

Circuit	SCV Function	Flowrate	Pressure
1	Chemical/Fertilizer Pump Drive Motor, Hydraulically driven	106 LPM (27 GPM)	20.7 MPa (3000 PSI)
2	Wing Folding (Main)	15 LPM (4 GPM)	20.7 MPa (3000 PSI)
3	Wing Folding (Swing)	15 LPM (4 GPM)	20.7 MPa (3000 PSI)

Sprayer Weights

▲ IMPORTANT: Verify the main tank is empty before transporting on road.

	UT3P25	UT3P30	UT3P30BL	UT3P40	UT3PH40	UT3PH45
946 L (250 Gal.) Dry	375 kg (827 lbs.)	389 kg (857 lbs.)	288 kg (635 lbs.)	400 kg (882 lbs.)	671 kg (1479 lbs.)	688 kg (1517 lbs.)
946 L (250 Gal.) Wet	1629 kg (3592 lbs.)	1643 kg (3622 lbs.)	1542 kg (3400 lbs.)	1654 kg (3647 lbs.)	1925 kg (4244 lbs.)	1942 kg (4282 lbs.)
1136 L (300 Gal.) Dry	382 kg (842 lbs.)	396 kg (872 lbs.)	295 kg (650 lbs.)	448 kg (987 lbs.)	678 kg (1494 lbs.)	695 kg (1532 lbs.)
1136 L (300 Gal.) Wet	1887 kg (4160 lbs.)	1901 kg (4190 lbs.)	1800 kg (3968 lbs.)	1953 kg (4305 lbs.)	2183 kg (4812 lbs.)	2200 kg (4850 lbs.)



SPECIFICATIONS

Sprayer Maximum Speeds

Models	Transport	Application
All	40 KPH (25 MPH)	16 KPH (10 MPH)

Machine Dimensions & Specifications

Model	UT3P25	UT3P30	UT3P30BL	UT3P40	UT3PH40	UT3PH45
Transport Height	1.58 m (5.2 ft.)	1.83 m (6.0 ft.)	1.46 m (4.8 ft.)	1.83 m (6.0 ft.)	3.05 m (10.0 ft.)	3.05 m (10.0 ft.)
Transport Width	2.59 m (8.5 ft.)	2.59 m (8.5 ft.)	2.10 m (6.9 ft.)	2.82 m (9.3 ft.)	2.67 m (8.8 ft.)	2.67 m (8.8 ft.)
Transport Overall Length	1.60 m (5.3 ft.)	1.60 m (5.3 ft.)	1.28 m (4.2 ft.)	1.60 m (5.3 ft.)	2.29 m (7.5 ft.)	2.29 m (7.5 ft.)
Working Width	7.62 m (25.0 ft.)	9.14 m (30.0 ft.)	9.14 m (30.0 ft.)	12.19 m (40.0 ft.)	12.19 m (40.0 ft.)	13.72 m (45.0 ft.)

Sprayer Standard Features

Feature	UT3P25	UT3P30	UT3P30BL	UT3P40	UT3PH40	UT3PH45
Frame	Structural Tube Frame					
Parking Stand	Fully Integrated with Fork Pockets					
Boom	Dual Cylindrical Tube Frame					
	Manual Fold				Hydraulic Fold	
	Forward & Rear Breakaway					
	Stainless Wetboom Tube		Boomless Flat Nozzles		Stainless Wetboom Tube	
Nozzles	Single or Triple Bodies		N/A		Single or Triple Bodies	
	Flat Spray Tip		Boomless Flat Fan Nozzle		Flat Spray Tip	
	38cm-51cm (15"-20") Spacing		N/A		38cm-51cm (15"-20") Spacing	
Fluid System	Trumpet Agitation					
	50-Mesh T-Strainer Filter					
Safety	Transport Lights					



SPECIFICATIONS

Sprayer System Options

Feature	UT3P25	UT3P30	UT3P30BL	UT3P40	UT3PH40	UT3PH45
Fenceline Nozzles	N/A	Manual / Electric ¹	N/A	Manual / Electric ¹		
Foam Marker	Optional		N/A	Optional		
Tank Fill	2" Quick Fill					

<i>with Product Pump</i>	6500C 6-Roller PTO	ACE FMC-75-HYD-204	ACE 150-HYD-206²
Max. Flow	79 LPM (21 GPM)	102 LPM (27 GPM)	507 LPM (134 GPM)
Controller	N/A	TIR RC-2	Raven SCS 450 / Micro-Trak SprayMate II / 37-Pin harness (customer supplied Greenstar)
Flow Control	Manual Relief Valve	TIR Valve	Raven Valve
Section Control (with Boom)	3-Section Manual Valve	3-Section TIR Solenoid Valve	3-Section TeeJet 430 Ball Valves
Section Control (Boomless)	2-Section Manual Valve	2-Section TIR Solenoid Valve	N/A

¹ Available only with Controller: Raven SCS 450

² Available only on UT3PH40 and UT3PH45

HYDRAULIC FLOW

Regulating Hydraulic Flow to the Pump

Locate your tractor model and follow the appropriate setup instructions.

⚠ WARNING: FAILURE TO REGULATE OIL FLOW WILL CAUSE MOTOR FAILURE.

⚠ WARNING: NOT SUITABLE FOR PUMPING FLAMMABLE LIQUIDS.

Load Sensing Closed Center System (LS Closed)

Regulate oil flow with the tractor's FLOW CONTROL and FLOW LIMITER. (Do not use restrictor orifice.)

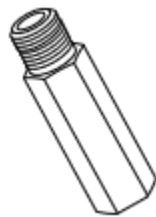

Figure 2: Flow Limiter



Figure 3: Flow Control

Setup Instructions:

1. (Optional) Remove adapter and install flow limiter in motor inlet port (marked I).
2. Close motor needle valve: loosen jam nut, screw needle valve clockwise until seated, and lock jam nut (factory setting.)
3. Shut off toolbar boom and agitation valves if equipped.
4. Adjust tractor flow control to minimum flow setting (Turtle).

5. Move hydraulic lever to "Lower/Retract" position to start pump.
6. Adjust tractor flow control until the toolbar shut-off (deadhead) pressure is within the pump's operating parameters. **Note:** If the flow limiter stops oil flow to the motor:
 - a. Move hydraulic lever to "Float" or "Neutral" to remove oil pressure from the flow limiter.
 - b. Adjust tractor flow control to a lower flow position.
7. Repeat steps 5 and 6.
8. Open the agitation valve(s).

Pressure Compensating Closed-Center System (PC Closed)

Regulate oil flow by using a RESTRICTOR ORIFICE. (Do not use flow limiter.)

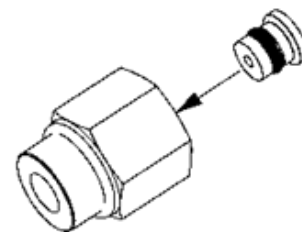

Figure 4: Restrictor Orifice

Setup Instructions:

1. Install restrictor orifice by inserting inside the adapter/restrictor body in the motor inlet port (marked I).
2. Close motor needle valve: loosen jam nut, screw needle valve clockwise until seated, and lock jam nut (factory setting.)
3. Set "Rabbit/Turtle" flow control to "Turtle".
4. Move hydraulic lever to the "Lower/Retract" position to start pump.
5. Adjust "Rabbit/Turtle" flow control and agitation valve(s) to get desired injection pressure.

Open Center System (Open)

Select a motor size closest to tractor's hydraulic system capacity. Regulate oil flow with the motor NEEDLE VALVE.

(Do not use restrictor orifice or flow limiter.)

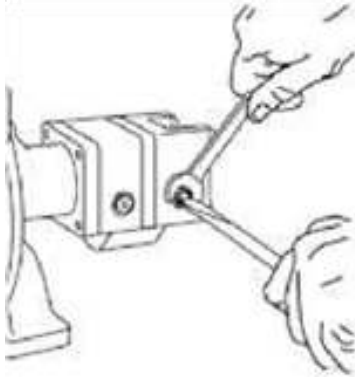

Figure 5: Closing the Needle Valve

Setup Instructions:

1. Shut off sprayer boom and agitation valves.
2. Loosen jam nut on motor and back out needle valve 3 or 4 turns counterclockwise.
3. Set tractor throttle to sprayer operating speed.
4. Move hydraulic lever to "Lower/Retract" position to start pump.
5. Screw needle valve clockwise until sprayer (deadhead) pressure is within the pump's operating parameters and lock the jam nut.
6. Open the sprayer agitation valve to get desired injection pressure.

Tractor SCV Functions

NOTE: The illustrations in this Manual are for explanatory purposes only. Your control system may differ in appearance and function.

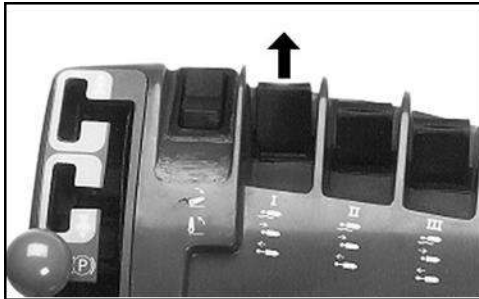

Figure 6: SCV I Pushed Forward

When the tractor's SCV I is pushed forward, the following functions are enabled:

1. Engages product pump for applying.

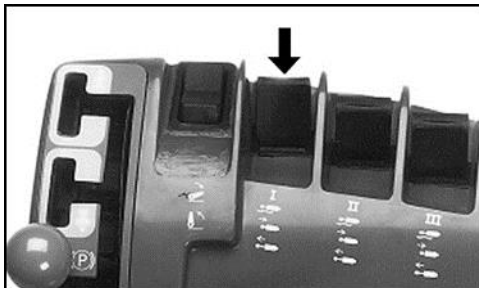

Figure 7: SCV I Pulled Backward

When the tractor's SCV I is pulled backward, the following functions are enabled:

1. Disengages product pump for transporting.

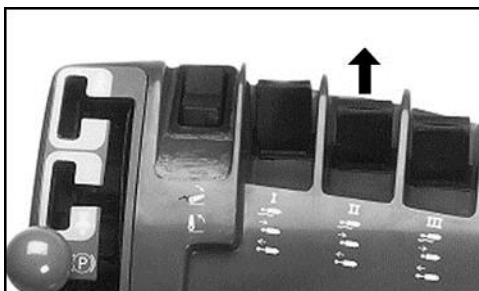

Figure 8: SCV II Pushed Forward

When the tractor's SCV II is pushed forward, the following functions are enabled:

1. Supplies hydraulic oil flow to operate implement folding functions.

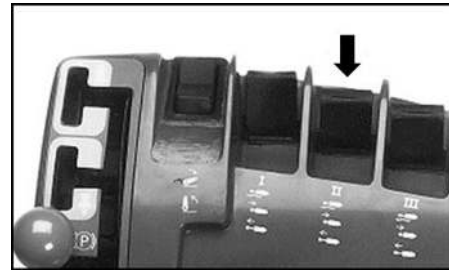

Figure 9: SCV II Pulled Backward

When the tractor's SCV II is in pulled backward, the following functions are enabled:

1. Supplies hydraulic oil flow to operate implement folding functions.

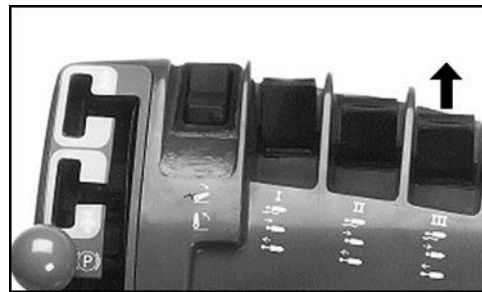

Figure 10: SCV III Pushed Forward

When the tractor's SCV III is pushed forward, the following functions are enabled:

1. Supplies hydraulic oil flow to operate implement folding functions.



Figure 11: SCV III Pulled Backward

When the tractor's SCV III is in pulled backward, the following functions are enabled:

1. Supplies hydraulic oil flow to operate implement folding functions.



PREPARING THE MACHINE

Use the Tractor Operator's Manual

Always refer to tractor operator's manual for specific detailed information regarding operation of equipment.



Assembly

Upon arrival, the Utility Sprayer will require initial assembly. This will typically be completed by a Fast Ag Solutions dealer.

Drain and Rinse Tank

The Utility Sprayer is shipped with a small amount of RV antifreeze in the tank. The tank must be drained and rinsed before use.

Drain Filters

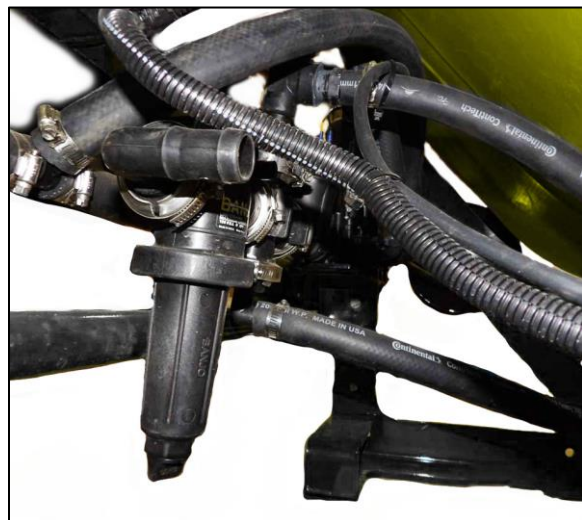

1. Place a pail under the filter.
2. Remove the drain plug from the filter.
3. Allow it to drain.
4. Replace the plug.

5. Repeat for any additional filters.
6. See [Pump Maintenance and Service](#) for any additional instructions.

Drain Tank

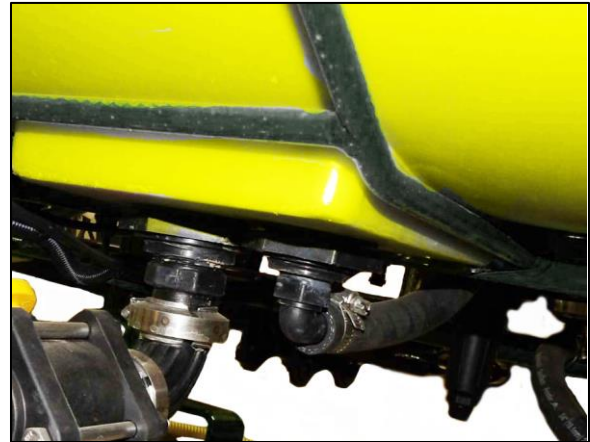

1. Locate the tank drain below the tank.
2. Place a pail or container under the drain.
3. Disconnect the fitting from the tank.
4. Allow all fluid to drain.
5. Reinstall the hose fitting.
6. Add 10 gallons of water to the tank.
7. Disconnect the fitting from the tank.
8. Allow the rinse water to drain.
9. Reinstall and tighten the hose fitting.

Connect the PTO Pump

When the Utility Sprayer is operated with a PTO Pump, the hoses will need to be connected.

1. The hoses are zip-tied to the center boom for shipping. Clip the zip ties to release the hoses.



2. Attach the 1-1/4" yellow hose to the inlet side of the PTO Pump.
 - a. Loosen the clamp and slide the hose onto the left PTO fitting.
 - b. Tighten the clamp.



3. Attach the hose to the Utility Sprayer.
 - a. Loosen the clamp.
 - b. Slide the hose onto the pump fitting.
 - c. Tighten the clamp.



4. Attach the 1" black hose to the outlet side of the PTO Pump.
 - a. Loosen the clamp.
 - b. Slide the hose onto the right-side fitting on the PTO.
 - c. Tighten the clamp.



5. Route the hose under the tank and through the support on the main frame.



6. Attach the hose to the section valves.
 - a. Loosen the clamp.
 - b. Slide the hose onto the section valve fitting. Use one hand to support the fitting as shown.
 - c. Tighten the clamp.
7. Attach the Utility Sprayer to the tractor.
8. Connect the PTO Pump.
9. See [ATTACHING](#) and [DETACHING](#) for any additional instructions.

If the hoses are too long:

1. Disconnect the PTO Pump from the tractor.
2. Disconnect the hoses from the PTO Pump.
3. Cut hoses to the length needed to fit the tractor.
4. Reconnect the hoses to the PTO Pump.

Set the (Optional) Hydraulic Motor Driven Chemical Pump

1. Install and tighten the drain plug at the bottom of the pump.
2. Set the hydraulic outlet flow to 2.8 GPM – 4.8 GPM for optimal pump output. Reference the following Performance Chart if needed.

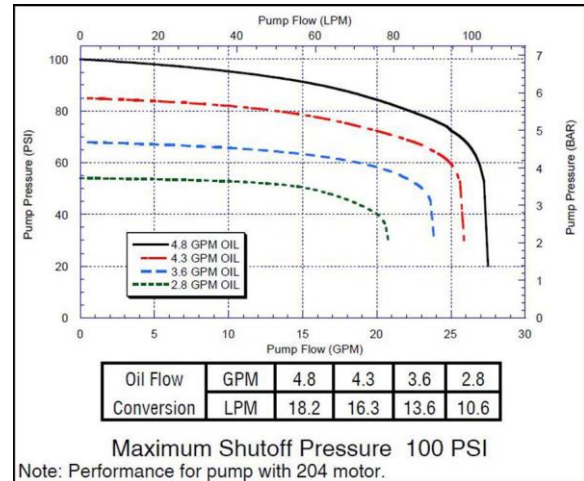

Unpack the Spray Wand

The spray wand is zip-tied to the spray wand holder for shipping. Carefully cut the ties to release it.



NOTE: The electrical harness for the taillight is also zip-tied to the spray wand holder. Only cut the ties holding the spray wand hose.

Install 3-Point Hitch Bushings and Spacers

Follow the diagram below for installing bushings or spacers as needed.

CATEGORY 2

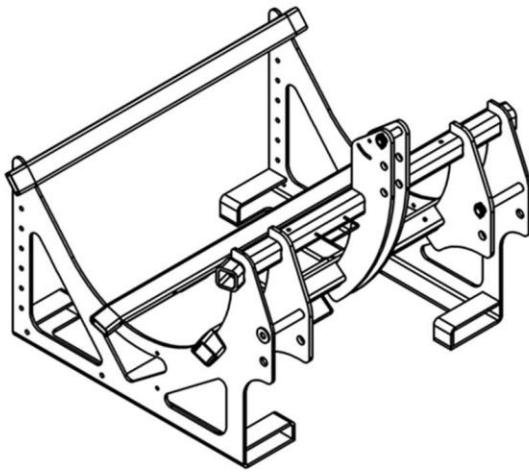

NO BUSHINGS OR SPACERS INSTALLED

**CATEGORY 2
QUICK HITCH**

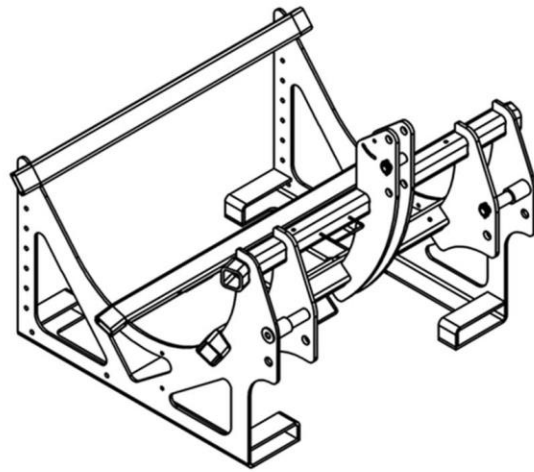

BUSHINGS INSTALLED AND SPACERS
TOWARDS THE OUTSIDE

CATEGORY 3

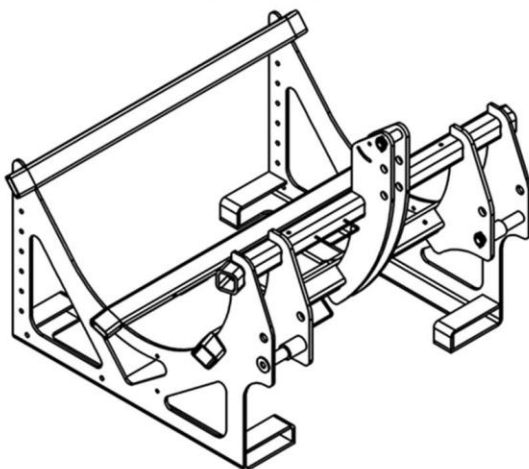

BUSHINGS INSTALLED AND
SPACERS TOWARDS THE INSIDE

**CATEGORY 3
QUICK HITCH**

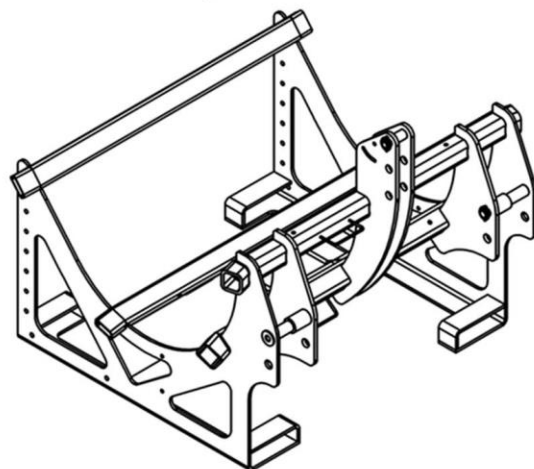

BUSHINGS INSTALLED AND
SPACERS TOWARDS THE INSIDE

Pre-Operation Checklist

Efficient and safe operation of the machine requires that each Operator reads and understands operating procedures and all related safety precautions outlined in this section. A pre-operational checklist is provided for the Operator. It is important for both personal safety and maintaining the good mechanical condition of the Sprayer that this checklist be followed.

Before operating the Sprayer, complete the following items:

1. Lubricate machine per the schedule outlined in the [LUBRICATION](#) and [MAINTENANCE](#) section.
2. Use only a tractor of adequate power and weight to operate the Sprayer. See the [SPECIFICATIONS](#) section for recommendations.
3. Gather and apply all required PPE before filling, operating, or servicing the machine.
4. As per the Intended Use, be sure that the tractor's operator station is enclosed and pressurized.
5. Read and understand the Operator's Manual and all safety signs on the equipment.
6. Read and understand the chemical manufacturer's information.
7. Confirm this Manual, any SDS sheets used for chemicals, and emergency contact information are on-board the machine.
8. Know and follow all state, federal, and local regulations for use, handling, and transport of this equipment and chemicals.
9. Inspect all hydraulic lines, hoses, fittings, and couplers for tightness. See [Tightening Hardware](#) for break-in period recommendations.
10. Check the condition and routing of all fluid hoses and lines. Be sure that all lines are routed in large arcs. Replace any that are damaged. Re-route those that are rubbed, pinched, or crimped. See [Replace Hydraulic Hoses](#).
11. Check placement components. Remove and replace any that are worn.
12. Remove all entangled material. Replace any plugged nozzles or tubes.
13. Check the weather conditions. Use the machine only when the potential for chemical drift is minimal.

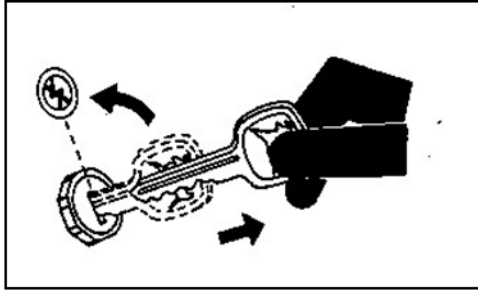
ATTACHING and DETACHING**Attach the Machine Safely**

⚠ CAUTION: Prevent personal injury caused by unexpected movement of the machine. Engage the tractor's parking brake and/or place transmission in **PARK**, shut off the engine, and remove the ignition key before working around the hitch.

⚠ CAUTION: Keep hands and body out of the hitch area. Use caution when connecting or disconnecting controls to avoid pinch points.

⚠ CAUTION: Make sure that all bystanders are clear of the working area.

⚠ NOTE: The 3-Point Hitch on your tractor may be different than the 3-Point Hitch shown. Consult the Owner's Manual for the 3-Point Hitch equipped on your tractor.

Attach the Machine to the Tractor

1. Make sure there is enough room and clearance to safely back up to the machine.
2. Lower the lift arms on the tractor to their lowest point.
3. Slowly back the tractor until holes on the hitch and machine are aligned.



⚠ IMPORTANT: If using external hitch controls, stop the tractor engine, place all controls in neutral, set the parking brake, and wait for all moving parts to stop before leaving the tractor seat.

⚠ CAUTION: Avoid crushing! Keep away from machine and hitch area when raising.

⚠ CAUTION: Avoid pinching injury! Keep hands clear of connections.

4. Slowly raise the lift arms to hook onto the machine hitch pins.
5. Check that all three lift arms have locked onto the machine hitch.

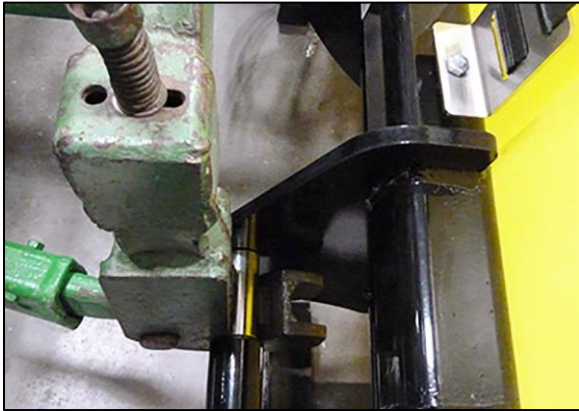

6. Engage the safety latches on the 3-Point Hitch.
7. Connect the section valve controller harness.
 - a. Align the plug ends.
 - b. Push the plug together until it is tight.

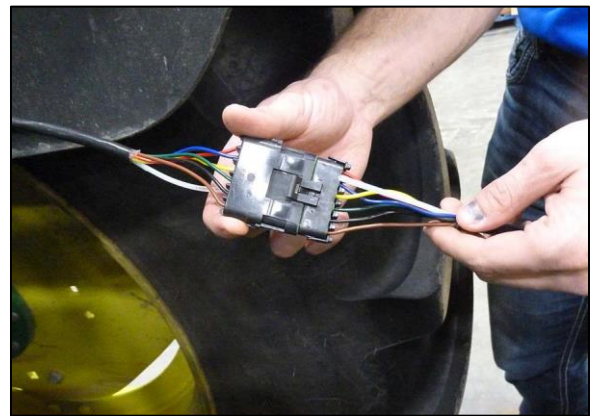

8. Connect the light harness.
 - a. Open the light harness port on the tractor.
 - b. Align the harness to the tractor's light harness port.
 - c. Push the harness into the port until it is tight.



9. If the machine is equipped with hydraulic controls:

⚠ WARNING: Prevent serious injury or death. Relieve hydraulic system pressure before connecting or disconnecting hydraulic hoses.

⚠ IMPORTANT: All hydraulic couplers must be clear of debris, dust, and sand. Use protective caps on fluid openings until ready to make connection. Foreign material can damage the hydraulic system.

- a. Check that the Sprayer hydraulic system is compatible with the tractor's hydraulics: [Hydraulic System Requirements](#). Do not operate unless tractor and applicator hydraulics are compatible.
- b. Connect the hydraulic lines by opening, aligning, and pushing the couplings into the tractor's ports until they lock.
- c. Route hoses over the hitch and connect hoses to tractor couplers. Verify couplers are securely seated. See [SCV Identification Chart](#) for hose connections.



Make Proper Hose Connections



⚠ WARNING: Escaping fluid under pressure can penetrate the skin and cause serious injury. Avoid the hazard by relieving pressure before disconnecting any hydraulic or other pressurized lines. Tighten all connections before applying pressure. Search for leaks with a piece of cardboard. Protect hands and body from high-pressure fluids.

If an accident occurs, see a doctor immediately. Any fluid injected in the skin must be surgically removed within a few hours or gangrene may result. Doctors unfamiliar with this type of injury should reference a knowledgeable medical source. Such information is available from Deere & Company Medical Department in Moline, Illinois, U.S.A.

⚠ IMPORTANT: Hydraulic hoses can fail due to physical damage, kinks, age, and exposure. Check hoses regularly. Replace damaged hoses.

Make sure the quick couplers are fully engaged. If the quick couplers do not fully engage, check to see that the couplers are the same size and type.

10. If the machine is equipped with a PTO Pump system:
- a. Align the PTO Pump with the PTO shaft on the tractor.
 - b. Push the connector onto the shaft until it locks.

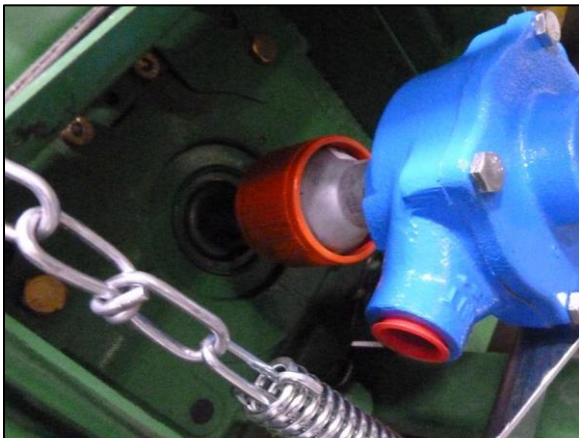

- c. Brace the torque arm against a solid member (NOT a moving part) of the tractor's frame in the direction of PTO rotation.
- d. Wrap the brace's chain tightly to the tractor frame (drawbar recommended) in the opposite direction.

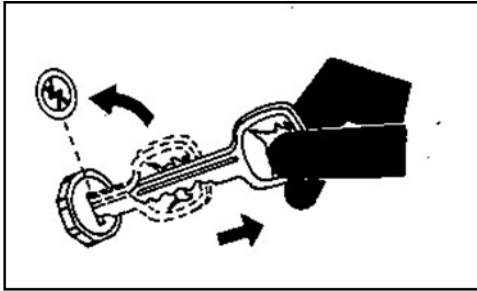
Detach Machine the Machine Safely

! CAUTION: Prevent personal injury caused by unexpected movement of the machine. Engage the tractor's parking brake and/or place its transmission in PARK, shut off the engine, and remove the ignition key before working around the hitch.

! CAUTION: Keep hands and body out of the hitch area. Use caution when connecting or disconnecting controls to avoid pinch points.

! CAUTION: Make sure that all bystanders are clear of the working area.

! CAUTION: Wait for chemical ejection to stop before approaching the machine.

! CAUTION: Use caution when lowering the machine to avoid crushing injury. Stay clear of the hitch area.

Detach the Machine from the Tractor

1. Move the machine to a level area.
2. Lower the machine to the ground.
3. Close the tank valve by turning it 90° from the hose line.



4. Fold the wings into their transport position.

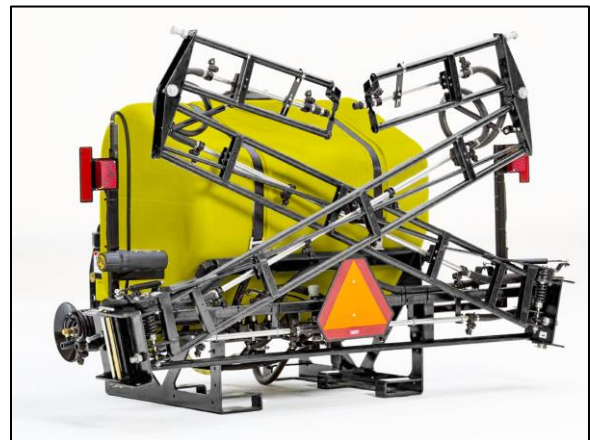

5. Disconnect the section valve controller harness.
 - a. Depress the clip on the plug of the connector while gently pulling the connector apart.
 - b. Do not jerk or force the connection apart or pull it by its cords.



6. Secure the controller cord in the cab.
7. Hang the controller connection cord on the provided cord holder on the machine.



8. Disconnect the taillight wiring harness.
 - a. Depress the clips on the coupling.
 - b. Pull the harness connection away from its port.



9. If the machine is equipped with hydraulic controls:

⚠ WARNING: Prevent serious injury or death. Relieve hydraulic system pressure before connecting or disconnecting hydraulic hoses.

- a. Relieve any hydraulic pressure.
- b. Depress each hose coupling to release them.



10. If the machine is equipped with a PTO Pump system:

IMPORTANT: Store the PTO Pump with the connection facing out or down to prevent rainwater from getting in the line.

- a. Disconnect the torque chain(s).
- b. Depress the release button fully and pull the pump away from the tractor.
- c. Store the PTO Pump by looping the torque chains around the provided cord holder on the machine.
- d. Use a bolt to secure components if necessary.

11. Slowly lower the lifting arms to unhook the machine.

12. Lower the lifting arms until the links are below and clear from the hitch pins.

13. Slowly drive the tractor away from the machine.

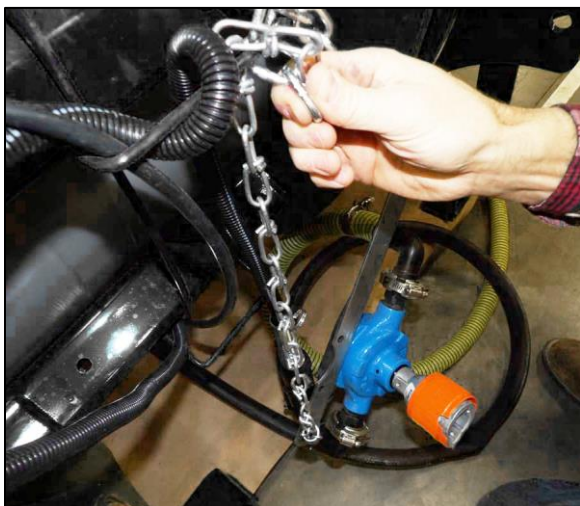

TRANSPORTING

Following Safe Transport Procedures

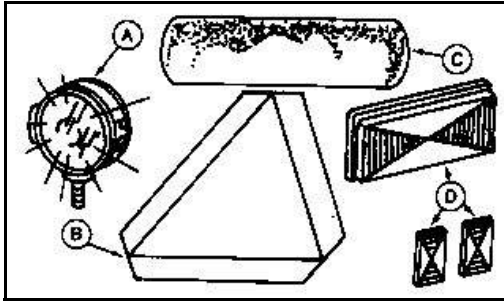

- A. Lights
- B. SMV Emblem
- C. Reflector Tape
- D. Reflectors

! CAUTION: When transporting the machine on a road or highway at night or during the day, use warning lights and devices for adequate warning to operators of other vehicles.

! IMPORTANT: Transport Sprayer only with tank **EMPTY** to prevent Sprayer damage.

Check local governmental regulations.

Various safety devices are available from your Fast Ag Solutions dealer. Keep safety items in good condition. Replace missing or damaged items.

Upward force on hitch may cause instability when transporting. Add **BALLAST** to tractor as required.

BEWARE of overhead wires and narrow gates. **KNOW** the transport height and width of your machine. (See [Machine Dimensions & Specifications](#).)

Travel at a reasonable and safe speed; **REDUCE** speed over rough or uneven terrain, slopes, and when turning. See [Observe Maximum Transport Speed](#).

BE SURE SMV emblem, reflectors, and warning lights are clean, visible, and in good condition.

BE SURE your safety chain has a strength rating greater than the gross weight of the machine.

Caution for All Machines

! CAUTION: When transporting the machine on a smooth surface road, do not exceed the maximum transport speed of 32 km/h (20 MPH). Reduce speed considerably when traveling over rough ground.



Reduce speed when turning. Do not uncouple tractor brake pedals and apply individually in an attempt to make a tighter turn.



! WARNING: Prevent serious injury or death. The machine coming near or contacting power lines can cause electrocution. **Electrocution can occur without contact. Fully lower wings before moving or transporting.**

Serious injury or death can result from contact with electric lines. Use care when moving or operating this machine near electric lines to avoid contact. Know transport height and width of machine. Check local regulations before transporting. (See [Machine Dimensions & Specifications](#) for transport height and width of machine.)

Transport with wings fully folded. Never raise or lower the center section or wings when moving.

If hydraulics are installed: After folding, ALWAYS place the fold switch(es) in the neutral position for transport.

If wing-fold cylinders are removed or damaged, chain wings together to prevent injury or death caused by accidental falling of wings on you or others.

Transporting the Machine

Notes and Checks

⚠ IMPORTANT: Transport Sprayer only with tank EMPTY to prevent Sprayer damage.

Be sure that the Sprayer is properly connected to the tractor. Always use retainers or safety pins through the 3-Point Hitch pins.

Using Warning Lights

⚠ CAUTION: When transporting the machine on a road or highway at night or during the day, use accessory lights and devices for adequate warning to operators of other vehicles. Check local governmental regulations.

Various safety lights and devices are available from Fast Ag Solutions dealer. Keep safety items in good condition. Replace missing or damaged items.

During periods of limited visibility, use pilot vehicles and use extra lights on the machine.

During normal transport, both amber warning lights will flash in unison at high intensity and both red lamps will illuminate steadily at low intensity.

When a turn is signaled, red and amber tail lamps in the direction of turn will flash at high intensity and in unison. On the opposite side, amber and red lamps will illuminate steadily at high intensity.

Keep Riders Off the Machine

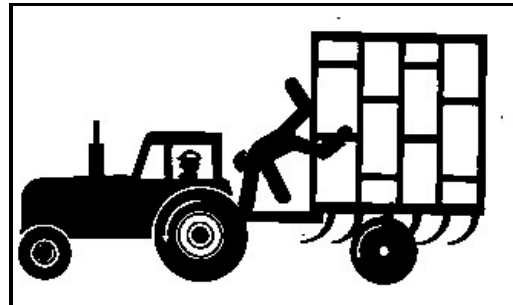

Riders are subject to injury such as being struck by foreign objects and being thrown off the machine. Riders obstruct the Operator's view resulting in the machine being operated in an unsafe manner.

Un/Folding the Machine: Manual

- ⚠ **CAUTION:** Wait for chemical ejection to stop before approaching the machine.
- ⚠ **CAUTION:** Keep away from the pivot area(s) between wings when folding/unfolding to avoid pinching.
- ⚠ **CAUTION:** Be sure all bystanders are clear of the Sprayer.
- ⚠ **CAUTION:** Engage the parking brake with all controls in neutral and wait for all parts to stop before proceeding.
- ⚠ **NOTE:** Wings must be unlocked at the pivot before unfolding.

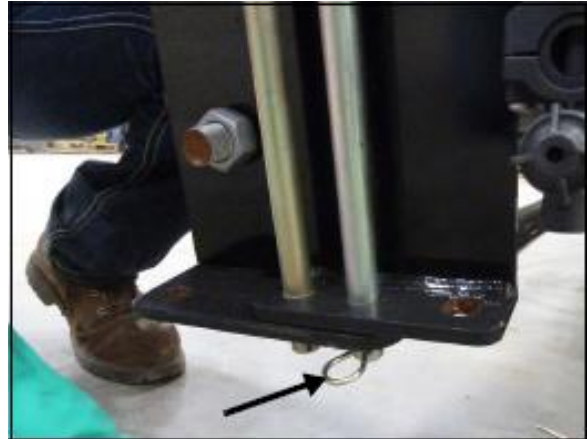

Unfold the Boom: Manual

Unfolding of the left wing (boom section) occurs first.



1. Pull the hair pin to release the lock pin.
2. Pull the lock pin all the way out of the frame.
3. Hold the top of the folded flip wing with both hands and walk it away from the machine's frame.



4. Rotate the wing 180° to full extension into its field position.



5. Insert the lock pin through the wing and frame and the boom pivot.
6. Place the lock pin in the hole on the tank's side of the boom to secure the wing in position.



7. Insert the hair pin on the bottom to secure it.



8. Hold the flip wing with both hands and rotate it 180°.
 - a. The gas shock will pull the wing into position.
 - b. The wing will rest on the stop bolt.



NOTE: The gas shocks provide an over-center force to hold the flip wings in their storage and field positions.

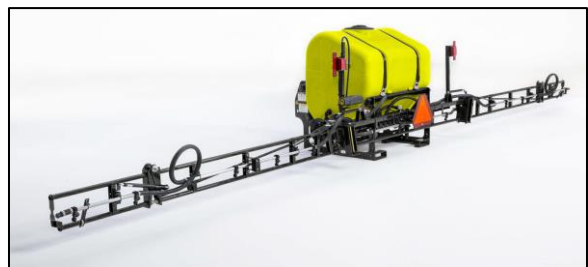

9. Repeat the procedure for the other side.

Fold the Boom: Manual

Folding of the right wing (boom section) occurs first.

1. Hold the flip wing with both hands.
2. Fold it 180°.
 - a. Hold the with both hands until it is fully folded.
 - b. The flip wing sits over the main wing. The gas shock pulls the flip wing toward the main wing after 90° and then holds the wing in place.



3. At the boom pivot, remove the hair pin to release the lock pin.

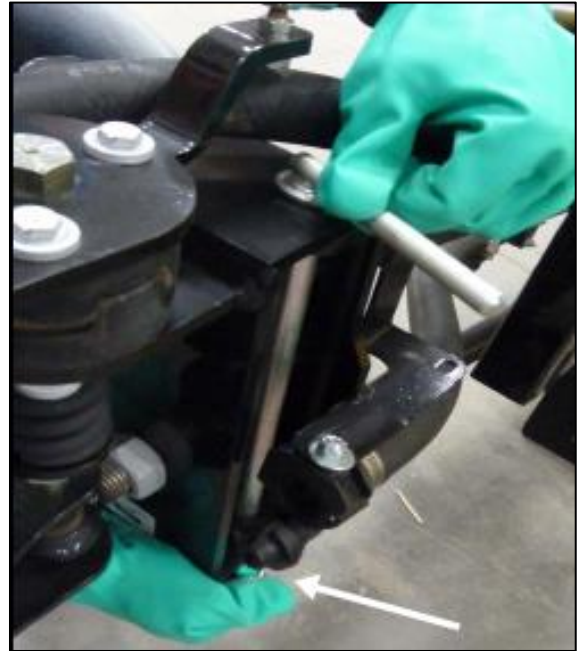

4. Pull the locking pin all the way out.



5. Hold the top of the folded flip wing with both hands and walk the main wing all the way to the Sprayer's frame.



6. Insert the lock pin in the wing pivot through the top and bottom holes. Put the pin in the center hole when the main wing is folded in.



7. Insert the hair pin into the locking pin to secure it.

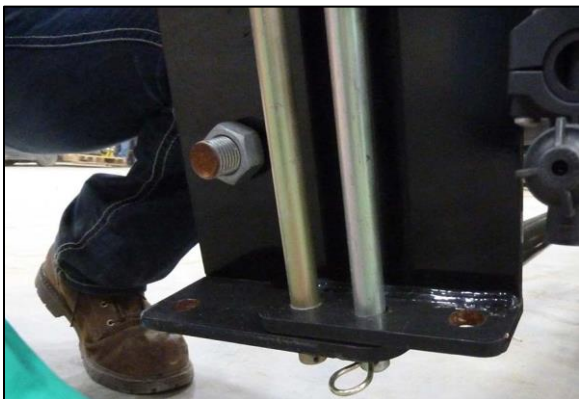

8. Repeat the process for the other side.



Un/Folding the Machine: Hydraulic

- ⚠ **CAUTION:** Wait for chemical ejection to stop before approaching the machine.
- ⚠ **CAUTION:** Keep away from the pivot area(s) between wings when folding/unfolding to avoid pinching.
- ⚠ **CAUTION:** Be sure all bystanders are clear of the Sprayer.
- ⚠ **CAUTION:** Engage the parking brake with all controls in neutral and wait for all parts to stop before proceeding.

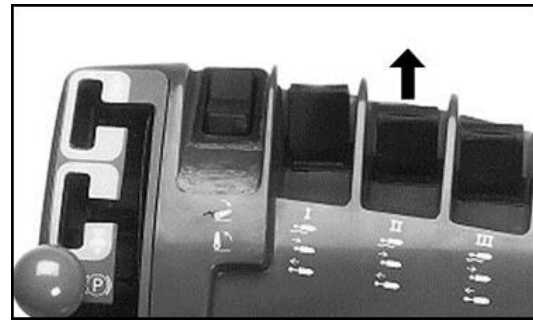

Unfold the Boom: Hydraulic

The wing sections fold by pressing the control button (switch) in the tractor cab. The left and right sides of the machine unfold at the same time.

- ⚠ **CAUTION:** Remain alert to hazards, people, and objects in the surrounding area and above the machine as its wings are unfolding.
- ⚠ **NOTE:** The switch controlling the wings depends on the arrangement of hydraulic hoses.

Normally, the pump is on SCV I, the main wings on SCV II, and the swing wings on SCV III.

Control switches may vary. Refer to your tractor's Manual for instructions.

1. While seated in the operator's station, push the main wings' switch back to fold them. Continue folding until movement stops and the main wings are against the main wing section.

2. Push the swing wings' switch to fold them.
3. Continue to fold the swing wings until movement stops and the wings are in their field position.



4. Ensure all wings have unfolded fully and are straight before use.

NOTE: If the swing wings do not unfold, verify that the latch has unlatched.

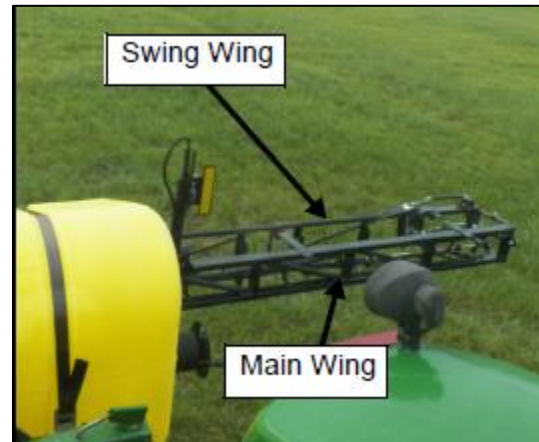

Fold the Boom: Hydraulic

The wing sections fold by pressing the control button (switch) in the tractor cab. The left and right sides of the machine fold at the same time.

CAUTION: Remain alert to hazards, people, and objects in the surrounding area and above the machine as its wings are folding.

NOTE: The switch controlling the wings depends on the arrangement of hydraulic hoses.

Normally, the pump is on SCV I, the main wings on SCV II, and the swing wings on SCV III.

Control switches may vary. Refer to your tractor's Manual for instructions.

1. While seated in the operator's station, pull the swing wings' switch back to fold them. Continue folding until movement stops and the swing wing is against the main wing section.

2. Pull the main wings' switch to fold them.
3. Continue to fold the main wings until movement stops and the wings are in their transport position.

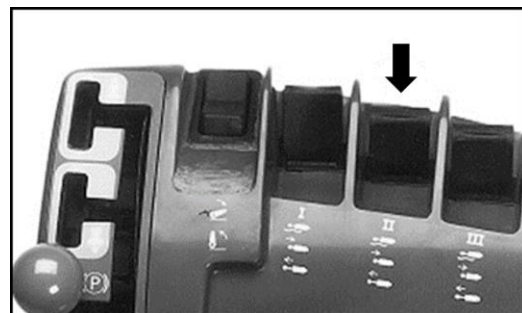

FIELD OPERATION



Figure 12: Machine in Field Position

While the machine is in its field position, inspect the following items.

1. Wing sections
 - a. Check for bent or damaged components.
 - b. Repair or replace any damaged components before use.
2. Wet booms and hoses
 - a. Correct any pinches, kinks, wear, or damage. Replace worn or damaged parts.
 - b. Check that connections are tight and not leaking. Tighten if necessary.
3. Nozzles
 - a. Check for damaged, loose, or missing nozzles.
 - b. Replace damaged or missing nozzles and tighten those that are loose.
4. Breakaway clutch
 - a. Each boom is designed with a breakaway clutch located between the center wing and the main wing sections. The breakaway clutch protects the boom from mechanical damage if the wing section(s) encounters an obstacle.
 - b. Confirm that the clutch is aligned correctly and lubricated.

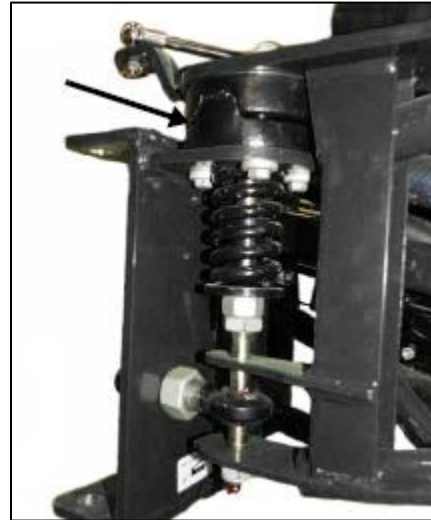
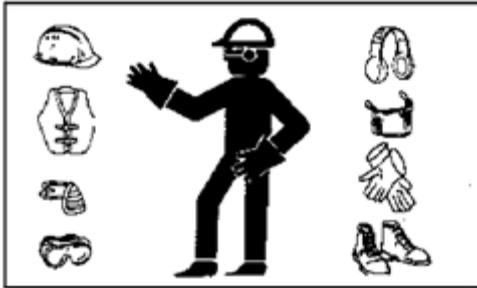

Figure 13: Breakaway clutch

Before use:

1. Read and understand the Operator's Manual and all safety signs on the equipment.
2. Follow the [Pre-Operation Check List](#).
3. Use only when the potential for chemical drift is at a minimum.
4. Be aware of obstacles and hazards in the field.
5. Do not allow riders on the machine or the tractor.
6. Clear the area of bystanders.
7. Calibrate the machine, or verify the calibration is correct for the job.
8. Calculate the amount of water and chemical needed for the field(s).
9. Attach the machine to the tractor. See [ATTACHING and DETACHING](#).
10. Review the location and function of all controls.
11. Put on PPE. Fill the tank with the exact amount of chemical solution needed.
12. Stop the tractor, set the parking brake, remove the key, and wait for all moving parts to stop before leaving the tractor seat.
13. Unfold the wings (booms.) See [Unfolding the Machine](#).

FILLING THE TANKS

! CAUTION: Prevent serious injury or death.

Check chemical or fertilizer M/SDS for proper handling instructions. Follow the chemical manufacturer's instructions exactly.

Toxic chemicals can enter the body by breathing spray or contact with bare skin.

Do not take a chance with your health and safety.

Filling the Product Tank

! CAUTION: Add only the amount of liquid to the tank that is required for the job.

! CAUTION: Keep your face away and open the tank cover slowly. Pressurized chemical vapors or mist may escape.

! CAUTION: Avoid pinching injury. Keep your hands on top of the tank's lid when turning it.

! IMPORTANT: Transport the machine with an **EMPTY** tank to prevent machine damage.

! IMPORTANT: Do not run the pump dry - damage may occur.

! IMPORTANT: Clean dirt and dust from the tank cover and surrounding area

to prevent dirt from getting into the tank.

! NOTE: The tank must be level for accurate volume readings.

1. Transport the machine to the fill area or use a fill truck in the field.
2. Lower the machine to the ground.
3. Stop the tractor's engine, place all controls in neutral, set the parking brake, remove the ignition key, and wait for all moving parts to stop before filling the tank.
4. Close the tank valve by turning the valve handle 90° from the hose line.
5. Remove the tank cover by turning the cover counterclockwise to open.
6. Lay the cover against the side of the tank. It is tethered to the tank.



7. Follow the chemical manufacturer's directions for adding chemical to the tank.
8. Insert a water hose into the tank. Be sure the hose is far enough into the tank to prevent spilling. Hold the hose in the tank to prevent it from coming out of the tank.
9. Slowly turn on the water supply. Use a low pressure to prevent splashing and spilling.
10. Fill the tank with the required amount of solution. Use the tank scale on the side as a guide. **Do not overfill the tank.**

11. Lift the water hose above the tank before turning off the water supply to prevent drawing chemicals into the hose line.
12. Turn off the hose and allow all fluid to drain from it before removing it from the tank area.
13. Remove and properly stow the hose.
14. Replace the cover by turning it clockwise until it is tight.

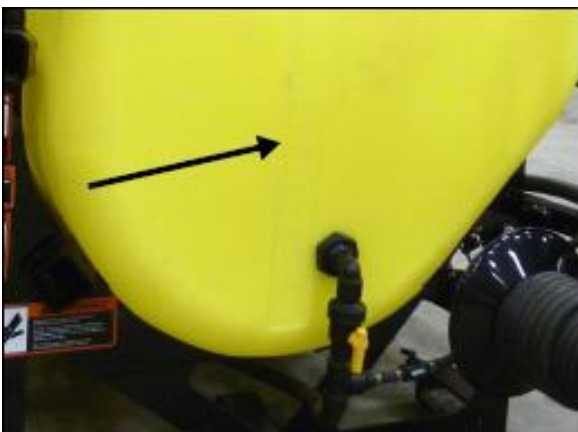

Filling the Fresh Water Rinse Tank



Each machine is equipped with a freshwater rinse tank. Fill the rinse tank with clean freshwater whenever rinse water has been used. Do not allow this tank to run low on fresh water.

The rinse tank should only be used when a running water source is not available. It is not a substitute for washing with fresh running water.

⚠ WARNING: Do not drink the water from the rinse tank.

The rinse tank water may become contaminated with sprayer chemicals or other contaminants.

Operators must always thoroughly wash according to the chemical manufacturer's instructions after handling chemicals, using this machine, and before eating or drinking.

1. Twist the cover on the top of the rinse tank and open it.
2. Fill the tank with clean fresh water only.
3. Replace and tighten the cover.

Use the Rinse Tank

1. Turn the lever on the spigot to open it.
2. Close the spigot when finished.

Drain the rinse tank completely after using the machine and before storing it.

Filling the Foam Tank

See [FOAM MARKER](#).

CONTROLS

Agitation Pump

The Utility Sprayer is equipped with an Agitation Pump that circulates liquid in the main tank. The circulation maintains constant mixing of chemicals in the main tank.

The valve on the Agitation Pump controls the amount of liquid released to the boom or spray wand.

- Partially open the valve for normal operation.
- Open the valve more to decrease pressure to the booms or spray wand.
- Close the valve more to increase pressure to the booms or spray wand.



Figure 14: Agitation Pump control valve

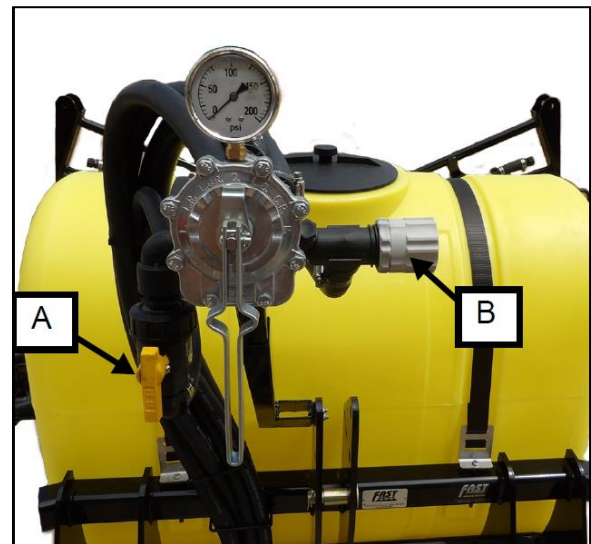

Figure 15: Control valve in normal working position

Optional Agitation Pump Valve Bar

The Agitation Pump valve may be located with the pressure gauge at the front of the main tank.

Agitation pressure is adjusted using the valve (1). Pressure is adjusted using the dial (B).



The height of the pressure gauge and agitation valve may be adjusted.

1. Loosen the bolt on the mounting bar.
2. Slide the insert to the desired height.
3. Tighten the bolt.

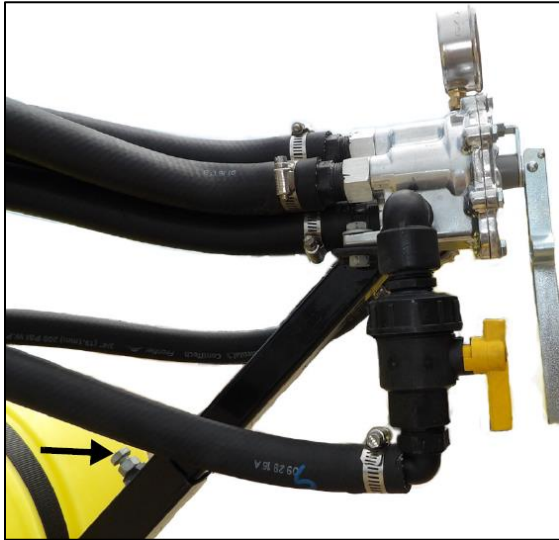

The angle of the pressure gauge can be adjusted.

1. Loosen the nuts on the lower bolt at the base of the bar.
2. Slide the bolts along the track to the desired angle.
3. Tighten the nuts.



Section Valves

The section valves operate the solution flow to the boom sections. Switches on the valve control box turn the boom sections on or off.

Pressure is monitored on the pressure gauge. Pressure can be adjusted by actuating the pressure switch on the control pad or by adjusting the agitation valve.

NOTE: The number of valves may vary by model.

Section valves are mounted below the tank in front of the center boom section.

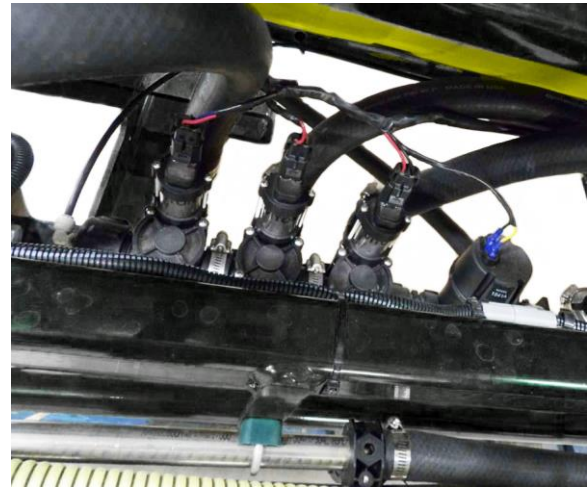

Figure 16: 30-foot Boom model

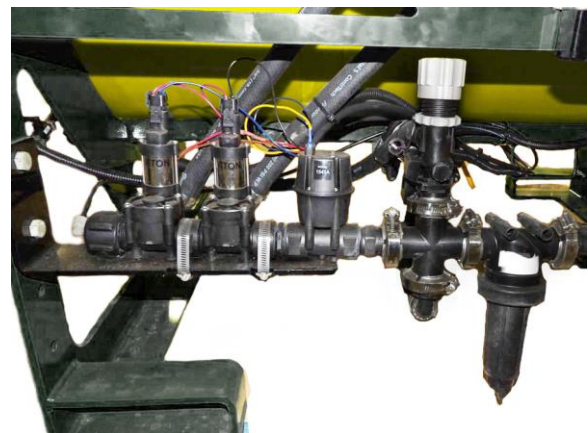
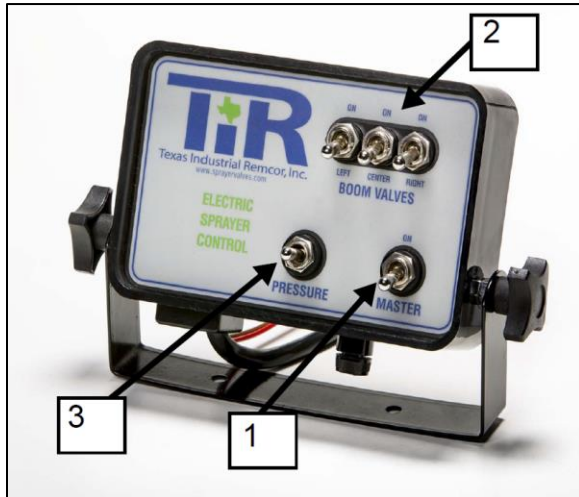

Figure 17: Boomless model

Section Valve Controller

A representative Valve Controller is shown here. The Valve Controller equipped on your machine may differ.



1. Master Switch: Controls power to the Boom Switches. Always use this switch to shut off the entire boom.
2. Boom Switches: Three on/off switches for individual boom sections.
3. Regulator Switch: Forwards or reverses the regulator motor which raises or lowers the spraying pressure. Small pressure changes can be made by jogging the switch up or down.

Find a convenient place to mount the console and use the holes in the mounting bracket as a template to drill holes for its mounting screws. Quick disconnects permit the permanent installation of the control box in the tractor cab.

BOOM HEIGHT ADJUSTMENT

Adjust the Height of the Boom

The height of the sprayer's booms is adjustable between 18 to 60 inches (46 to 152 cm) depending on the tractor's size and height.

Height is regulated by the tractor lifting or lowering the sprayer. The size of the tractor affects the height of the sprayer. When height adjustment is necessary, follow these steps.

Adjust the height of the boom according to the instructions of the chemical being applied. If not specified, adjust the booms to be 18 to 20 in (46 to 51 cm) above the target of the spray. The spray pattern from the nozzles should overlap by a couple of inches above the spray target.

Calculate the height adjustment needed to determine where to make the adjustment.

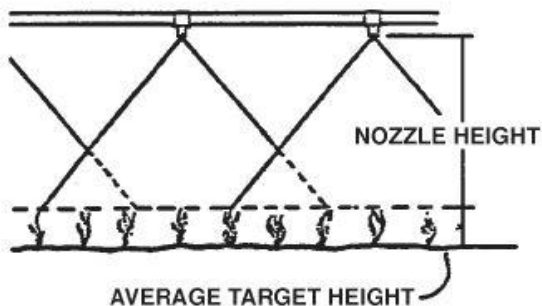

NOTE: Height adjustments can be made at the 3-Point Hitch, the wings, or both.

Hitch Adjustment

CAUTION: Prevent personal injury caused by unexpected movement of the machine. Engage the tractor's parking brake and/or place its transmission in **PARK**, shut off the engine, and remove the ignition key before working around the hitch.

1. Close the main tank valve.
2. Disconnect the sprayer from the tractor.
3. Remove the locking pin; then remove the hitch pins.
4. Move the center pin to the upper-, middle-, or lower-position.
5. Reinstall the locking pin.
6. Move the side hitch pins to the upper- or lower-position.
7. Reinstall the locking pin.

IMPORTANT: Both side hitch pins must be installed at the same level position.

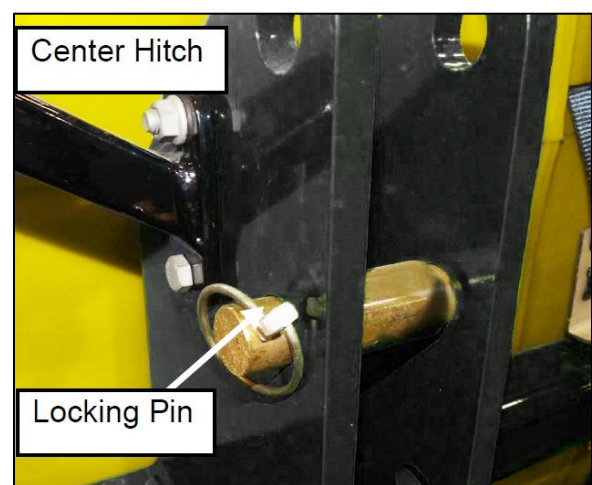
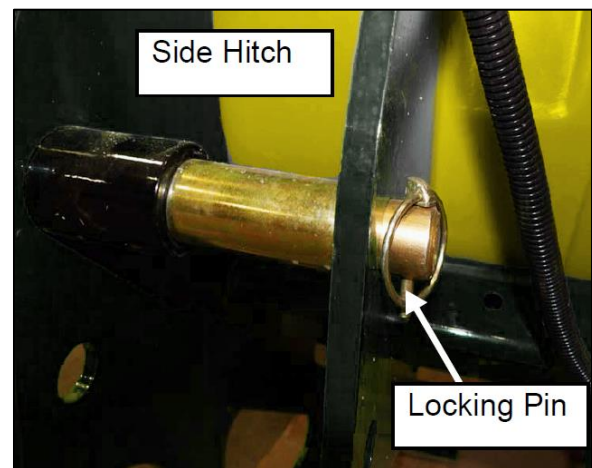

Boom Height Adjustment for Manual Models Only



1. Close the main tank valve.
2. Lower the sprayer to the ground.
3. Disconnect the sprayer from the tractor.
4. Unfold the main wing sections.
5. Place blocks under wings and center boom section to support.
6. Uninstall the three bolts holding the boom to the frame.
7. Repeat on the other side of the frame.
8. Move the boom up or down aligning with the holes in the frame.
9. Reinstall and tighten all bolts to secure the boom. See [Install 3-Point Hitch Bushings and Spacers](#).

Leveling the Booms

For most accurate flow rates and performance, the booms should be level.

1. The sprayer must be on a level surface. Be sure the main frame is level before adjusting the booms.
2. Fold out the wings.
3. Level across the main wing and flip wings.
4. For the main wings, tighten or loosen the nuts on the eye bolt connecting each main wing to the center boom plate.
 - a. One may also use the eyebolt assembly of the [Breakaway Clutch](#) to level the main wings.

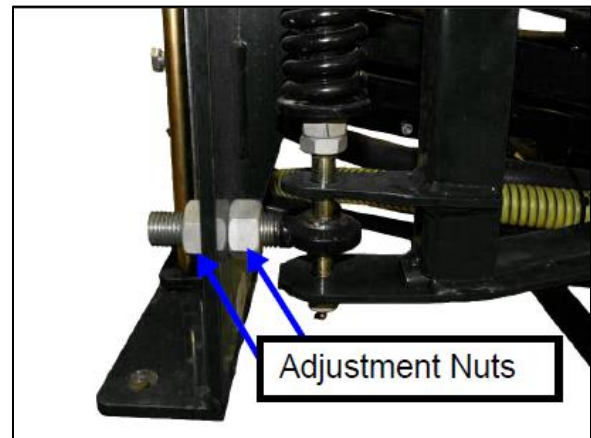

5. For the flip wing, tighten or loosen the stop bolt at the inside of the boom.

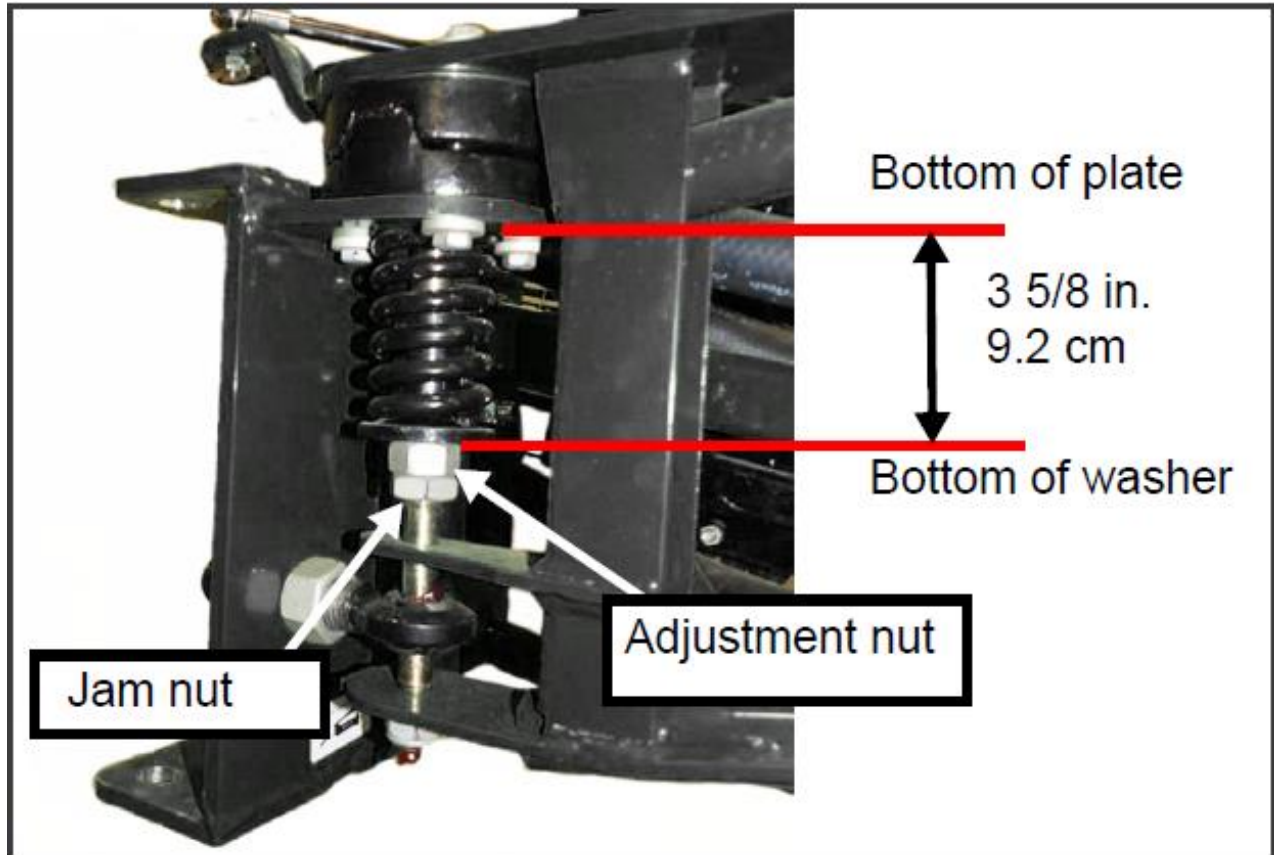

Breakaway Clutch Tension

Measure from the bottom of the plate to the bottom of the washer. The standard measurement is 3-5/8" (9.2 cm).

To adjust breakaway clutch tension:

1. Loosen the jam nut.
2. Adjust the nut below the spring.
 - a. Tighten to increase pressure.
 - b. Loosen to decrease pressure.
3. Tighten jam nut to secure.
4. Check boom leveling after adjusting breakaway clutch tension.

SPRAYER CALIBRATION

A sprayer can only apply the proper amount of chemicals when each component in the system is functioning properly. Chemical action in the field is dependent upon the accurate application of minute amounts of the spray compound. A complete calibration of the machine is required at the start of each season or when changing chemicals during the spray season.

It is the responsibility of the customer to determine the amount of chemical that they want to apply for their particular application. Many factors affect how much chemical is applied such as nozzle flow rate, chemical circuit pressure, pump speed, and ground speed, to name a few. In this section, instructions are given on how to accurately determine flow rates or application rates and how to change them. It is recommended that this procedure is followed carefully so you know exactly how much chemical is being applied.

Work closely with your chemical supplier, nozzle manufacturer, and pest control specialists to equip and operate your machine to obtain the best results. Several nozzle types are available for the sprayer. Use the type appropriate for your application.

Engine RPM

Although the exact value of the engine speed is not particularly important to sprayer function, it is recommended that it always be set at 2/3 or more off full-throttle position. This will ensure that there will be sufficient oil flow through the hydraulic system and sufficient power to maintain the ground speed.

Select the desired engine RPM and always perform the calibration and run in the field at the same setting.

If your sprayer is equipped with a PTO-driven pump, run the engine RPM to achieve 540 PTO RPM.

Automatic Controller Calibration (if equipped)

The controller must be set and calibrated for your specific machine. Refer to the Controller's Manual and follow its calibration procedure. Use the same controller settings during sprayer component calibrations as used in the field.

Ground Speed Calculation

For optimum spraying results, it is important to maintain a known, constant speed to spray the required chemical over a given area. Because of wheel slippage, the operator cannot rely on the tractor speedometer reading to give the value of true ground speed. The unit must be timed over a known distance to determine true ground speed.

To calibrate, follow this procedure:

1. Mark off a distance of 100, 200 or 300 feet (328m, 656m, 984m) in the field to be sprayed (longer distances provide greater accuracy).
2. Place the tractor in the proper gear for a speed between 6 MPH and 8 MPH (9.5 KPH and 13 KPH) and at the selected engine RPM.
3. With the tank half-full of water, drive the tractor and sprayer through the measured distance.
4. Record the time required to travel the measured distance.

⚠ IMPORTANT: Always operate at the engine RPM that will be used while spraying the field.

If the machine is equipped with the automatic controller, the ground speed can be changed by up to 20% without making adjustments.



SPRAYER CALIBRATION

However, do not decrease the throttle below its 2/3 setting.

Travel Timetable

Speed mph	Time In Seconds To Travel			Time To Travel 1/2 mile minutes:seconds
	100 ft.	200 ft.	300 ft.	
5.0	13.6	27.3	40.9	6:00
5.4	12.6	25.3	37.8	5:33
5.6	12.2	24.4	36.5	5:21
5.8	11.8	23.5	35.3	5:10
6.0	11.4	22.7	34.1	5:00
6.2	11.0	22.0	33.0	4:50
6.4	10.7	21.3	32.0	4:41
6.6	10.3	20.7	31.0	4:33
6.8	10.0	20.1	30.1	4:23
7.0	9.7	19.5	29.2	4:17
7.2	9.5	18.9	28.4	4:10
7.4	9.2	18.4	27.6	4:03
7.6	9.0	17.9	26.9	3:57
7.8	8.8	17.5	26.3	3:52
8.0	8.5	17.0	25.6	3:45
8.2	8.3	16.6	24.9	3:40
8.4	8.1	16.2	24.4	3:34
8.6	7.9	15.8	23.7	3:29
8.8	7.7	15.5	23.2	3:25
9.0	7.6	15.2	22.7	3:20
9.2	7.4	14.8	22.2	3:16
9.4	7.3	14.5	21.8	3:11
9.6	7.1	14.2	21.3	3:08
10.0	6.8	13.6	20.5	3:00

Speed km/h	Time In Seconds To Travel			Time To Travel 1 kilometer minutes:seconds
	30.5 m	61.0 m	91.4 m	
7.0	15.9	31.7	47.6	8:44
7.5	14.8	29.5	43.2	8:08
8.0	13.6	27.3	40.9	7:30
8.5	12.9	25.9	38.7	7:05
9.0	12.2	24.4	36.5	6:41
9.5	11.6	23.2	34.7	6:21
10.0	11.0	22.0	33.0	6:02
10.5	10.5	21.0	31.5	5:46
11.0	10.0	20.1	30.1	5:29
11.5	9.6	19.2	29.2	5:21
12.0	9.1	18.2	27.3	5:00
12.5	8.7	17.5	26.3	4:49
13.0	8.4	16.8	25.3	4:38
13.5	8.1	16.2	24.4	4:27
14.0	7.8	15.7	23.5	4:19
14.5	7.6	15.2	22.7	4:10
15.0	7.3	14.7	22.0	4:02
15.5	7.1	14.0	21.3	3:55
16.0	6.9	13.8	20.7	3:47



Nozzle Calibration

Boom Spray Nozzles

The spray nozzles on your sprayer are XRC11002. Refer to the calibration chart below. Using tractor speed, nozzle size, and desired gallons per acre (GPA), find the pressure (PSI) necessary to achieve your GPA.

NOTE: Lower pressure settings will result in less spray drift.

Standard Calibration Chart for 20" Spacing							
Tip Size	PSI	GPM/ Nozzle	GPA				
			4 MPH	5 MPH	6 MPH	8 MPH	10 MPH
XRC11002	15	0.12	8.9	7.1	5.9	4.5	3.6
	20	0.14	10.4	8.3	6.9	5.2	4.2
	30	0.17	12.6	10.1	8.4	6.3	5.0
	40	0.20	14.9	11.9	9.9	7.4	5.9
	50	0.22	16.3	13.1	10.9	8.2	6.5
	60	0.24	17.8	14.3	11.9	8.9	7.1

Boomless Spray Nozzles

The spray nozzles on your sprayer are XT020. Refer to the calibration chart below. Using tractor speed, nozzle size, and desired gallons per acre (GPA), find the pressure (PSI) necessary to achieve your GPA.

Boomless Calibration Chart for a 48" Height							
Tip Size	PSI	GPM/ Nozzle	GPA (30' Swatch)				
			4 MPH	5 MPH	6 MPH	8 MPH	10 MPH
XT020	30	1.7	27.2	21.8	18.0	13.6	10.8
	40	2.0	32.0	25.6	21.2	16.0	12.8
	50	2.2	35.2	28.2	23.4	17.6	14.0
	60	2.4	38.4	30.6	25.6	19.2	15.4

See [Adjust Ground Speed](#) for general speed recommendations.

SPRAY WAND

A spray wand is provided for use in small areas such as fence lines.

- ⚠ **CAUTION:** Engage the parking brake with all controls in neutral and wait for all parts to stop before proceeding.
- ⚠ **CAUTION:** Keep away from lock area and hose reel to avoid pinch points.
- ⚠ **CAUTION:** Do not use the spray wand in windy conditions.
- ⚠ **CAUTION:** Always keep the wand pointed away from you and others.

1. Turn on the product pump.
2. Open the main tank valve by turning the valve handle in-line with the hose.

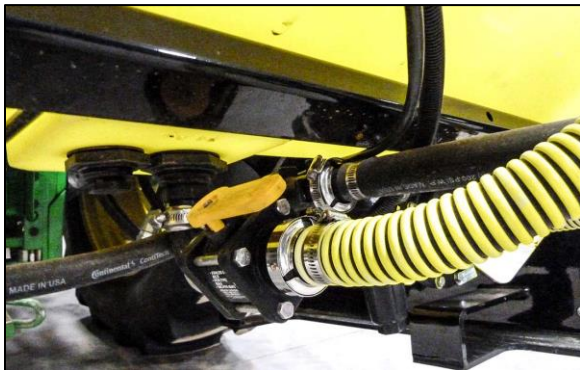

3. Unlock the hose reel by pulling and turning the pin so that the ring rests on top of the post.



4. Turn the handle clockwise to unwind a small amount of hose to loosen the wand.



- Remove the wand from its holder by pulling up on the wand handle until the wand clears the holder.



- Set the tank agitation valve halfway between its open and closed positions.
 - Close the valve more to increase wand pressure.
 - Open the valve more to decrease wand pressure.



- Open the wand valve by turning its handle in-line with its hose.



- Point the wand at the spray target and squeeze the trigger on the wand to spray.
- Pull the hose from the reel as needed to reach the spray target.



- Release the wand trigger to stop spraying.

⚠ IMPORTANT: Do not fully close the agitation valve while operating the wand. Excess pressure may damage the product pump and spray wand.

11. Close the wand's valve when finished by turning its handles 90° from its hose.



12. Return the wand to its holder.



13. Wind up the hose by turning the reel handle counterclockwise.



14. Lock the hose reel pin by pulling the pin out slightly and turning it until the ring falls into its detent position.



15. Turn off the product pump.

16. Close the tank valve by turning the handle 90° from its hose line.



FOAM MARKER

- ⚠ **CAUTION: Do not attempt to operate this machine without covers in place.**
- ⚠ **CAUTION: Never leave the machine running unattended.**
- ⚠ **CAUTION: Never allow children to operate this machine.**
- ⚠ **CAUTION: Wear safety goggles and all proper clothing when operating, servicing, or refilling this machine.**
- ⚠ **CAUTION: Chemical mist or liquid can cause permanent eye, skin, and lung damage or death.**
- ⚠ **CAUTION: Always read and follow manufacturer recommendations when handling any chemical.**
- ⚠ **CAUTION: Never operate this product in or near explosive atmospheres or where aerosol products are being used.**
- ⚠ **CAUTION: Do not use the air compressor to pump anything other than atmospheric air.**
- ⚠ **CAUTION: Do not pump combustible liquids or vapors with this product.**
- ⚠ **CAUTION: Do not use this machine in or near an area where flammable, explosive liquids, or vapors may exist.**
- ⚠ **CAUTION: Do not use this product near flames.**
- ⚠ **IMPORTANT: Inspect the machine for damage after use.**

Compressor Check

After checking all wiring for accuracy, flip the switch to its “On” position and check that air is flowing out of the compressor.

Mixing Foam

Foam mixing takes some experience. Different water sources may require different amounts of chemical concentrate to obtain the desired foam density. Water hardness, pH, and impurities will all affect the amount of chemical concentrate required for a consistent, long-lasting foam.

Different conditions may require different mixing ratios to produce desirable results. It is worthwhile to determine the proper foam to water mixing ratios for your water source with the initial filling. Doing so will save time in the future and aid in consistent foam quality.

If hard water is a problem, commercial softening agents are available. You can make your own softening agent by dissolving a commercial water softening powder (available at most major household product retailers) in hot water and adding a portion of this mixture to your tank each time you fill it. Experimentation will reveal the correct amount to use. A good starting point is 1-1/2 ounces of softener per gallon of water.

Mix ratios for foam concentrates advertised (such as 80:1 or 160:1) must be adjusted for use with your water. Such ratios are only a guideline.

Heat, humidity, wind, and crop cover will also affect the life and usability of foam. Using a good quality marking agent such as GOODMARK may be very important.

From GOODMARK:

Premium life, “hot weather” foam concentrate, up to one hour life in cooler weather, 20-40 minutes in hot weather, good hard water tolerance.

Filling the Foam Tank

1. BE SURE THE POWER UNIT IS TURNED OFF. Remove the cap from the top of the foam tank.
2. Starting with a small amount of water (2 gallons), mix the foam concentrate according to its label's directions.
 - a. If considerably more concentrate is needed above the manufacturer's suggested ratio (usually 2-5 ounces per gallon) to produce good foam, use of a softener or soft water may be required.
 - b. If the foam is too stiff (dry), it may surge out at irregular intervals. Under this condition, water should be added until the foam becomes softer.

3. To ensure proper mixing of foam concentrate and water, you may find it necessary to partially fill the foam tank, add the foam concentrate, then completely fill the foam tank.
4. Replace the cap at the top of the foam tank.

Flow Control Valve & Tubing Connections

The flow control valve regulates the amount of foam solution flowing to the foam-heads. To increase liquid flow, turn the adjusting knob counterclockwise. This valve has been factory preset at 1/2 a turn open. This setting provides for a moderate foam output.

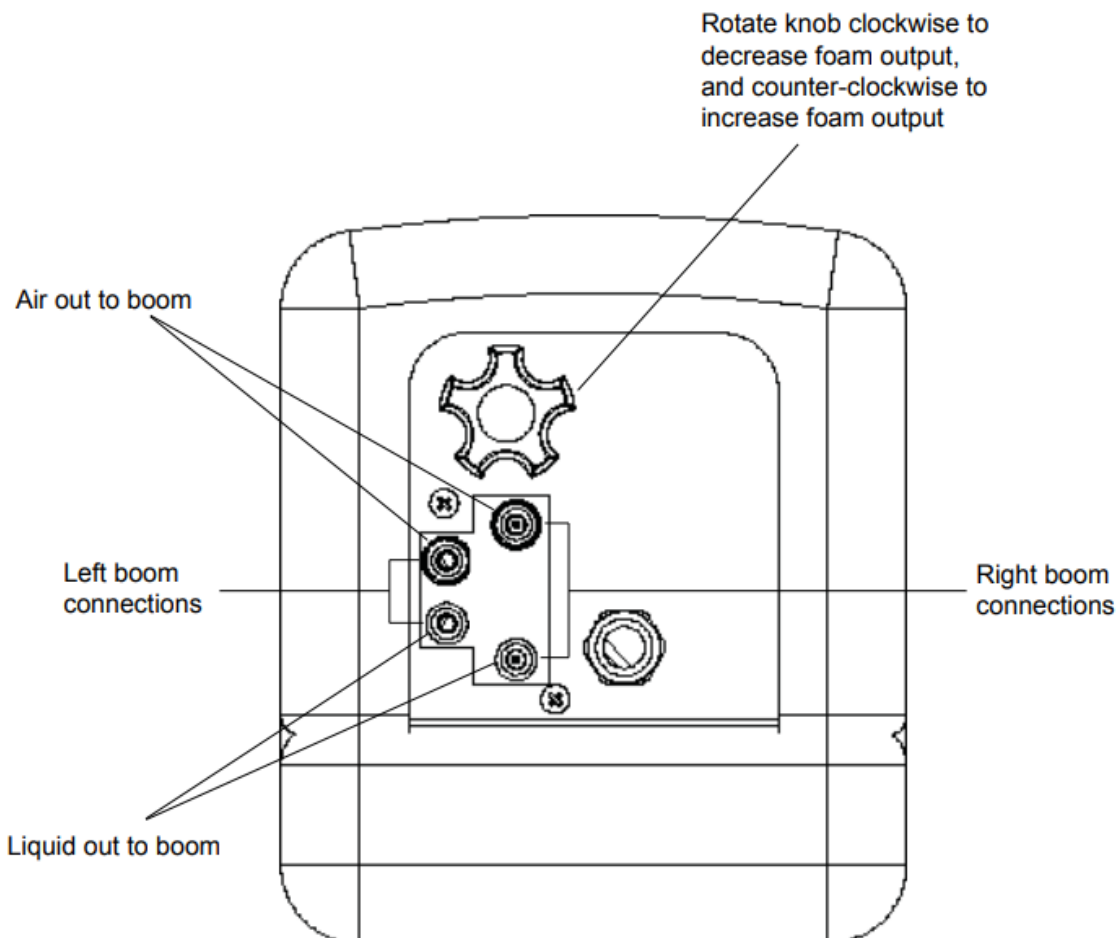

LUBRICATION & MAINTENANCE

Understand all service procedures before doing work.

Perform all service at the interval indicated in this Manual.

Lubricating and Maintaining the Machine Safely

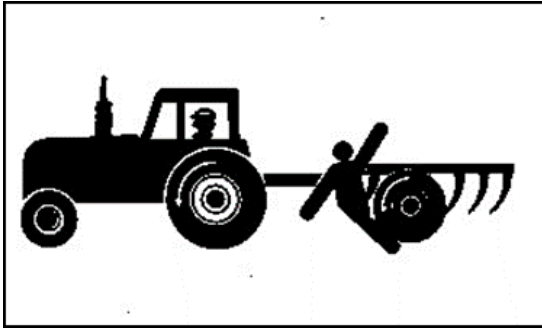

⚠ CAUTION: To help prevent serious injury or death to you or others caused by unexpected movement, be sure to service machine on a level surface.

If the machine is connected to a tractor, engage the tractor's parking brake, place the tractor's transmission in PARK, shut off the engine, and remove its key. If the machine is detached from the tractor, support all machine elements and use safety stands to prevent movement.

- ⚠ CAUTION:** Keep the service area clean and dry.
- ⚠ CAUTION:** Keep hands, feet, and clothing from power-driven parts.
- ⚠ CAUTION:** Lower equipment to the ground.
- ⚠ CAUTION:** Disengage and unload or disperse all power.
- ⚠ CAUTION:** Relieve hydraulic pressure before servicing the equipment or disconnecting from the tractor.

⚠ CAUTION: Disconnect wiring harness from the tractor before servicing electrical system components or welding on machine.

⚠ CAUTION: Securely support all machine elements that must be raised for service work. Use tools, jacks, and hoists of sufficient capacity for the job.

⚠ CAUTION: Avoid pinch points.

⚠ CAUTION: Clear the area of bystanders when adjusting, filling, servicing, or repairing the equipment.

⚠ CAUTION: Wear appropriate PPE for the area of the machine you are working on.

⚠ IMPORTANT: Use adequate lighting for the job.

⚠ IMPORTANT: Keep all parts in good condition and properly installed. Fix damaged parts immediately.

⚠ IMPORTANT: Replace worn and broken parts.

⚠ IMPORTANT: Remove any buildup of grease, oil, or debris.

⚠ IMPORTANT: Remove paint and any residue from solvents before welding or heating.

Lubricant Storage

Equipment can operate at top efficiency only when clean lubricants are used.

Use clean containers to handle all lubricants.

Whenever possible, store lubricants and containers in an area protected from dust, moisture, and other contamination. Store containers on their side to avoid water and dirt accumulation.

Make certain all containers are properly marked to identify their contents.

Properly dispose of all old containers and any residual lubricant they may contain.

Grease

Use an SAE multi-purpose high-temperature grease with extreme-pressure (EP) performance. An SAE multi-purpose lithium base grease is also acceptable.

Use a handheld grease gun.

Clean fittings before greasing.

If a fitting will not take grease, remove and clean it thoroughly. Clean and lubricate the passageway. Replace the fitting if necessary.

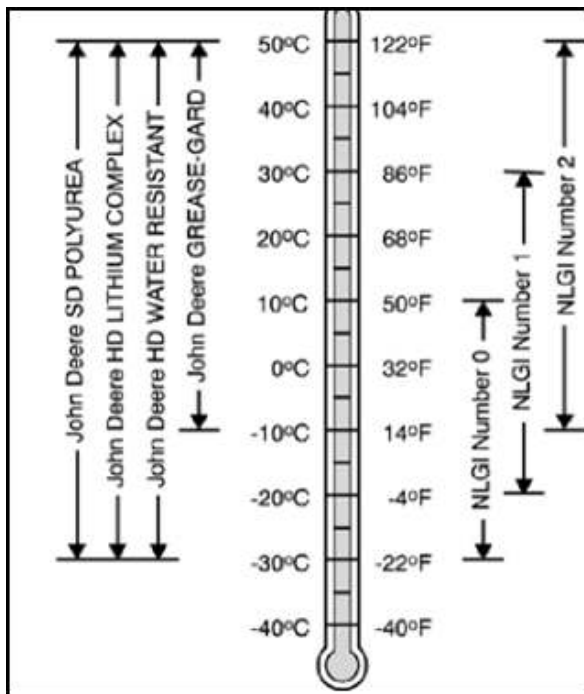

Greases for Air Temperature Ranges

Use grease based on NLGI consistency numbers and the expected air temperature range during the service interval.

IMPORTANT: Some types of grease thickeners are not compatible with others. Consult your grease supplier before mixing different types of grease.

Alternative and Synthetic Lubricants

Conditions in certain geographical areas may require lubricant recommendations different from those printed in this Manual. Synthetic lubricants may be used if they meet the performance requirements as shown in this Manual.

The temperature limits and service intervals shown in this Manual apply to both conventional and synthetic lubricants.

Re-refined base stock products may be used if the finished lubricant meets the performance requirements.

Frame Lubrication

- Grease the wing pivots.

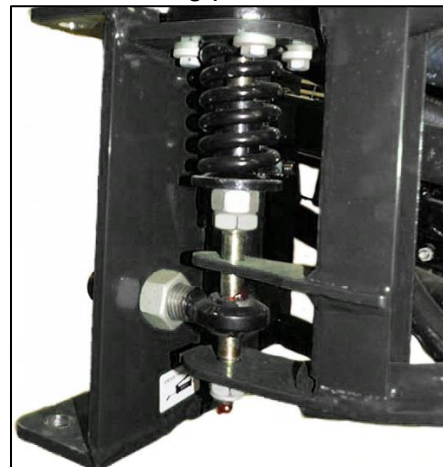

- Grease the Breakaway Clutch.



Pump Maintenance and Service

Filter

The filter location varies by operating system. There may be more than one filter. Follow the procedure below for each filter.



▲ IMPORTANT: Loosen and tighten the filter bodies by hand. Do not use a wrench as this could damage the filter body.

At the start of each day before the water and chemicals have been added, the screens should be checked and cleaned.

1. Close the tank valve and agitation valve.



2. Place a pail under the filter. Remove the drain plug(s) and allow all liquid to drain.



3. Turn the filter body to remove it.

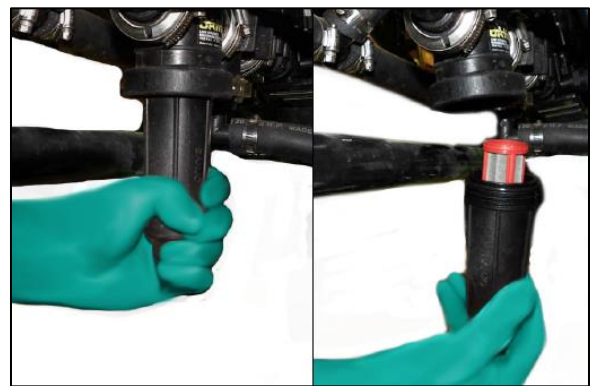

4. Remove the screens and inspect them for dirt or damage.



5. Clean the screens using clean fresh water.
6. Inspect the screens for holes or tears. If any screen is damaged, replace it.

7. Place the screens back into their filter body or bodies.



8. Install the screens and bodies to the filter heads and tighten them by hand. **Do not over-tighten and crack the filter head.**

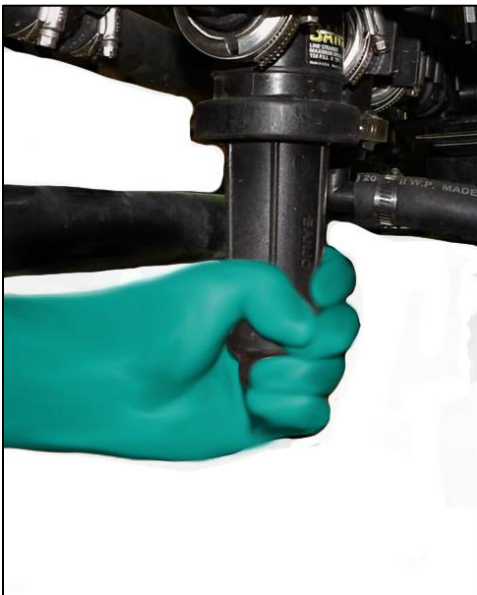

9. Reinstall the drain plug(s).

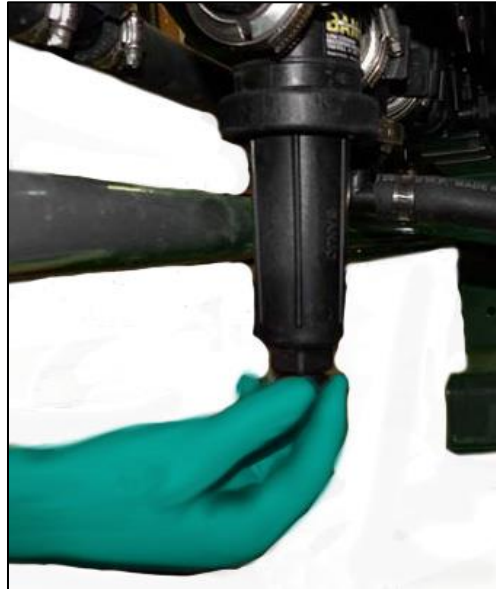

⚠ **NOTE:** Remove drain plugs and drain screens before storage to avoid freezing.

Boom Maintenance and Service

Nozzles

Clean nozzles weekly, before changing chemicals and before calibrating.



Single Spray Nozzle

1. Remove nozzle housing and remove nozzle tip.
2. Clean nozzle tip with clean water.
3. Reinstall nozzle tip.
4. Install nozzle housing and hand tighten.

Wing Bumpers



1. Inspect all wing bumpers for wear and damage.
2. Replace bumpers when they become worn or damaged.
 - a. Remove both bolts.
 - b. Remove the damaged bumper.
 - c. Install the new bumper.
 - d. Replace and tighten the bolts.

Boom Clamps

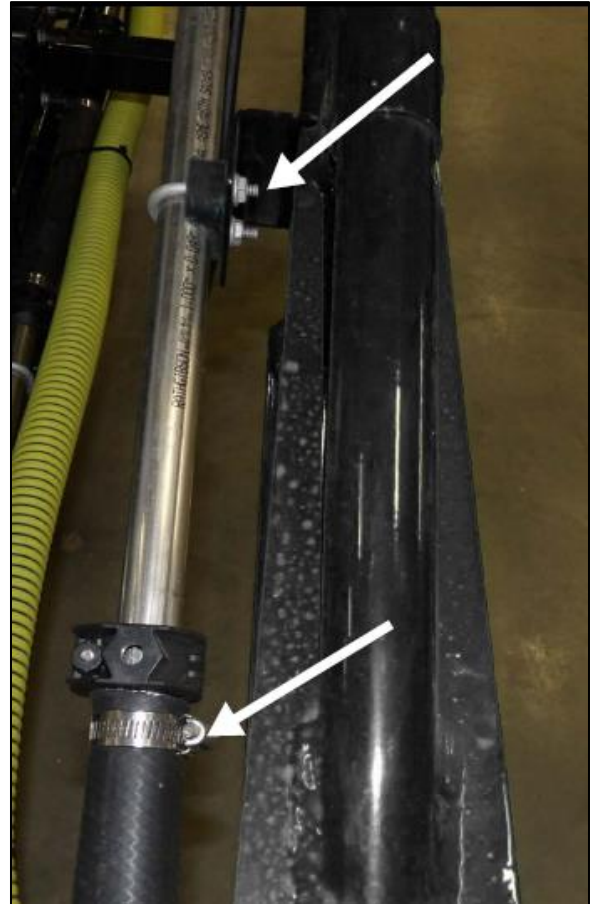

Tighten hose clamps and wet boom clamps monthly.

Gas Shock Replacement

The gas shocks between the wing sections are designed to limit movement of the wing section when folded or unfolded.

When folding or unfolding a flip wing section, you should feel the gas shock pull or snap the section into place. The flip wing section should be stable in the field or transport position. If not, replace the gas shock.

When unfolding or folding the main wing section, you should feel resistance, and the wing should be stable in the field position. If the main wing wobbles, breaks position easily, or slams hard into position, it may be necessary to replace the gas shock.

To replace a gas shock:

1. Remove the nut holding the shock to the frame.
2. Repeat on other end of the shock.
3. Install new gas shock and replace the nut.
4. Test operation.



Figure 18: Gas shock rod-end mounting

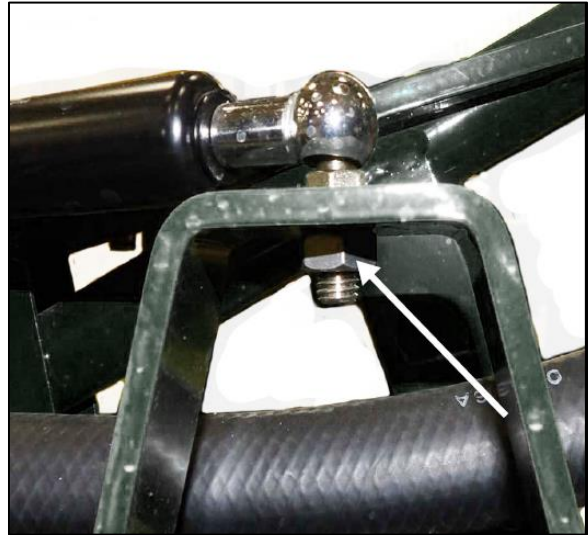

Figure 19: Gas shock base-end mounting

Tank Maintenance and Service

- ⚠ **CAUTION:** Know your working location and how to seek medical attention in an emergency.
- ⚠ **CAUTION:** Never put your head or body into the tank.

Tank Drain Procedure

Follow this procedure to completely drain the tank.

1. Spray as much liquid through the booms as possible.
2. Place a pail under the tank valve.
3. Close the tank valve by turning the valve handle 90° from its hose line.



4. Disconnect the hose from the outlet end of the tank valve and allow the hose to completely drain into the pail.
 - a. Loosen the clamp.
 - b. Carefully remove the hose from the fitting.
 - c. Drain the hose into the pail.



5. Slowly open the tank valve and allow the tank to completely drain.

6. Once draining is complete, close the tank valve, reconnect the hose to the outlet end of the tank valve.
7. Tighten the clamp.

Tank Straps

Tighten the bolt on the strap buckles until the straps have just started to depress the top of the tank. The buckles do not have to be tight against the frame.



Spray Wand Maintenance

Clean the Nozzle

If the spray nozzle becomes clogged, unscrew the nozzle tip and clean it with clean, fresh water.



Do not blow into the nozzle or poke wires into the tip to clear clogged holes. Replace the nozzle tip if it is damaged.

Foam Row Marker Maintenance

- ⚠ All electrical components generate heat. To avoid serious burns, never touch internal components immediately after use.
- ⚠ The air compressor in this unit may be thermally protected and may automatically restart when the protector resets. Always disconnect the power source before servicing.
- ⚠ Wear goggles and all protective clothing when operating, servicing, or refilling this machine. Always read and follow manufacturer recommendations when handling any chemical.
- ⚠ Do not remove covers or attempt repairs while connected to electrical source.
- ⚠ Disassembly or attempted repairs, if accomplished incorrectly, can create hazards. Only qualified personnel should perform repair service.

allowed to freeze, several components may be damaged.

Foamheads and Screen/Strainer

The foamheads have been designed so that the elements inside may be cleaned as necessary. Remove the foamheads from the boom and rinse thoroughly with hot water.

The screen/strainer located in the tank should be checked occasionally to ensure sufficient liquid flow to the foamhead assemblies.

Tank and Hoses

At the end of the season, flush the tank with warm water. Check the air- and liquid-lines for holes and replace as required. Be sure to flush, then drain, all liquid from the system prior to storage in freezing temperatures.

- ⚠ **IMPORTANT:** The liquid lines and tank must be drained completely prior to storage. If liquid in this system is



Cleaning

Daily

At the end of the working day, clean the system using this procedure:

1. After the chemical solution has been completely sprayed out through the booms, add 20 gallons (75 liters) clear water to the tank.
2. Run the agitation pump for 5 minutes.
3. Spray the rinse lightly over previously sprayed crop.
4. Clean the screen and nozzles.
5. Drain the tank and let it dry.

To Remove Salt and Amines Formations

Perform this cleaning cycle when changing chemicals and/or annually.

1. Follow the procedure for [daily cleaning](#).
2. Remove all screens and nozzles and wash them separately.
3. Add 50 gallons (200 liters) of clean water to the tank.
4. Add 1/2 gallon (2 liters) of household ammonia to the tank. (1-part ammonia to 100 parts water).
5. Run the agitation pump for 5 minutes.
6. Spray half of the solution out of the booms.
7. Let the balance sit for a minimum of 8 hours; overnight is best.
8. Run the agitation pump for 10 minutes.
9. Spray solutions out of booms on the appropriate crop.
10. Rinse the system thoroughly with clean water and flush out the booms.
11. Drain the entire system and let it dry.

To Remove Esters of 2, 4-D and MCPA Formations

Perform this cleaning cycle when changing chemicals or annually:

1. Complete the [daily cleaning](#).
2. Remove the nozzles and screens and wash them separately.
3. Add 50 gallons (200 liters) of clean water to the- main tank.
4. Add dishwasher detergent to the tank (2 lbs. detergent to 50 gallons of water (1 kg:300 L)).
5. Run the agitation pump for 10 minutes.
6. Spray the solution out of the booms on appropriate crops and drain thoroughly.
7. Add 50 gal (200 L) of clean water to the tank.
8. Add 1/2 gal. (2 L) of household ammonia to the tank (1-part ammonia to 100 parts water).
9. Run the agitation pump for 10 minutes.
10. Spray half of the solution out of the booms.
11. Let the balance sit for a minimum of 8 hours; overnight is best.
12. Run the agitation pump for 10 minutes.
13. Spray out of the booms on the appropriate crop.
14. Rinse the system thoroughly with clean water and flush out the booms.
15. Drain the entire system and let it dry.

SERVICE**Practice Safe Maintenance**

Understand all service procedures before doing work. Keep the area clean and dry.

Never lubricate, service, or adjust the machine while it is moving. Keep hands, feet, and clothing away from power-driven parts. Disengage all power and operate controls to relieve pressure. Lower equipment to the ground. Stop the engine. Remove the key. Allow the machine to cool. Securely support any machine elements that must be raised for service work.

Keep all parts in good condition and properly installed. Fix any damage immediately. Replace worn or broken parts. Remove any buildup of grease, oil, or debris.

On self-propelled equipment, disconnect the battery ground cable (-) before making adjustments on any electrical systems or welding on the machine.

On towed implements, disconnect its wiring harnesses from the tractor before servicing any electrical system components or welding on the machine.

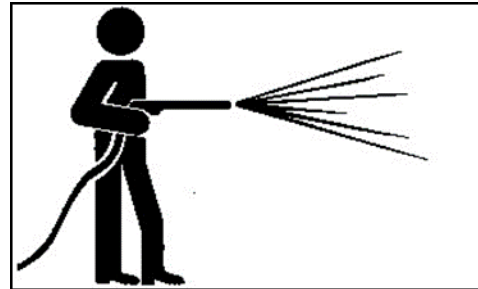
Work in a Clean Area

Before starting a job:

- Clean the work area and the machine.
- Make sure you have all the necessary tools to do your job.
- Have the right parts on-hand.
- Read all instructions thoroughly; do not attempt shortcuts.

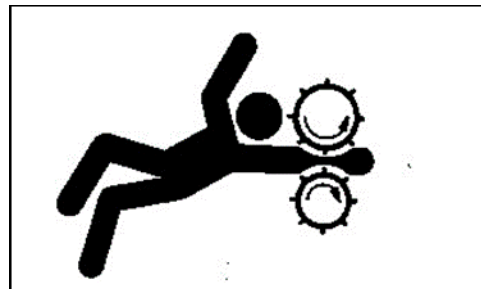
Service Machines Safely

Tie long hair behind your head. Do not wear a necktie, scarf, loose clothing, or necklace when you work near machine tools or moving parts. If these items were to get caught, severe injury could result.

Remove rings and other jewelry to prevent electrical shorts and entanglement in moving parts.

Support the Machine Properly



Always lower the attachment or implement to the ground before you work on the machine. If the work requires that the machine or attachment be lifted, provide secure support for them. If left in a raised position, hydraulically supported devices can settle or leak down.

Do not support the machine on cinder blocks, hollow tiles, or props that may crumble under continuous load. Do not work under a machine that is supported solely by a jack. Follow the recommended procedures in this Manual.

When implements or attachments are used with a machine, always follow safety precautions listed in the implement or attachment's Operator's Manual.

Avoid High-Pressure Fluids



Inspect hydraulic hoses periodically – at least once per year – for leakage, kinking, cuts, cracks, abrasion, blisters, corrosion, exposed wire braids, or any other signs of wear or damage.

Replace worn or damaged hose assemblies immediately with Fast Ag Solutions approved replacement parts.

Escaping fluid under pressure can penetrate the skin causing serious injury. Avoid the hazard by relieving pressure before disconnecting hydraulic or other lines. Tighten all connections before applying pressure.

Search for leaks with a piece of cardboard. Protect hands and body from high-pressure fluids.

If an accident occurs, see a doctor immediately. Any fluid injected into the skin must be surgically removed within a few hours or gangrene may result. Doctors unfamiliar with this type of injury should reference a knowledgeable medical source.

Preventing Hydraulic System Contamination

IMPORTANT: Cleanliness is very important when working on a hydraulic system. Prevent contamination by assembling cylinders, hoses, couplers, and valves in a clean area of the shop.

Leave protective caps on fluid openings until you are ready to make a connection. When charging the system, use a tractor or other source that contains clean oil free of abrasive materials.

Keep couplers clean. Abrasive particles, like sand or metal fragments, can damage seals, barrels, and pistons causing internal leakage.

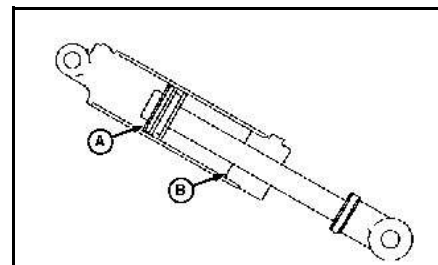

- A. Piston
- B. Rod Guide or Gland

⚠ IMPORTANT: To help keep couplers clean, always place them in a storage position when they are not attached to the tractor.

⚠ IMPORTANT: To prevent contaminants from entering the hydraulic system, filters must be installed at the tip of a supply hose. Additional filters are not recommended as they will restrict oil flow and adversely affect cylinder actuation time due to pressure drop.

Without a filter, large dirt particles can enter the cylinder and settle against the top side of piston (A) where they can cut the piston seal as the cylinder retracts.

Replace Hydraulic Hoses

⚠ WARNING: Avoid hazards due to escaping fluid under pressure. See [Avoid High-Pressure Fluids](#).

Hydraulic hoses between the lift cylinders and hydraulic lock-up valve should be inspected frequently for leakage, kinking, cuts, cracks, abrasion, blisters, corrosion, exposed wire braids, or any other signs of wear or damage.

Worn or damaged hose assemblies can fail during use and should be replaced immediately.

See your Fast Ag Solutions dealer for replacement hoses.

⚠ CAUTION: If an incorrectly rated hose is used, machine damage, injury, or death could occur.

If hoses are to be fabricated, ensure that the hoses are rated at no less than 82,737 kPa (827 bar) (12,000 psi) burst pressure according to SAE Standard J517, 100R17 hose specification.

Incorrect hose length or routing can increase the chance of hose wear or damage. Use the

old hose as a guide for length and hose routing.

Incorrect fittings can damage mating parts or cause leaks. Make sure to use steel fittings approved for use by the hose's manufacturer. Use the correct size and thread.

Make sure hydraulic hoses and harnesses do not interfere with moving parts. Relocate hoses and harnesses and retain them with clamps.

Tightening Hardware

Tighten all bolts to torques specified in [TIGHTENING HARDWARE](#) section unless otherwise noted.

Check tightness of hardware periodically.

Pressure Gauge Replacement

Replace the pressure gauge and or the pressure line if either is damaged or malfunctioning.

To replace the gauge:

1. Relieve pressure to the booms.
2. Uninstall the pressure gauge by loosening the mounting nut. (1)
3. Replace gauge and tighten nut.

To replace the pressure line:

1. Relieve pressure to the booms.
2. Disconnect the pressure line (2) from the gauge.
3. Disconnect the pressure line from the section valves. (3)
4. Replace the line and be sure to route it through the support bracket. (4)
5. Reconnect the line to the gauge.
6. Reconnect the line to the section valves.
7. Test operation.

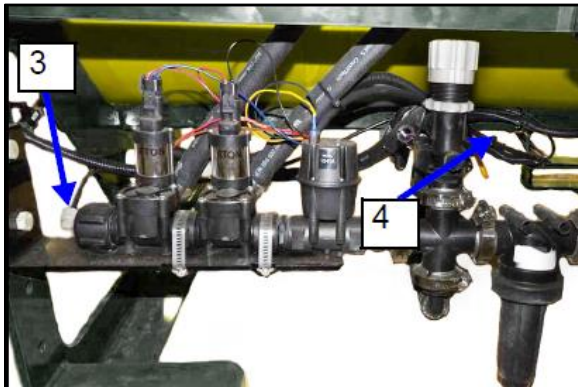
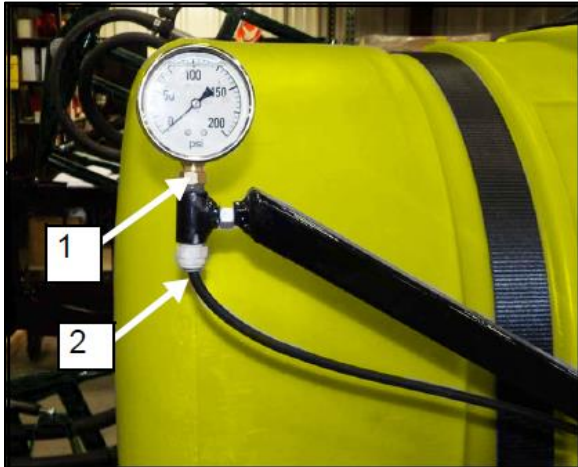

Taillight Replacement

Disconnect the taillight wiring harness (1).

To replace the bulb:

1. Twist socket (2) to remove light.
2. Replace bulb.
3. Insert socket into light assembly and twist to lock.
4. Connect taillight wiring harness (1).

To replace the light assembly:

1. Remove broken light socket (2).
2. Remove light assembly bolts (3).
3. Replace light assembly.
4. Install bolts (3).
5. Install light socket (2).
6. Connect taillight wiring harness (1).

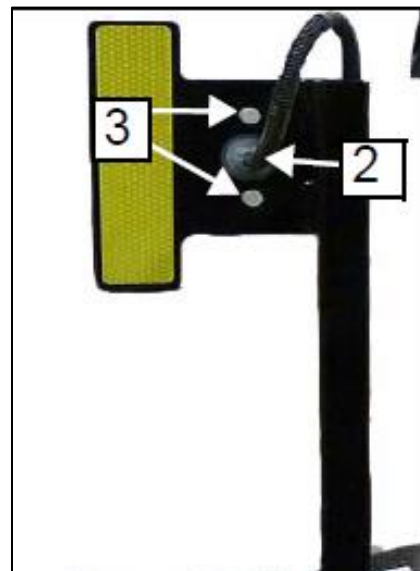

Spray Wand Service

Hose Replacement

Replace the hose if it is cut, worn, or damaged.

1. Close the tank valve, agitation valve, and spray wand valve.



2. Disconnect the hose from the reel.
 - a. Loosen the clamp at the spray wand.
 - b. Remove the hose from its fitting.
 - c. Remove the clamp from the old hose.



3. Place the end of the hose in a pail to allow fluid to drain.
4. Remove the hose from the hose reel.

- a. Loosen the clamp from the fitting by the hose reel handle.
- b. Slide the hose off its fitting.
- c. Remove the clamp.
- d. Loosen the support clamp and slide the hose through.
- e. Unwind the hose from its reel.

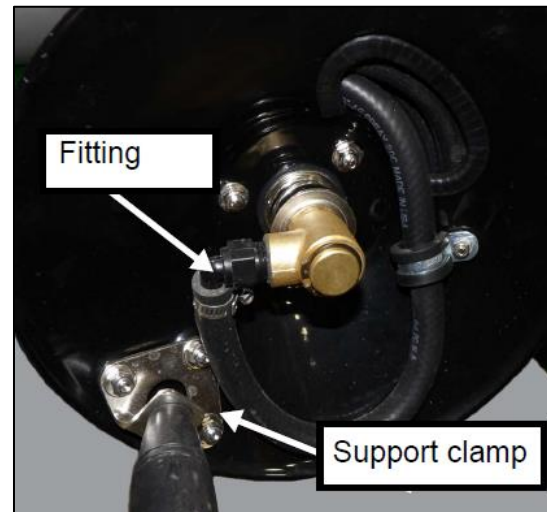

5. Install the new hose.
 - a. Start the hose from the front on the topline of the hose reel.
 - b. Insert the hose through the hole in the hose reel.
 - c. Slide the support clamp and end clamp onto the hose.
 - d. Slide the hose onto the reel fitting.
 - e. Tighten clamp.
 - f. Tighten fitting.
 - g. Install the hose support clamp.
 - h. Wind up the hose leaving enough to reach the spray wand.
 - i. Slide the clamp onto the hose.
 - j. Slide the hose onto the spray wand fitting.
 - k. Tighten clamp.
 - l. Turn on the spray wand and check for leaks.
 - m. Tighten clamps if needed to stop leaks.

Hose-Tank Connection Replacement

Replace the hose connection to the tank:

1. Close the tank valve, agitation pump valve and spray wand valve.

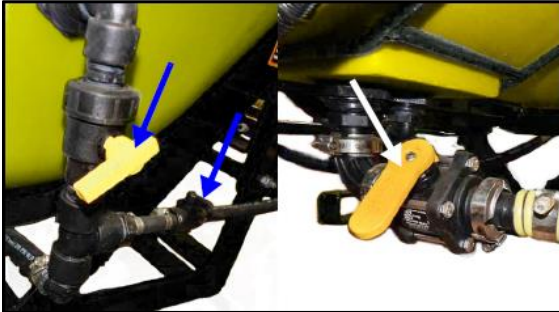

2. Disconnect the hose:
 - a. Loosen the clamp holding the hose to the fitting.
 - b. Slide the hose off the fitting.
 - c. Remove the clamp from hose.

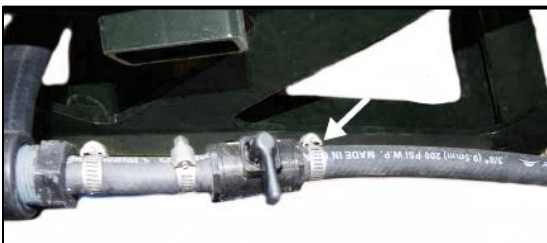

3. Disconnect the hose from its valve:
 - a. Loosen the clamp near the spray wand handle.
 - b. Slide the hose from the fitting.
 - c. Remove the clamp from the hose.
4. Install the new hose:
 - a. Slide the clamps on the new hose.
 - b. Slide the hose onto its fittings.
 - c. Tighten all the clamps and fittings.
 - d. Turn on the sprayer and check for leaks.
 - e. Tighten clamps to stop leaks.

PREPARING FOR STORAGE

⚠ CAUTION: Store the unit in an area away from human activity. Do not permit children to play on or around the stored Sprayer.

At the end of the season, thoroughly inspect and prepare the Sprayer for storage. Repair or replace any worn or damaged components to prevent any unnecessary downtime at the beginning of next season.

⚠ IMPORTANT: The tank is made from polyethylene. Do not use or store petroleum products on or in the tank. They will be absorbed into and soften the plastic.

1. Thoroughly wash the machine to remove all dirt, mud, debris, and residue to protect against corrosion.
2. Empty any remaining liquid from tank. Flush the entire system with clean freshwater.
3. Drain all fluids out of the system. See [Tank Drain Procedure](#).
4. Lubricate all grease points. Make sure all grease cavities have been filled with grease to remove any water residue from washing. See [LUBRICATION & MAINTENANCE](#).
5. Inspect all hydraulic hoses, couplers, and fittings. Tighten any loose fittings. Replace any hose that is damaged or is separating from the crimped end of a fitting.
6. Inspect all liquid lines and connections. Tighten any loose fittings. Replace any line that is cut, nicked, or abraded.
7. Touch up all paint nicks and scratches to prevent rusting.
8. Fold the inner and outer wings to the transport configuration.
9. Move the machine to a storage location that is dry, level, and free of debris.

10. Avoid leaving the Sprayer in direct sunlight (ultraviolet radiation) for extended periods of time.
11. Unhook Sprayer from tractor.

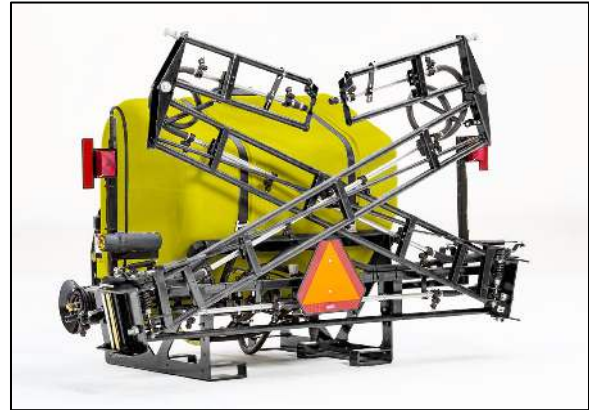

Winterization



1. Remove the line caps at the end of the stainless-steel wet booms.
2. Connect an air compressor and blow the lines out until no water remains.
3. Replace the end caps.
4. Add approximately 38 L (10 gal) of RV antifreeze per 3 m (10 ft.) of toolbar.
5. Flush the system, then pump through screens, valves, nozzles, check valves, and orifices/tips.

For the Foam Row Marker

1. Completely flush the foam tank with warm water.
2. Turn on the machine and allow it to operate until no foam is generated.
3. Add anti-freezing solution such as windshield washer solvent to tank.

4. Run the machine until anti-freezing solution reaches the foamheads.
5. Check the air- and liquid-lines for holes and replace as required. Be sure to flush, then drain, all liquid from the system prior to storage in freezing temperatures.

Removing from Storage

1. Clear the area of bystanders, especially small children, and remove foreign objects from the machine and working area.
2. Attach the tractor to the Sprayer.
3. Check:
 - a. Attach and secure all liquid lines.
 - b. Row Units and Nozzles.
 - c. All hardware. Tighten as required.
 - d. Tire pressure.
 - e. All hydraulic lines, fittings, and connections. Tighten as required.
 - f. The tanks for cracks or damage.
 - g. Tank straps and hold-down hardware.
4. Lubricate all grease fittings. See [LUBRICATION & MAINTENANCE](#).
5. Replace any defective parts.
6. Drain the tank. See [Tank Drain Procedure](#).
7. Add a small amount of liquid to the tank. Check that liquid comes out of each nozzle/injector.
8. Calibrate the pump, nozzles, and Sprayer before using. See [SPRAYER CALIBRATION](#).
9. Follow the [Pre-Operation Checklist](#) before using.

TROUBLESHOOTING

General

Problem	Cause	Solution
Sprayer pressure too high	Return hose plugged.	Clean or replace hose.
	Wrong agitation value setting.	Open agitation valve slightly until pressure goes to required range.
Sprayer pressure too low	Return hose plugged.	Clean or replace hose.
	Wrong agitation valve setting.	Close agitation valve slightly until pressure goes to required range.
High spray drift	Boom set too high.	Lower boom.
	Too windy.	Wait for wind to calm.
Boom is bouncing	Traveling too fast.	Slow down.
Main wing wobbles	Clutch too loose.	Tighten clutch bolts.
	Gas shock malfunctioning.	Replace gas shock.
Main wing slams hard into folded or unfolded position.	Gas shock malfunctioning.	Replace gas shock.
Flip wing bounces in transport or field position.	Gas shock malfunctioning.	Replace gas shock.

Controller

Problem	Action
Valve fails to open	Check if the coil is burnt out
	Remove the coil and check if the plunger is stuck
	Check if the seat in the plunger is bulged or swollen. If so, use a fine sandpaper and sand the seat down so that it is flat with the metal.
	Check the channel under and to the plunger for blockage.
	Check the control box and wiring harness for broken wires, bad switches, and blown fuses
Valve fails to shut off	Remove the coil and check if the plunger is stuck.
	Disassemble the valve and check if the spring is broken
	Check for proper electrical connections

Foam Maker

If you do not get foam:

1. Be sure the air line and liquid lines do not have a hole in them or are not pinched, remove air and liquid tubing at each foamhead, and check for flow.
2. Be sure you have enough foam concentrate in the tank. Very hard water may require a great amount of concentrate to produce good foam. Not having enough foam concentrate in the tank may make good foam but may not make enough foam. Be sure to use a high-quality concentrate such as GOODMARK.
3. Check and clean the screen-strainer located in the tank.
4. Be sure the flow control valve is open.
5. If the foam mixture in the tank is several days old, it is possible that the solution is no longer able to foam or produces little foam. Drain tank, rinse, and start with a fresh solution.
6. Check the battery connections to be certain that the positive and negative terminals are not reversed.

Problem	Solution
Not enough foam	Add more foam concentrate to tank
	Check for holes in airline
	Check for pinched air or liquid lines
	Clean screen-strainer/foamhead
	Adjust liquid flow control valve
Wet foam	Add more foam concentrate to tank
	Clean screen-strainer/foamhead
	Reduce liquid flow
Foam is surging	Use less concentrate
Foam does not last on the ground	Add more foam concentrate to tank
	Use a high-quality foam concentrate like GOODMARK
	Use collector heads
Blowing foam in windy weather	Use less concentrate to make wetter foam
	Add more water to foam solution
	Increase liquid flow

TIGHTENING HARDWARE

Check the tightness of ALL BOLTS, U-BOLTS, and CAP SCREWS after the first 10-15 hours of operation and again at end of the first week (50 hours) of operation. Tighten all bolts to torques specified unless otherwise noted. Check tightness of hardware periodically.

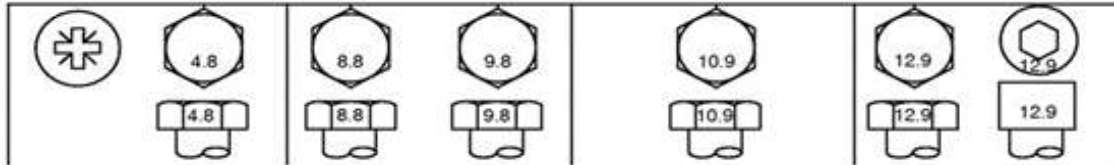

Figure 20: Common metric bolt grade markings

Metric Bolt and Screw Torque Values

Screw Size	Class 4.8				Class 8.8 or 9.8				Class 10.9				Class 12.9			
	Lubricated ³		Dry ⁴		Lubricated ³		Dry ⁴		Lubricated ³		Dry ⁴		Lubricated ³		Dry ⁴	
	N-m	lb.-in.	N-m	lb.-in.	N-m	lb.-in.	N-m	lb.-in.	N-m	lb.-in.	N-m	lb.-in.	N-m	lb.-in.	N-m	lb.-in.
M6	4.7	42	6	53	8.9	79	11.3	100	13	115	16.5	146	15.5	137	19.5	172
									N-m	lb.-ft.	N-m	lb.-ft.	N-m	lb.-ft.	N-m	lb.-ft.
M8	11.5	102	14.5	128	22	194	27.5	243	32	23.5	40	29.5	37	27.5	47	35
			N-m	lb.-ft.	N-m	lb.-ft.	N-m	lb.-ft.								
M10	23	204	29	21	43	32	55	40	63	46	80	59	75	55	95	70
	N-m	lb.-ft.														
M12	40	29.5	50	37	75	55	95	70	110	80	140	105	130	95	165	120
M14	63	46	80	59	120	88	150	110	175	130	220	165	205	150	260	190
M16	100	74	125	92	190	140	240	175	275	200	350	255	320	235	400	300
M18	135	100	170	125	265	195	330	245	375	275	475	350	440	325	560	410
M20	190	140	245	180	375	275	475	350	530	390	675	500	625	460	790	580
M22	265	195	330	245	510	375	650	480	725	535	920	680	850	625	1080	800
M24	330	245	425	315	650	480	820	600	920	680	1150	850	1080	800	1350	1000
M27	490	360	625	460	950	700	1200	885	1350	1000	1700	1250	1580	1160	2000	1475
M30	660	490	850	625	1290	950	1630	1200	1850	1350	2300	1700	2140	1580	2700	2000
M33	900	665	1150	850	1750	1300	2200	1625	2500	1850	3150	2325	2900	2150	3700	2730
M36	1150	850	1450	1075	2250	1650	2850	2100	3200	2350	4050	3000	3750	2770	4750	3500

Torque values listed are for general use only, based on the strength of the bolt or screw. DO NOT use these values if a different torque value or tightening procedure is given for a specific application. For stainless steel fasteners or for nuts on U-bolts, see the tightening instructions for the specific application. Tighten plastic insert or crimped steel type lock nuts by turning the nut to the dry torque shown in the chart, unless different instructions are given for the specific application.

Shear bolts are designed to fail under predetermined loads. Always replace shear bolts with identical property class. Replace fasteners with the same or higher property class. If higher property class fasteners are used, tighten these to the strength of the original. Make sure fastener threads are clean and that you properly start thread engagement. When possible, lubricate plain or zinc plated fasteners other than lock nuts, wheel bolts, or wheel nuts, unless different instructions are given for the specific application.

³ "Lubricated" means coated with a lubricant such as engine oil, fasteners with phosphate and oil coatings, or M20 and larger fasteners with JDM F13C, F13F or F13J zinc flake coating.

⁴ "Dry" means plain or zinc plated without any lubrication, or M6 to M18 fasteners with JDM F13B, F13E or F13H zinc flake coating.

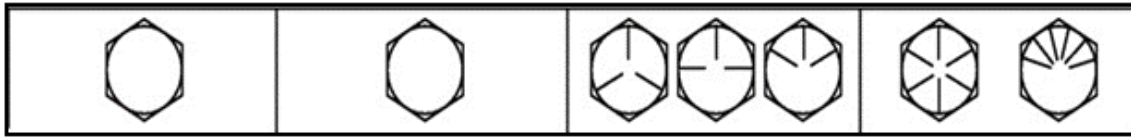

Figure 21: Common imperial bolt grade markings

Unified Inch Bolt and Screw Torque Values

Screw Size	SAE Grade 1				SAE Grade 2 ⁵				SAE Grade 5, 5.1 or 5.2				SAE Grade 8 or 8.2			
	Lubricated ⁶		Dry ⁷		Lubricated ⁶		Dry ⁷		Lubricated ⁶		Dry ⁷		Lubricated ⁶		Dry ⁷	
	N-m	lb.-in.	N-m	lb.-in.	N-m	lb.-in.	N-m	lb.-in.	N-m	lb.-in.	N-m	lb.-in.	N-m	lb.-in.	N-m	lb.-in.
1/4	3.7	33	4.7	42	6	53	7.5	66	9.5	84	12	106	13.5	120	17	150
													N-m	lb.-ft.	N-m	lb.-ft.
5/16	7.7	68	9.8	86	12	106	15.5	137	19.5	172	25	221	28	20.5	35	26
									N-m	lb.-ft.	N-m	lb.-ft.				
3/8	13.5	120	17.5	155	22	194	27	240	35	26	44	32.5	49	36	63	46
			N-m	lb.-ft.	N-m	lb.-ft.	N-m	lb.-ft.								
7/16	22	194	28	20.5	35	26	44	32.5	56	41	70	52	80	59	100	74
	N-m	lb.-ft.														
1/2	34	25	42	31	53	39	67	49	85	63	110	80	120	88	155	115
9/16	48	35.5	60	45	76	56	95	70	125	92	155	115	175	130	220	165
5/8	67	49	85	63	105	77	135	100	170	125	215	160	240	175	305	225
3/4	120	88	150	110	190	140	240	175	300	220	380	280	425	315	540	400
7/8	190	140	240	175	190	140	240	175	490	360	615	455	690	510	870	640
1	285	210	360	265	285	210	360	265	730	540	920	680	1030	760	1300	960
1-1/8	400	300	510	375	400	300	510	375	910	670	1150	850	1450	1075	1850	1350
1-1/4	570	420	725	535	570	420	725	535	1280	945	1630	1200	2050	1500	2600	1920
1-3/8	750	550	950	700	750	550	950	700	1700	1250	2140	1580	2700	2000	3400	2500
1-1/2	990	730	1250	930	990	730	1250	930	2250	1650	2850	2100	3600	2650	4550	3350
Torque values listed are for general use only, based on the strength of the bolt or screw. DO NOT use these values if a different torque value or tightening procedure is given for a specific application. For plastic insert or crimped steel type lock nuts, for stainless steel fasteners, or for nuts on U-bolts, see the tightening instructions for the specific application. Shear bolts are designed to fail under predetermined loads. Always replace shear bolts with identical grade.									Replace fasteners with the same or higher grade. If higher grade fasteners are used, tighten these to the strength of the original. Make sure fastener threads are clean and that you properly start thread engagement. When possible, lubricate plain or zinc plated fasteners other than lock nuts, wheel bolts, or wheel nuts, unless different instructions are given for the specific application.							

⁵ Grade 2 applies for hex cap screws (not hex bolts) up to 6 in. (152 mm) long. Grade 1 applies for hex cap screws over 6 in. (152 mm) long, and for all other types of bolts and screws of any length.

⁶ "Lubricated" means coated with a lubricant such as engine oil, fasteners with phosphate and oil coatings, or 7/8 in. and larger fasteners with JDM F13C, F13F or F13J zinc flake coating.

⁷ "Dry" means plain or zinc plated without any lubrication, or 1/4 to 3/4 in. fasteners with JDM F13B, F13E or F13H zinc flake coating.

Face Seal Fittings Assembly & Installation - All Pressure Applications

Face Seal O-Ring to Stud End Installation

1. Inspect the fitting surfaces. They must be free of dirt and defects.
2. Inspect the O-ring. It must be free of damage and defects.
3. Lubricate the O-rings and install them into the groove using petroleum jelly to hold them in place.
4. Push the O-ring into the groove with petroleum jelly so that the O-ring is not displaced during assembly.
5. Index any angle fittings and tighten by hand, pressing the joint together to ensure that the O-ring remains in place.
6. Tighten the fitting or nut to the torque value shown on the chart per dash size stamped on the fitting. DO NOT allow hoses to twist when tightening fittings.

Face Seal Adjustable Stud End O-Ring Installation

1. Back off the lock nut (jam nut) and washer to fully expose turned down section of the fitting.
2. Install a thimble over the fitting threads to protect the O-ring from nicks.
3. Slide the O-ring over the thimble into the turned down section of the fitting.
4. Remove thimble.

Face Seal Straight Stud End O-Ring Installation

1. Install a thimble over the fitting threads to protect the O-ring from nicks.
2. Slide the O-ring over the thimble into the turned down section of the fitting.
3. Remove thimble.

Fitting Installation

1. Install the fitting by hand until it is snug.
2. Position adjustable fittings by unscrewing the fitting no more than one turn.
3. Apply with an assembly torque per table.

Assembly Torque

1. Use one wrench to hold the connector body and one wrench to tighten the nut.
2. For a hydraulic hose, it may be necessary to use three wrenches to prevent twist: one on the connector body, one on the nut, and one on the body of the hose fitting.

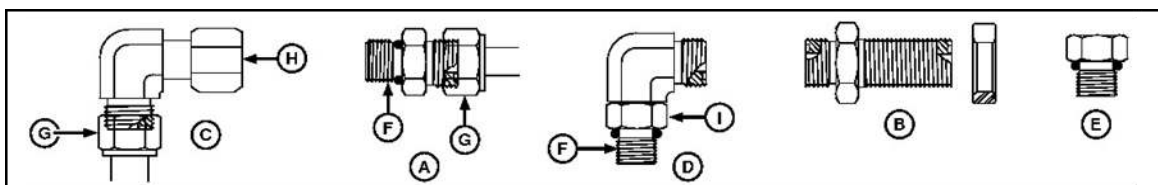

Figure 22: Common hydraulic fitting shapes and components

- | | |
|---|---------------|
| A. Stud Straight and Tube Nut | G. Tube Nut |
| B. Bulkhead Union and Bulkhead Lock Nut | H. Swivel Nut |
| C. 90° Swivel Elbow and Tube Nut | I. Lock Nut |
| D. 90° Adjustable Stud Elbow | |
| E. Port Plug | |
| F. Stud End | |



TIGHTENING HARDWARE

SAE Face Seal and O-Ring Stud End Fitting Torque Chart

SAE Face Seal and O-Ring Stud End Fitting Torque Chart - Standard Pressure-Below 27.6 MPA (4,000 PSI)																	
Nominal Tube OD Hose ID				O-Ring Face Seal/ Tube Swivel Nut				Bulkhead Jam Nut Torque			O-Ring Straight, Adjustable, and External Port Plug Stud Ends ⁸						
Metric Tube OD	Inch Tube OD			Thread Size	Swivel Nut Hex Size	Tube Nut Swivel Nut Torque		Jam Nut Hex Size	Jam Nut Torque		Thread Size	Straight Hex Size ⁹	Adj Lock Nut Hex Size	Steel or Gray Iron Torque		Aluminum or Brass Torque ¹⁰	
	mm	Dash Size	in.			mm	in.		N-m	lb.- ft				N- m	lb.- ft	in.	in.
5	-3	0.188	4.78	—	—	—	—	—	—	—	3/8-24	5/8	9/16	12	9	8	6
6	-4	0.250	6.35	9/16-18	11/16	16	12	13/16	32	24	7/16-20	5/8	5/8	16	12	11	8
8	-5	0.312	7.92	—	—	—	—	—	—	—	1/2-20	3/4	11/16	24	18	16	12
10	-6	0.375	9.53	11/16-16	13/16	24	18	1	42	31	9/16-18	3/4	3/4	37	27	25	18
12	-8	0.500	12.70	13/16-16	15/16	50	37	1-1/8	93	69	3/4-16	7/8	15/16	50	37	33	25
16	-10	0.625	15.88	1-14	1-1/8	69	51	1-5/16	118	87	7/8-14	1-1/16	1-1/16	69	51	46	34
20	-12	0.750	19.05	13/16-12	1-3/8	102	75	1-1/2	175	129	11/16-12	1-1/4	1-3/8	102	75	68	50
22	-14	0.875	22.23	13/16-12	—	102	75	—	175	129	13/16-12	1-3/8	1-1/2	122	90	81	60
25	-16	1.000	25.40	17/16-12	1-5/8	142	105	1-3/4	247	182	15/16-12	1-1/2	1-5/8	142	105	95	70
32	-20	1.25	31.75	1-11/16-12	1-7/8	190	140	2	328	242	1-5/8-12	1-3/4	1-7/8	190	140	127	93
38	-24	1.50	38.10	2-12	2-1/4	217	160	2-3/8	374	276	1-7/8-12	2-1/8	2-1/8	217	160	145	107
50.8	-32	2.000	50.80	—	—	—	—	—	—	—	2-1/2-12	2-3/4	2-3/4	311	229	207	153

⁸ Tolerance is +15%/-20% of mean tightening torque unless otherwise specified.

⁹ The straight hex wrench sizes listed apply to connectors only and may not be the same as the corresponding plug of the same thread size.

¹⁰ These torques were established using steel plated connectors in aluminum and brass.



Fast Ag Solutions
4130 Commerce Boulevard
Windom, MN 56101

1-800-772-9279 Toll Free

1-507-427-3861 Voice

1-507-427-3030 Fax

<https://fastagsolutions.com/>