



## **RH15 / RH18 ROTARY HOE PARTS MANUAL - 2021**







## Limited Warranty

Fast Ag Solutions, LLC (Fast Ag Solutions) warrants to the buyer that the new machinery is free from defects in material and workmanship.

This warranty is only effective as to any new machinery which has not been altered, changed, repaired or treated since its delivery to the buyer, other than by Fast Ag Solutions or its authorized dealers or employees, and does not apply to accessories, attachments, tools or parts, sold or operated with the new machinery, if they have not been manufactured by Fast Ag Solutions.

Fast Ag Solutions shall only be liable for defects in the materials or workmanship attributable to faulty material or bad workmanship that can be proved by the buyer, and specifically excludes liability for repairs arising as a result of normal wear and tear of the new machinery or in any other manner whatsoever, and without limiting the generality of the foregoing, excludes application or installation of parts not completed in accordance with this operator's manual, specifications, or printed instructions.

Written notice shall be given by registered mail, to the Manufacturer within seven (7) days after the defect shall have become apparent or the repairs shall have become necessary, addressed as follows:

Fast Ag Solutions, LLC  
4130 Commerce Boulevard  
Windom, MN 56101

This warranty shall expire one (1) year after the date of delivery of the new machinery.

If these conditions are fulfilled, Fast Ag Solutions shall at its own cost and at its own option either repair or replace any defective parts provided that the buyer shall be responsible for all expenses incurred as a result of repairs, labor, parts, transportation or any other work, unless Fast Ag Solutions has authorized such expenses in advance.

The warranty shall not extend to any repairs, changes, alterations, or replacements made to the new equipment other than by Fast Ag Solutions or its authorized dealers or employees.

This warranty extends only to the original owner of the new equipment.

Rubber parts (including tires, hoses, grommets) are not warranted.

This warranty is limited to the terms stated herein and is in lieu of any other warranties whether express or implied, and without limiting the generality of the foregoing, excluded all warranties, express or implied or conditions whether statutory or otherwise as to quality and fitness for any purpose of the new equipment. the Manufacturer disclaims all liability for incidental or consequential damages.

This Rotary Hoe is subject to design changes and Fast Ag Solutions shall not be required to retrofit or exchange items on previously sold units except at its own option.

Warranty void if not registered.



Fast

RH15 / RH18 Rotary Hoe

Warranty Registration Form & Inspection Report

Warranty Registration

This form must be filled out by the dealer and signed by both the dealer and the customer at the time of delivery.

Customer Name				
Address				
City		State		Zip
Phone				
Dealer Name				
Address				
City		State		Zip
Model Number				
Serial Number				
Delivery Date				

DEALER INSPECTION REPORT

- All Fasteners Tight
- Wheel Bolts Torqued
- Hydraulic Hoses and Fittings Free and Tight
- Fertilizer Hoses and Fittings Free and Tight
- Wheel Drive Turns Freely
- Lubricate Machine
- Check Tire Pressure
- Frame and Wings Level
- Monitors and Controllers Function
- Wiring Harness Connected

SAFETY

- Safety Chain Installed
- All Guards Installed
- All Safety Signs Installed
- Reflectors, SMV and Lights Clean
- Review Operating and Safety Instructions

I have thoroughly instructed the buyer on the above-described equipment which review included the Operator's Manual content, equipment care, adjustments, safe operation and applicable warranty policy.

Date \_\_\_\_\_

Dealer's Rep. Signature \_\_\_\_\_

The above equipment and Operator's Manual have been received by me and I have been thoroughly instructed as to care, adjustments, safe operation and applicable warranty policy.

Date \_\_\_\_\_

Owner's Signature \_\_\_\_\_

- White - FAST
- Yellow - Dealer
- Pink - Customer



## Fast RH15 / RH18 Rotary Hoe

ROTARY HOE SERIAL NUMBER \_\_\_\_\_

DATE PURCHASED \_\_\_\_\_ / \_\_\_\_\_ / \_\_\_\_\_

WIDTH \_\_\_\_\_

## General Information

All rights, especially copying and distribution rights are reserved. No part of this publication may be reproduced in any form or by any means, electronic or mechanical, including photocopying, without express written permission from Fast Ag Solutions.

Parts information in this manual represents components installed when product was manufactured based upon the best available information. Modifications made subsequent to initial delivery are not included. Always verify the parts and color required when ordering parts.

If you have any questions, please contact your Fast Ag Solutions Parts and Service Department.

## Parts Ordering Guide

1. Provide the Serial Number of your Chassis or System when ordering.
2. Use the Part Number and Description when ordering parts.
3. Provide the Page Title and Page Number if required.

## Parts Searching Guide

To search this PDF by keyword, name, description or part number, use **ctrl + f** for simple searches or **ctrl + shift + f** for advanced searches.

## Explanation of Parts Lists

The parts lists are broken down sub-assemblies and listed in 4 columns:

- **ITEM** - These numbers are found on the illustration associated with the parts list.
- **NS** - This item is NOT SHOWN, included for reference.
- **QTY.** - This is the quantity of parts needed in an assembly.
- **AR** - The quantity of this item is AS REQUIRED for the location.
- **PART NO.** - These are the part numbers associated to the ITEM.
- **DESCRIPTION** - This is the description of the part.



## Table of Contents

<b>Section</b>	<b>Page</b>
Table of Contents.....	7
Frame, Axle, Fold Arm, Tire, and Warning Light Assemblies.....	9
Parts List: Frame, Axle, Fold Arm, Tire, and Warning Light Assemblies.....	10
Frame, Axle, Fold Arm, Tire, and Warning Light Assemblies (cont.).....	11
Parts List: Frame, Axle, Fold Arm, Tire, and Warning Light Assemblies (cont.).....	12
Depth Adjust Assembly.....	13
Parts List 28090: Depth Adjust Assembly.....	14
Depth Adjust Sub-Assembly.....	15
Parts List 28089: Depth Adjust Sub-Assembly.....	16
Depth Adjust Slide Pivot Sub-Assembly.....	17
Parts List 28102: Depth Adjust Slide Pivot Sub-Assembly.....	17
8-Bolt Main Hub and Spindle Assembly (N45-8) 730008.....	18
Parts List: 8-Bolt Main Hub and Spindle Assembly (N45-8).....	18
6-Bolt Fold Arm Hub and Spindle Assembly (N709) 730106.....	19
Parts List: Hub and Spindle Assembly (N709).....	19
Bare Toolbar Assembly.....	20
Parts List 28075: Bare Toolbar Assembly.....	21
Strut Arm Assembly.....	22
Parts List: Strut Arm Assembly.....	23
LH Gauge Wheel Sub-Assembly.....	24
Parts List 28196: LH Gauge Wheel Sub-Assembly.....	25
RH Wing Gauge Sub-Assembly.....	26
Parts List 28195: RH Gauge Wheel Sub-Assembly.....	27
6-Bolt Gauge Wheel Hub and Spindle Assembly (N890) 730113.....	28
Parts List: 6-Bolt Gauge Wheel Hub and Spindle Assembly (N890).....	28
Toolbar Hardware and Rotary Hoe Wheel Gang Assemblies.....	29
Parts List 28046: Toolbar Hardware and Rotary Hoe Wheel Gang Assemblies.....	30
Rotary Hoe Wheel & Arm Sub-Assembly.....	31
Parts List: Rotary Hoe Wheel & Arm Sub-Assembly.....	32
15 Meter Toolbar Option.....	33
Parts List 28047: 15 Meter Toolbar Option.....	33
18 Meter Toolbar Option.....	34
Parts List 28048: 18 Meter Toolbar Option.....	35
Hydraulic Assembly.....	36



# ILLUSTRATED PARTS LIST

---

Parts List 28073: Hydraulic Assembly .....	37
<b>Hydraulic Fitting Locations .....</b>	<b>38</b>
Parts List 600113: Hydraulic Fitting Locations .....	39
<b>Center Cylinder Hoses .....</b>	<b>40</b>
Parts List 600113: Center Cylinder Hoses .....	41
<b>Field Latch Hoses .....</b>	<b>42</b>
Parts List: Field Latch Hoses .....	42
<b>Gauge Wheel Cylinder Hoses .....</b>	<b>43</b>
Parts List: Gauge Wheel Cylinder Hoses .....	44
<b>Hydraulic Diagram .....</b>	<b>45</b>
<b>Decals, 15 &amp; 18 Meter Toolbar, Fast .....</b>	<b>46</b>
Parts List: Decals, 15 & 18 Meter Toolbar, Fast .....	47



## Frame, Axle, Fold Arm, Tire, and Warning Light Assemblies

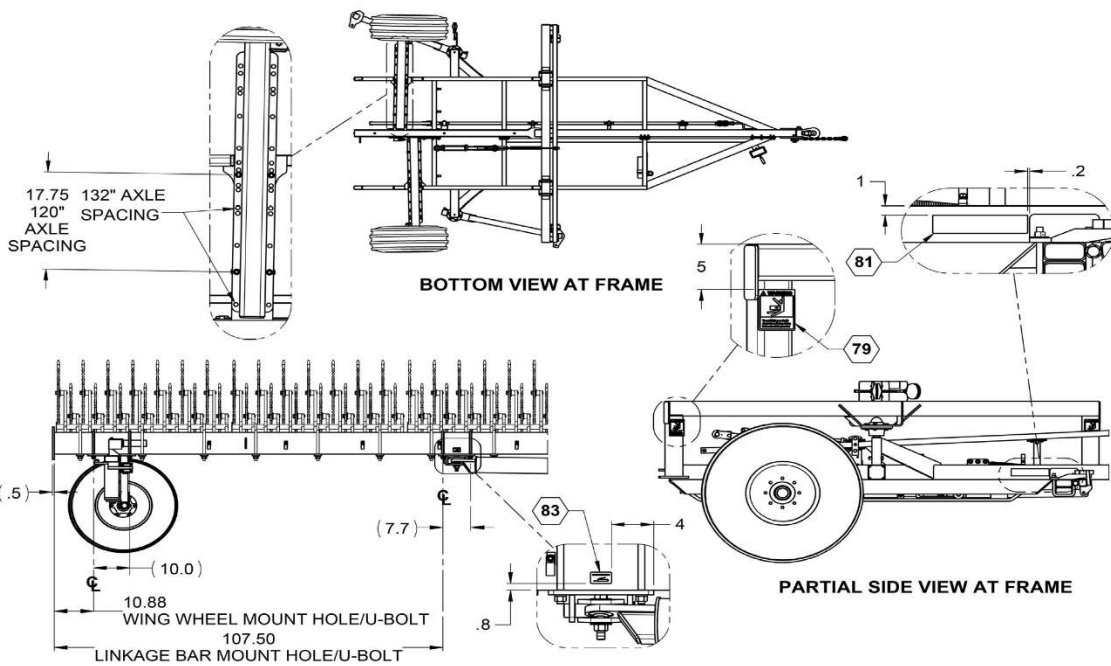
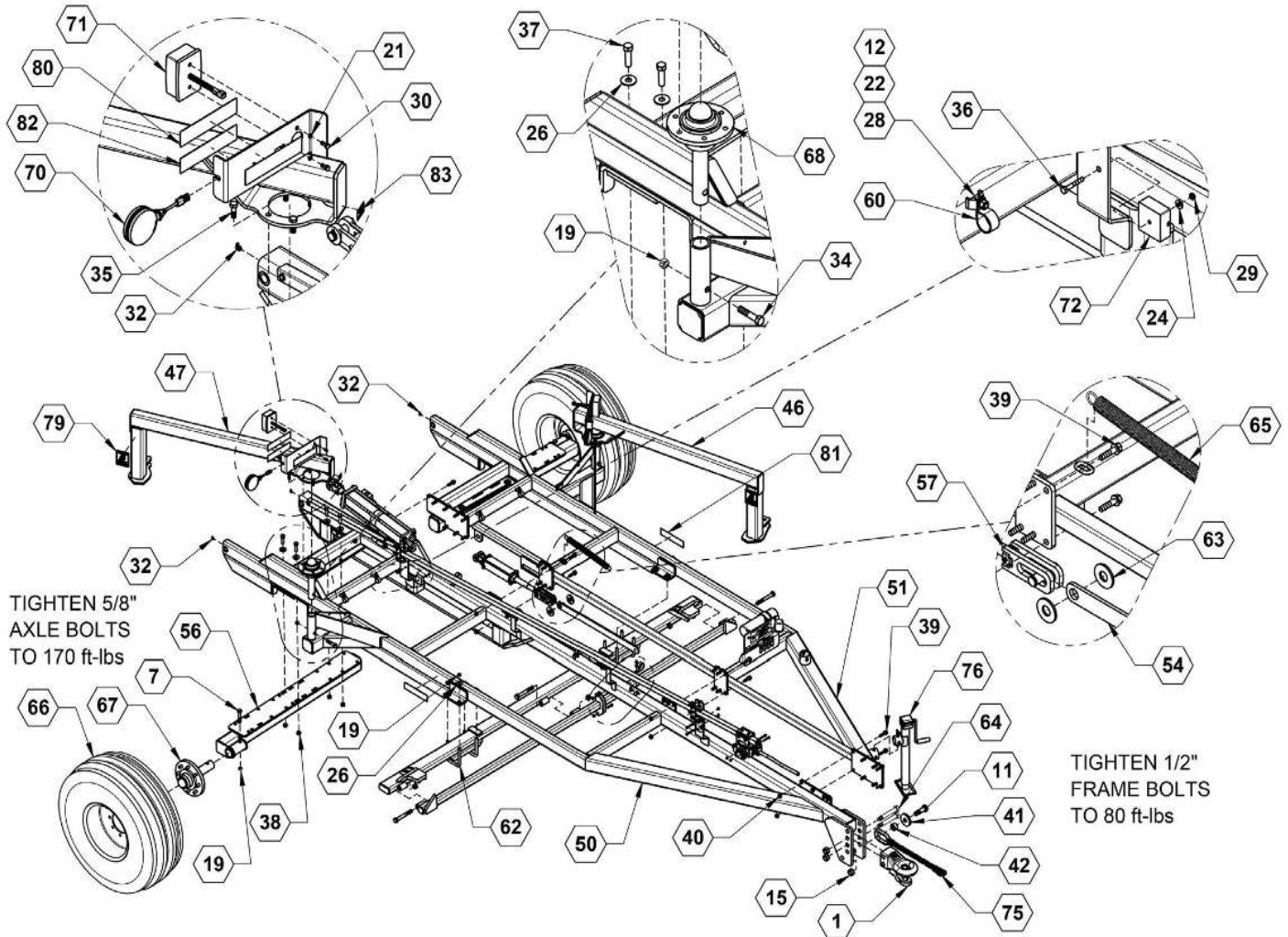



# ILLUSTRATED PARTS LIST

## Parts List: Frame, Axle, Fold Arm, Tire, and Warning Light Assemblies

ITEM	PART NO.	QTY.	DESCRIPTION
1	90SAHITCLG	1	HITCH, LARGE CAT 4
7	173	2	BOLT, HH 5/8 X 3-1/2 NC GR5 ZINC
11	201	1	BOLT, HH 1-8 X 3 1/2 GR5 ZINC
12	213	11	NUT, HEX 3/8-16 ZINC
15	234	3	NUT, HEX NYLOCK 1-8 ZINC
19	240	12	NUT, CENTERLOCK, 5/8-11, ZINC
21	248	4	WASHER, LOCK, 1/4 ZINC
22	250	11	LOCKWASHER, 3/8 ZINC
24	256	5	WASHER, FLAT, 1/4 ZINC
26	261	16	WASHER, FLAT, 5/8 ZINC
28	592	11	BOLT, CARRIAGE 3/8-16 X 1 ZINC
29	622	1	NUT, TOPLOCK 1/4-20 ZINC
30	737	4	BOLT, HH 8-1.25 X 20MM 8.8 ZINC
32	761	3	ZERK, 90°, 1/4-28 STRAIGHT PIPE THREAD
34	812	2	BOLT, HH 5/8-11 X 3 GR8 ZINC
35	813	8	BOLT, 1/2-20 UNF X 1-1/2 GR5 ZINC
36	814	3	BOLT, 1/4 X 1-3/4 GR5 ZINC
37	815	8	BOLT, HH 5/8-11 X 2-1/4 GR8 ZINC
38	817	8	NUT, CENTERLOCK, 5/8-11, GR8 ZINC
39	819	28	HHCS, FLANGED 1/2 X 2 G8 ZINC
40	820	28	NUT, FLANGED LOCK, 1/2-13 G8 ZINC
41	15829	1	WASHER PLATE, SAFETY CHAIN
42	15835	1	BUSHING, SAFETY CHAIN SPACER
46	27928	1	WLDMNT, LH FOLD ARM
47	27929	1	WLDMNT, RH FOLD ARM
50	28031	1	WLDMNT, RH FRAME
51	28032	1	WLDMNT, LH FRAME
54	28051	1	PLATE, 3/8" FIELD LATCH
56	28070	2	WLDMNT, FRONT AXLE
57	28073	1	ASSY, ROTARY HOE HYDRAULICS
62	590062	4	U-BOLT, 4 X 6 X 5/8 SQ. BEND, ZINC
63	590146	2	WASHER, FLAT 1" ZINC
64	590153	2	BOLT, HH 1-8 X6 -3/4 X 1-1/4 THD GR5 ZINC
65	590834	1	SPRING, CENTURY SPRING 4075
66	700208	2	WHEEL, TITAN 14L 16.1 SL, 8 BOLT RIM
67	730008	2	HUB & SPINDLE ASM, 8 BOLT
68	730106	2	HUB ASSEMBLY, N709
70	740024	2	LIGHT, AMBER WARNING
71	740025	2	TAIL LIGHT, RED
72	740031	1	LIGHT MODULE
75	790049	1	SAFETY CHAIN, 20,000LB
76	790051	1	JACK, 5000 LB SIDE WIND
79	800105	2	DECAL, WARNING-STAND CLEAR
80	800109	2	DECAL, RED REFLECTOR
81	800110	4	DECAL, AMBER REFLECTOR
82	800111	2	DECAL, ORANGE REFLECTOR
83	800287	7	DECAL, GREASE PIVOT POINTS

**Frame, Axle, Fold Arm, Tire, and Warning Light Assemblies (cont.)**

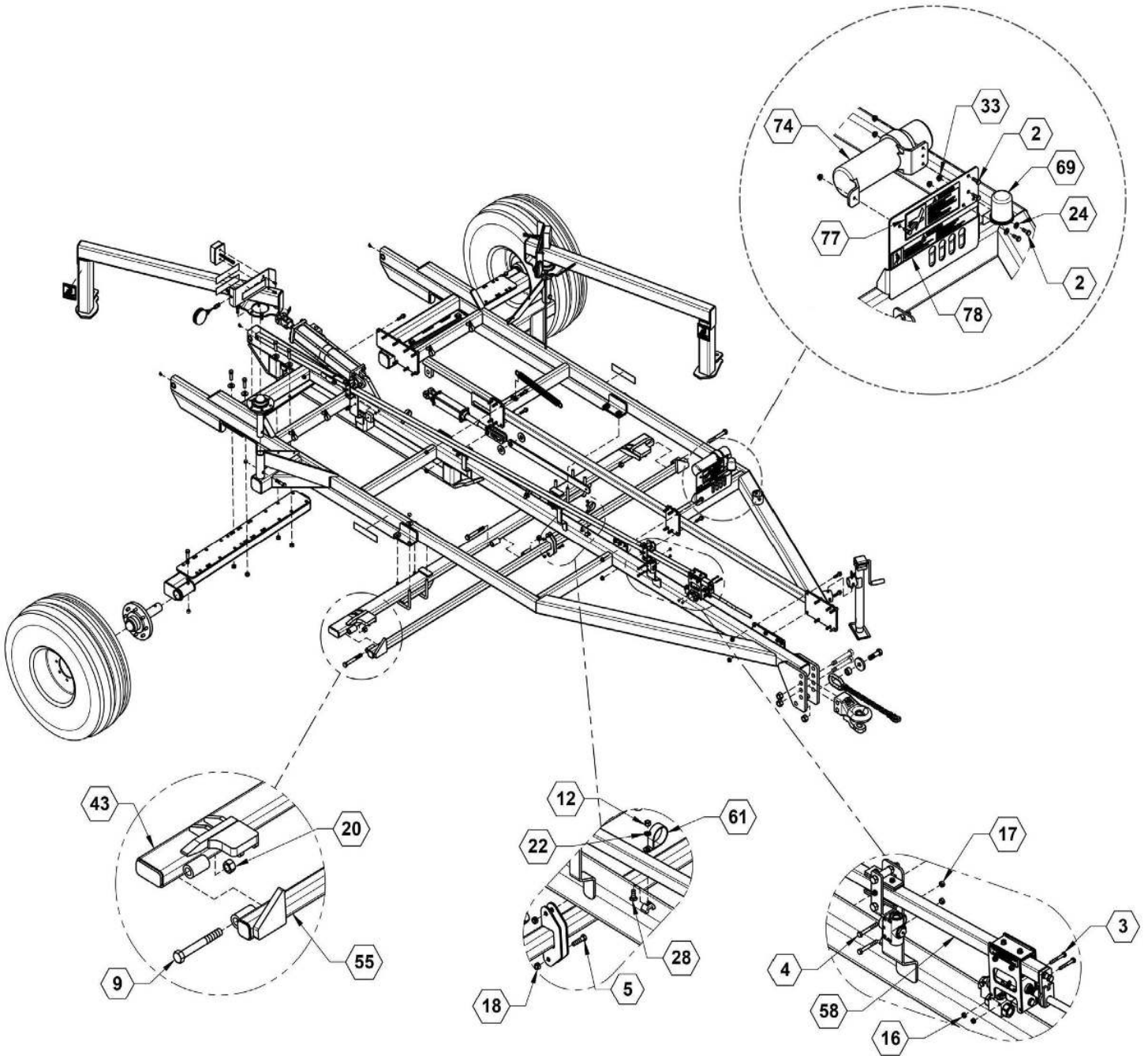



## ILLUSTRATED PARTS LIST

### Parts List: Frame, Axle, Fold Arm, Tire, and Warning Light Assemblies (cont.)

ITEM	PART NO.	QTY.	DESCRIPTION
2	101	7	BOLT, HH 1/4-20 X 3/4 GR5 ZINC
3	104	4	BOLT, HH 1/4-20 X 2 GR5 ZINC
4	118	2	BOLT, HH 5/16-18 X 2-1/2 GR5 ZINC
5	129	2	BOLT, HH 3/8-16 X 1-1/2 GR5 ZINC
9	192	3	BOLT HH 3/4-10 X 6 GR5 ZINC
12	213	11	NUT, HEX 3/8-16 ZINC
16	235	6	NUT, CENTERLOCK, 1/4-20 GR5 ZINC
17	236	2	NUT, CENTERLOCK, 5/16-18 GR5 ZINC
18	237	2	NUT, CENTERLOCK 3/8-16 ZINC
20	241	9	NUT, CENTERLOCK, 3/4-10 GR5 ZINC
22	250	11	LOCKWASHER, 3/8 ZINC
24	256	5	WASHER, FLAT, 1/4 ZINC
28	592	11	BOLT, CARRIAGE 3/8-16 X 1 ZINC
33	767	7	NUT, FLANGE, 1/4-20 ZINC
43	27490	1	WLDMNT, FIELD LOCK
55	28065	1	WLDMNT, FIELD LOCK PIVOT
58	28090	1	ASSY, DEPTH ADJUSTMENT
60	540035	6	P-CLAMP, 1-1/4"
61	540051	5	P-CLAMP, 2" W/3/8" HOLE
69	740018	1	LIGHT HARNESS HOLDER
74	750048	1	MANUAL HOLDER
77	800098	1	DECAL, WARNING-HYDRAULIC FLUID
78	800104	1	DECAL, WARNING-DO NOT SPEED



**Depth Adjust Assembly**

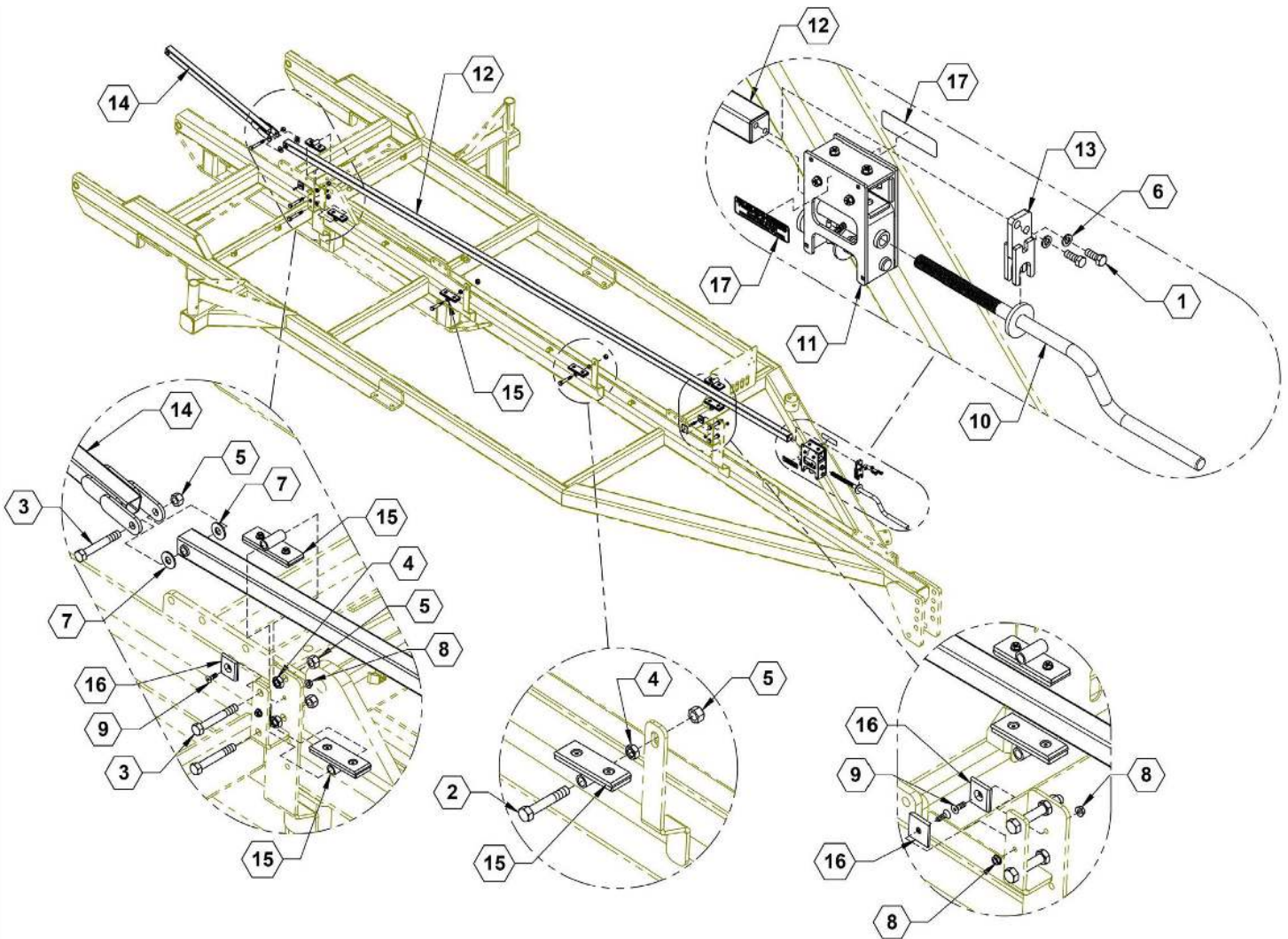

## Parts List 28090: Depth Adjust Assembly

ITEM	PART NO.	QTY.	DESCRIPTION
1	128	2	BOLT, HH 3/8-16 X 1 GR5 ZIN
2	156	2	BOLT, HH 1/2-13 X 3 GR5 ZIN
3	157	5	BOLT, HH 1/2-13 X 3-1/2 GR5 ZIN
4	223	6	NUT, HEX JAM 1/2-13 GR5 ZIN
5	231	7	NUT, HEX NYLOCK 1/2-13 ZIN
6	250	2	LOCKWASHER, 3/8 ZINC
7	260	2	WASHER, FLAT, 1/2 ZINC
8	767	4	NUT, FLANGE, 1/4-20 GR5 ZINC
9	800	4	FHSCS, 1/4-20 X 3/4 ZINC
10	28080	1	WLDMNT, ADJUST HANDLE
11	28089	1	ASSY, BUMP ADJUST
12	28091	1	WLDMNT, DEPTH TUBE
13	28096	1	WLDMNT, BASE ANCHOR
14	28100	1	WLDMNT, DEPTH FRONT TUBE
15	28102	6	ASSY, SLIDE PIVOT
16	28134	4	PAD, SIDE BRACE
17	800262	2	DECAL, DEPTH ADJUSTMENT

**Depth Adjust Sub-Assembly**

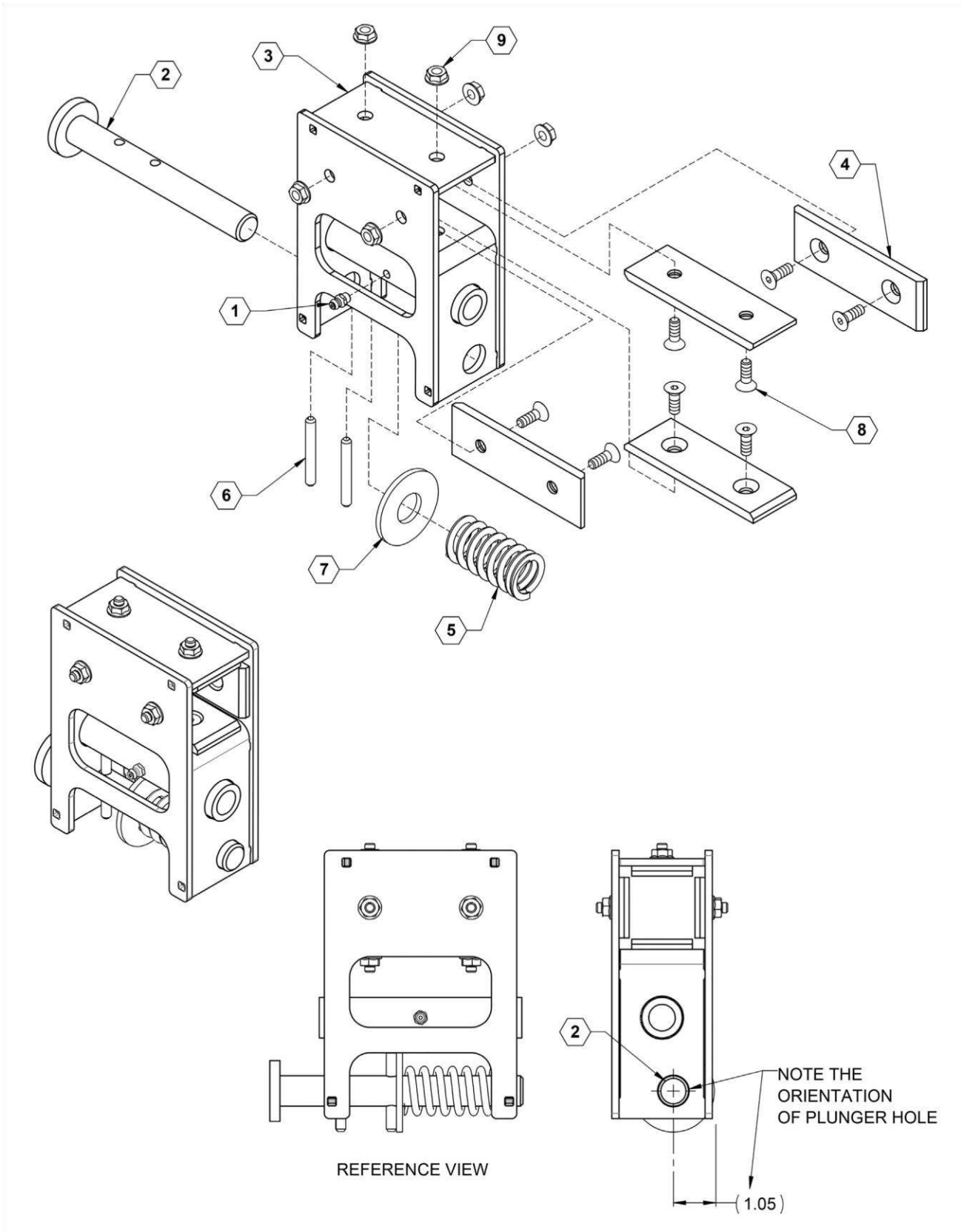

**Parts List 28089: Depth Adjust Sub-Assembly**

ITEM	PART NO.	QTY.	DESCRIPTION
1	759	1	ZERK, 1/4-28 STRAIGHT
2	28087	1	PLUNGER
3	28088	1	BUMP ADJUST
4	28095	4	POLY, DEPTH ADJUST SLIDE
5	590299	2	SPRING PIN 1/4 X 1-1/2, ZINC
6	28135	1	COMPRESSION SPRING
7	596259M	1	WASHER, FLAT 3/4 MAGNI
8	596629M	8	FHSCS 1/4-20 X 3/4 MAGNI
9	596767M	8	NUT, HEX FLANGE 1/4-20 MAGNI



## Depth Adjust Slide Pivot Sub-Assembly

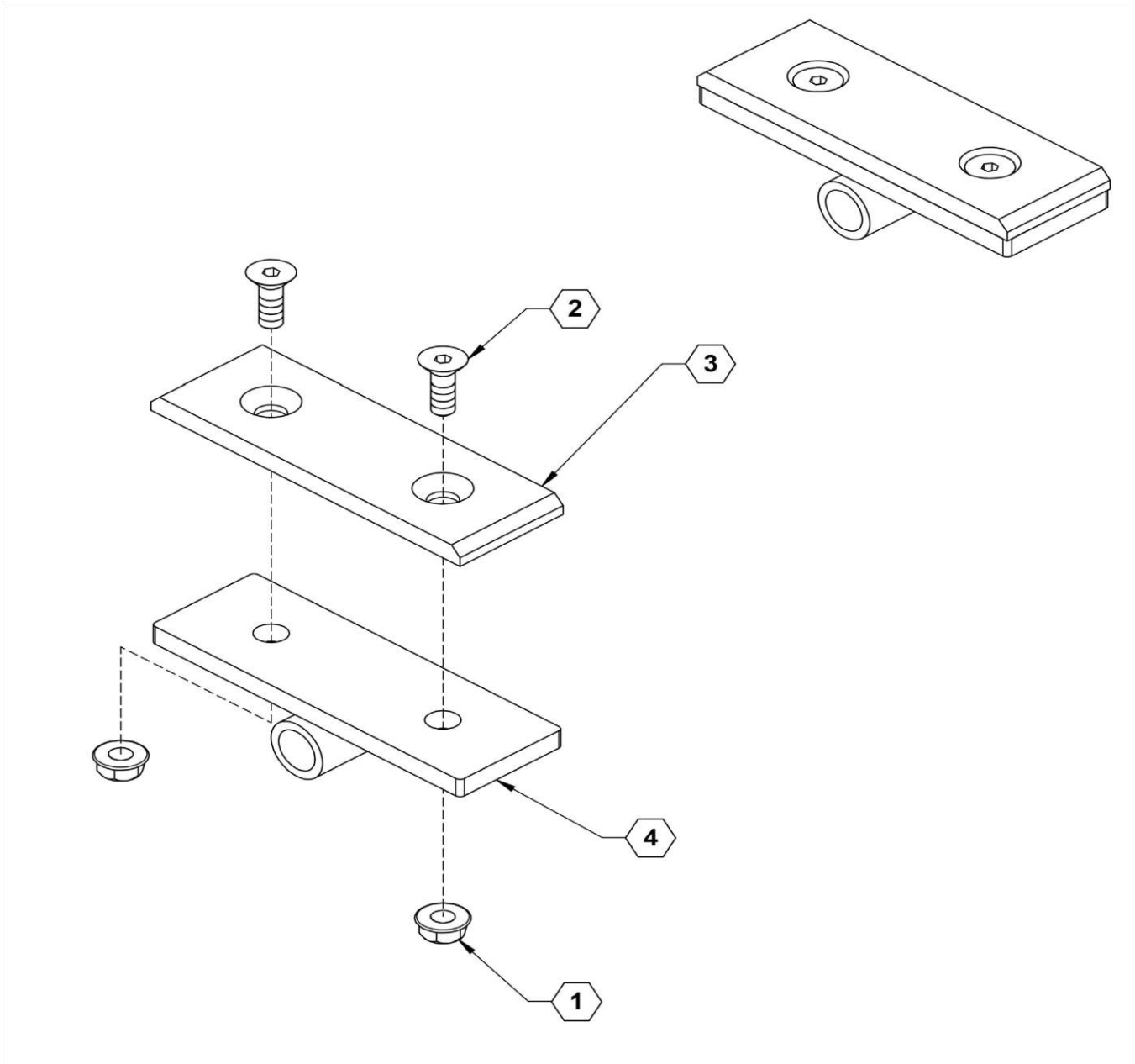

### Parts List 28102: Depth Adjust Slide Pivot Sub-Assembly

ITEM	PART NO.	QTY.	DESCRIPTION
1	767	2	NUT, FLANGE, 1/4-20 GR5 ZINC
2	800	2	FHSCS, 1/4-20 X 3/4 ZINC
3	28095	1	POLY, DEPTH ADJUST SLIDE
4	28103	1	WLDMNT, SLIDE PIVOT

## 8-Bolt Main Hub and Spindle Assembly (N45-8) 730008

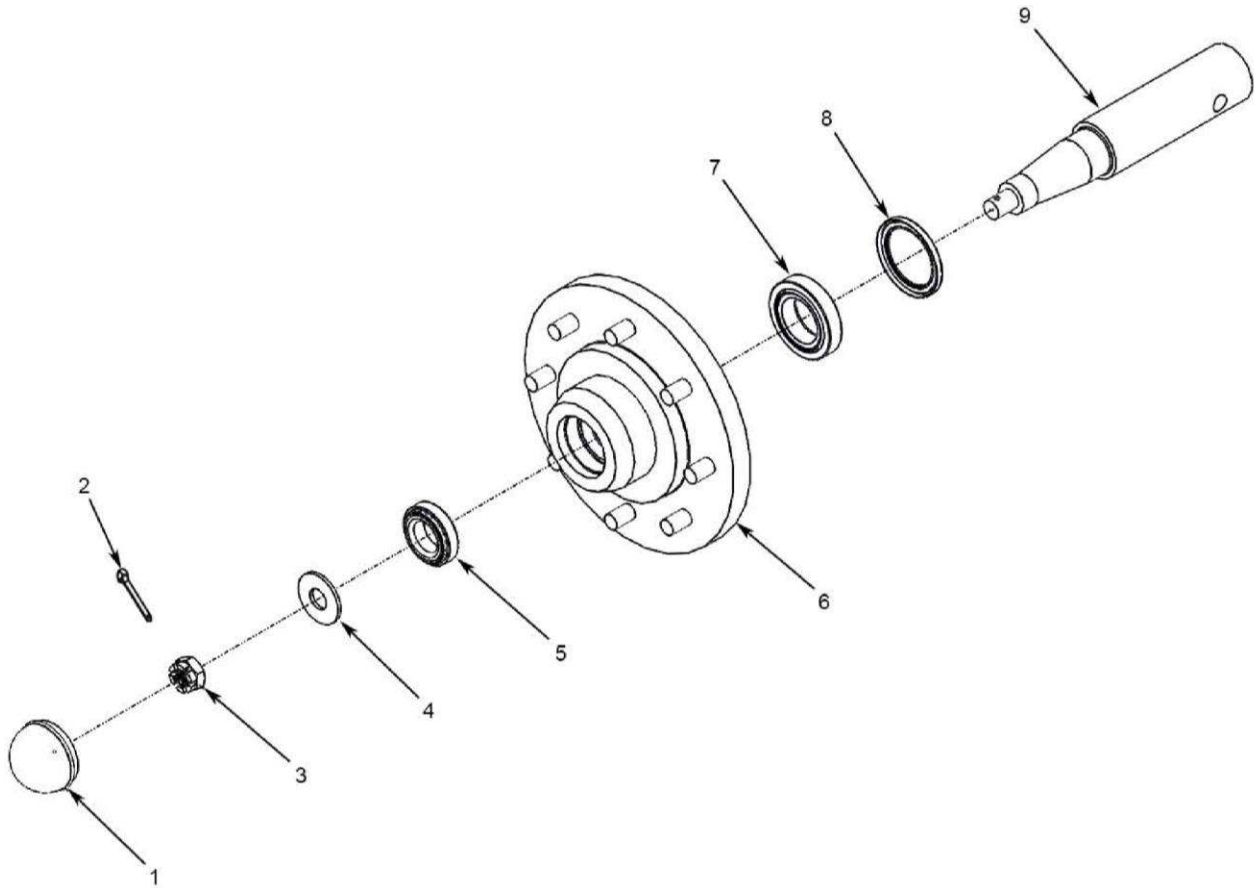

### Parts List: 8-Bolt Main Hub and Spindle Assembly (N45-8)

ITEM	VENDOR PART NO.	PART NO.	QTY.	DESCRIPTION
0		730008	1	COMPLETE HUB AND SPINDLE ASSEMBLY (N45-8)
1	909905		1	CAP
2	N/A	N/A	1	COTTER PIN
3	912953		1	NUT
4	913616		1	WASHER
5	LM67048		1	OUTER CUP AND CONE BEARING
6	730008		1	HUB
7	LM603049		1	INNER CUP AND CONE BEARING
8	906297		1	SEAL
9	07-08400		1	SPINDLE

## 6-Bolt Fold Arm Hub and Spindle Assembly (N709) 730106

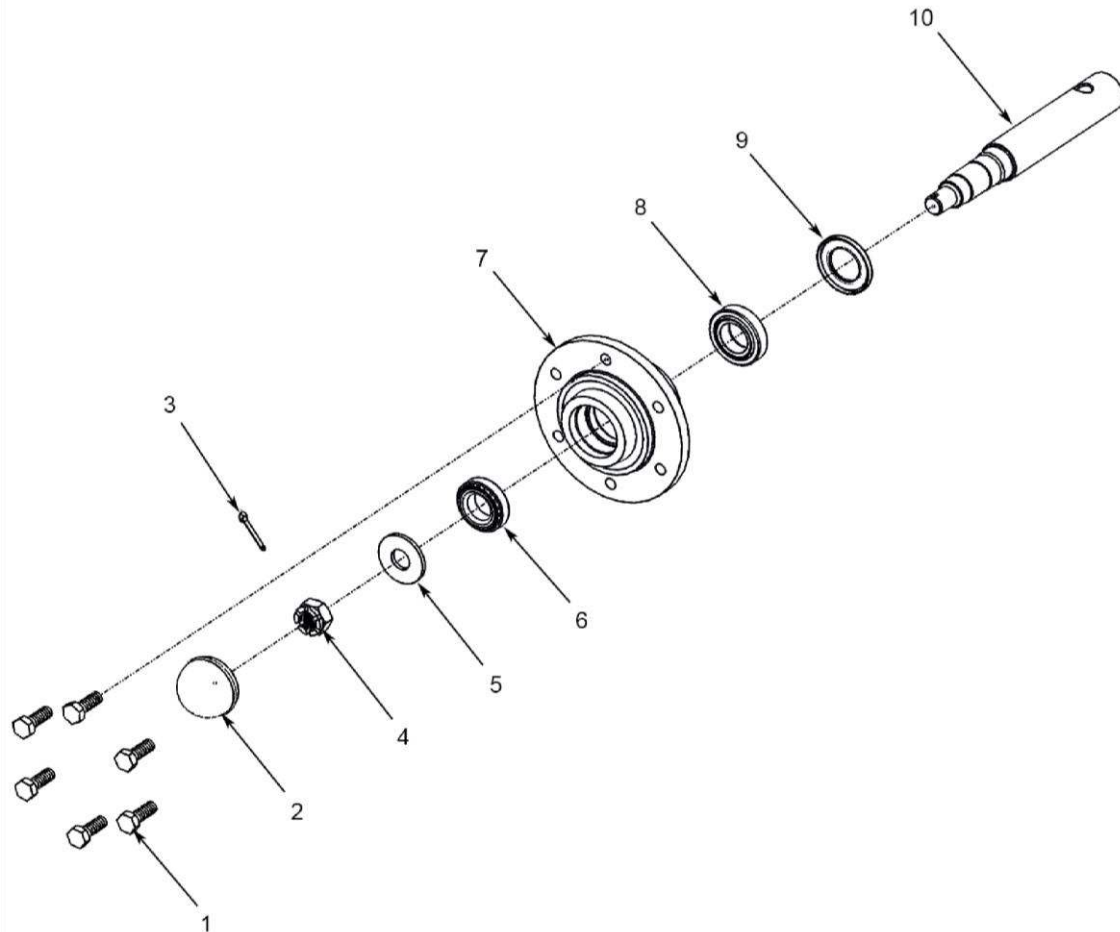

### Parts List: Hub and Spindle Assembly (N709)

ITEM	VENDOR PART NO.	PART NO.	QTY.	DESCRIPTION
0		730106	1	COMPLETE HUB AND SPINDLE ASSEMBLY (N709)
1	943549		6	BOLT
2	909905		1	CAP
3	N/A	N/A	1	COTTER PIN
4	912952		1	NUT
5	913683		1	WASHER
6	LM67048		1	OUTER CUP AND CONE BEARING
7*	730106		1	HUB N709 * INCLUDED WITH 730106
8	LM48510		1	INNER CUP AND CONE BEARING
9	906283		1	SEAL
10*	730106		1	SPINDLE * INCLUDED WITH 730106

## Bare Toolbar Assembly

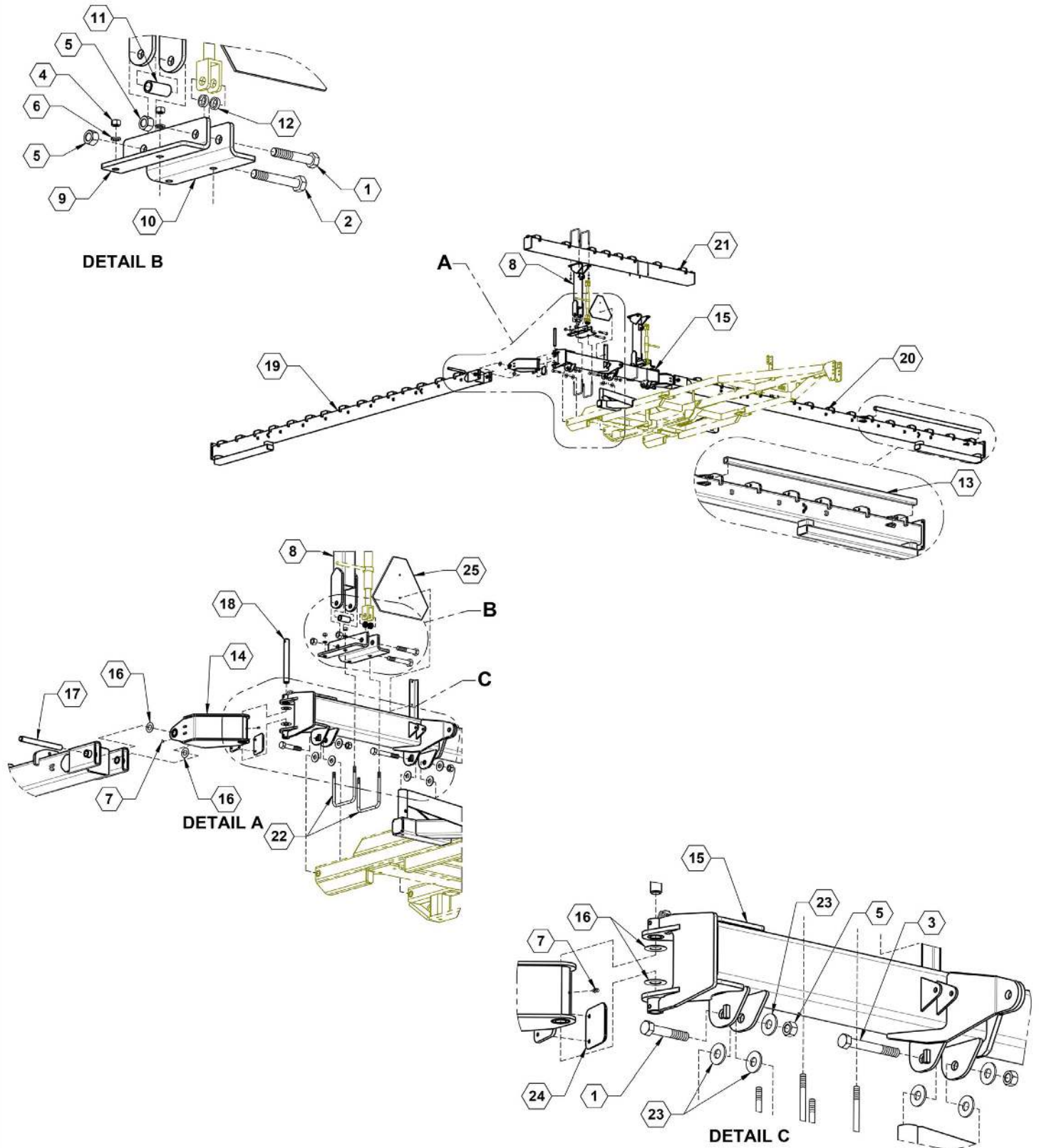

## Parts List 28075: Bare Toolbar Assembly

ITEM	PART NO.	QTY.	DESCRIPTION
1	205	4	BOLT, HEX 1-8X5-1/2 GR5 ZINC
2	207	2	BOLT, HH 1-8 X 6-1/2 G5 ZINC
3	209	1	BOLT, HH 1-8X7-1/2 GR5 ZINC
4	216	16	NUT, HEX 5/8-11, ZINC
5	242	7	NUT, CENTERLOCK, 1-8 ZINC
6	253	16	LOCKWASHER, 5/8" ZINC
7	761	4	ZERK, 90° , 1/4-28 STRAIGHT PIPE THREAD
8	27470	2	CENTER LIFTARM, WELDMENT
9	27477	2	PLATE, CENTER LIFTARM MOUNT LH
10	27478	2	PLATE, CENTER LIFTARM MOUNT RH
11	27537	2	BUSHING, LONG SPACER
12	27538	4	BUSHING, SHORT SPACER
13	27959	1	TUBE, CROSS BAR
14	27999	2	FLEX JOINT WLDMNT
15	28002	1	CENTER TOOLBAR WLDMT
16	28037	8	1.5ID x 2.5OD THRUST WASHER
17	28050	2	PIN, 1.25 DIAMETER
18	28058	2	PIVOT PIN
19	28293	1	RH MAIN WING WELDMENT
20	28294	1	LH MAIN WING WELDMENT
21	28295	1	CENTER GANG BAR, WELDMENT
22	530172	8	U-BOLT, 7 X 7 X 5/8, ZINC
23	590146	9	WASHER, FLAT 1" ZINC
24	590265	2	PLATE, WEAR
25	790017	1	SIGN, SMV PLASTIC MOLDED

**Strut Arm Assembly**

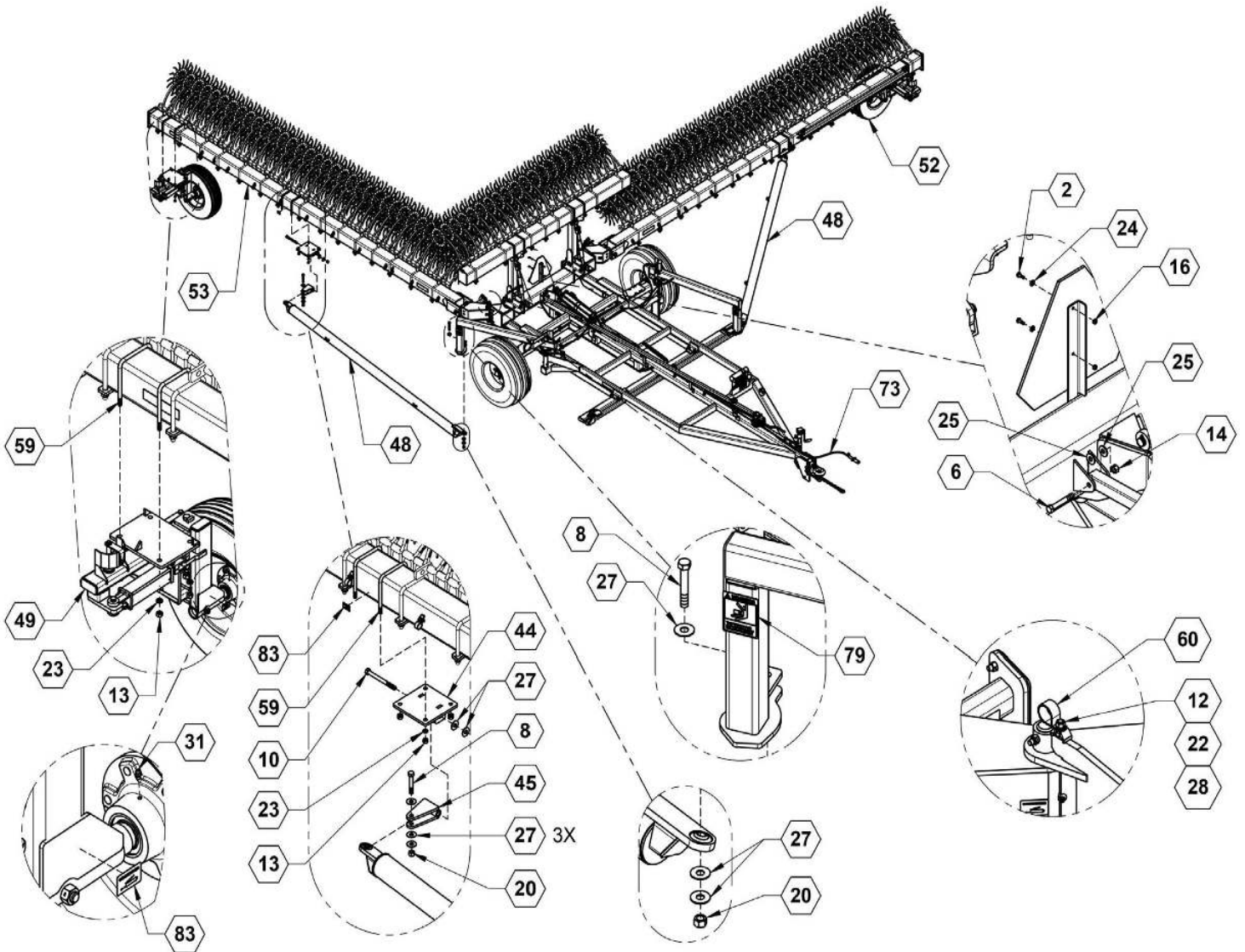



## Parts List: Strut Arm Assembly

ITEM	PART NO.	QTY.	DESCRIPTION
2	101	7	BOLT, HH 1/4-20 X 3/4 GR5 ZINC
6	157	1	BOLT, HH 1/2-13 X 3-1/2 GR5 ZINC
8	189	4	BOLT, HH 3/4-10 X 4 1/2 GR5 ZINC
10	196	2	BOLT, 3/4-10 X 8 GR5 ZINC
12	213	11	NUT, HEX 3/8-16 ZINC
13	216	16	NUT, HEX 5/8-11, ZINC
14	231	1	NUT, HEX NYLOCK 1/2-13 ZINC
16	235	6	NUT, CENTERLOCK, 1/4-20 GR5 ZINC
20	241	9	NUT, CENTERLOCK, 3/4-10 GR5 ZINC
22	250	11	LOCKWASHER, 3/8 ZINC
23	253	16	LOCKWASHER, 5/8" ZINC
24	256	5	WASHER, FLAT, 1/4 ZINC
25	260	2	WASHER, FLAT, 1/2 ZINC
27	262	16	WASHER, FLAT 3/4 ZINC
28	592	11	BOLT, CARRIAGE 3/8-16 X 1 ZINC
31	759	6	ZERK, 1/4-28 STRAIGHT PIPE THREAD
44	27506	2	WLDMNT, LINKAGE MOUNT
45	27510	2	WLDMNT, LINKAGE SWING
48	28007	2	WLDMNT, STRUT TUBE
49	28020	1	ASSY, RH GAUGE WHEEL
52	28035	1	ASSY, LH GAUGE WHEEL
53	28046	1	ASSY, BASE TOOLBAR
59	530172	8	U-BOLT, 7 X 7 X 5/8, ZINC
60	540035	6	P-CLAMP, 1-1/4"
73	740047	1	HARNES, TAILIGHT
79	800105	2	DECAL, WARNING-STAND CLEAR
83	800287	7	DECAL, GREASE PIVOT POINTS

**LH Gauge Wheel Sub-Assembly**

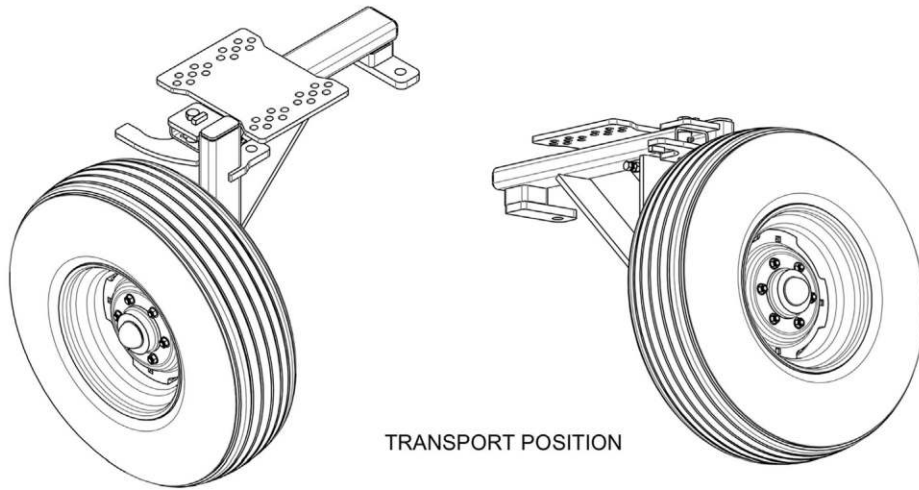

TRANSPORT POSITION

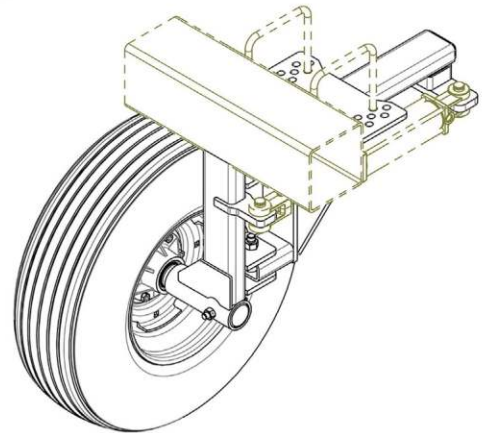

FIELD POSITION

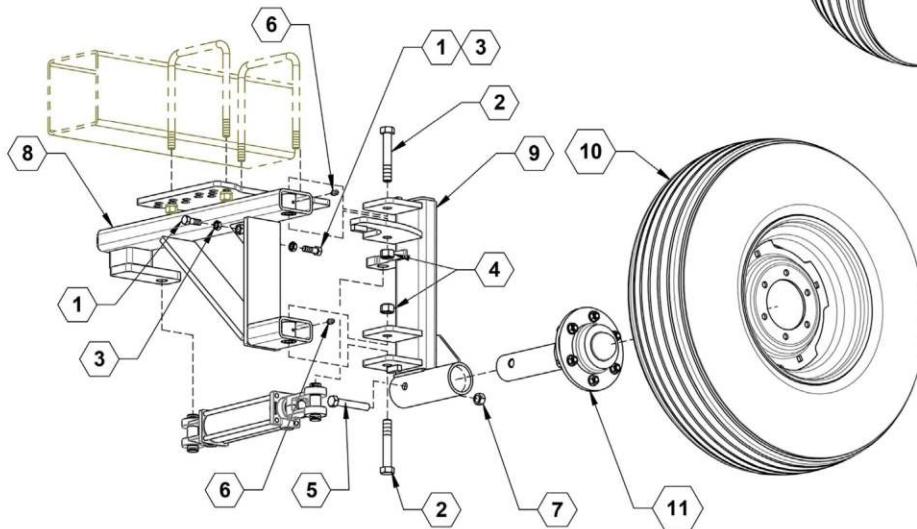



## Parts List 28196: LH Gauge Wheel Sub-Assembly

ITEM	PART NO.	QTY.	DESCRIPTION
1	596332M	2	BOLT, HH 5/8-11 X 2-1/4 GR8 MAGNI
2	189	2	BOLT, HH 3/4-10 X 4 1/2 GR5 ZINC
3	224	2	NUT, HEX JAM 5/8-11 GR5 ZINC
4	233	2	NUT, HEX NYLOCK 3/4-10 ZINC
5	373	1	5/8-11 X 4 Gr8 Bolt
6	760	2	ZERK, GREASE 1/4-28 45~
7	817	1	NUT, CENTERLOCK, 5/8-11, GR8 ZINC
8	28034	1	WLDMT, LH REAR TIRE MOUNT
9	28192	1	WLDMT, LH REAR TIRE PIVOT
10	700210	1	WHEEL, TITAN 11L 15 SL, 6 BOLT
11	730113	1	HUB ASSY, N890

**RH Wing Gauge Sub-Assembly**

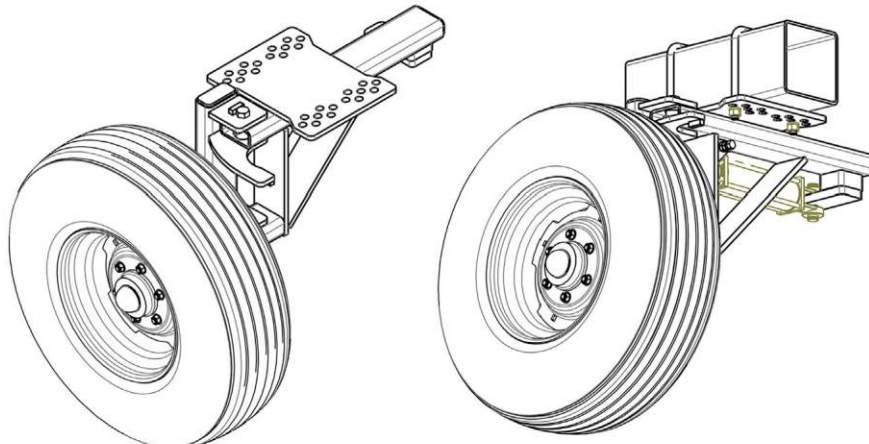

TRANSPORT POSITION

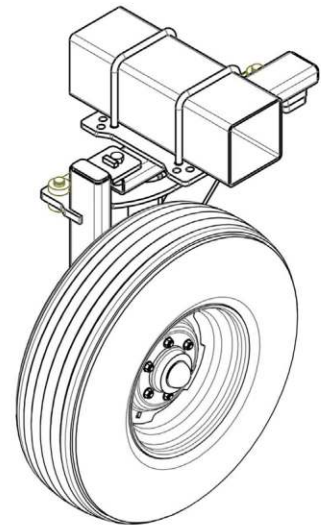

FIELD POSITION

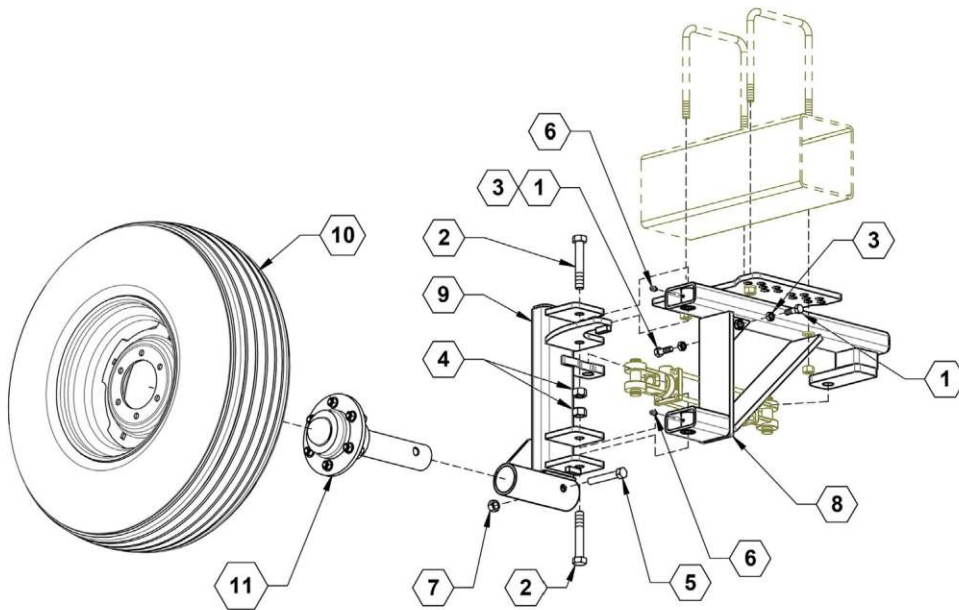

## Parts List 28195: RH Gauge Wheel Sub-Assembly

ITEM	PART NO.	QTY.	DESCRIPTION
1	596332M	2	BOLT, HH 5/8-11 X 2-1/4 GR8 MAGNI
2	189	2	BOLT, HH 3/4-10 X 4 1/2 GR5 ZINC
3	224	2	NUT, HEX JAM 5/8-11 GR5 ZINC
4	233	2	NUT, HEX NYLOCK 3/4-10 ZINC
5	373	1	5/8-11 X 4 Gr8 Bolt
6	760	2	ZERK, GREASE 1/4-28 45~
7	817	1	NUT, CENTERLOCK, 5/8-11, GR8 ZINC
8	28018	1	WLDMT, RH REAR TIRE MOUNT
9	28193	1	WLDMT, RH REAR TIRE PIVOT
10	700210	1	WHEEL, TITAN 11L 15 SL, 6 BOLT
11	730113	1	HUB ASSY, N890

## 6-Bolt Gauge Wheel Hub and Spindle Assembly (N890) 730113

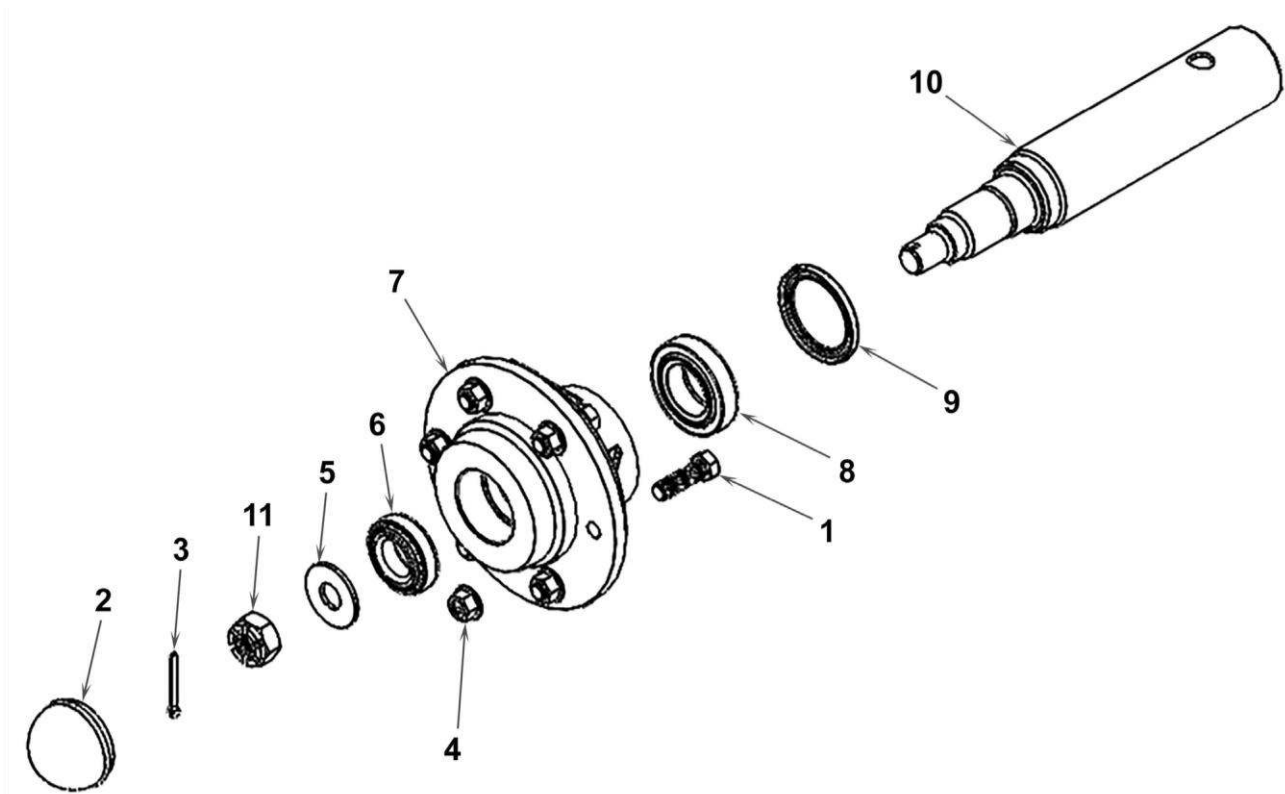

### Parts List: 6-Bolt Gauge Wheel Hub and Spindle Assembly (N890)

ITEM	VENDOR PART NO.	PART NO.	QTY.	DESCRIPTION
0		730113	1	COMPLETE HUB AND SPINDLE ASSEMBLY (N890)
1	913574		6	STUD
2	909905		1	CAP
3	905936		1	COTTER PIN
4	912927		6	NUT
5	913616		1	WASHER
6	LM67048		1	OUTER CUP AND CONE BEARING
7*	730113		1	HUB N890 * INCLUDED WITH 730113
8	LM501349		1	INNER CUP AND CONE BEARING
9	906985		1	SEAL
10*	730114		1	SPINDLE * INCLUDED WITH 730113
11	912952		1	NUT

## Toolbar Hardware and Rotary Hoe Wheel Gang Assemblies

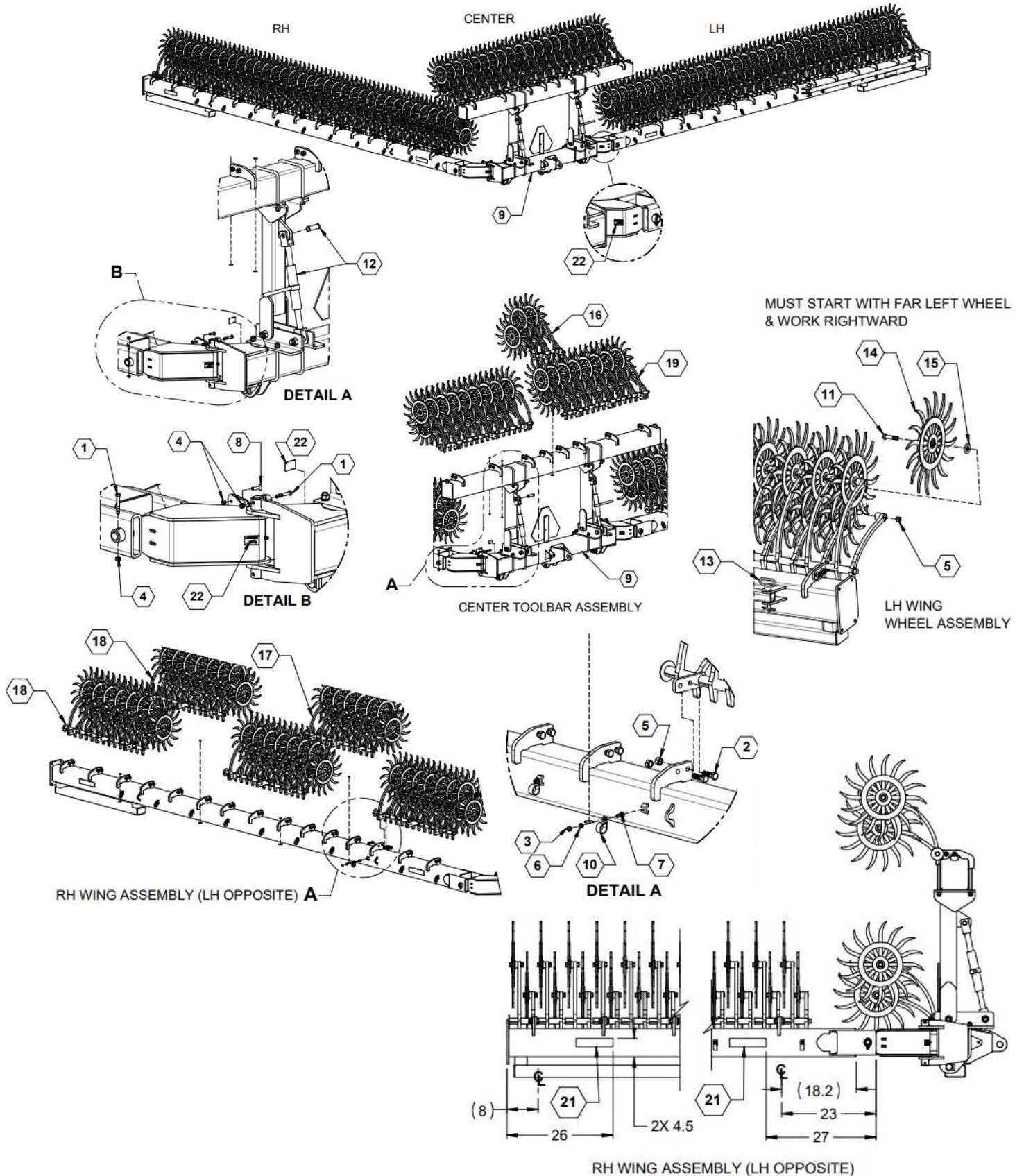

## Parts List 28046: Toolbar Hardware and Rotary Hoe Wheel Gang Assemblies

ITEM	PART NO.	QTY.	DESCRIPTION
1	131	4	BOLT, HH 3/8-16 X 2-1/2 GR5 ZINC
2	170	76	5/8-11 x 2 HH BOLT
3	213	20	NUT, HEX 3/8-16 ZINC
4	237	8	NUT, CENTERLOCK 3/8-16 ZINC
5	240	250	NUT, CENTER LOCK, 5/8-11 GR5 ZP
6	250	20	LOCKWASHER, 3/8 ZINC
7	592	20	BOLT, CARRIAGE 3/8-16 X 1 ZINC
8	726	4	BOLT, FHSCS 3/8-16 X 1-1/4 ZINC
9	28075	1	ASSEMBLY, BARE BASE TOOLBAR
10	540035	20	P-CLAMP, 1-1/4"
11	590347	174	BOLT, HH 5/8-11X2.75 GR5 ZP
12	590833	2	TURNBUCKLE, 24" RATCHETING
13	790043	2	HITCH PIN, 5/8" X 4"
14	790071	174	WHEEL, YETTER ROTARY HOE
15	790072	174	BEARING SHIELD, 3400-408
16	790077	1	YETTER 5 WHEEL AXLE ASSEMBLY
17	790078	2	YETTER 12 WHEEL TAB MOUNT AXLE ASSEMBLY
18	790079	8	YETTER 14 WHEEL TAB MOUNT AXLE ASSEMBLY
19	790080	1	YETTER 16 WHEEL TAB MOUNT AXLE ASSEMBLY
20	790081	1	YETTER 17 WHEEL TAB MOUNT AXLE ASSEMBLY
21	800110	4	DECAL, AMBER, REFLECTOR
22	800287	7	DECAL, GREASE PIVOT POINTS



**Rotary Hoe Wheel & Arm Sub-Assembly**

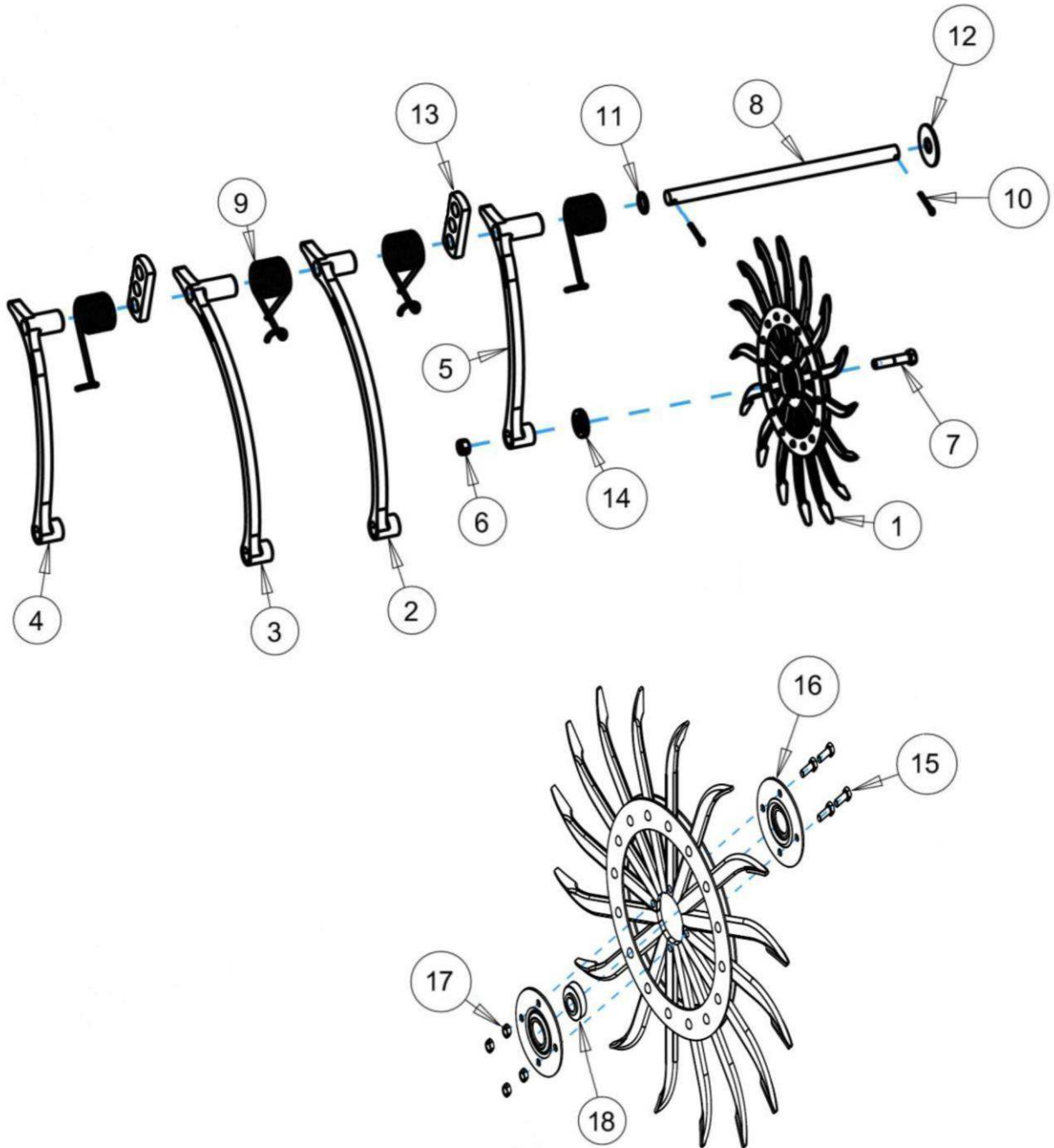

## Parts List: Rotary Hoe Wheel & Arm Sub-Assembly

ITEM	PART NO.	QTY.	DESCRIPTION
1*	790071	1	PAINTED WHEEL ASSEMBLY, BLACK
2	2555-119	A/R	SHORT HUB - REAR ARM CASTING
3	2555-117	A/R	LONG HUB - FRONT ARM CASTING
4	2555-118	A/R	SHORT HUB - FRONT ARM CASTING
5	2555-116	A/R	LONG HUB - REAR ARM CASTING
6*	240	A/R	5/8"-11 LOCK HEX NUT, ZP
7*	590347	A/R	5/8"-11 X 2-3/4" HEX HEAD BOLT, GR5 ZP
8	790077	1	5 WHEEL AXLE ASSEMBLY, TAB MOUNT
8	790078	1	12 WHEEL AXLE ASSEMBLY, TAB MOUNT
8	790079	1	14 WHEEL AXLE ASSEMBLY, TAB MOUNT
8	790080	1	16 WHEEL AXLE ASSEMBLY, TAB MOUNT
8	790091	1	17 WHEEL AXLE ASSEMBLY, TAB MOUNT
9	2550-716	A/R	ROTARY HOE TORSION SPRING
10	2531-125	A/R	1/4"X X1-3/4" COTTER KEY. ZP
11	2527-564	A/R	1" ID X 1-1/2" OD X 14GA M.B.
12	3400-383	A/R	3" OD X 1-1/32" ID X 1/8" WASHER
13	28290	A/R	TAB
14*	790072	A/R	BEARING SHIELD
15	2502-203	4	BOLT, 5/16-18 HHCS GR5 ZP
16	3400-341	2	HUB
17	2520-205	4	NUT, 5/16-18 LOCK HEX GR A ZP
18	2550-016	1	BEARING
			* NOT INCLUDED WITH SECTION ASSEMBLIES ABOVE



## 15 Meter Toolbar Option

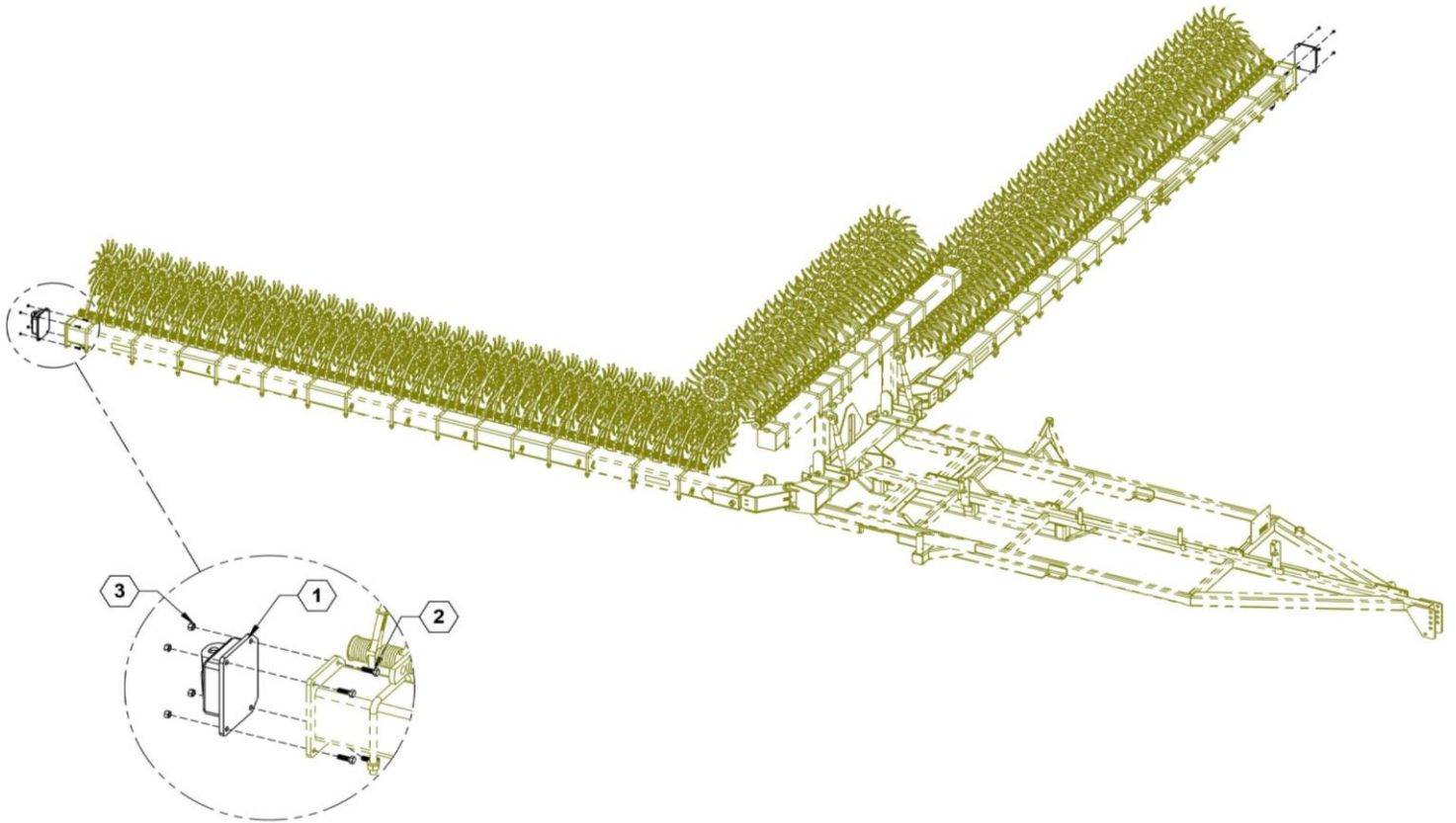

### Parts List 28047: 15 Meter Toolbar Option

ITEM	PART NO.	QTY.	DESCRIPTION
1	28022	2	CROSS TUBE MOUNT
2	596153M	8	BOLT, HH 1/2-13X1-1/2 GR5 MAGNI
3	596239M	8	NUT, CENTERLOCK, 1/2-13 MAGNI

**18 Meter Toolbar Option**

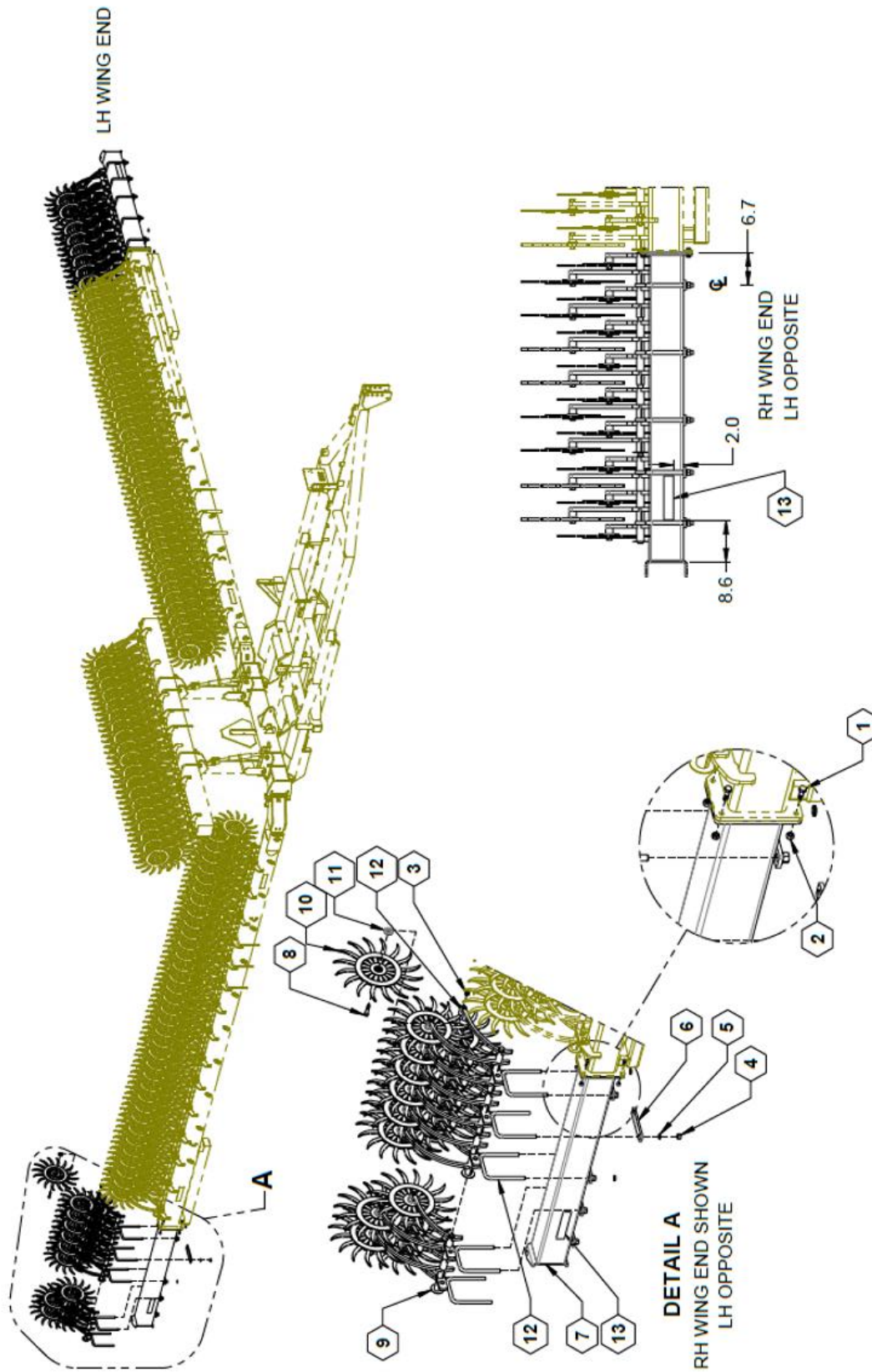

## Parts List 28048: 18 Meter Toolbar Option

ITEM	PART NO.	QTY.	DESCRIPTION
1	153	8	BOLT, HH 1/2-13 X 1.50, ZINC
2	239	8	NUT, CENTER LOCK, 1/2-13 GR5 ZP
3	240	34	NUT, CENTER LOCK, 5/8-11 GR5 ZP
4	241	20	NUT, CENTERLOCK, 3/4-10 GR5 ZINC
5	254	20	LOCKWASHER, 3/4 ZINC
6	27542	10	PLATE, ROW UNIT BOLT MOUNT
7	28028	2	WLDMT, LH 18M/60FT WING EXTENSION
8	590347	34	BOLT, HH 5/8-11X2.75 GR5 ZP
9	790066	2	YETTER 5 WHEEL AXLE ASSY
10	790071	34	WHEEL, YETTER ROTARY HOE
11	790072	34	BEARING SHIELD, 3400-408
12	790074	2	YETTER 12 WHEEL AXLE ASSY
13	800110	2	DECAL, AMBER, REFLECTOR

**Hydraulic Assembly**

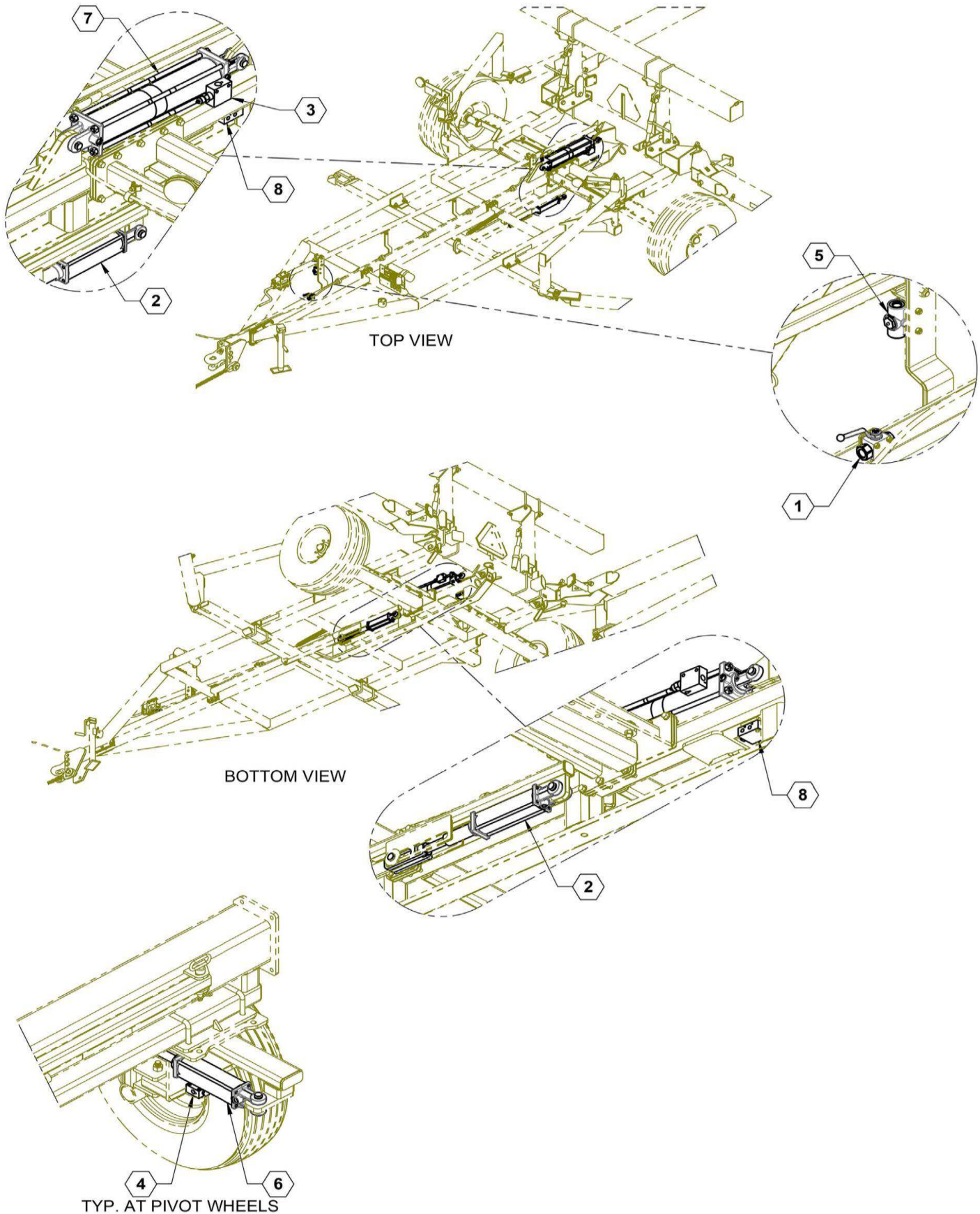

**Parts List 28073: Hydraulic Assembly**

ITEM	PART NO.	QTY.	DESCRIPTION
1	34372	1	BLOCKING VALVE/WITH MOUNTING HOLES
2	28072	1	ASSY, FIELD LATCH CYLINDER
2	28054	1	SLOTTED CYLINDER CLEVIS
3	500049	1	VALVE, COUNTERBALANCE
4	500059	2	CHECK VALVE, P.O., SINGLE
5	610154	1	VALVE, PUSH BUTTON BLOCKING
6	620023	2	CYLINDER, 25TD08-112
7	620099	1	CYLINDER 4 X 20" 1.75" ROD 3000PSI
8	630035	1	FLOW DIVIDER



**Hydraulic Fitting Locations**

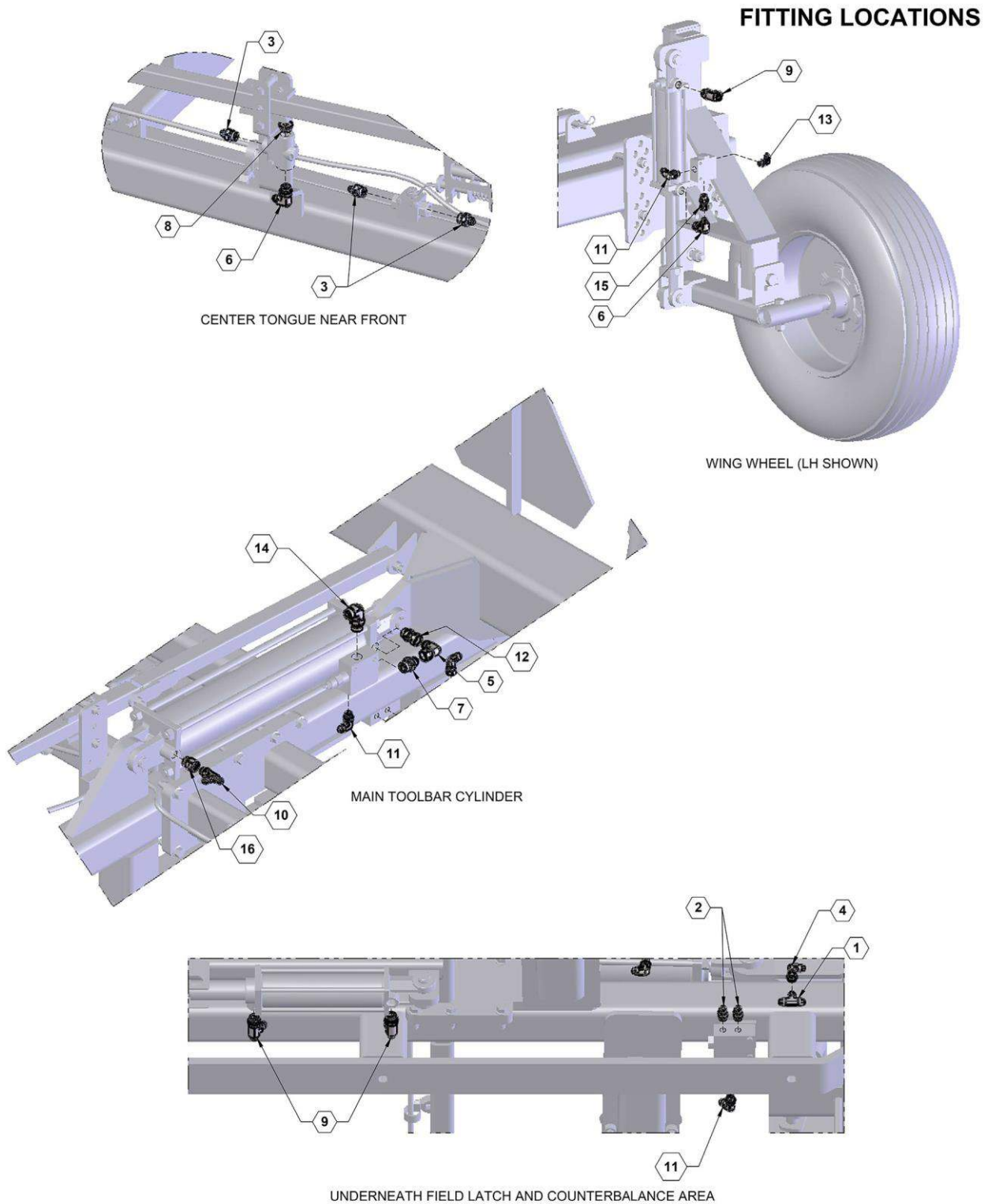

## Parts List 600113: Hydraulic Fitting Locations

ITEM	PART NO.	QTY.	DESCRIPTION
1	610005	1	JIC UNION TEE #6
2	610010	2	JIC #6 TO ORING #6
3	610011	3	JIC #6 TO ORING #8
4	610023	1	JIC #6 90 DEG
5	610024	1	JIC #8 90 DEG
6	610030	3	JIC #6 TO ORING #8 90 DEG
7	610060	1	JIC #8 TO ORING #10
8	610062	1	#8 O-RING PLUG
9	610066	4	#8 ORING TO JIC #6 RUN TEE
10	610074	1	JIC TO ORING #6 RUN TEE
11	610078	4	JIC #6 TO #6 ORING 90~
12	610083	1	FITTING #8 ORB X #8 JICF
13	610084	2	ELBOW 90~ #4 JIC #4 O-RING
14	610086	1	JIC #8 TO O-RING #10 ELBOW 90°
15	610113	2	#6 O-RING TO #6 JICF SWIVEL
16	610159	1	#8 MORB x #6 FORB REDUCER

## Center Cylinder Hoses

CENTER CYLINDER PRESSURE: BLACK HOSE  
CENTER CYLINDER RETURN: GRAY HOSE

CENTER CYLINDER HYDRAULIC LINES

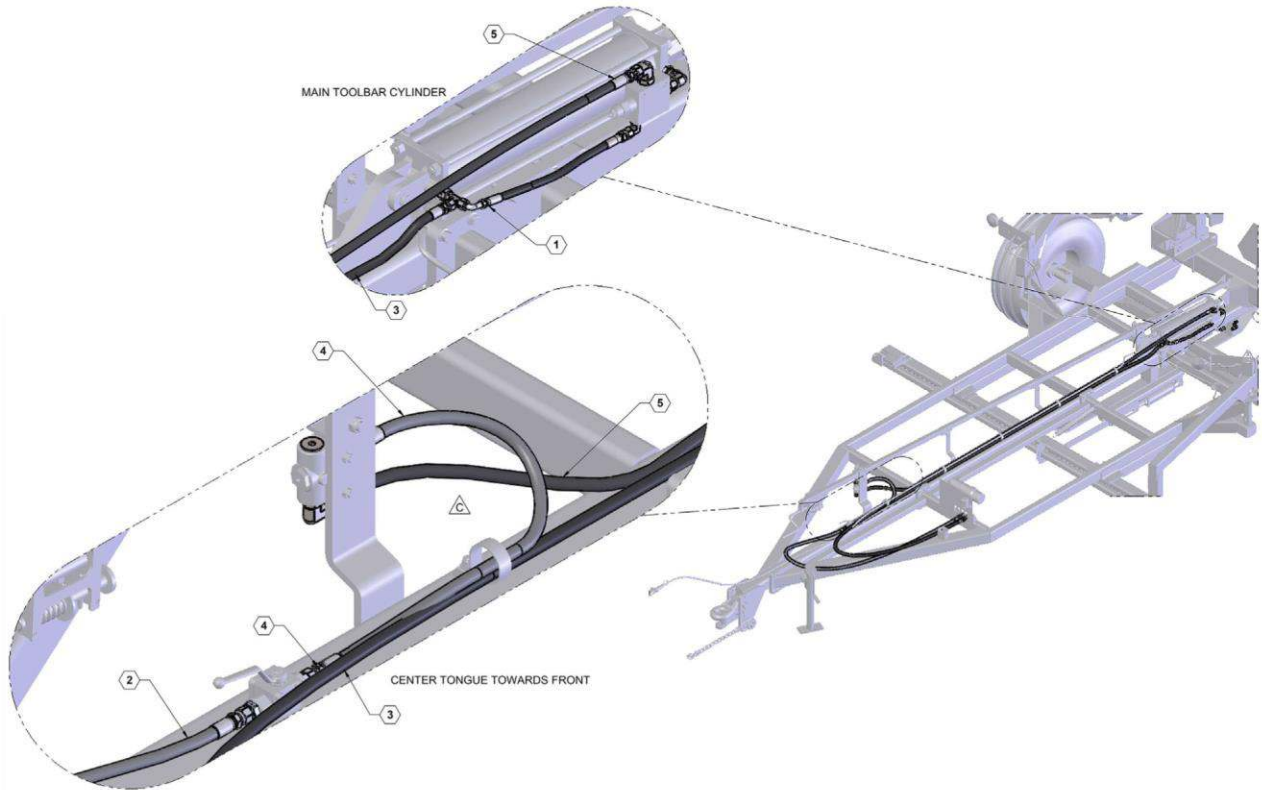



## Parts List 600113: Center Cylinder Hoses

ITEM	PART NO.	QTY.	DESCRIPTION
1	600113-4	1	HOSE ASSY, 04-6FJX90-6FJX-20
2	600113-7	1	HOSE ASSY, 06-6FJX-8MOR-89
3	600113-12	1	HOSE ASSY, 06-6FJX-8MOR-222.5
4	600113-13	1	HOSE ASSY, 06-6FJX-6FJX-32
5	600113-14	1	HOSE ASSY, 06-6FJX-8FJX-139.5

## Field Latch Hoses

FIELD LATCH PRESSURE: BLACK HOSE  
 FIELD LATCH RETURN: GRAY HOSE

FIELD LATCH HYDRAULIC LINES

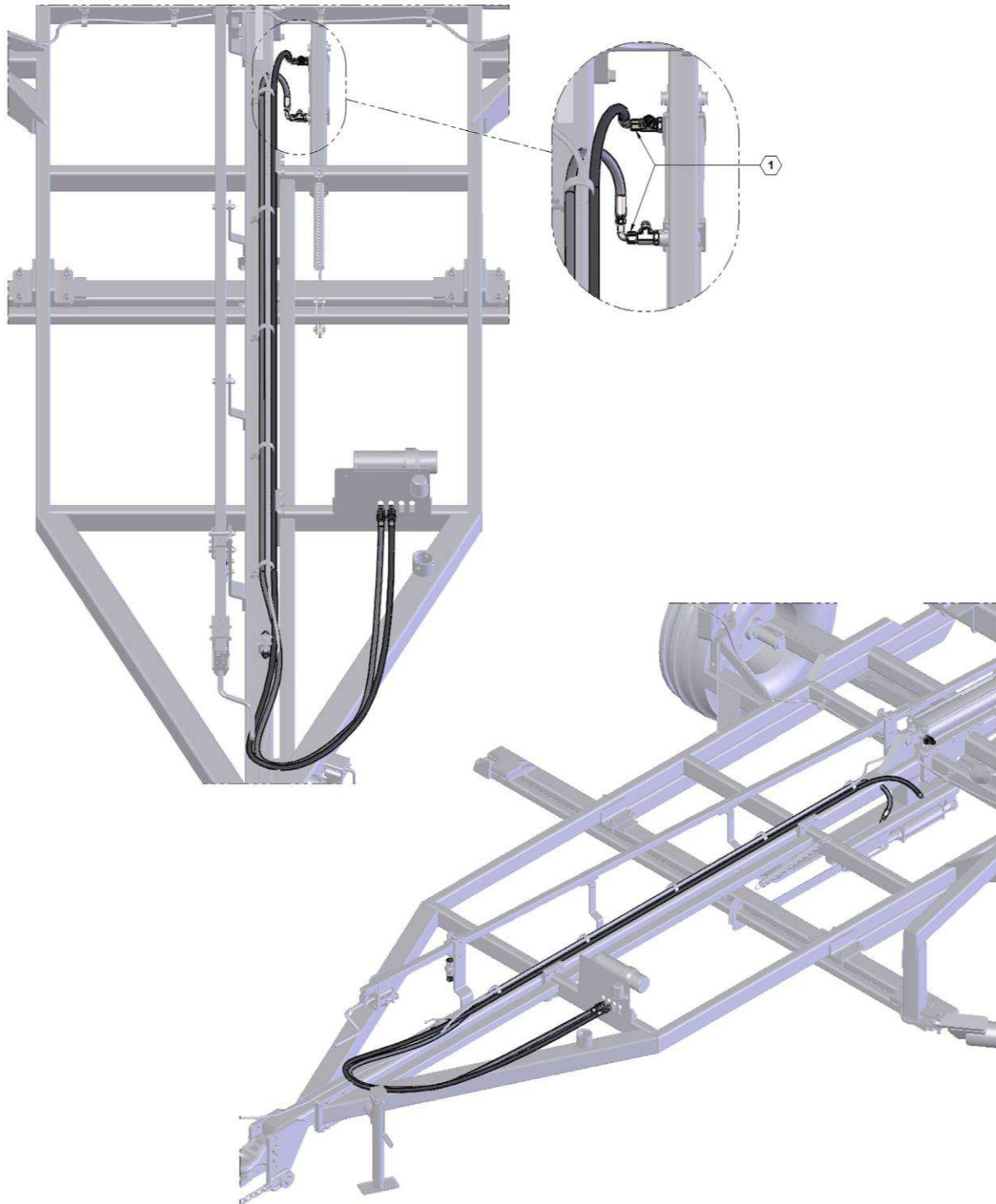

### Parts List: Field Latch Hoses

ITEM	PART NO.	QTY.	DESCRIPTION
1	600113-1	2	HOSE ASSY, 06-6FJX90-8MOR-220

## Gauge Wheel Cylinder Hoses

WING FOLD PRESSURE: BLACK HOSE  
 WING FOLD RETURN: GRAY HOSE

WING FOLD HYDRAULIC LINES

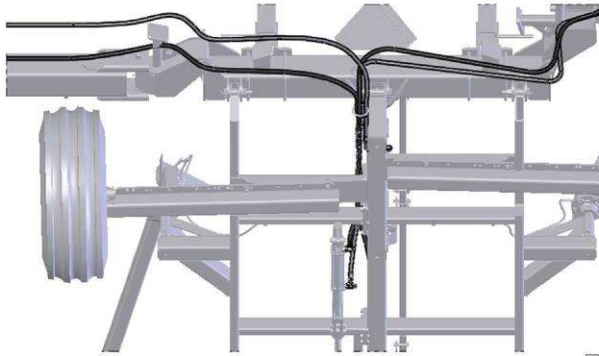

VIEW OF UNDERNEATH LOOKING FROM REAR

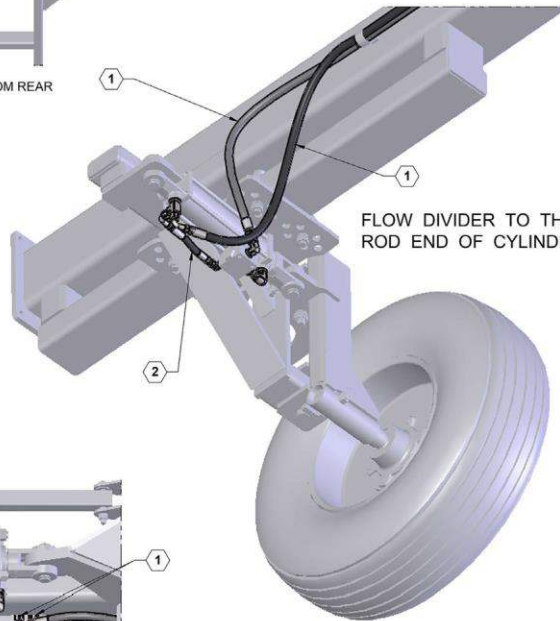

FLOW DIVIDER TO THE CHECK VALVE ON ROD END OF CYLINDER

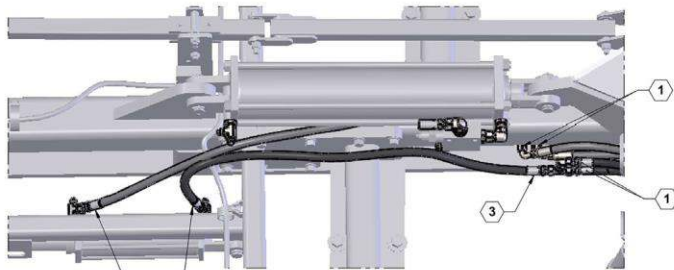

ROD END OF LATCH CYLINDER TO FLOW DIVIDER

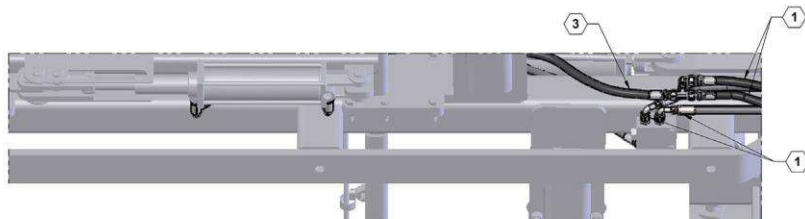

## Parts List: Gauge Wheel Cylinder Hoses

ITEM	PART NO.	QTY.	DESCRIPTION
1	600113-5	4	HOSE ASSY, 06-6FJX90-6FJX-319
2	600113-6	2	HOSE ASSY, 04-6FJX90-4FJX-8
3	600113-8	2	HOSE ASSY, 06-6FJX-6FJX-47

## Hydraulic Diagram

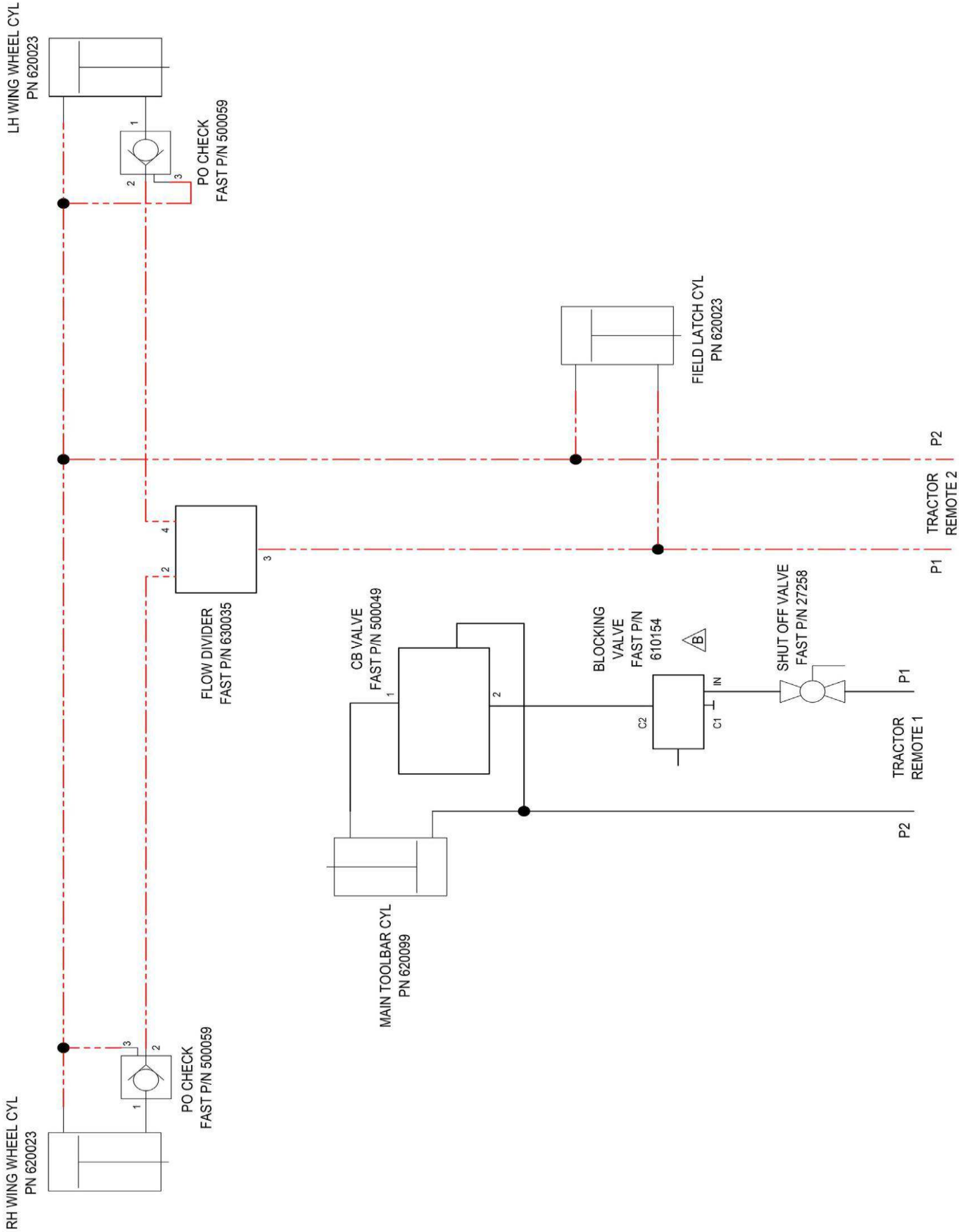

## Decals, 15 & 18 Meter Toolbar, Fast

**NOTE:**

1. DECALS ARE IN THE SAME LOCATIONS ON BOTH SIDES OF THE UNIT

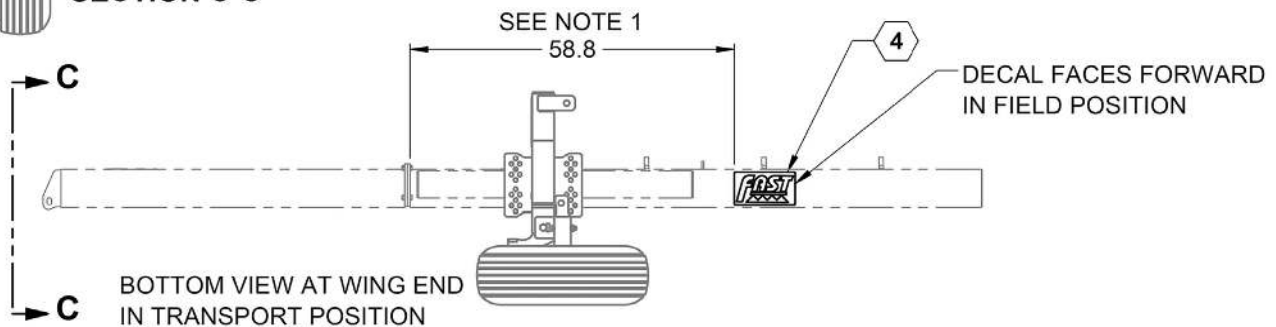
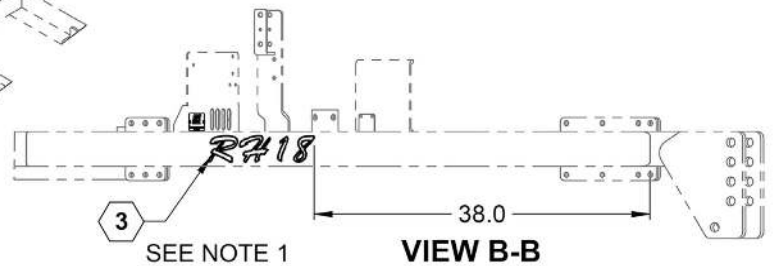
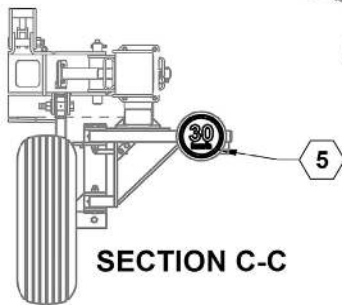
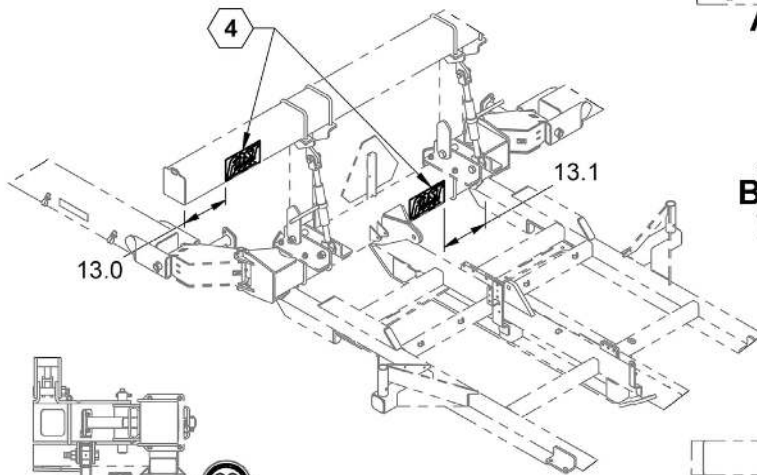
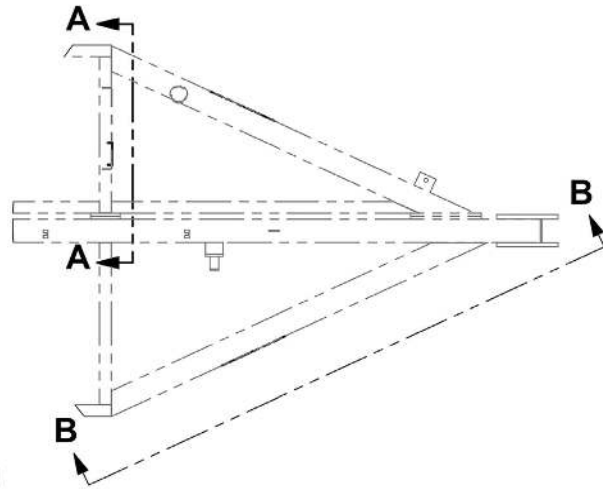
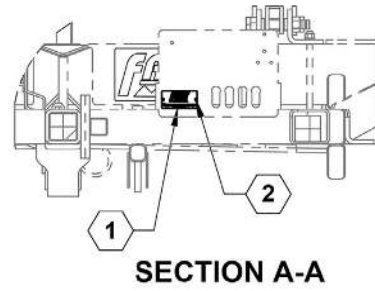
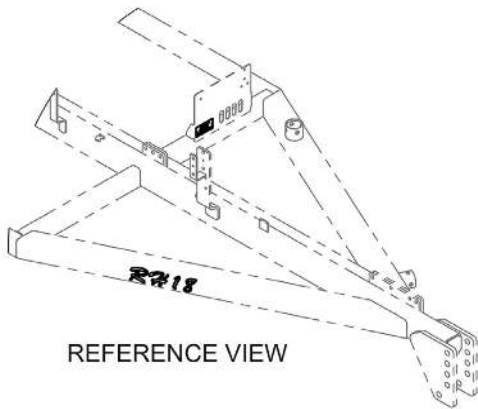





## ILLUSTRATED PARTS LIST

### Parts List: Decals, 15 & 18 Meter Toolbar, Fast

ITEM	PART NO.	QTY.	DESCRIPTION
1	590216	1	FAST SERIAL TAG
2	590341	2	RIVET, 1/8" STAINLESS
3	800270	2	DECAL, RH15 SILVER
3	800271	2	DECAL, RH18 SILVER
4	800272	4	DECAL, FAST LOGO BLK/GRY
5	800306	1	DECAL, SIS, 20 mile/h
5	800307	1	DECAL, SIS, 30 km/h

NOTES



Fast Ag Solutions, LLC  
4130 Commerce Boulevard  
Windom, MN 56101  
1-800-772-9279 Toll Free  
1-507-427-3861 Voice  
1-507-427-3030 Fax  
[www.fastagsolutions.com](http://www.fastagsolutions.com)