



# Liquid Fertilizer Applicator 8400

## Operation, Maintenance, & Parts Manual





2024-01-15



**TABLE OF CONTENTS**

FOREWORD.....1

SAFETY.....7

GENERAL INFORMATION AND OPERATING INSTRUCTIONS.....19

MAINTENANCE AND REPAIR.....53

ILLUSTRATED PARTS LISTS.....67

WARRANTY.....175

ALPHABETICAL INDEX.....179



**FOREWORD**

This Operation, Maintenance & Parts Manual was written to give the owner / operator instructions on the safe operation and maintenance of the FAST AG Solutions equipment.

READ AND UNDERSTAND THIS OPERATION, MAINTENANCE & PARTS MANUAL BEFORE OPERATING YOUR FAST AG SOLUTIONS EQUIPMENT.

**INTRODUCTION**.....3

    Safety Notice.....3

    Purpose.....3

    Scope.....3

    Terms.....3

    Modifications.....3

    Compliances.....3

**SERIAL NUMBER LOCATION**.....4

    Equipment Serial Number.....4

**FEATURES AND ACCESSORIES**.....5

    Standard Items.....5

    Optional Items.....5



## INTRODUCTION

Thank you for your decision to purchase a liquid fertilizer applicator from FAST AG Solutions. To ensure maximum performance of your equipment, it is mandatory that you thoroughly read and understand the Operation, Maintenance & Parts Manual and follow its recommendations. Proper operation and maintenance are essential to prevent injury or damage and to maximize equipment life.

Continuous improvement and advancement of FAST AG Solutions' products may result in changes to your equipment that may not be reflected in this publication. FAST AG Solutions reserves the right to make product improvements at any time. Although great care has been taken to ensure the accuracy of this publication, FAST AG Solutions does not assume any liability for errors or omissions.

### Safety Notice

Operate and maintain this equipment in a safe manner and in accordance with all applicable local, state, and federal codes, regulations and/or laws, and in compliance with on-product labeling and these instructions.

Make sure that all personnel have read this Operation, Maintenance & Parts Manual and thoroughly understand safe and correct operating and maintenance procedures.

### Equipment Purpose

The liquid fertilizer applicator is used to safely provide a means for liquid fertilizer to be properly applied to a field. The FAST AG Solutions Liquid Fertilizer Applicator has a hydraulic powered metering pump to send liquid chemicals or fertilizer to the distribution lines on the toolbar. Coulters open the soil to receive the liquid. Nozzles mounted to the toolbar spray the fluid into the soil.

### Scope Of The Document

This document outlines the specific design and performance requirements for the use of a FAST AG Solutions' liquid fertilizer applicator assembly. The word "must" in this document indicates a mandatory requirement. The use of "should" indicates a recommendation of that which is advised but not required.

## Terms

The terms of this equipment can be found in the warranty section of this manual. (See WARRANTY on Page 177.)

### Compliances

This FAST AG Solutions' equipment complies with the general Safety Standards specified by the American Society of Agricultural Engineers (ASAE) and the Occupational Safety and Health Administration (OSHA). Anyone who will be operating and/or maintaining the FAST AG Solutions Liquid Fertilizer Applicator must read and clearly understand ALL Safety, Operating and Maintenance information presented in this manual.

**Figure 1**

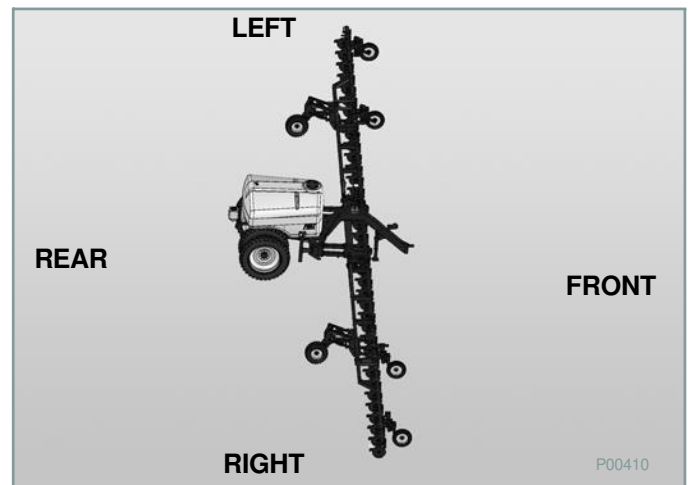

The directions left, right, front and rear, as mentioned throughout this manual, are as viewed from the rear of the equipment [Figure 1].

## SERIAL NUMBER LOCATION

### Equipment Serial Number

Figure 2

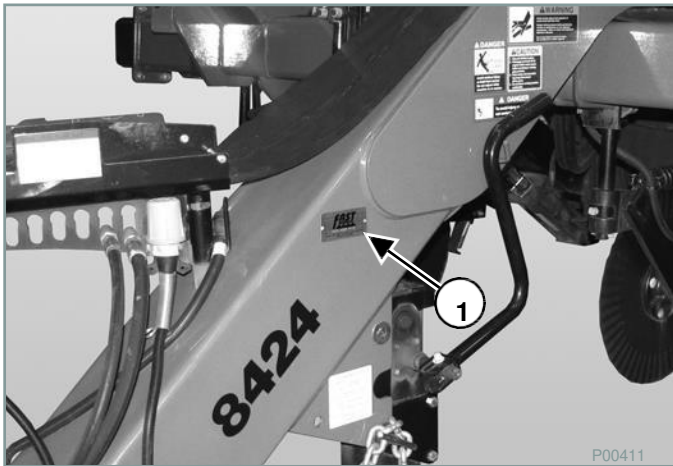

Model Number: \_\_\_\_\_

Serial Number: \_\_\_\_\_

The model number and serial number (Item 1) **[Figure 2]** is located on the left side of the hitch assembly. Always use the serial number of the equipment when requesting service information or when ordering parts. Early or later models (identification made by serial number) may use different parts, or it may be necessary to use a different procedure in doing a specific service operation.

## MANUFACTURER'S INFORMATION

FAST AG Solutions

4130 Commerce Boulevard

Windom, MN 56101

Phone 507-427-3861

Fax 507-427-3030

*Equipment Name:* Liquid Fertilizer Applicator (8400)

*Publication Number:* 996

*Publication Date:* 3-25-2020



---

## FEATURES AND ACCESSORIES

### Standard Items

The liquid fertilizer applicator assembly is equipped with the following standard items:

- Tall Gauge Wheels
- 380/90R46 Tires (1800 Gallon Tank)
- 380/90R46 Dual Tires (2400 Gallon Tank)
- 1850 or 2400 Main Gallon Tank
- Heavy Duty Jack
- Hydraulic Down Pressure
- Ace 205F-304 Pump

### Optional Items

The liquid fertilizer applicator assembly can be equipped with the following optional items:

- Dual Wheels (1800 Gallon Tank)
- Larger Tires
- Tracks\* - Camso 15 In. (381 mm) TTS Tracks
  - \* - For units equipped with track system, see vendor supplied documentation for Parts and Operational info.
- ISO Ready Connection
- Tall Gauge Wheel (Additional)
- FAST Coulters & Crop Defender
- Tank Agitation
- Pressure
- Bigger Flowmeter
- Ace 750 Oasis Pump
- Hypro Pump
- Pressure Transducer



**SAFETY**

**SAFETY PRECAUTIONS**.....9

    Safe Operation Is The Operator’s Responsibility.....9

    Use Safety Rules.....9

    Safe Operation Needs A Qualified Operator.....10

    Transportation Safety.....10

    Maintenance Safety.....11

**FIRE PREVENTION**.....11

    Maintenance.....11

    Electrical.....11

    Hydraulic System.....12

    Welding And Grinding .....12

    Fire Extinguishers.....12

**SIGN-OFF FORM**.....13

    Sign-Off Form.....13

**SAFETY IDENTIFICATION**.....14

    Decals.....14



**SAFETY PRECAUTIONS****Safe Operation Is The Operator's Responsibility**

	<b>Safety Alert Symbol</b>
<b>This symbol with a warning statement means: "Warning, be alert! Your safety is involved!" Carefully read the message that follows.</b>	

	<b>WARNING</b>
---	----------------

**Operator must have received instructions before operating this machine. Untrained operators can cause injury or death.**

W-2013-001

<b>IMPORTANT</b>
------------------

**This notice identifies procedures which must be followed to avoid damage to the machine.**

I-2013-001

	<b>DANGER</b>
---	---------------

**The signal word DANGER on the equipment and in the manuals indicates a hazardous situation which, if not avoided, will result in death or serious injury.**

D-2013-001

	<b>WARNING</b>
---	----------------

**The signal word WARNING on the equipment and in the manuals indicates a potentially hazardous situation which, if not avoided, could result in death or serious injury.**

W-2013-007

The FAST AG Solutions equipment must be in good operating condition before use.

**Use Safety Rules**

- Read and follow instructions on the equipment and in the equipment's Operation, Maintenance & Parts Manual before operating.
- In addition to the design and configuration of equipment, hazard control and accident prevention are dependent upon the awareness, concern, prudence and proper training of personnel involved in the operation, transport, maintenance and storage of equipment.
- Check that the equipment is securely fastened to the tractor (if required).
- Make sure all the equipment controls are in the NEUTRAL position before operating the equipment.
- Operate the equipment according to the Operation, Maintenance & Parts Manual.
- When learning to operate the equipment, do so at a slow rate in an area clear of bystanders.
- DO NOT permit additional personnel to be in the work area when operating the equipment.
- DO NOT modify equipment.
- DO NOT make any adjustments or repairs on the equipment while the engine is running.
- Keep shields and guards in place. Replace if damaged.

## SAFETY PRECAUTIONS (CONT'D)

### Safe Operation Needs A Qualified Operator

For an operator to be qualified, he or she must not use drugs or alcoholic drinks which impair alertness or coordination while working. An operator who is taking prescription drugs must get medical advice to determine if he or she can safely operate a machine and the equipment.

#### *A Qualified Operator Must Do The Following:*

- Understand the Written Instructions, Rules and Regulations.
- Understand the written instructions from FAST AG Solutions in this Operation, Maintenance & Parts Manual and machine signs (decals).
- Lower machine to ground, place all controls in neutral, stop engine, set park brake, remove ignition key, and wait for all moving parts to stop before servicing, adjusting, repairing or unplugging.
- Install and secure all guards and shields before starting or operating.
- Keep hands, feet, hair and clothing away from all moving and/or rotating parts.
- Do not allow riders on applicator or tractor during operation or when transporting.
- Clear area of all bystanders, especially children, before starting or filling with chemical or fertilizer.
- Read chemical or fertilizer manufacturers warnings, instructions and procedures **before** using and *follow them exactly*.
- Do not breathe, touch or ingest chemicals or fertilizer. Always wear protective clothing and follow safe handling procedures.
- Keep safe distance from wings when folding or extending wings. Keep others away.
- Clean reflectors, SMV (Slow Moving Vehicle) emblem and lights before transporting.
- Attach securely to towing unit using a hardened pin with a retainer and a safety chain.
- Do not exceed a safe travel speed.
- Use hazard flasher on tractor and applicator when transporting.

- Keep safe distance from overhead power lines when folding or extending wings and during transport.
- Before applying pressure to hydraulic system, make sure all components are tight; make sure hoses and couplings are in good condition.
- Review safety instructions annually.

### Transportation Safety

# IMPORTANT

**Verify main tank is empty before transporting on road.**

I-2015-017

- Read and understand ALL information in Operation, Maintenance & Parts Manual regarding procedures and SAFETY when operating applicator in field and/or on road.
- Check with local authorities regarding applicator transport on public roads. Obey all applicable laws and regulations.
- Always travel at a safe speed. Use caution when making corners or meeting traffic.
- Make sure the SMV emblem and all lights and reflectors that are required by the local highway and transport authorities are in place, are clean and can be seen clearly by all overtaking and oncoming traffic.
- Daybreak and dusk are particularly dangerous: pilot vehicles are recommended.
- Be sure applicator is properly connected to tractor and a retainer is used through towbar drawbar pin. Always attach a safety chain between frame and tractor.
- Keep right and yield right-of-way to allow faster traffic to pass. Drive on road shoulder, if permitted by law.
- Do not exceed 20 mph (32 km/h). Reduce speed on rough roads and surfaces.
- Always use hazard warning flashers on tractor when transporting unless prohibited by law.
- Keep safe distance from overhead power lines during transport. Electrocution can occur without direct contact.

**SAFETY PRECAUTIONS (CONT'D)****Maintenance Safety**

- Review Operation, Maintenance & Parts Manual and all safety items before working with, maintaining or operating applicator.
- Before servicing, adjusting, repairing or replacing:
  - Lower machine to ground
  - Place all controls in neutral
  - Stop engine
  - Set park brake
  - Remove ignition key
  - Wait for all moving parts to stop
- Follow good shop practices:
  - Keep service area clean and dry.
  - Be sure electrical outlets and tools are properly grounded.
  - Use adequate light for job at hand.
- Before applying pressure to a hydraulic system make sure all components are tight, hoses and couplings are in good condition.
- Relieve pressure from hydraulic circuit before servicing or disconnecting from tractor.
- Keep hands, feet, clothing and hair away from all moving and/or rotating parts.
- Clear area of bystanders, especially children, when carrying out any maintenance and repairs or making any adjustments or filling.
- Place stands or blocks under frame before working beneath machine or when changing tires.
- Be sure all guards are in place and secured when maintenance work is completed.
- Use only tools, jacks and hoists of sufficient capacity for the equipment weight and size and procedure.

**FIRE PREVENTION****Maintenance**

The equipment may have components that are at high temperatures under normal operating conditions. The primary source of high temperatures is the engine and exhaust system. The electrical system, if damaged or incorrectly maintained, can be a source of arcs or sparks.

Flammable debris must be removed regularly. If flammable debris is allowed to accumulate, it can cause a fire hazard.

All fuels, most lubricants and some coolant mixtures are flammable. Flammable fluids that are leaking or spilled onto hot surfaces or onto electrical components can cause a fire.

**Electrical**

Check all electrical wiring and connections for damage. Keep the battery terminals clean and tight. Repair or replace any damaged part or wires that are loose or frayed.

## FIRE PREVENTION (CONT'D)

### Hydraulic System

- Always place all tractor hydraulic controls in neutral before dismounting.
- Make sure that all components in hydraulic system are kept in good condition and are clean.
- Replace any worn, cut, flattened or crimped hoses.
- Do not attempt any makeshift repairs to hydraulic lines, fittings or hoses by using tape, clamps or cements. The hydraulic system operates under extremely high pressure. Inappropriate repairs will fail suddenly and create a hazardous and unsafe condition.
- Pressurized fluids can penetrate the skin. Hydraulic hoses can fail from age, damage and exposure. Do not search for hydraulic leaks without body and face protection. A tiny, almost invisible leak can penetrate the skin, thereby requiring immediate medical attention. Use wood or cardboard to detect hydraulic leaks, *never* use your hands.
- If injured by a concentrated high-pressure stream of hydraulic fluid, seek medical attention immediately. Serious infection or toxic reaction can develop from hydraulic fluid piercing skin surface.
- Before applying pressure to system; verify all components are tight, and that hoses and couplings are in good condition.

### Welding And Grinding

Always clean the equipment, disconnect the battery, and disconnect the wiring before welding. Cover rubber hoses, battery and all other flammable parts. Keep a fire extinguisher near the equipment when welding.

Have good ventilation when grinding or welding painted parts. Wear dust mask when grinding painted parts. Toxic dust or gas can be produced.

Dust generated from repairing nonmetallic parts can be flammable or explosive. Repair such components in a well-ventilated area away from open flames or sparks.

### Fire Extinguishers

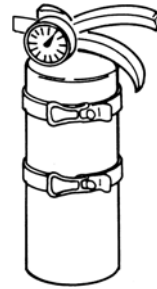

Know where fire extinguishers and first aid kits are located and how to use them. Inspect the fire extinguisher and service the fire extinguisher regularly. Obey the recommendations on the instructions plate.





# SAFETY IDENTIFICATION

## Decals

### Hitch Decal Locations

Figure 3

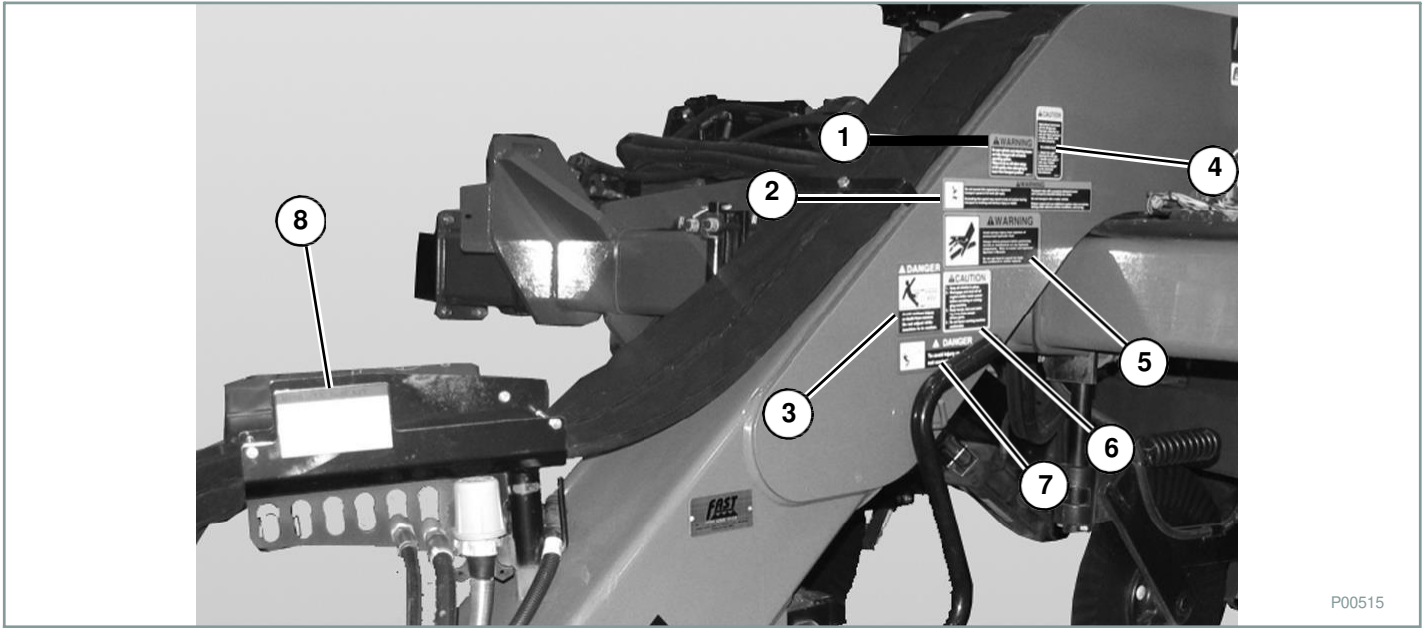

### Wing Decal Locations

Figure 4

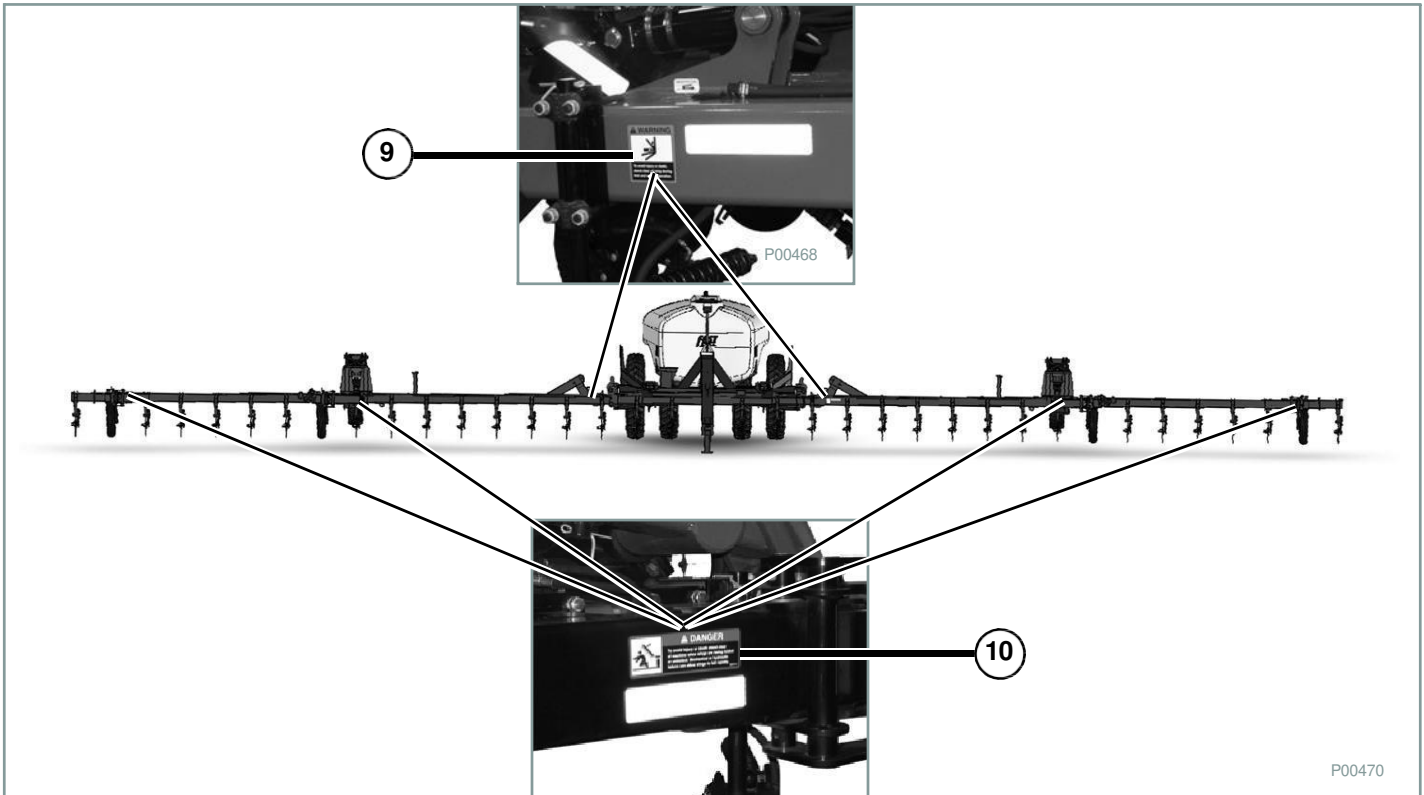

**SAFETY IDENTIFICATION (CONT'D)**

**Decals (Cont'd)**

*Rear Frame Decal Locations*

**Figure 5**

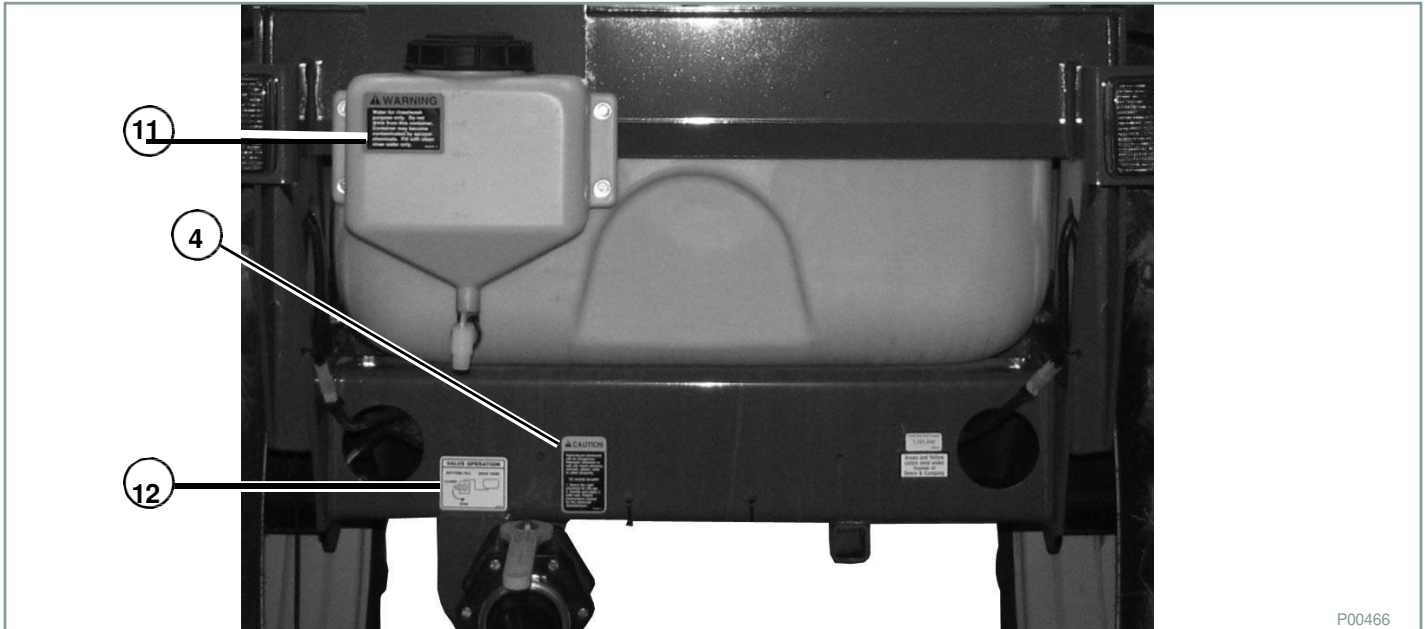

*Reflector Locations*

**Figure 6**

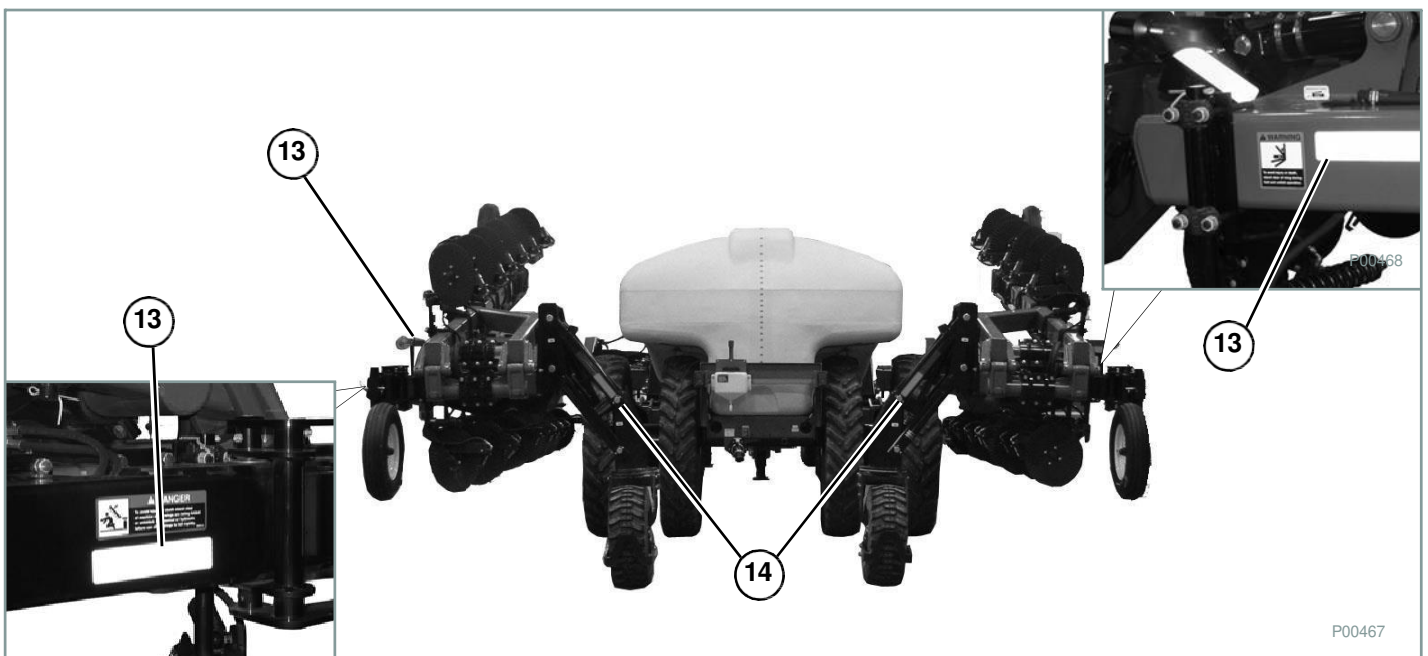

## SAFETY IDENTIFICATION (CONT'D)

### Decals (Cont'd)

Safety signs are used to alert the equipment operator or maintenance person to hazards and information that may be encountered in the use and maintenance of the equipment. The location and description of the safety signs are detailed in this section. Please become familiar with all safety signs installed on the machine /equipment.

A safety sign may contain more than one hazard panel and more than one avoidance panel.

**NOTE: See the numbered (See Decals on Page 14 and 15 for the location of each correspondingly numbered decal.**

#### 1. Hydraulic Hazard (800100)

This safety sign is located six places on the liquid fertilizer applicator (two places on the hitch and four places on the wings).



#### 2. Travel Hazard (800104)

This safety sign is located one place on the liquid fertilizer applicator hitch.



#### 3. Adjustment Hazard (800103)

This safety sign is located one place on the liquid fertilizer applicator hitch.



#### 4. Chemical Hazard (800101)

This safety sign is located two places on the liquid fertilizer applicator hitch and the rear frame.

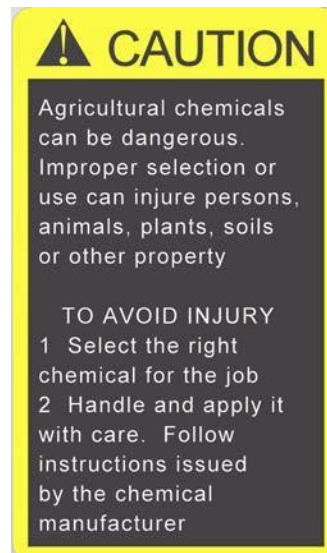

**SAFETY IDENTIFICATION (CONT'D)**

**Decals (Cont'd)**

**5. Hydraulic Hazard (800098)**

This safety sign is located in one place on the liquid fertilizer applicator hitch.



**6. Chemical Hazard (800100)**

This safety sign is located in one place on the liquid fertilizer applicator hitch.



**7. Electrical Hazard (800112)**

This safety sign is located in one place on the liquid fertilizer applicator hitch.



**8. Hydraulic Hose Identification (800087)**

This safety sign is located one place on the liquid fertilizer applicator hitch.

HYDRAULIC HOSE KEY	
COLOR	DESCRIPTION OF USE
Red	Pump Pressure
Yellow	Pump Return
Grey	Main Lift \ Wing Kick Pressure (Raise)
Orange	Main Lift \ Wing Kick Return (Lower) - Run in Constant Flow
Purple	Hydraulic Block Pressure
Brown	Hydraulic Block Return

**9. Crush Hazard (800105)**

This safety sign is located two places on the liquid fertilizer applicator wings.

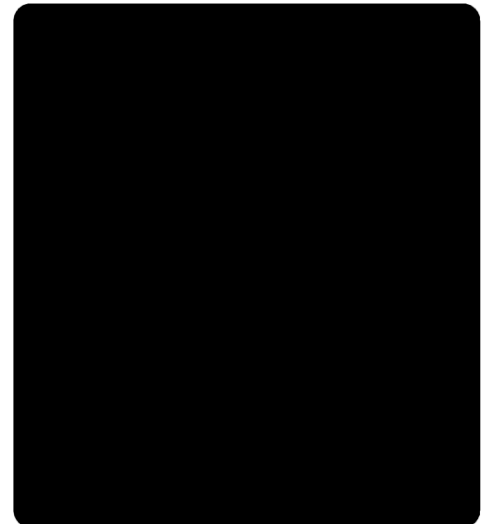

## SAFETY IDENTIFICATION (CONT'D)

### Decals (Cont'd)

#### 10. Crush Hazard (800106)

This safety sign is located four places on the liquid fertilizer applicator wings.



#### 11. Rinse Water Hazard (800108)

This safety sign is located in one place on the liquid fertilizer fresh water tank.

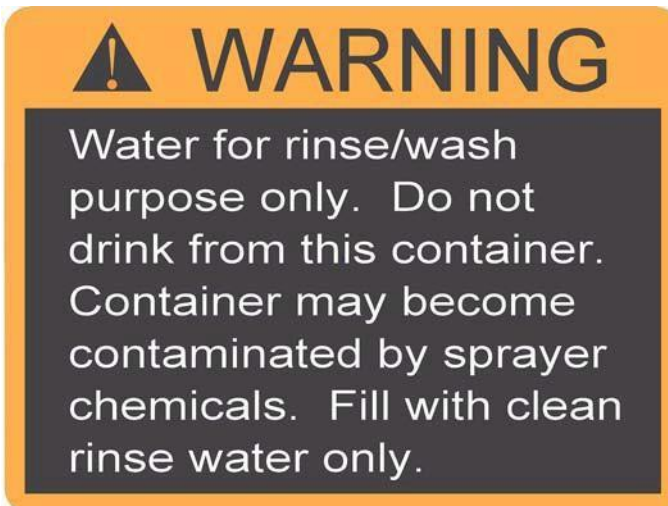

#### 12. Operating (800017)

This safety sign is located in one place on the liquid fertilizer applicator frame.

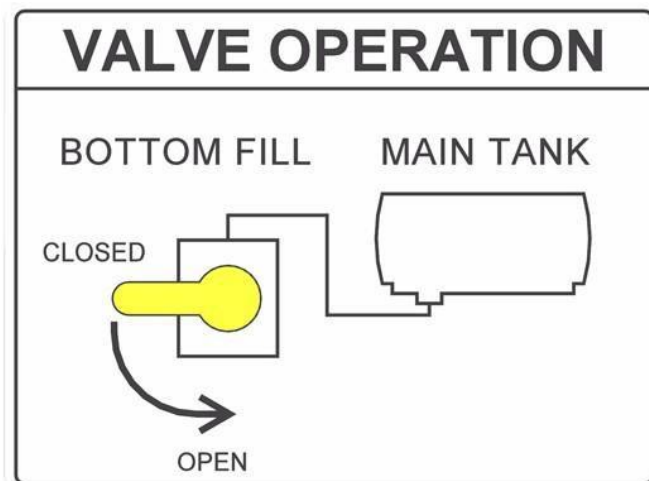

#### 13. Reflector (800110)

This safety sign is located in two places on the liquid fertilizer applicator frame.



#### 14. Reflector (800111)

This safety sign is located in two places on the liquid fertilizer applicator frame.



**GENERAL INFORMATION AND OPERATING INSTRUCTIONS**

**GENERAL INFORMATION AND OPERATING INSTRUCTION SAFETY PRECAUTIONS**.....21

**PURPOSE OF EQUIPMENT**.....24

**GENERAL DESCRIPTION**.....24

**MAJOR COMPONENTS**.....25

**EQUIPMENT SPECIFICATIONS**.....26

Dimensions.....26

Performance.....27

**PRE-OPERATION SETUP**.....28

Initial Operation Checklist.....28

Pre-Operation Checklist.....28

    Tractor Requirements.....29

Entering And Exiting Operator’s Position.....30

Connecting The Fertilizer Applicator To The Tractor.....30

Connecting Hydraulic Hoses And Electrical Connections.....32

Controls Description.....33

Leveling The Liquid Fertilizer Applicator.....34

Unfold And Fold Toolbar.....35

Tool Bar Raise / Lower Adjustments.....39

Adjust Coulter Depth.....41

System Screen.....42

**FIELD OPERATION**.....43

**POST-OPERATION DISCONNECTION**.....48

**TRANSPORTATION**.....49

**STORAGE INSTRUCTIONS**.....51

Storage.....51

Re-Commissioning.....51





## GENERAL INFORMATION AND OPERATING INSTRUCTION SAFETY PRECAUTIONS

### **DANGER**

#### ELECTROCUTION HAZARD

To prevent serious injury or death from electrocution:

- Be aware of overhead powerlines.
- Keep away from powerlines when transporting or folding or unfolding wings.
- Electrocution can occur without direct contact.

D-2015-004

### **DANGER**

#### CRUSH HAZARD

To avoid serious injury or death, keep everyone clear of machine when folding or extending wings.

D-2015-005

### **DANGER**



#### CHEMICAL HAZARD

To prevent serious injury or death:

##### WEAR PERSONAL PROTECTIVE EQUIPMENT

- Do not allow chemicals or solution to touch skin.
- Some chemicals can be absorbed through the skin.
- Wear rubber gloves and protective gear at all times.

##### DON'T BREATHE VAPOR

- Avoid chemical splash and vapor. Keep others away.
- Do not breathe vapor.
- Wear proper respirator when working with chemicals.
- Chemicals can be toxic.

##### DON'T INGEST CHEMICAL

- If in eyes or mouth, read manufacturer's instructions and follow them exactly.
- Seek immediate medical attention.
- Before working with chemicals, know the poison control phone number for your location.

D-2015-006

### **WARNING**



#### CRUSHING HAZARD

- Before moving the tractor / equipment, look in all directions and make sure no bystanders are in the work area.
- Do not allow anyone between the tractor and the equipment when backing up to the equipment for connecting.

W-2014-005

GENERAL INFORMATION AND OPERATING  
INSTRUCTION SAFETY PRECAUTIONS (CONT'D)

 **WARNING**



**CRUSHING HAZARD**

Keep fingers and hands out of pinch points when connecting and disconnecting equipment.

W-2014-002

---

 **WARNING**

**AVOID INJURY OR DEATH**

Use of an unapproved hitch or tow vehicle can result in loss of control, leading to serious injury or death. Tractor and hitch must have the rated capacity to tow this equipment.

W-2014-004

---

 **WARNING**

Verify that the equipment is securely fastened to the tractor before moving the tractor and equipment.

W-2014-006

---

 **WARNING**

**AVOID INJURY OR DEATH**

Pay attention to surrounding areas to prevent being crushed between two pieces of equipment.

W-2013-020

---

 **WARNING**

**AVOID INJURY OR DEATH**

Install and secure all guards and shields before starting or operating.

W-2015-019

---

 **WARNING**

**AVOID INJURY OR DEATH**

Do not allow riders on the applicator or tractor during operation or transporting.

W-2015-021

---

 **WARNING**

**AVOID INJURY OR DEATH**

Clear area of all bystanders, especially children, before starting or filling with chemical or fertilizer.

W-2015-022

---

 **WARNING**

**AVOID INJURY OR DEATH**

Do not breathe, touch or ingest chemicals or fertilizer. Always wear protective clothing and follow safe handling procedures.

W-2015-024

---

## GENERAL INFORMATION AND OPERATING INSTRUCTION SAFETY PRECAUTIONS (CONT'D)

### **WARNING**

#### **AVOID INJURY OR DEATH**

Read chemical or fertilizer manufacturers warnings, instructions and procedures before starting and follow them exactly.

W-2015-023

---

### **WARNING**

#### **AVOID INJURY OR DEATH**

Stay away from wings when folding or extending wings. Keep others away.

W-2015-025

---

### **WARNING**

#### **AVOID INJURY OR DEATH**

Do not exceed a safe travel speed.

W-2015-026

---

### **WARNING**

#### **AVOID INJURY OR DEATH**

Stay away from overhead power lines when folding or extending the wings and during transport.

W-2015-027

---

### **WARNING**

#### **AVOID SERIOUS INJURY OR DEATH**

Do not spill chemicals on skin or clothing. If chemicals are spilled, remove contaminated clothing immediately and wash skin (and clothing) thoroughly with soap and water. Wash hands and face with soap and water and change clothing after spraying.

W-2015-034

---

### **WARNING**

#### **AVOID SERIOUS INJURY OR DEATH**

Always read the label before using chemicals. Follow the instructions from the chemical manufacturer on how to select, use and handle each chemical. Note protection information each time before opening the container.

W-2015-035

---

### **IMPORTANT**

Clean reflectors, SMV emblem and lights before transporting.

I-2015-014

---

### **IMPORTANT**

Attach securely to towing unit using a hardened pin with a retainer and a safety chain.

I-2015-015

---

## IMPORTANT

Use hazard flasher on tractor when transporting.

I-2015-016

## IMPORTANT

Verify main tank is empty before transporting on road.

I-2015-017

## PURPOSE OF EQUIPMENT

The FAST AG Solutions Liquid Fertilizer Applicator is used to safely provide a means for liquid fertilizer to be properly applied to a field. The FAST AG Solutions Liquid Fertilizer Applicator has a hydraulic powered pump to send liquid chemicals or fertilizer to the control section (Flow Meter and MCV (Motorized Control Valve)). From the control section, product flows through the ball valve to the distribution lines on the toolbar. Coulters open the soil to receive the liquid. Nozzles/Knives mounted to the toolbar spray/inject the fluid into the soil.

## GENERAL DESCRIPTION

For more information on:

- Major Components (*See Page 25*).
- Dimensions (*See Page 26*).
- Performance (*See Page 27*).

## MAJOR COMPONENTS

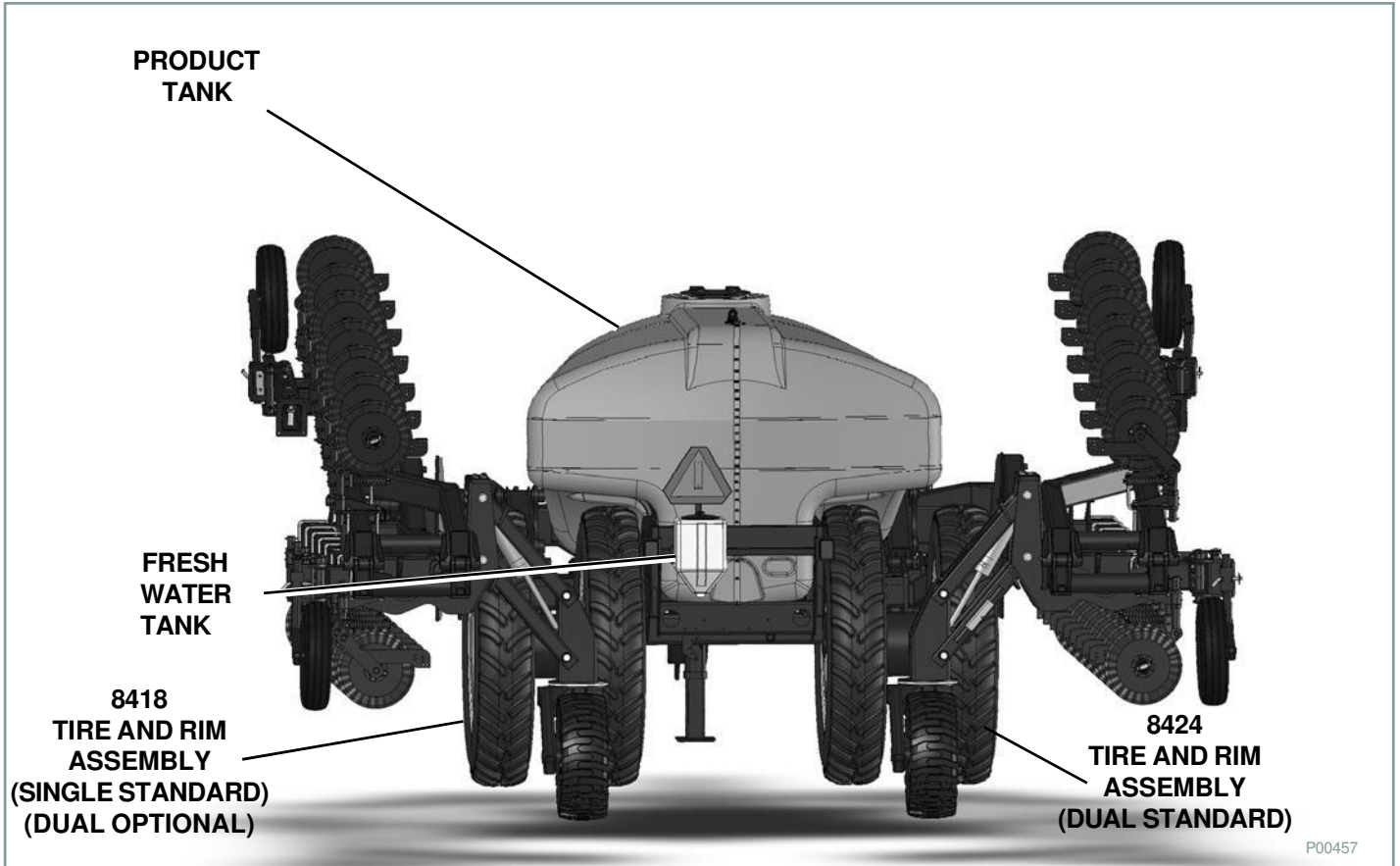
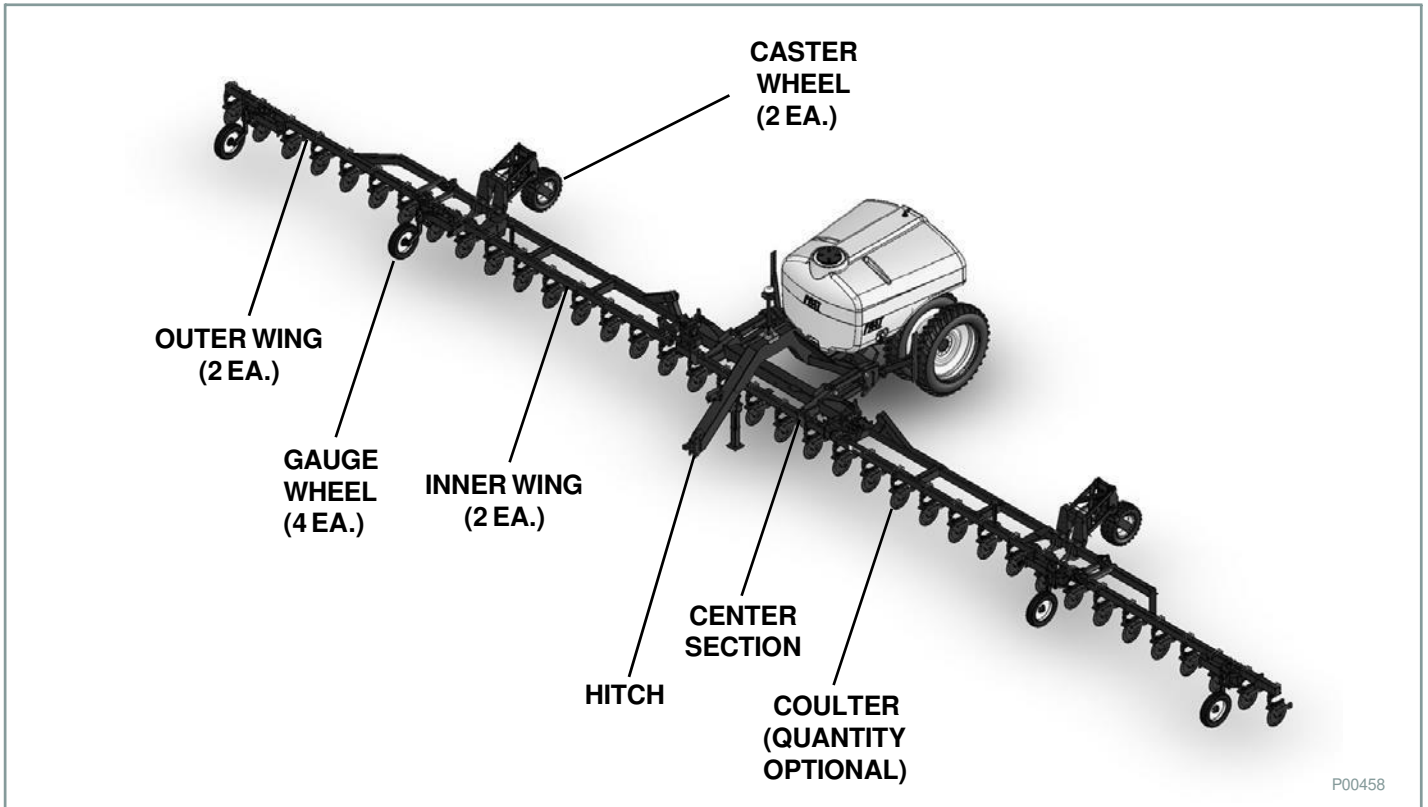

## EQUIPMENT SPECIFICATIONS

### Dimensions

- Where applicable, specifications conform to **SAE and ISO** standards and are subject to change without notice.

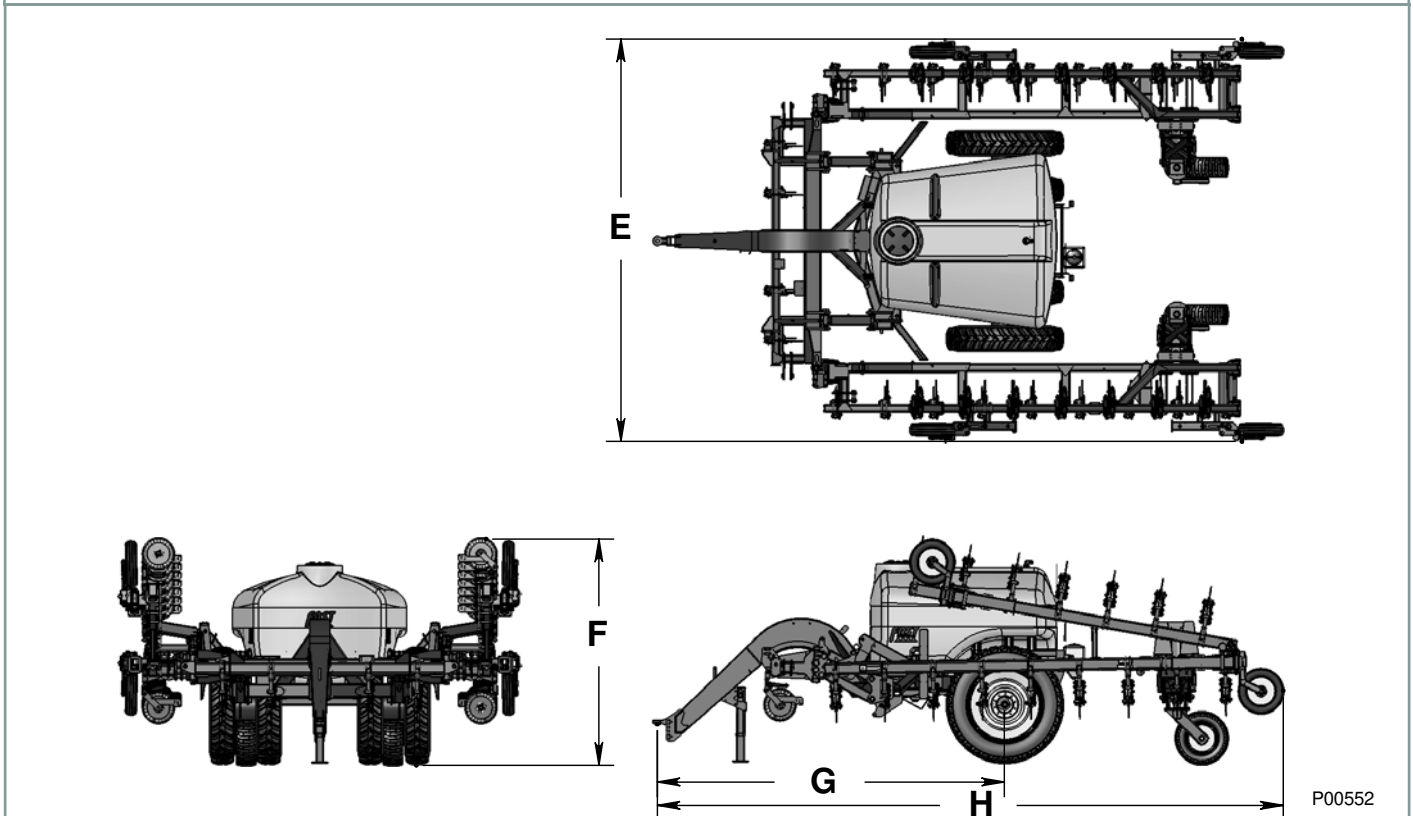
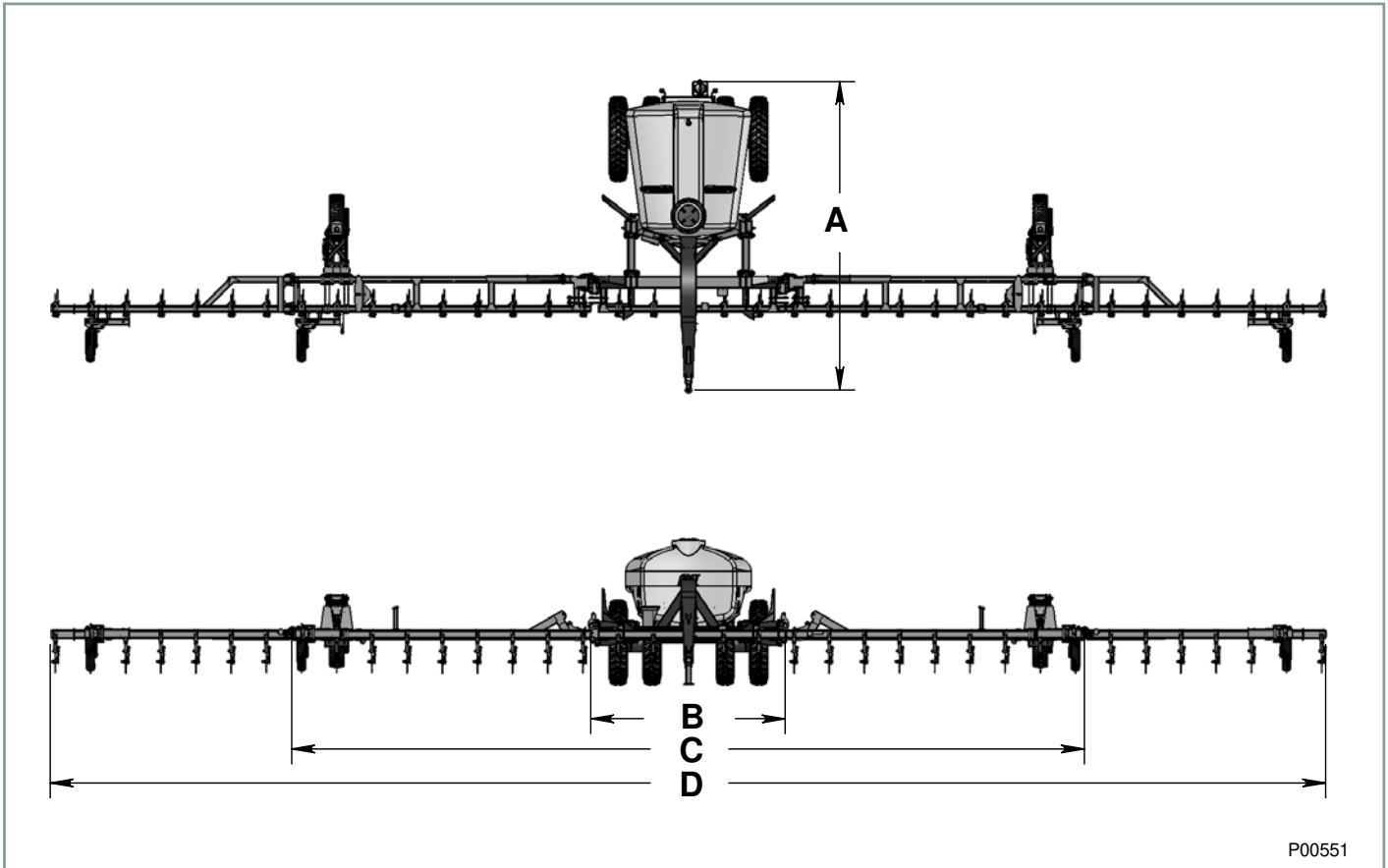



# GENERAL INFORMATION AND OPERATING INSTRUCTIONS

## EQUIPMENT SPECIFICATIONS (CONT'D)

### Dimensions (Cont'd)

DESCRIPTION	MODEL 8400
Length, Unfolded (A)	21 ft. 0 in. (6401 mm)
Width, Center Section (B)	13 ft. 10 in. (4216 mm)
Width, Inner Wings Unfolded (C)	56 ft. 2 in. (17120 mm)
Width, Outer Wings Unfolded 80 ft (D)	80 ft. 5 in. (24536 mm)
Width, Outer Wings Unfolded 90 ft (D)	90 ft. 5 in. (27559 mm)
Width, Wings Folded (E)	18 ft. 3 in. (5563 mm)
Height, Wings Folded (F)	12 ft. 5 in. (3785 mm)
Length, Hitch To Center Of Tire (G)	17 ft. 9 in. (5410 mm)
Length, Wings Folded (H)	29 ft. 5 in. (8966 mm)

### Performance

DESCRIPTION	MODEL 8400
Tractor Horse Power Requirement	80 ft (2438 cm) 240 hp 90 ft (2732 cm) 260 hp
Weight	24000 lb. (10886.2 kg)
Capacity	1850 gal (7003 l) or 2400 gal (9085 l)
Tow Speed (Maximum)	* 20 mph (32 kmh)
	** 10 mph (16 kmh)
	*** DO NOT TOW

\* - Weight of fully equipped liquid fertilizer applicator equal to or less than the weight of towing machine.

\*\* - Weight of fully equipped liquid fertilizer applicator is two times or less than the weight of towing machine.

\*\*\* - Weight of fully equipped liquid fertilizer applicator more than two times the weight of towing machine.

<b>IMPORTANT</b>	<p><b>PREVENT EQUIPMENT DAMAGE.</b></p> <p>Verify main tank is empty before transporting on road.</p>
------------------	---

I-2015-025

## PRE-OPERATION SETUP

### Initial Operation Checklist

**NOTE: Perform the following steps when using a new applicator.**

#### *After First Hour Of Operation*

- Tighten all wheel lug nuts to 265 ft-lb (359.30 N-m) of torque.
- Tighten caster lug bolts to 90 ft-lb (122 N-m) of torque.
- Tighten all other fasteners and hardware to required torque.
- Check that no chemical or hydraulic lines are being pinched or crimped. Re-route as required.
- Check that all coulters, nozzles and placement components are clean and working properly. Clean as required.
- Check that metering pump is functioning properly. Adjust as required.
- Lubricate all grease fittings. (See *PREVENTATIVE MAINTENANCE on Page 55.*)

#### *After Five Hours Of Operation*

- Tighten all wheel lug nuts to 265 ft-lb (359.30 N-m) of torque.
- Tighten caster lug bolts to 90 ft-lb (122 N-m) of torque.

#### *After 10 hours of operation*

- Tighten all wheel lug nuts to 265 ft-lb (359.30 N-m) of torque.
- Tighten caster lug bolts to 90 ft-lb (122 N-m) of torque.
- Tighten all fasteners and hardware to required torque.
- Check chemical and hydraulic line routing.
- Check that all placement components are clean and working properly.

#### *After 50 hours of operation*

- Tighten all wheel lug nuts to 265 ft-lb (359.30 N-m) of torque.
- Tighten caster lug bolts to 90 ft-lb (122 N-m) of torque.
- Perform normal servicing and maintenance. (See *PREVENTATIVE MAINTENANCE on Page 55.*)

## Pre-Operation Checklist

**NOTE: Efficient and safe operation of the FAST AG Solutions Liquid Fertilizer Applicator requires that each operator reads and understands operating procedures and all related safety precautions outlined in this section. A pre-operational checklist is provided for the operator. It is important for both personal safety and maintaining good mechanical condition of the applicator that this checklist be followed.**

Before operating applicator, check the following items:

- Use only a tractor of adequate power and weight to operate applicator. (See *Performance on Page 27.*)
- Lubricate all grease fittings. (See *PREVENTATIVE MAINTENANCE on Page 55.*)
- Be sure that machine is properly attached to tractor. Be sure that a mechanical retainer is installed through drawbar pin and safety chain is installed.
- Inspect all hydraulic lines, hoses, fittings and couplers for tightness.
- Check tires and verify they are inflated to specified pressure.
- Calibrate applicator at start of season or a new applicator rate is being used.
- Check condition and routing of all fluid hoses and lines. Be sure that all lines are routed in large arcs. Replace any that are damaged. Re-route those that are rubbing, pinched or crimped.
- Check placement components. Remove and replace any that are worn.
- Remove all entangled material.
- Raise toolbar slightly/turn on metering pump slightly. Check that there is liquid coming out of each nozzle. Unplug or connect lines as required. Replace any nozzles that are plugged.



## PRE-OPERATION SETUP (CONT'D)

### Tractor Requirements

**NOTE:** To ensure the safe and reliable operation of the applicator, it is necessary to use a tractor with appropriate specifications.

Confirm the following requirements are met:

**Tractor Horsepower:** Refer to "Performance" page 27.

**NOTE:** Although recommended tractor horsepower is not required to pull machine, it does provide required strength on drawbar as hitch is very heavy. This will also insure that the unit has the required stability and control in hilly terrain and during transport.

**Front End Weights:** It is also recommended that each tractor be equipped with full suitcase weights on front of tractor. This will provide the required weight on front for turning and extra traction if equipped with front wheel assist.

**Hydraulic System:** Tractor hydraulic system must have a flow of 13 gpm (59 lpm) at 2950 psi (20340 kPa) to operate lift cylinders and drive motor.

**NOTE:** Either closed-centered or open-centered systems can be used.

**NOTE:** Contact FAST AG Solutions for optional flow control for use with high flow open-center system.

**Remote Outlets:** Three remote outlets are required:

- Toolbar lift cylinders and wing kick.  
Remote 1 - Set to main flow.
- Inner wing extend/fold cylinders and outer wing extend/ fold cylinders.  
Remote 2 - Set to 5 gpm (19 lpm).
- Chemical/fertilizer pump drive motor.  
Remote 3 - Set as required.

## IMPORTANT

### TO PREVENT DAMAGE TO LINKAGES AND CYLINDERS

**Always place tractor hydraulic control lever in detent to provide a constant flow of oil to the down pressure system.**

**If operating in very soft conditions and down pressure is not wanted, place lever in "float" to allow cylinder to extend or retract as necessary by ground conditions.**

I-2016-004

**NOTE:** Always place tractor's hydraulic control lever in detent to provide a constant flow of oil to pump drive motor. (See the tractor's Operation & Maintenance manual.)

## PRE-OPERATION SETUP (CONT'D)

### Entering And Exiting Operator's Position

# IMPORTANT

Follow the instructions in your tractor's operation manual for the correct procedure.

I-2015-018

#### *Entering The Operator's Position*

Move to the operator's position, start the engine and release the parking brake.

#### *Leaving The Operator's Position*

# WARNING

## AVOID INJURY OR DEATH

Before you leave the operator's position:

- Always park on a flat level surface.
- Place all controls in NEUTRAL.
- Engage the park brake.
- Stop the engine and remove the key.
- Wait for all moving parts to stop.

W-2015-028

Park the tractor / equipment on a flat level surface.

Place all controls in neutral, engage the park brake, stop the engine and wait for all moving parts to stop. Leave the operator's position.

### Connecting The Fertilizer Applicator To The Tractor

Inspect the tractor's drawbar and fertilizer applicator hitch before connecting. See the tractor's owner's manual.

Enter the operator's position. (*See Entering And Exiting Operator's Position on this page.*)

Move the tractor into position in front of the fertilizer applicator.

# WARNING

## AVOID INJURY OR DEATH

Before moving the tractor, look in all directions and make sure no bystanders, especially small children, are in the work area. Do not allow anyone between the tractor and the equipment when backing up to the equipment for connecting.

W-2015-029

Move the tractor backwards, aligning the drawbar with the fertilizer applicator's hitch.

**NOTE: The jack may need to be lowered or raised for proper alignment of the drawbar and hitch.**

If the fertilizer applicator's hitch needs to be adjusted, stop the tractor when drawbar is just in front of the fertilizer applicator's hitch.

Leave the operator's position. (*See Entering And Exiting Operator's Position on this page.*)

## PRE-OPERATION SETUP (CONT'D)

### Connecting The Fertilizer Applicator To The Tractor (Cont'd)

Figure 7

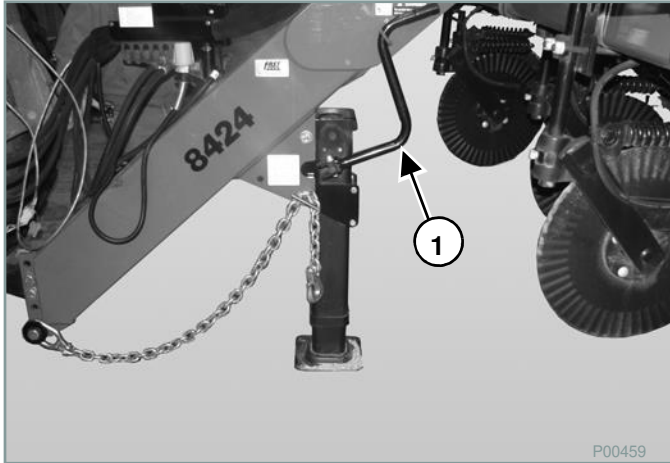

Turn the jack handle (Item 1) **[Figure 7]** clockwise to raise the hitch or counterclockwise to lower the hitch.

Lower or raise the fertilizer applicator hitch until aligned with the tractor's drawbar.

Move to the operator's seat, start the engine and release the parking brake. (See *Entering And Exiting Operator's Position on Page 30.*)

Move the tractor backwards, aligning the drawbar hitch pin hole with the fertilizer applicator hitch pin hole(s).

Stop the tractor and leave operator's position. (See *Entering And Exiting Operator's Position on Page 30.*)



### CRUSHING HAZARD

Keep fingers and hands out of pinch points when connecting and disconnecting equipment.

W-2014-002

**NOTE:** Always use a hitch pin of adequate size and strength and a retaining pin with a locking device.

Figure 8

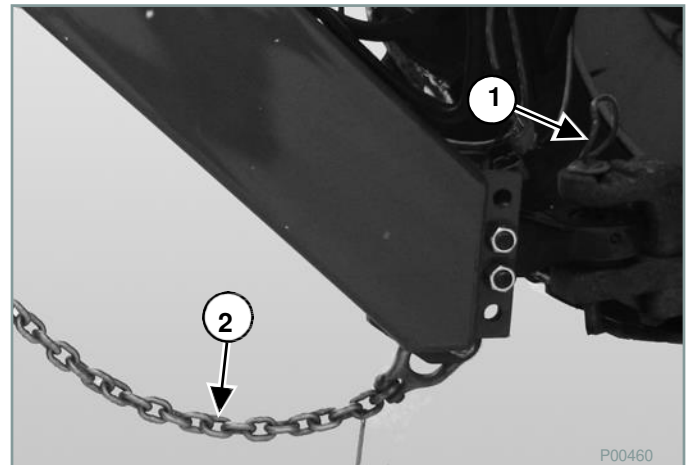

Install the hitch pin (Item 1) **[Figure 8]** and retaining pin to securely fasten the fertilizer applicator hitch to the tractor drawbar.

Attach the safety chain (Item 2) **[Figure 8]** around the drawbar.

Turn the jack handle (Item 1) **[Figure 7]** counterclockwise to lower the hitch. Place jack in the stowed position.

## PRE-OPERATION SETUP (CONT'D)

### Connecting Hydraulic Hoses And Electrical Connections

# ! WARNING

#### HIGH PRESSURE FLUID HAZARD

To prevent serious injury or death from high pressure fluid:

- Relieve pressure on system before repairing or adjusting.
- Wear proper hand and eye protection when searching for leaks. Use wood or cardboard instead of hands.
- Keep all components in good repair.

W-2015-030

# IMPORTANT

Fluid such as engine oil, hydraulic fluid, coolants, grease, etc. must be disposed of in an environmentally safe manner. Some regulations require that certain spills and leaks on the ground must be cleaned in a specific manner. See local, state and federal regulations for the correct disposal.

I-2015-009

**NOTE:** Make sure the quick couplers are fully engaged. If the quick couplers do not fully engage, check to see that the couplers are the same size and type.

**NOTE:** Hydraulic hose(s) are marked with colored zip ties. (See chart on this page for usage.)

Figure 9

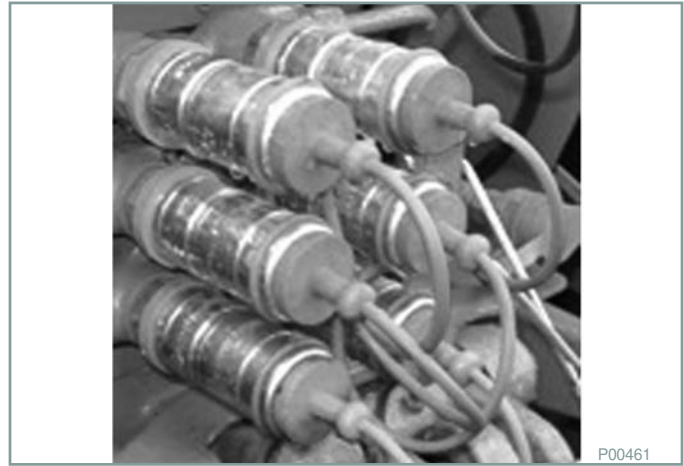

Push male couplers into female couplers on the tractor until they are fully engaged and locked [Figure 9]. Use the chart below for hydraulic hose placement. (See the tractor's Operation And Maintenance manual.)

COLOR	HOSE DESCRIPTION	REMOTE
Red	Pump Pressure	3
Yellow	Pump Return	3
Grey*	Main Lift/Wing Kick Pressure (Raise)	1
Orange	Main Lift/Wing Kick Return (Lower)	1
Purple	Hydraulic Block Pressure	2
Brown	Hydraulic Block Return	2

\* - Run in constant flow.

Route electrical lines over hitch and connect to tractor's electrical connectors.

**NOTE:** Be sure to provide slack for turning.

# REGULATING HYDRAULIC FLOW TO THE SPRAYER PUMP

Locate your tractor model and follow the appropriate setup instructions.

**WARNING:** FAILURE TO REGULATE OIL FLOW WILL CAUSE MOTOR FAILURE.

**WARNING:** NOT SUITABLE FOR PUMPING FLAMMABLE LIQUIDS.

## LOAD SENSING CLOSED CENTER SYSTEM (LS CLOSED)

Regulate oil flow with tractor's **FLOW CONTROL** and **FLOW LIMITER**.

(Do not use restrictor orifice.)

### Setup Instructions:

1. (Optional) Remove adapter and install flow limiter in motor inlet port (marked **I**).
2. Close motor needle valve: loosen jam nut, screw needle valve clockwise until seated, and lock jam nut. (factory setting)
3. Shut off sprayer boom and agitation valves.
4. Adjust tractor flow control to minimum flow setting (turtle).
5. Move hydraulic lever to "Lower/Retract" position to start pump.
6. Adjust tractor flow control until sprayer shut-off pressure is below maximum shown in table on page 3.

Note: If the flow limiter stops oil flow to the motor:

- 6a) Move hydraulic lever to "Float" or "Neutral" to remove oil pressure from the flow limiter.
  - 6b) Adjust tractor flow control to a lower flow position.
  - 6c) Repeat steps 5 and 6.
7. Open the sprayer agitation valve to get desired spraying pressure.

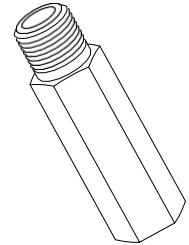

FLOW LIMITER

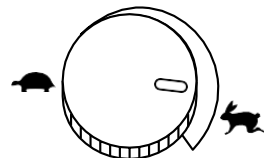

FLOW CONTROL

## PRESSURE COMPENSATING CLOSED CENTER SYSTEM (PC CLOSED)

Regulate oil flow by using a **RESTRICTOR ORIFICE**.

(Do not use flow limiter.)

### Setup Instructions:

1. Install restrictor orifice insert inside the adapter/restrictor body in the motor inlet port (marked **I**).
2. Close motor needle valve: loosen jam nut, screw needle valve clockwise until seated, and lock jam nut. (factory setting)
3. Set "Rabbit/Turtle" flow control to "Turtle".
4. Move hydraulic lever to the "Lower/Retract" position to start pump.
5. Adjust "Rabbit/Turtle" flow control and sprayer agitation valve to get desired spraying pressure.

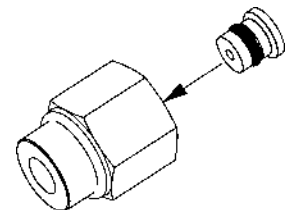

RESTRICTOR ORIFICE

## OPEN CENTER SYSTEM (OPEN)

Select motor size closest to tractor's hydraulic system capacity. Regulate oil flow with motor **NEEDLE VALVE**.

(Do not use restrictor orifice or flow limiter.)

### Setup Instructions:

1. Shut off sprayer boom and agitation valves.
2. Loosen jam nut on motor and back out needle valve 3 or 4 turns counterclockwise.
3. Set tractor throttle to sprayer operating speed.
4. Move hydraulic lever to "Lower/Retract" position to start pump.
5. Screw needle valve clockwise until sprayer shut-off pressure is below maximum shown in table on page 3 and lock jam nut.
6. Open the sprayer agitation valve to get desired spraying pressure.

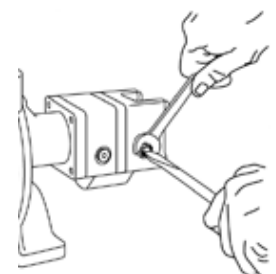

NEEDLE VALVE

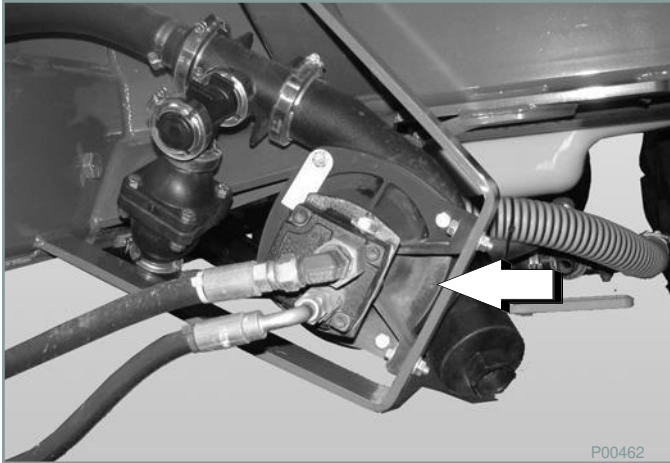

**PRE-OPERATION SETUP (CONT'D)****Controls Description****Figure 10**

**Metering Pump:** Is located on the left side in front of the main tire [Figure 10]. (See the metering valve Operator's Manual for operation.)

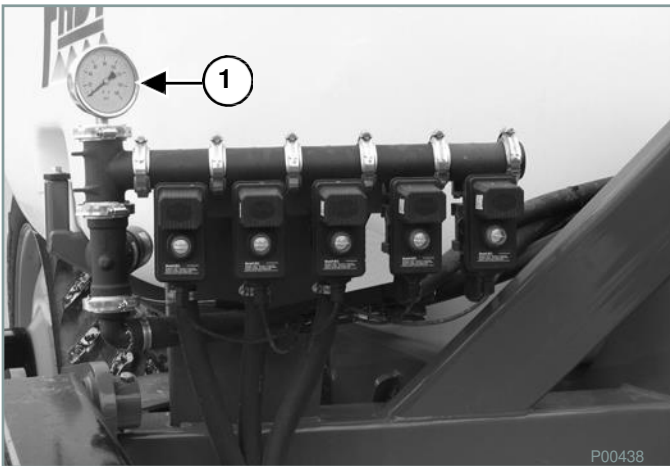
**Figure 11**

**Liquid System Pressure Gauge:** Located in front of the main tank on the right side (Item 1) [Figure 11]. The gauge monitors pressure in liquid circuit providing flow to injectors. It is normally used to monitor pressure in chemical/fertilizer circuits when setting system for a specific application rate.

**NOTE: Monitor gauge during operation. Stop and check system if pressure changes suddenly.**

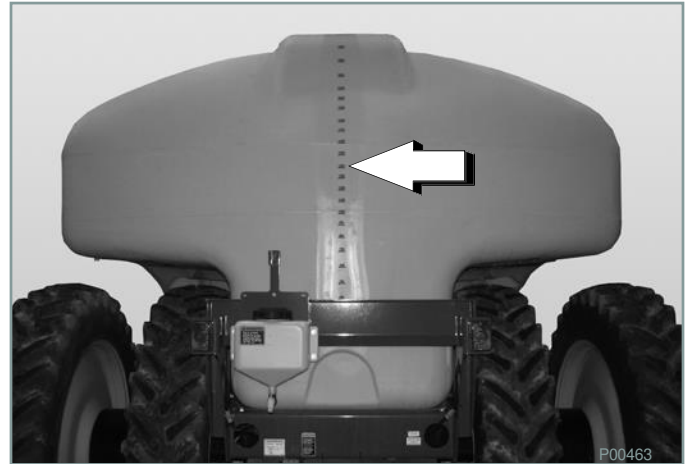
**Figure 12**

**Tank Scale:** The back end of tank has a capacity scale molded into it to assist operator when filling tank.

**Automatic Controller (Optional):** Monitors, sets and controls the operation of the applicator. (See the automatic controller's Operator's Manual for operation.)

POST-OPERATION SETUP (CONT'D)  
Leveling The Liquid Fertilizer Applicator

# IMPORTANT

The fertilizer applicator frame must be adjusted down or up until the fertilizer applicator is parallel with the ground prior to operation.

I-2015-019

Lower the toolbar. (See *Unfold And Fold Toolbar* on Page 35.)

**NOTE:** The wings and toolbar should be in the operating position before leveling the fertilizer applicator frame.

Figure 13

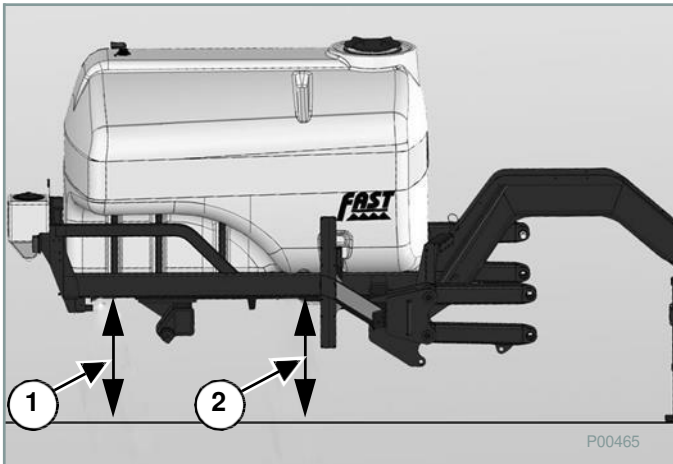

**NOTE:** Frame and tank [Figure 13] only shown for ease to show measurement locations.

Measure the distance (Items 1 & 2) [Figure 13] from the ground to the bottom of the fertilizer applicator frame in the two locations shown.

**NOTE:** The two measurements should be approximately the same when the frame is level.

To Level Liquid Fertilizer Applicator

Figure 14

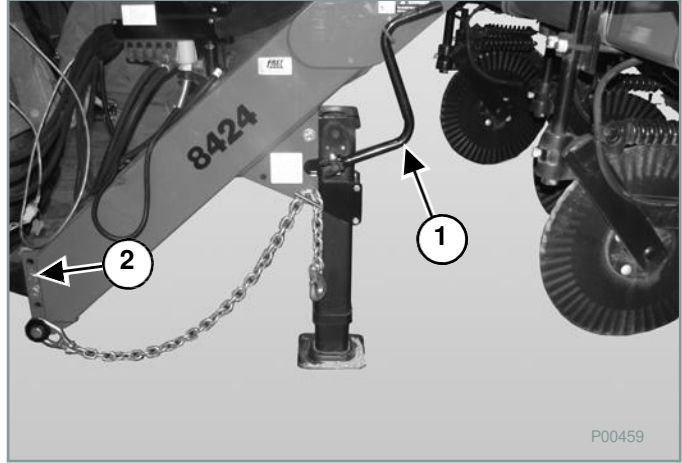

With the liquid fertilizer applicator attached to the tractor, lower the jack from the transport position. Raise the jack (Item 1) until the weight of the fertilizer applicator is on the jack. This will allow the clevis mounting bolts (Item 2) [Figure 14] to be loosened and moved for leveling (if required).

Figure 15

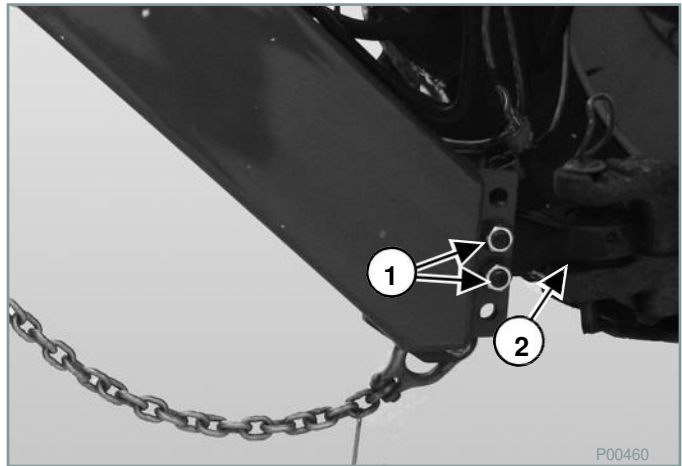

Loosen the clevis mounting bolts (Item 1) [Figure 15].

Raise or lower the jack until the fertilizer applicator frame is parallel with the ground. Raise or lower the clevis (Item 2) [Figure 15] to match tractor drawbar and align the closest clevis mounting holes with frame. Install the clevis bolts.

Tighten the clevis mounting bolts (Item 1) [Figure 15] to the correct torque and raise the jack into the storage position.



## PRE-OPERATION SETUP (CONT'D)

*Unfold Toolbar*

### Unfold And Fold Toolbar

## DANGER

### ELECTROCUTION HAZARD

To prevent serious injury or death from electrocution:

- Be aware of overhead powerlines.
- Keep away from powerlines when transporting or folding or unfolding wings.
- Electrocution can occur without direct contact.

D-2015-004

## DANGER

### CRUSH HAZARD

To avoid serious injury or death, keep everyone clear of machine when folding or extending wings.

D-2015-005

## WARNING

### AVOID INJURY OR DEATH

Before moving the tractor, look in all directions and make sure no bystanders, especially small children are in the work area. Do not allow anyone between the tractor and the equipment when backing up to the equipment for connecting.

W-2015-029

## IMPORTANT

Always have the tractor / fertilizer applicator moving forward at a minimum of 3 mph (5 kmh) when lowering the toolbar to minimize the side load on the coulters when they contact the ground.

I-2015-020

## IMPORTANT

### PREVENT WING REST DAMAGE

Never engage tractor remote lever to lower center section while main wings are in transport position.

I-2015-021

Move to the operator's position and start the engine. (See *Entering And Exiting Operator's Position on Page 30.*)

**Figure 16**

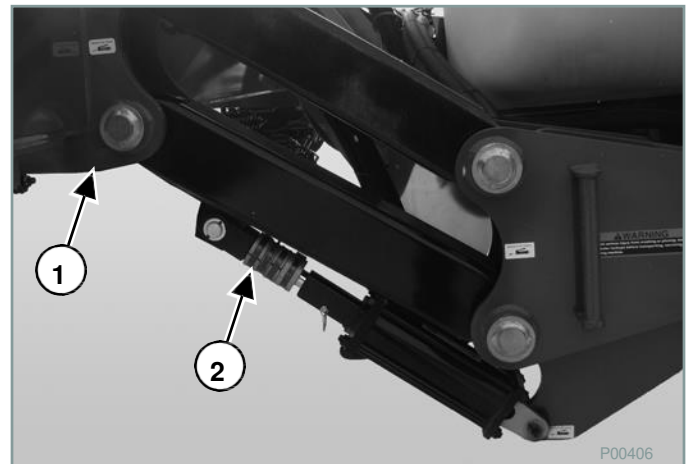

Move tractor's remote 1 lever to pressurize grey labeled hose to raise center section and wings (Item 1) up off cylinder stops (Item 2) [Figure 16]. (See the tractor's Operation & Maintenance manual.)

Move tractor's remote 2 lever to pressurize purple labeled hose to detent position. (See the tractor's Operation & Maintenance manual.)

## PRE-OPERATION SETUP (CONT'D)

### Unfold And Fold Toolbar (Cont'd)

#### Unfold Toolbar (Cont'd)

Figure 17

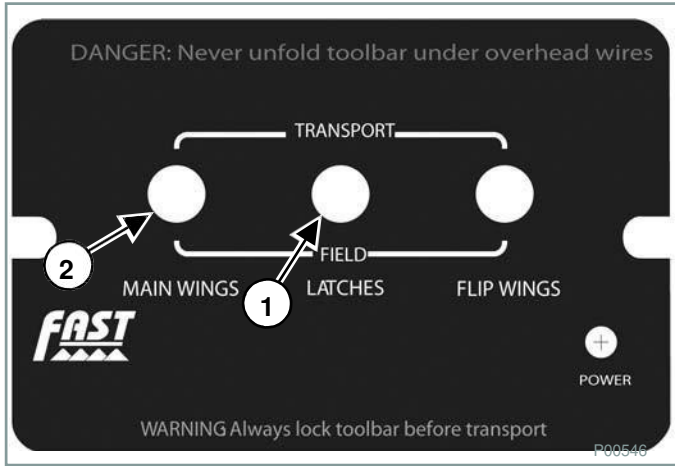

Move latches switch (Item 1) [Figure 17] to transport position for a few seconds to be certain wing latches are fully raised. Verify latches are fully raised.

Move main wing switch (Item 2) [Figure 17] to field position and hold until wings are unfolded. Wings will be laterally in line with center section when fully unfolded.

**NOTE: In soft field conditions, it may be required to back up to get wings to fully extend.**

Figure 18

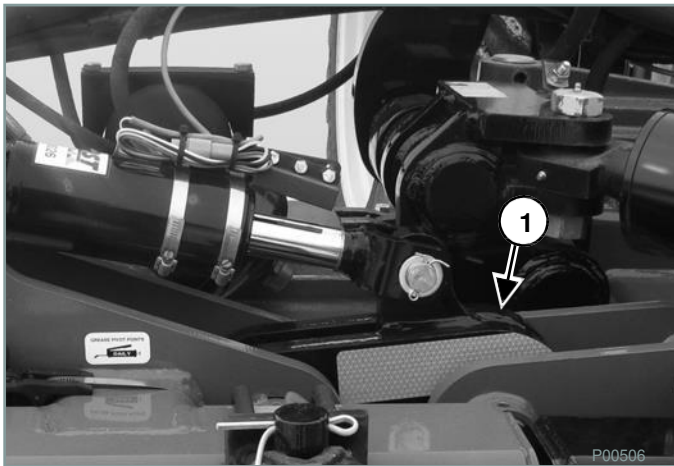

Move latches switch (Item 1) [Figure 17] to field position and hold to fully engage wing latches (Item 1) [Figure 18].

Figure 19

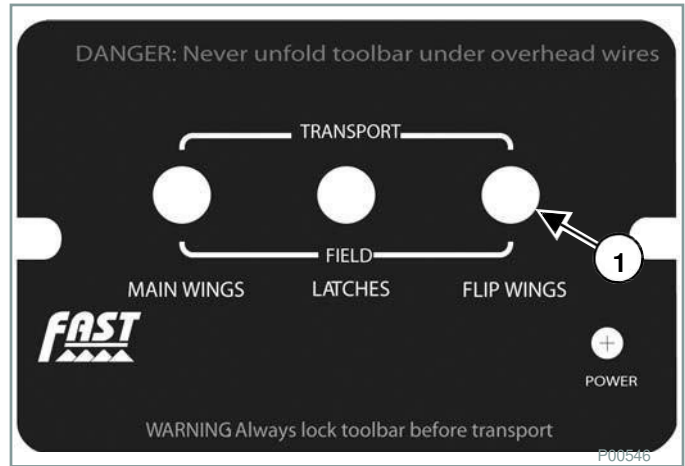

Move flip wing switch (Item 1) [Figure 19] to field position and hold to unfold flip wings.

**NOTE: The toolbar should be completely unfolded with wing tips angled up in the kicked position.**

## PRE-OPERATION SETUP (CONT'D)

### Unfold And Fold Toolbar (Cont'd)

#### Unfold Toolbar (Cont'd)

**Figure 20**

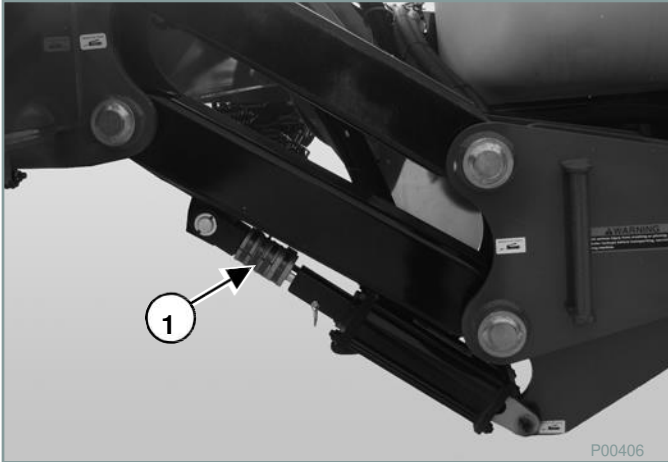

Install spacers (Item 1) [Figure 20] on toolbar lift cylinder ram to set required machine depth. Toolbar can then be fully lowered and will always return to same depth.

#### Fold Toolbar

Move tractor remote #1 lever, to pressurize grey-labeled hose to raise toolbar and kick wings up. (See the tractor's Operation & Maintenance manual.)

Move tractor remote #2 lever, to pressurize purple-labeled hose to supply oil for cab box folding functions. (See the tractor's Operation & Maintenance manual.)

**Figure 21**

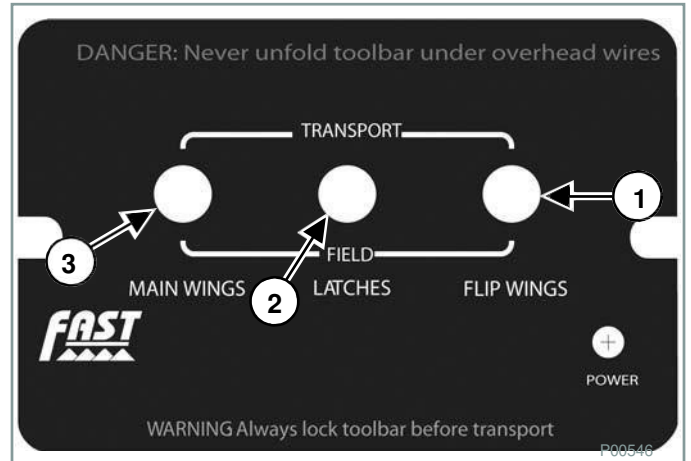

Hold flip wings toggle switch (Item 1) [Figure 21] to transport position until flip wings are fully folded.

Move and hold latches switch (Item 2) [Figure 21] to transport position to raise latches.

Move and hold main wing toggle switch (Item 3) [Figure 21] to transport position until main wing bumps into wing rest vertical back stop.

Disengage tractor remote #2 lever (purple-labeled hose) and install main lift transport segment on both main lift cylinders. Repeat at caster wheel cylinder (two places) (See the tractor's Operation & Maintenance manual.)

## PRE-OPERATION SETUP (CONT'D)

### Unfold And Fold Toolbar (Cont'd)

#### Raising And Lowering Toolbar

# IMPORTANT

**EXCESS PRESSURE COULD CAUSE  
DAMAGE TO TOOLBAR AND COULTERS.**

- Use only as much down pressure as needed to get coulters to proper depth.
- Do not exceed 1500 psi (10342 kPa).

I-2015-022

# IMPORTANT

**Always have the tractor / fertilizer applicator moving forward at a minimum of 3 mph (5 kmh) when lowering the toolbar to minimize the side load on the coulters when they contact the ground.**

I-2015-020

Figure 22

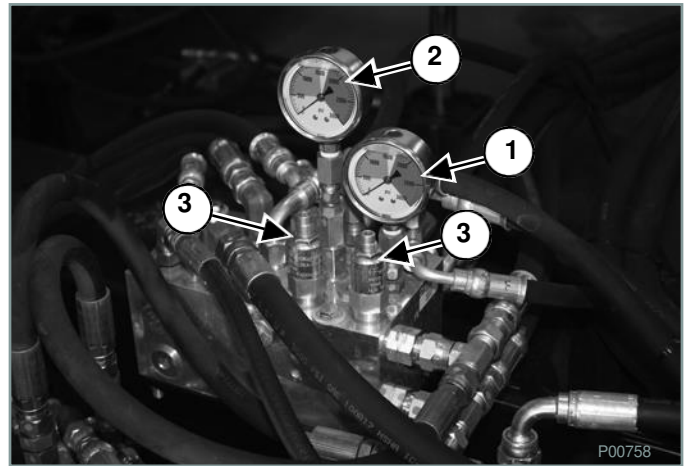

Check amount of down pressure applied to main wings by engaging remote #1 pressurize orange tagged hose continuously and lowering coulters into the ground while slowly (minimum 3 mph (5 kph)) moving ahead with unit. Hydraulic down pressure gauge (Item 1) and (Item 2) should read between 700 and 1500 psi (4826 and 10342 kPa). Down pressure may be adjusted by turning socket head screw (Item 3) [Figure 22] on down pressure valve located on toolbar near wing fold manifold.

*(See the tractor's Operation & Maintenance Manual.)*

**NOTE: Suggested starting pressures are:**

**PG1 (Item1) [Figure 22] 1200 psi (8274 kpa)**

**PG2 (Item 2) [Figure 22] 250 psi (1724 kpa)**

If down pressure needs to be adjusted, turn socket head screw clockwise to increase pressure and turn counterclockwise to decrease down pressure. To change pressure, loosen jam nut, turn adjustment stem 1/4 turn at a time. Reverse the tractor remote #1 to fully raise toolbar and kick wings up. Toolbar is now ready for field application.

## PRE-OPERATION SETUP (CONT'D)

### Tool Bar Raise/Lower Adjustments

# IMPORTANT

Always have the tractor / fertilizer applicator moving forward at a minimum of 3 mph (5 kmh) when lowering the toolbar to minimize the side load on the coulters when they contact the ground.

I-2015-020

**NOTE:** It is recommended that the coulters are set so the injectors or knives place the fertilizer 2 - 3 in. (50 - 75 mm) below the soil surface. Check fertilizer/chemical manufacturer for their recommended depth.

Enter the operator's position, start the engine and release the parking brake. (See *Entering And Exiting Operator's Position on Page 30.*)

Move the tractor and fertilizer applicator to a level area in the field.

Engage the tractor hydraulics. (See the tractor's Operation & Maintenance manual.)

Unfold and fully extend the toolbar. (See *Unfold Toolbar on Page 35.*)

# IMPORTANT

Failure to keep tractor remote #1 gray tagged hose engaged and supply a constant oil flow to down pressure system will result in coulter riding out of the ground, and could result in structural failure of the toolbar and/or hydraulic cylinder components.

I-2015-023

With the tractor/liquid fertilizer applicator moving, lower center section and main wing kick by engaging the tractor remote #1.

**NOTE:** Tractor remote #1 gray tagged hose must be constantly engaged providing oil supply to and from down pressure circuit.

Figure 23

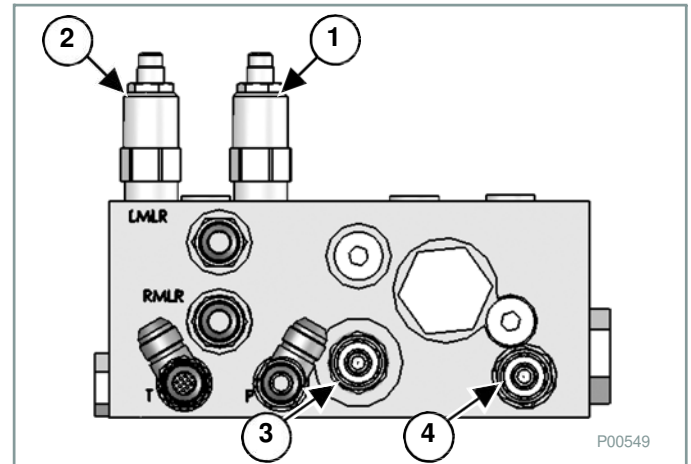

Lift assist block [Figure 23] adjustments:

- PG1 (Item 1) sets down pressure for flip wing.
- PG2 (Item 2) sets down pressure for main trail wing.
- (Item 3) Sets center section raise rate.
- (Item 4) Sets flip wing drop rate.

**NOTE:** Normal operating range for down pressure (Item 1 & 2) [Figure 23] is 700 - 1500 psi (4826 - 10342 kpa). Use the lowest pressure possible to keep coulters in the ground.

**NOTE:** Suggested start point is:  
1200 psi (8274 kpa) on #1 circuit PG1 (Item 1)  
250 psi (1724 kpa) on #2 circuit PG2 (Item 2)

**NOTE:** Correct setting has the caster wheels fully extended before center section is completely up.

Gradually turn up hydraulic flow to this circuit to confirm flow is adequate and not the problem. (Typically the circuit is at full flow.)

## PRE-OPERATION SETUP (CONT'D)

### Tool Bar Raise/Lower Adjustments (Cont'd)

Figure 24

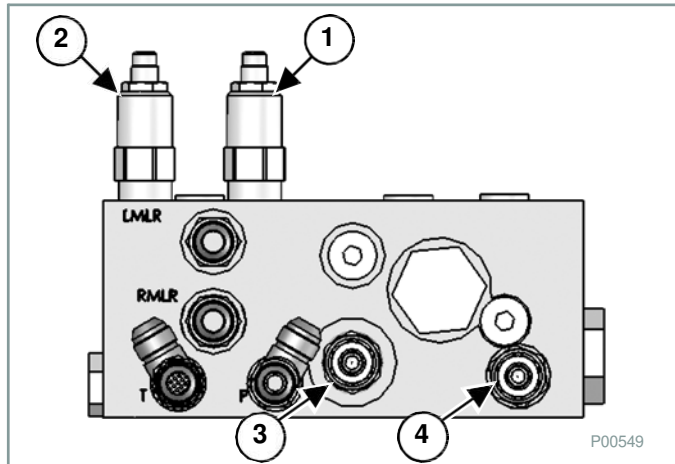

Lift assist block [Figure 24] adjustments:

- (Item 3) Sets center section raise rate.

**NOTE:** When raising the center section and the wings, the wings need to get up to the fully up position before the center section gets fully raised. Turning the screw in speeds up the center section lift.

**NOTE:** When the center section gets fully raised, the oil flow to the caster raise is cutoff.

- (Item 4) Sets flip wing drop rate.

**NOTE:** To slow the drop rate, turn the adjustment screw clockwise. To make the drop rate for faster, turn the adjustment screw counterclockwise. Adjust 1/8 turn at a time.

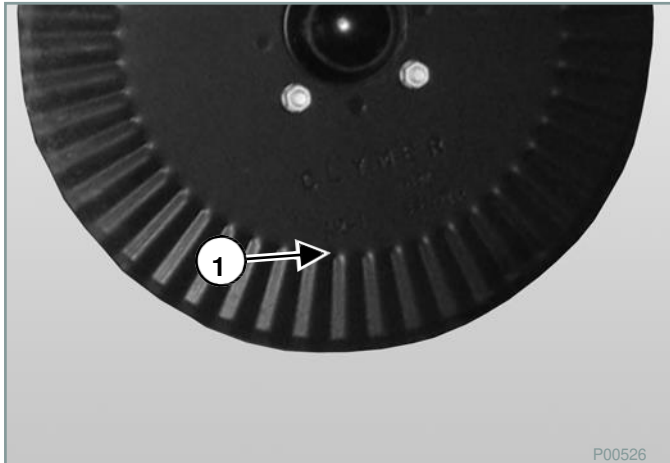
**PRE-OPERATION SETUP (CONT'D)****Adjust Coulter Depth****Figure 25**

**NOTE:** It is recommended to adjust coulters no deeper than the top of the coulter ripples (Item 1) [Figure 25] 3 in. (76 mm).

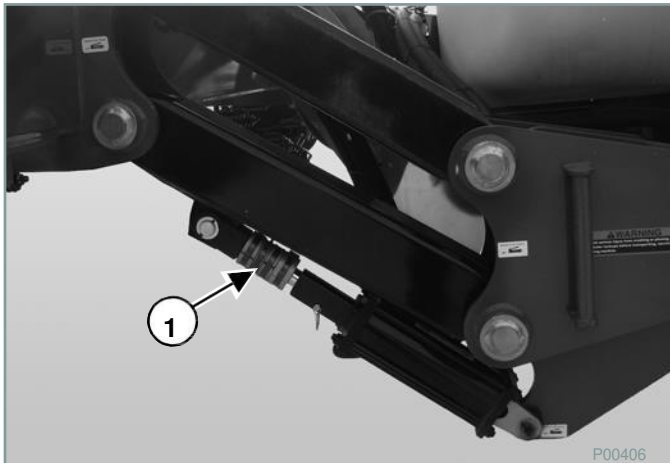
**Figure 26**

When desired depth is reached, install spacers (Item 1) [Figure 26] on toolbar lift cylinder ram.

**NOTE:** Toolbar can then be fully lowered and always return to same depth.

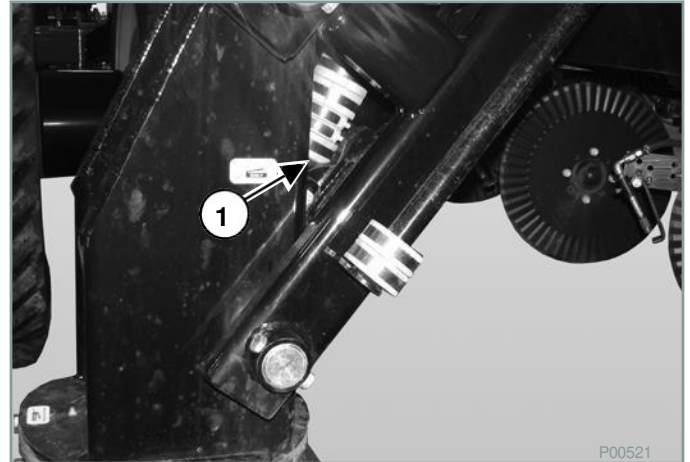
**Figure 27**

Install spacers on casters (Item 1) [Figure 27] to give required machine depth.

**NOTE:** The caster wheels are not designed to be the only coulter depth control.

## PRE-OPERATION SETUP (CONT'D)

### Tool Bar Raise/Lower Adjustments (Cont'd)

Figure 28

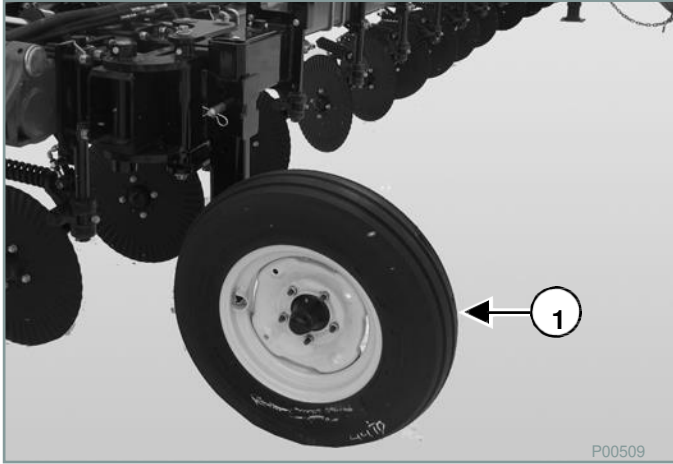

Gauge wheel (Item 1) [Figure 28] helps to maintain application depth in adverse ground conditions.

- Lower gauge wheels if soil conditions are soft.
- Raise gauge wheels if soil conditions are hard to obtain the same application depth.
- Set gauge wheels so wings are level front to back.

Figure 29

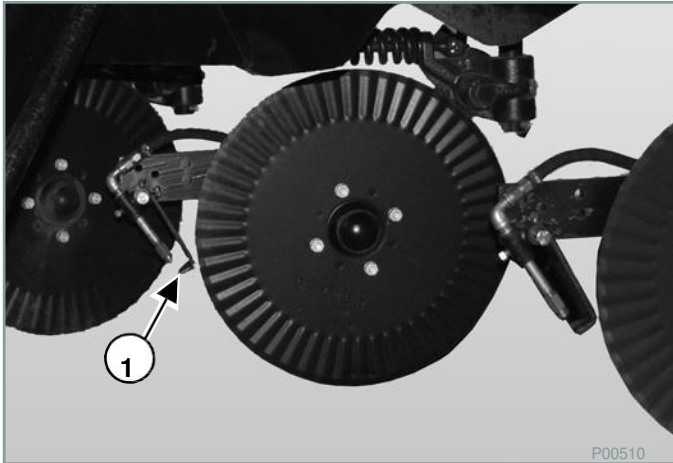

Nozzles/Knives (Item 1) [Figure 29] need to be adjusted to the correct height. (See the nozzle/knife manufacturers instructions.)

**NOTE:** As a general guideline, tip of nozzle should be slightly above ground as unit moves over the field.

## System Screen

# ! WARNING

### AVOID SERIOUS INJURY OR DEATH

- Check chemical or fertilizer MSDS for proper handling instructions.
- Toxic chemicals can enter the body by breathing, spray or contact with bare skin. Do not take a chance with your health and safety.

W-2015-032

Figure 30

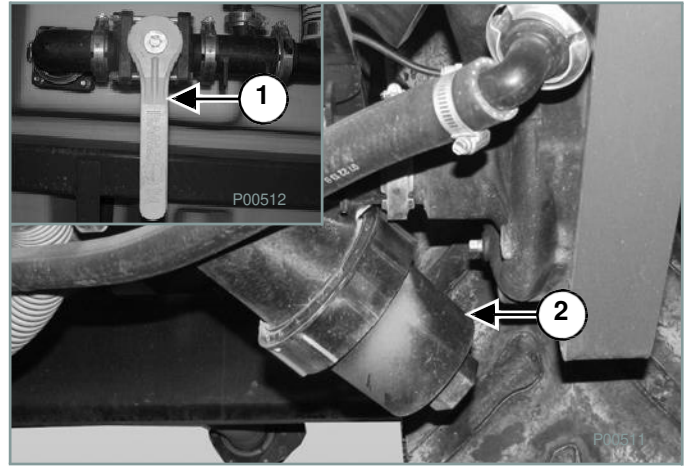

Close valve (Item 1), remove filter bowl and screen (Item 2) [Figure 30] and wash with clean water *DAILY*. Clean liquid is required to prevent nozzle plugging.

**NOTE:** Collect and dispose of any liquid in an approved container.



## FIELD OPERATION



### CRUSHING HAZARD

- Before moving the tractor / equipment, look in all directions and make sure no bystanders are in the work area.
- Do not allow anyone between the tractor and the equipment when backing up to the equipment for connecting.

W-2014-005



### CRUSHING HAZARD

Keep fingers and hands out of pinch points when connecting and disconnecting equipment.

W-2014-002



### AVOID INJURY OR DEATH

Use of an unapproved hitch or tow vehicle can result in loss of control, leading to serious injury or death. Tractor and hitch must have the rated capacity to tow this equipment.

W-2014-004



Verify that the equipment is securely fastened to the tractor before moving the tractor and equipment.

W-2014-006



### AVOID INJURY OR DEATH

Pay attention to surrounding areas to prevent being crushed between two pieces of equipment.

W-2013-020



### AVOID INJURY OR DEATH

Install and secure all guards and shields before starting or operating.

W-2015-019



### AVOID INJURY OR DEATH

Do not allow riders on the applicator or tractor during operation or transporting.

W-2015-021

 **WARNING**

**AVOID INJURY OR DEATH**

**Clear area of all bystanders, especially children, before starting or filling with chemical or fertilizer.**

W-2015-022

---

 **WARNING**

**AVOID INJURY OR DEATH**

**Do not breathe, touch or ingest chemicals or fertilizer. Always wear protective clothing and follow safe handling procedures.**

W-2015-024

---

 **WARNING**

**AVOID INJURY OR DEATH**

**Read chemical or fertilizer manufacturers warnings, instructions and procedures before starting and follow them exactly.**

W-2015-023

---

 **WARNING**

**AVOID INJURY OR DEATH**

**Stay away from wings when folding or extending wings. Keep others away.**

W-2015-025

---

 **WARNING**

**AVOID INJURY OR DEATH**

**Do not exceed a safe travel speed.**

W-2015-026

---

 **WARNING**

**AVOID INJURY OR DEATH**

**Stay away from overhead power lines when folding or extending the wings and during transport.**

W-2015-027

---

## FIELD OPERATION (CONT'D)

### IMPORTANT

Clean reflectors, SMV emblem and lights before transporting.

I-2015-014

### IMPORTANT

Attach securely to towing unit using a hardened pin with a retainer and a safety chain.

I-2015-015

### IMPORTANT

Use hazard flasher on tractor when transporting.

I-2015-016

### IMPORTANT

Verify main tank is empty before transporting on road.

I-2015-017

Attach applicator to machine. (See *Connecting The Fertilizer Applicator To The Tractor on Page 30.*) & (See *Connecting Hydraulic Hoses And Electrical Connections on Page 32.*)

Review and follow pre-operation checklist. (See *Connecting The Fertilizer Applicator To The Tractor on Page 30.*)

Unfold/extend toolbar. (See *Unfold Toolbar on Page 35.*)

Set the coulters. (See *Adjust Coulter Depth on Page 41.*)

Filling spray tank:

- Park tractor and applicator on a flat surface.
- Read and follow chemical/fertilizer manufacturers' instructions.

 **DANGER**



#### CHEMICAL HAZARD

To prevent serious injury or death:

##### WEAR PERSONAL PROTECTIVE EQUIPMENT

- Do not allow chemicals or solution to touch skin.
- Some chemicals can be absorbed through the skin.
- Wear rubber gloves and protective gear at all times.

##### DON'T BREATHE VAPOR

- Avoid chemical splash and vapor. Keep others away.
- Do not breathe vapor.
- Wear proper respirator when working with chemicals.
- Chemicals can be toxic.

##### DON'T INGEST CHEMICAL

- If in eyes or mouth, read manufacturer's instructions and follow them exactly.
- Seek immediate medical attention.
- Before working with chemicals, know the poison control phone number for your location.

D-2015-006

## FIELD OPERATION (CONT'D)

# WARNING

### AVOID SERIOUS INJURY OR DEATH

Always read the label before using chemicals. Follow the instructions from the chemical manufacturer on how to select, use and handle each chemical. Note protection information each time before opening the container.

W-2015-035

# WARNING

### AVOID SERIOUS INJURY OR DEATH

Do not spill chemicals on skin or clothing. If chemicals are spilled, remove contaminated clothing immediately and wash skin (and clothing) thoroughly with soap and water. Wash hands and face with soap and water and change clothing after spraying.

W-2015-034

# IMPORTANT

Verify main tank is empty before transporting on road.

I-2015-017

Figure 31

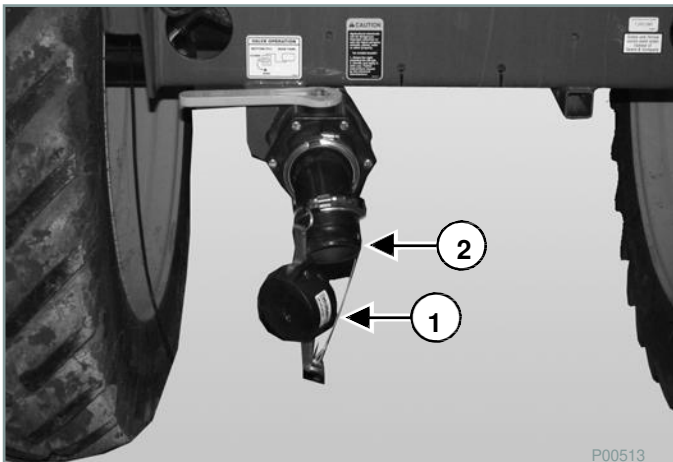

- Move tender truck to applicator.
- Remove cover (Item 1) [Figure 31]
- Connect transfer hose to bottom fill line (Item 2) [Figure 31].
- Start pump on tender truck and open valve on input line. (See tender truck Operation & Maintenance manual.)

Figure 32

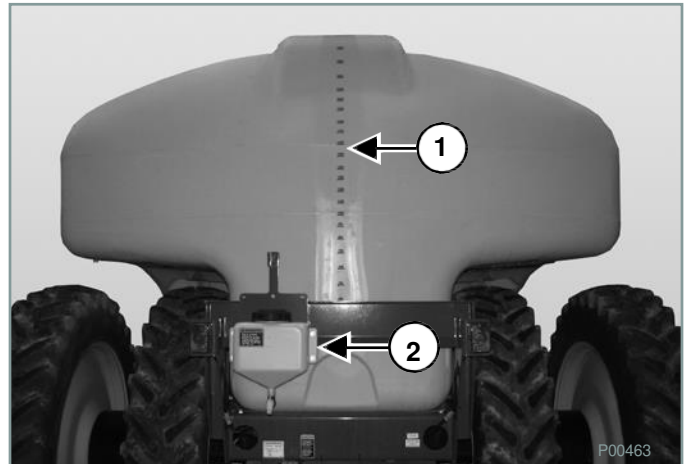

- Pump until tank is filled to desired level (Item 1) [Figure 32]. Verify level using capacity scale.

**NOTE: Do not overfill.**

- Close input valve and stop pump on tender truck. (See tender truck Operation & Maintenance manual.)
- Remove and stow fill line.
- Install and fasten input line covers (Item 1) [Figure 31].

Fresh Water Rinse Tank:

- Fill rinse tank with clean fresh water (Item 2) [Figure 32].

**NOTE: Do not allow rinse tank to run low on fresh water. Use water from rinse tank to clean, rinse or wash anything that has become contaminated.**

Set applicator controller for **EXACTLY** how much liquid is being applied.

**NOTE: Incorrect application rates can dramatically affect seed germination and yields. Set at start of season or when changing application rate.**



## FIELD OPERATION (CONT'D)

### Starting:

- Set engine RPM at rated speed. *(See the tractor's Operation & Maintenance manual.)*
- Engage tractor's hydraulic system. *(See the tractor's Operation & Maintenance manual.)*
- Place hydraulic motor control lever in detent. *(See the tractor's Operation & Maintenance manual.)*
- Start into field.
- Lower the toolbar into ground. *(See Raising And Lowering Toolbar on Page 38.)*
- Turn on boom sections. *(See the applicator controller's Operation & Maintenance manual.)*

### Stopping:

- Turn off boom sections.
- Place hydraulic motor control lever in *float* position and lift toolbar out of ground.
- Stop forward motion of machine, place hydraulic lever in its off position.
- Reduce engine RPM to low idle.

### Emergency stop:

- If an emergency arises, shut engine *off* to stop machine or stop forward motion.

**NOTE: When starting after an emergency stop, use starting information on this page.**

Set outer wing valve.

- Set valve closed if outer wing is in the unfolded/retracted position.
- Set valve open if outer wing is in the folded/extended position.

Set ground speed.

Set desired application rate.

**NOTE: Always run at established travel speed.**

**NOTE: Best results are obtained ground speed is 5 - 8 mph (8 - 13 kph). Ground speed variations in the field will automatically be compensated. Always operate at a comfortable speeds. Do not operate so fast that toolbar or tank bounce while going through field. Effective results require that liquid be applied at a consistent depth in a consistent manner. Machine bouncing will prevent this required consistency.**

## POST-OPERATION DISCONNECTION

# WARNING

### AVOID BURNS

Hydraulic fluid, tubes, fittings and quick couplers can get hot when running equipment. Be careful when connecting and disconnecting quick couplers.

W-2015-031

Release pressure and pull the male coupler out to disconnect. (See the tractor's Operation And Maintenance manual.)

Disconnect electrical connectors from the tractor.

**Figure 33**

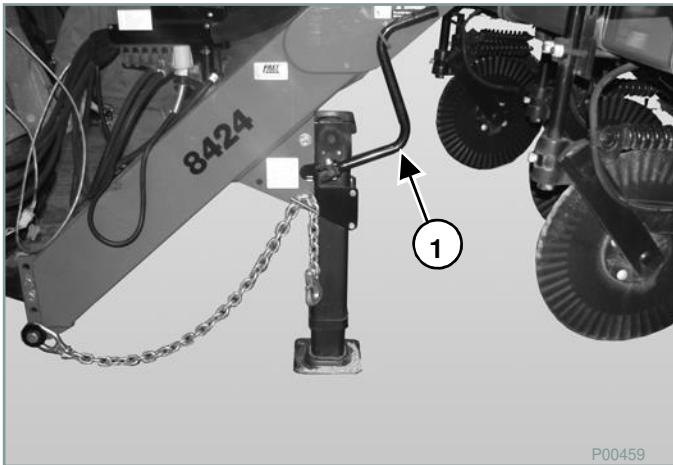

Place the jack in the vertical position.

Turn the jack handle (Item 1) [Figure 33] clockwise to raise the hitch until the weight of the applicator is on the jack.

**Figure 34**

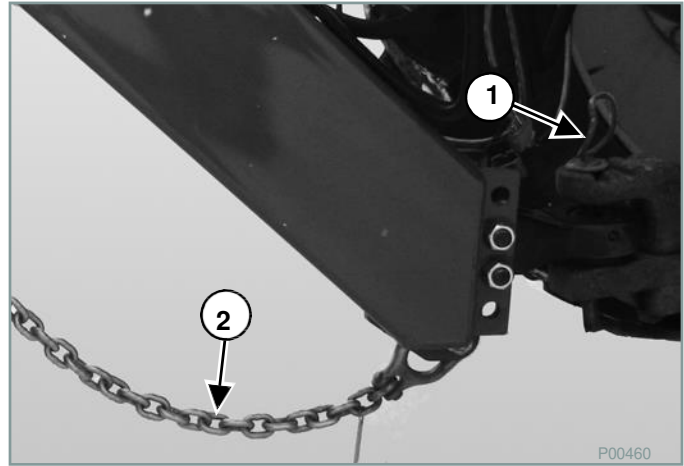

Remove the safety chain (Item 2) [Figure 34] around the drawbar.

Remove the hitch pin (Item 1) [Figure 34] and retaining pin.

Turn the jack handle (Item 1) [Figure 33] counterclockwise to lower the hitch. Place jack in the stowed position.

Move to the operator's seat, start the engine and release the parking brake. (See Entering And Exiting Operator's Position on Page 30.)

Move the tractor away from the fertilizer applicator.

## TRANSPORTATION



### DANGER

#### ELECTROCUTION HAZARD

To prevent serious injury or death from electrocution:

- Be aware of overhead powerlines.
- Keep away from powerlines when transporting or folding or unfolding wings.
- Electrocution can occur without direct contact.

D-2015-004



### WARNING

#### AVOID SERIOUS INJURY OR DEATH

Daybreak and dusk are particularly dangerous and pilot vehicles are recommended.

W-2015-033

### IMPORTANT

#### PREVENT EQUIPMENT DAMAGE.

Verify main tank is empty before transporting on road.

I-2015-025

### IMPORTANT

- Check with local authorities regarding applicator transport on public roads. Obey all applicable laws and regulations.
- Always travel at a safe speed. Use caution when making corners or meeting traffic.
- Make sure SMV (Slow Moving Vehicle) emblem and all lights and reflectors that are required by the local highway and transport authorities are in place, are clean and can be seen clearly by all overtaking and oncoming traffic.

I-2015-024

### IMPORTANT

#### PREVENT EQUIPMENT DAMAGE.

Be sure applicator is hitched securely to tractor and a retainer is used through drawbar pin. Always attach a safety chain between frame and towing vehicle.

I-2015-026

**NOTE:** Keep to right and yield right-of-way to allow faster traffic to pass. Drive on the road shoulder, if permitted by law.

Be sure all bystanders are clear of machine.

Be sure that applicator is properly connected to tractor. Always attach safety chain between machine and tractor and install a retainer through drawbar pin.

Keep safe distance from overhead power lines when folding or extending the wings.

Install transport lock spacers on lift cylinders before transporting.

**Note:** Add more lock spacers to prevent the toolbar from dropping during transport.

Depending on machine configuration, wheels may need to be moved in, inverted or duals removed to reduce machine transport width to 18 feet or less.

## TRANSPORTATION (CONT'D)

Make sure SMV (Slow Moving Vehicle) emblem and all lights and reflectors that are required by local highway and transport authorities are in place, are clean and can be seen clearly by all overtaking and oncoming traffic.

DO NOT transport faster than 20 mph (32 kmh). Follow chart below for travel speeds.

<b>MAXIMUM TRAVEL SPEED</b>	<b>WEIGHT OF FULLY EQUIPPED APPLICATOR VERSES WEIGHT OF TRACTOR</b>
20 mph (32 kmh)	1 to 1 or less
10 mph (16 kmh)	2 to 1 or less
DO NOT TOW	More than 2 to 1



## STORAGE INSTRUCTIONS



### WARNING

#### AVOID SERIOUS INJURY OR DEATH

- Store unit in an area away from human activity.
- Do not permit children to play on or around stored applicators.

W-2015-036

### Storage

At end of season, thoroughly inspect and prepare applicators for storage. Repair or replace any worn or damaged components.

- Empty remaining liquid from the tanks.
- Open liquid line connections, screen canister and pump. Drain all fluids out of system. Reinstall all plugs.
- Use 10 gal (38 l) marine RV anti-freeze, pump through screens, valve, nozzles/check valves and orifices/tips.

#### NOTE: Do not use liquid fertilizer as anti-freeze.

- Thoroughly wash applicator using a pressure washer.
- Lubricate the equipment.
- Inspect all hydraulic hoses, couplers and fittings. Replace or repair as necessary.
- Inspect all liquid lines and connections. Replace or repair as necessary.
- Touch up all paint nicks and scratches to prevent rusting.
- Install spacers on all lift cylinder rams.
- Move machine to a storage position.
- Select an area that is dry, level and free of debris.
- Unhook applicator from tractor.

## Re-Commissioning

After the FAST AG Solutions equipment has been in storage, it is necessary to follow a list of items to return the equipment to service.

- Clear area of bystanders, especially small children, and remove foreign objects from machine and working area.
- Attach tractor to applicator.
- Check:
  - ✓ Attach and secure all liquid lines
  - ✓ Coulters and nozzles
  - ✓ All hardware
  - ✓ Tire pressure
  - ✓ All hydraulic lines, fittings and connections
- Lubricate the equipment
- Replace any defective parts
- Drain anti-freeze.
- Turn pump metering system on momentarily and confirm it turns freely.
- Add a small amount of liquid to tank. Turn metering pump on momentarily and check that liquid comes out of each nozzle.
- Follow pre-operation checklist. (*See Pre-Operation Checklist on Page 28.*)





**MAINTENANCE AND REPAIR**

**MAINTENANCE AND REPAIR SAFETY PRECAUTIONS**.....55

**PREVENTATIVE MAINTENANCE**.....55

    Eight Hours Or Daily.....55

    Annually.....60

    Service Record.....61

**MAINTENANCE PROCEDURES**.....62

    Adjust Gauge Wheel Height.....62

    Nozzles.....63

**SPECIFICATIONS**.....64

    Settings.....64

    Lubricants.....64

    Torque Values.....65

**TROUBLESHOOTING**.....66

    Chart.....66



**MAINTENANCE AND REPAIR  
SAFETY PRECAUTIONS****⚠ WARNING****CRUSHING HAZARD**

Keep fingers and hands out of pinch points when connecting and disconnecting equipment.

W-2014-002

**⚠ WARNING****AVOID INJURY OR DEATH**

Use of an unapproved hitch or tow vehicle can result in loss of control, leading to serious injury or death. Tractor and hitch must have the rated capacity to tow this equipment.

W-2014-004

**⚠ WARNING****AVOID SERIOUS INJURY OR DEATH**

Lower machine to the ground, place all controls in neutral, stop engine, set park brake, remove ignition key, and wait for all moving parts to stop before servicing, adjusting, repairing or unplugging.

W-2015-037

**PREVENTATIVE MAINTENANCE****IMPORTANT****PREVENT EQUIPMENT DAMAGE.**

When lubricating the equipment:

- Use only a hand-held grease gun for all greasing.
- Wipe grease fitting with a clean cloth before greasing, to avoid injecting dirt and grit.
- Replace and repair broken fittings immediately.
- If a fitting will not take grease, remove and clean thoroughly. Clean and lubricant passageway. Replace fitting if necessary.

I-2015-027

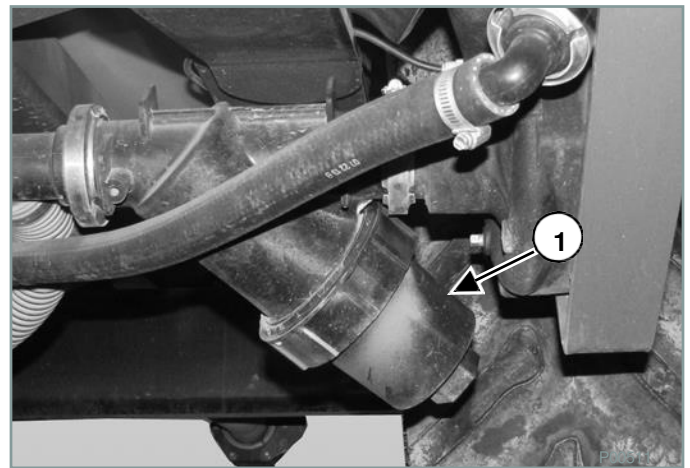
**Eight Hours Or Daily****Figure 35**

Remove filter bowl and wash fertilizer strainer screen (Item 1) [Figure 35] using clean water.

**NOTE:** Collect and dispose of any liquid in an approved container.

**PREVENTATIVE MAINTENANCE (CONT'D)**

**Eight Hours Or Daily (Cont'd)**

**Figure 36**

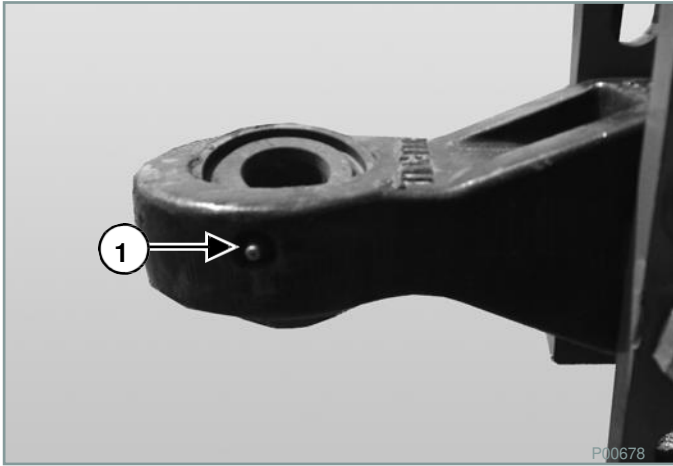

Lubricate bull pull hitch (Item 1) [Figure 36].

**Figure 37**

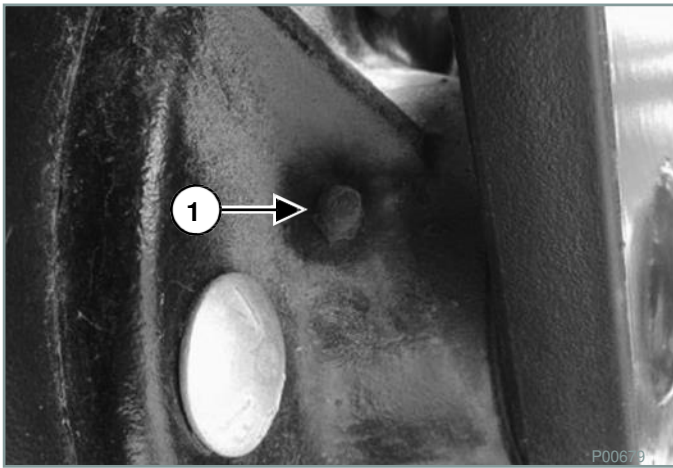

Lubricate coultter hubs (Item 1) [Figure 37].

**Figure 38**

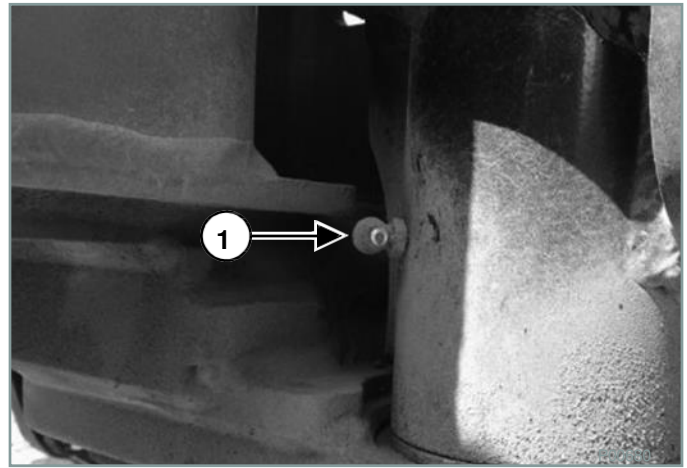

Lubricate wing pivot (Item 1) [Figure 38].

**Figure 39**

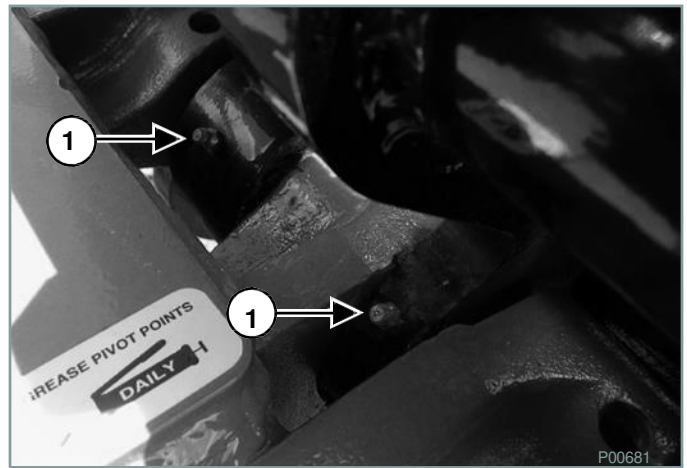

Lubricate flex hinge on wing pivot (Item 1) [Figure 39].

## PREVENTATIVE MAINTENANCE (CONT'D)

### Eight Hours Or Daily (Cont'd)

Figure 40

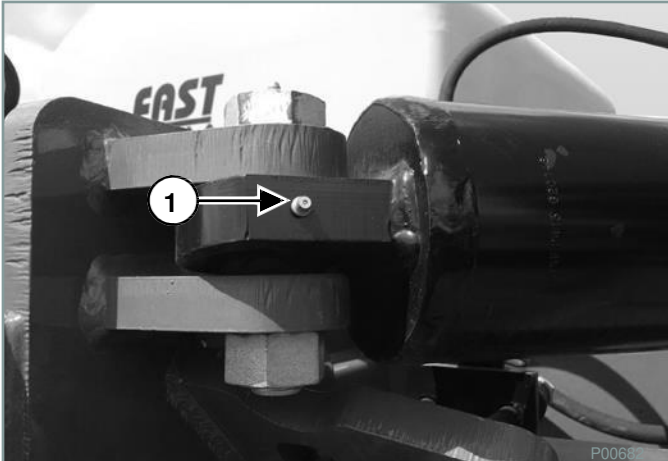
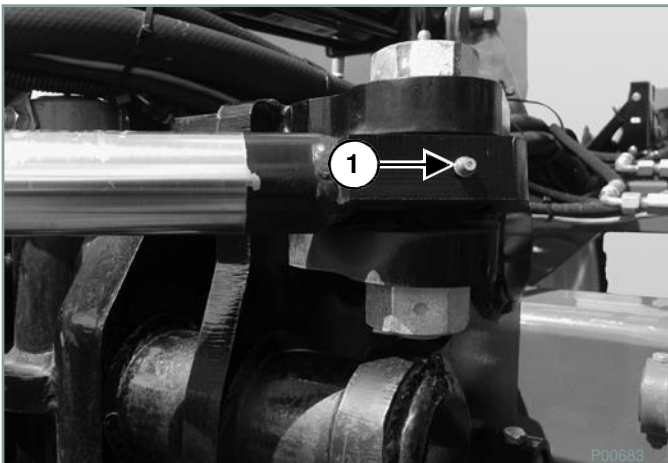
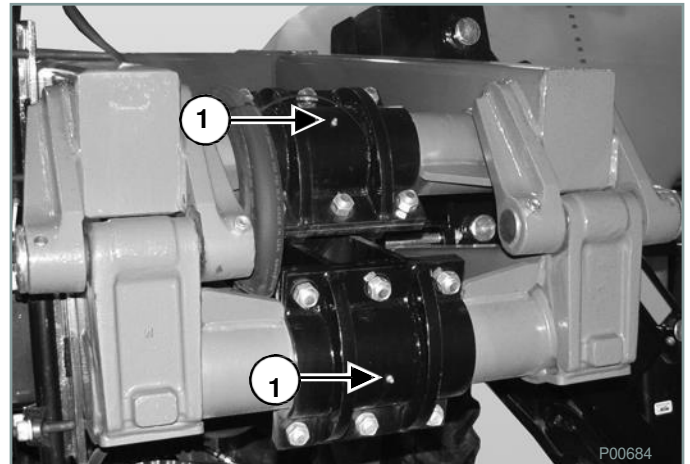

Figure 41



Lubricate swing cylinder (Item 1) [Figure 40] and [Figure 41].

Figure 42



Lubricate flip wing link (Item 1) [Figure 42].

Figure 43

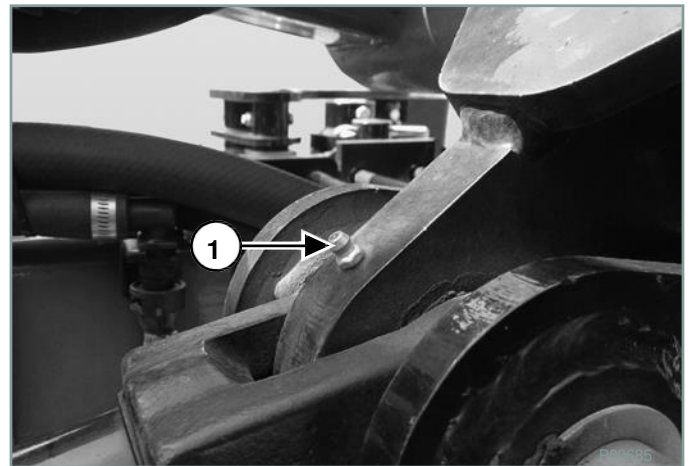

Lubricate flip wing cylinder pin (Item 1) [Figure 43].

**PREVENTATIVE MAINTENANCE (CONT'D)**

**Eight Hours Or Daily (Cont'd)**

**Figure 44**

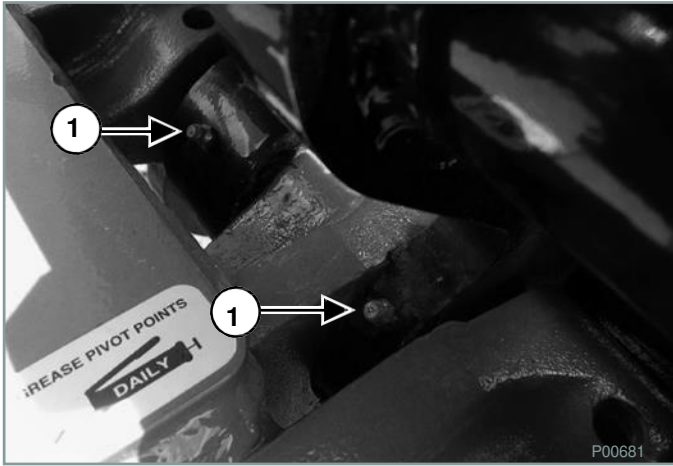

Lubricate flex hinge on wing pivot (Item 1) [Figure 44].

**Figure 45**

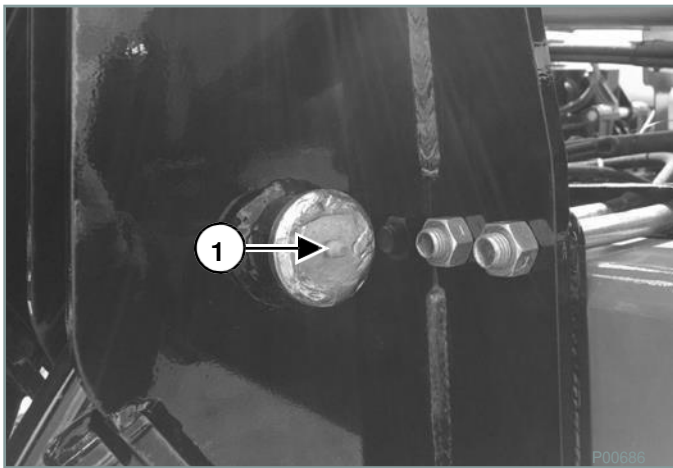

Lubricate caster parallel link pin (Item 1) [Figure 45] (eight places).

**Figure 46**

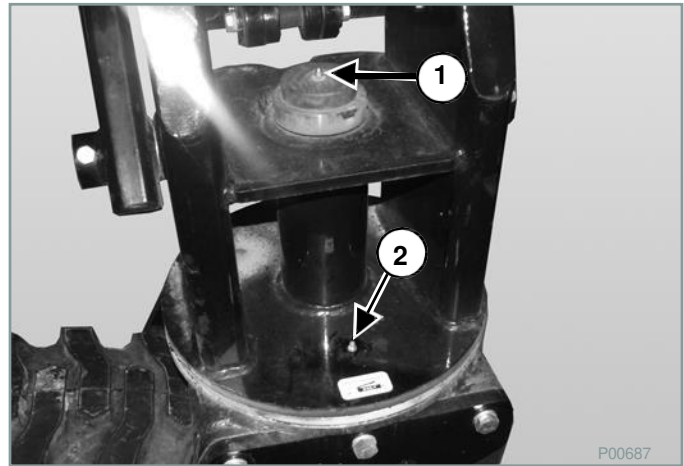

Lubricate caster spindle top (Item 1) and spindle pivot plate (Item 2) [Figure 46].

**Figure 47**

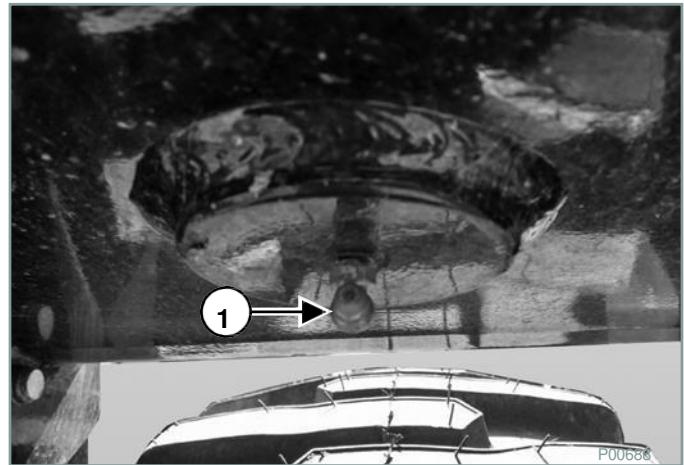

Lubricate caster spindle bottom bearing (Item 1) [Figure 47].

**Figure 48**

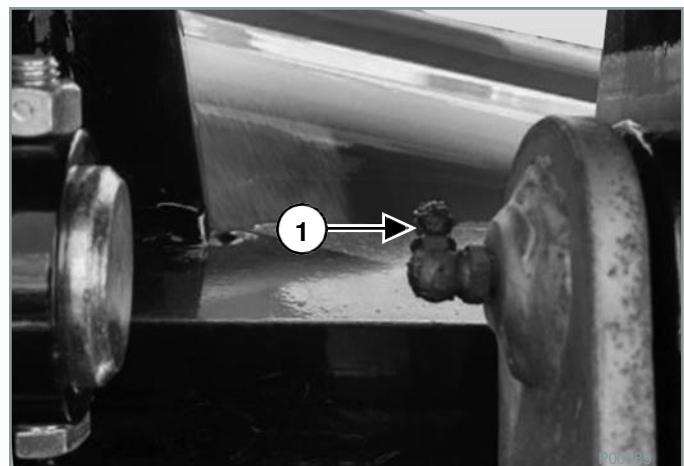

Lubricate caster spindle cylinder top pin (Item 1) [Figure 48].



## PREVENTATIVE MAINTENANCE (CONT'D)

### Eight Hours Or Daily (Cont'd)

Figure 49



Lubricate toolbar parallel linkage [Figure 49] (5 locations per side).

Figure 50

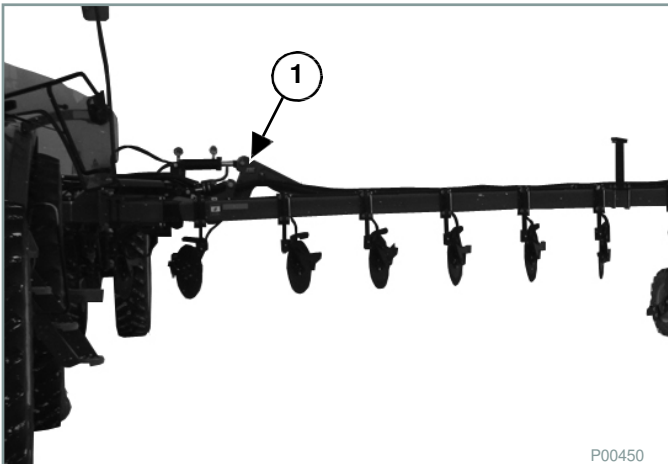

Lubricate flip wing toolbar hinges (Item 1) [Figure 50] (two locations per side).

Figure 51

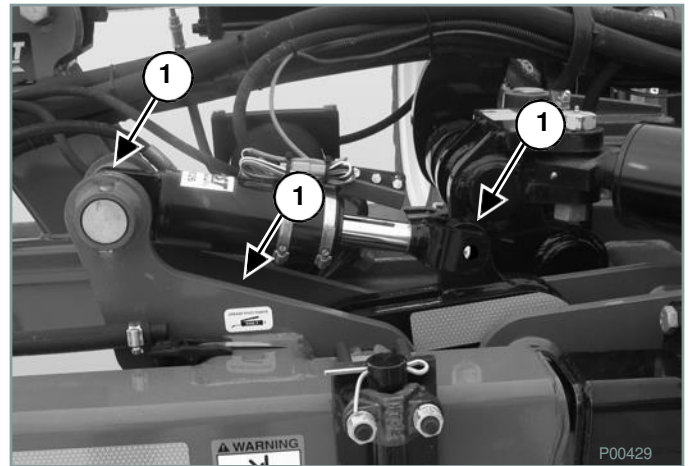

Lubricate inner wing hinges, latch cylinder pins and fold pins (Item 1) [Figure 51] (three locations per hinge).

## PREVENTATIVE MAINTENANCE (CONT'D)

### Annually

Figure 52

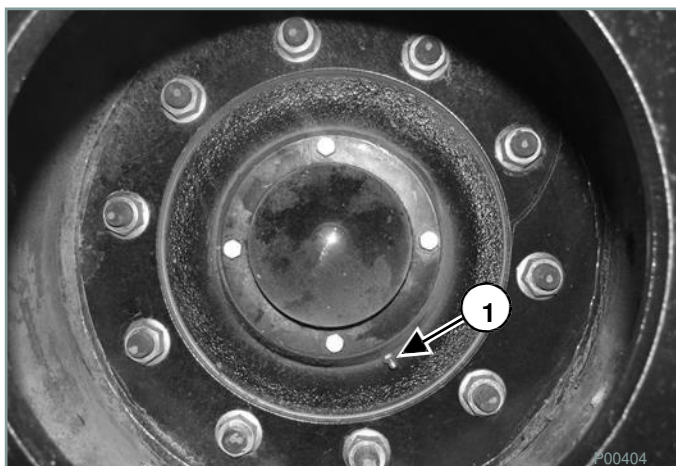

Grease wheel bearings (Item 1) [Figure 52].

Figure 53

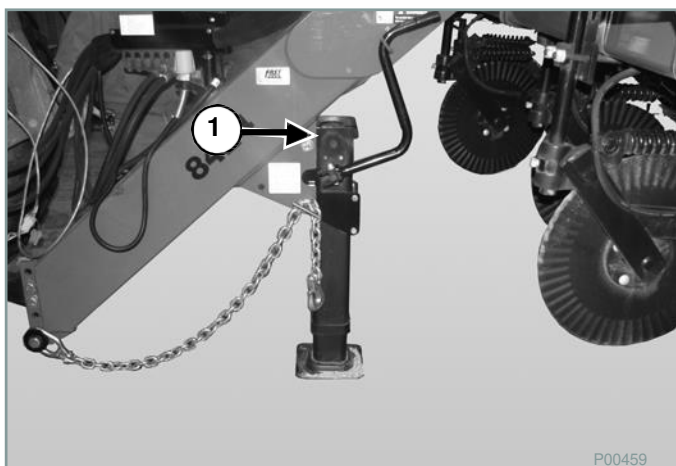

Jack preventative maintenance [Figure 53]:

1. Remove jack from mount.
2. Remove top cover (Item 1) and check grease level.
3. Install cover (Item 1) and install jack on machine.



**PREVENTATIVE MAINTENANCE (CONT'D)**

**Service Record**

ITEM	HOURS												
	SERVICED BY												
8 Hours or Daily													
Strainer Screen (C)													
Toolbar Linkage (L)													
Flip Wing Hinges (L)													
Inner Wing Hinges (L)													
Annually													
Wheel Bearings (L)													
Jack(L)													

(C)-Cleaning

(L)-Lubricating

Place a check mark (.) next to the item completed.

Copy this page to continue service record history.

ITEM	HOURS												
	SERVICED BY												
8 Hours or Daily													
Strainer Screen (C)													
Toolbar Linkage (L)													
Flip Wing Hinges (L)													
Inner Wing Hinges (L)													
Annually													
Wheel Bearings (L)													
Jack(L)													

(C) - Cleaning

(L) - Lubricating

Place a check mark (✓) next to the item completed.

Copy this page to continue service record history.

 **WARNING**

Check for correct function after adjustments, repairs or service. Failure to make needed repairs or adjustments can cause injury or death.

W-2013-003

**Adjust Gauge Wheel Height**

**Figure 54**

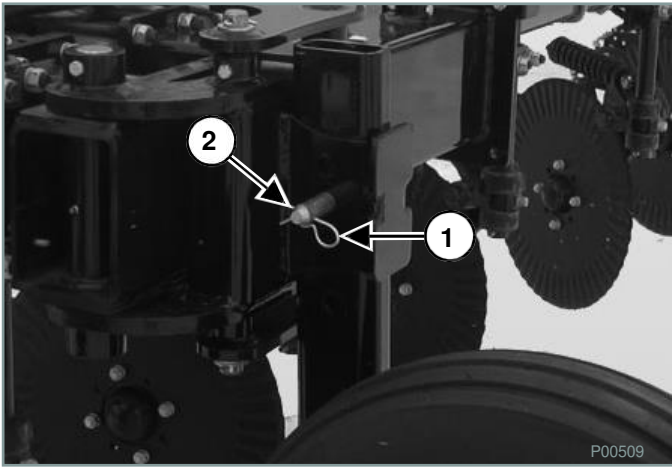

Remove lock pin (Item 1) and pin (Item 2) [Figure 54] and adjust gauge wheel height as desired.

Install pin (Item 2) and lock pin (Item 1) [Figure 54].

**MAINTENANCE PROCEDURES (CONT'D)****Nozzles** **WARNING****AVOID SERIOUS INJURY OR DEATH**

- Check chemical or fertilizer MSDS for proper handling instructions.
- Toxic chemicals can enter the body by breathing, spray or contact with bare skin. Do not take a chance with your health and safety.

W-2015-032

 **WARNING****AVOID SERIOUS INJURY OR DEATH**

Lower machine to the ground, place all controls in neutral, stop engine, set park brake, remove ignition key, and wait for all moving parts to stop before servicing, adjusting, repairing or unplugging.

W-2015-037

Extend wings and raise toolbar to its fully upright position. (See [Unfold And Fold Toolbar on Page 35.](#))

Place safety stands under center toolbar or install transport lock spacers over lift cylinder rams.

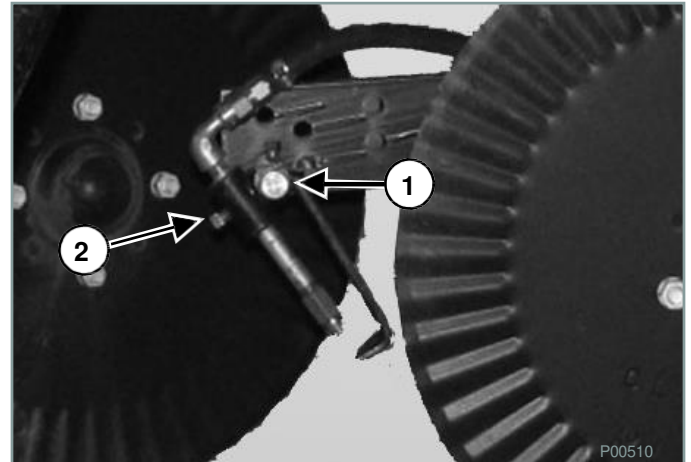
**Figure 55***Adjust Nozzle Angle*

Loosen setscrew (Item 1) [\[Figure 55\]](#) to set nozzle at required angle and centered behind couler.

**NOTE:** The best results are obtained when nozzle directs liquid approximately 1 in. (25 mm) behind couler.

*Nozzle Spray Pattern*

Loosen setscrew (Item 2) [\[Figure 55\]](#) to adjust nozzle spray parallel with furrow.

**NOTE:** Sight along nozzle and couler. Nozzle should direct liquid directly behind couler.

## SPECIFICATIONS

### Settings

Not Applicable

### Lubricants

*All Components Except Coulter:* Use an SAE multi-purpose high temperature grease with extreme pressure (EP) performance. Also acceptable is an SAE multi-purpose lithium base grease.

*Coulter:* Use an SAE premium lithium complex grease meeting NLG 1 certification GC-LB.

## SPECIFICATIONS (CONT'D)

### Torque Values

The following table shows standard torque specifications for bolts.

	<b>Thread Size</b>	<b>SAE Grade 5</b>	<b>SAE Grade 8</b>
<b>in-lb (N-m)</b>	0.250 1/4	80 - 90 (9.0 - 10.2)	110 - 120 (12.4 - 13.6)
	0.3125 5/16	180 - 200 (20.3 - 22.6)	215 - 240 (24.2 - 27.1)
<b>ft-lb (N-m)</b>	0.375 3/8	25 - 28 (34 - 38)	35 - 40 (47 - 54)
	0.4375 7/16	40 - 45 (54 - 61)	60 - 65 (81 - 88)
	0.500 1/2	65 - 70 (88 - 95)	90 - 100 (122 - 136)
	0.5625 9/16	90 - 100 (122 - 136)	125 - 140 (170 - 190)
	0.625 5/8	125 - 140 (170 - 190)	175 - 190 (240 - 260)
	0.750 3/4	220 - 245 (300 - 330)	300 - 330 (410 - 450)
	0.875 7/8	330 - 360 (450 - 490)	475 - 525 (645 - 710)
	1.000 1	475 - 525 (645 - 710)	725 - 800 (985 - 1085)
	1.125 1 1/8	650 - 720 (880 - 975)	1050 - 1175 (1425 - 1600)
	1.250 1 1/4	900 - 1000 (1200 - 1360)	1475 - 1625 (2000 - 2200)
	1.375 1 3/8	1200 - 1350 (1630 - 1830)	2000 - 2200 (2720 - 2980)
	1.500 1 1/2	1500 - 1650 (2040 - 2240)	2600 - 2850 (3530 - 3870)
	1.625 1 5/8	2000 - 2800 (2720 - 2980)	3450 - 3800 (4680 - 5150)
	1.750 1 3/4	2500 - 2750 (3390 - 3730)	4300 - 4800 (5830 - 6500)
	1.875 1 7/8	3150 - 3500 (4270 - 4750)	5500 - 6100 (7450 - 8300)
	2.000 1	3800 - 4200 (5150 - 5700)	6500 - 7200 (8800 - 9800)

## TROUBLESHOOTING

### Chart

 <b>WARNING</b>	<p>Instructions are necessary before operating or servicing equipment. Read and understand the Operation, Maintenance &amp; Parts Manual, signs (decals) on equipment. Follow warnings and instructions in the manuals when making repairs, adjustments or servicing. Check for correct function after adjustments, repairs or service. Untrained operators and failure to follow instructions can cause injury or death.</p> <p style="text-align: right;">W-2013-002</p>
--	--

Use the following troubleshooting chart to locate and correct problems which most often occur with the equipment.

PROBLEM	CAUSE	CORRECTION
Wings will not extend.	Lock valve is closed.	Open lock valve.
Applicator will not turn on.	No power.	Connect power line to 12 volt power source in tractor cab.
	Line valve is closed.	Open line valve.
	Filter screen is plugged.	Remove filter and clean screen.
Coulter does not penetrate the ground.	Down pressure too low.	Increase down-load pressure to the inner or outer wing as needed.
	Gauge wheel is set too low.	Raise gauge wheel(s) as needed.
Coulter penetrates too far into the ground.	Down pressure too high.	Decrease down-load pressure to the inner or outer wing as needed.
	Gauge wheel is set too high.	Lower gauge wheel(s) as needed.
Wings shutter / chatter when folded/unfolded.	Hydraulic flow too high.	Lower hydraulic flow to fold/unfold circuit to 6 - 15 gpm (22.71 - 56.78 lpm).
Toolbar shutters / chatters when raised.	Hydraulic flow too high.	Lower hydraulic flow to raise/lower circuit to 6 - 15 gpm (22.71 - 56.78 lpm).

**NOTE:** For Electric Schematics see *Illustrated Parts Section Pages 130 - 154.*

**NOTE:** For Hydraulic Schematics see *Illustrated Parts Section Pages 156 & 160.*



## ILLUSTRATED PARTS LISTS

Introduction	69
Part Procurement	69
Explanation Of Notations	69
8400 Liquid Fertilizer Applicator	70
Cart/Main Frame Assembly (Hitch And Jack)	74
Cart/Main Frame Assembly (Parallel Links)	76
Cart/Main Frame Assembly (Wing Transport Stops)	78
Axle Assemblies	80
Axle Assembly Options	82
Tire And Rim	84
Center Wing Assembly	86
Inner Wing Assembly (Left And Right)	88
Outer Wing Assembly (Left And Right)	92
Lift Assist And Swivel Wheel Assembly	94
Gauge Wheel Assembly	98
FAST Coulter Assembly	100
Coulter Knife Assembly	102
Coulter Injection Assembly	104
1800 - 2400 Tank Assemblies	106
Three Inch Quick Fill	108
Tank To Pump Plumbing	110
Tank To Pump Plumbing (Cont'd)	111
Large Cart To Ball Valve Plumbing	112
Toolbar Plumbing	114
Agitation And Control	116
Ace 205F - 304 Pump	118
Hypro Pump	120
Directo Valve® Electric 2-Way Ball Valve Manifold	122
1-1/2 In. Poly Control Valve Assembly (063-0171-894)	124
Flowmeter, Raven, RFM100 P Assembly (063-0171-066)	125
Flowmeter, Raven, RFM60 P Assembly (063-0171-793)	126
Raven SCS450 Console	128
Electrical Schematic Control Console Harness (115-0171-085)	130
Electrical Schematic Control Console Harness (115-0159-856)	131
Electrical Schematic Control Console Harness (115-0171-086)	132
Raven, Cable 12 Ft. Product, 10 Boom Assembly (115-0171- 313)	134
Product Controller Liquid System, 16 Pin Product Cable	136
Product Controller Liquid System, 37 Pin Product Cable	138

Cable, 17 Ft., ISO, Hitch To Raven ECU Assembly (115-0172-034)	140
Raven, Cable 4400/4600 Interface, 37 Pin Product Controller Assembly (115-0171-945)	142
Raven, Cable, Adapter, ISO To Active Terminator Assembly (115-0171-963)	144
	Fold Control Cab Box (304-041)
	146
Wiring Harness Connection (314-217)	148
Harness Connector (319-759)	149
Fold Control Block Harness (304-042)	150
Valve Block And Harness (303-131)	152
Valve Block (302-469)	153
Control Box To Control Valve Operation And Pin-Out Location	154
Fold Hydraulic System	156
Lift And Down Pressure System	160
Lift And Down Pressure Control Valve	164
Fold Valve With Fittings	166
Hydraulic Hose Description	167
Pump Hydraulic System	170
Toolbox Carrier	171
Injector And Knife Kits Contents	172
Lighting	173

## ILLUSTRATED PARTS LIST

### Introduction

These parts lists are broken down into sub-assemblies. For locations of the part's lists see page 70.

### Part Procurement

To order parts have the serial number of the equipment available. (*See Equipment Serial Number on Page 4.*)

Contact:

FAST AG Solutions  
4130 Commerce Blvd.  
Windom, MN 56101

507-427-3861

### Explanation Of Notations

The parts lists are broken down into four columns:

- ITEM NO. – These numbers are found on the illustration associated with the parts list.
- PART NO. – These are the part numbers associated to the ITEM NO.
- DESCRIPTION – This is the description of the part.
- QTY. – This is the quantity of parts needed in an assembly.
  - NS - Not Shown
  - AR - As Required
  - NA - Not Applicable





ILLUSTRATED PARTS LIST (CONT'D)  
8400 Liquid Fertilizer Applicator

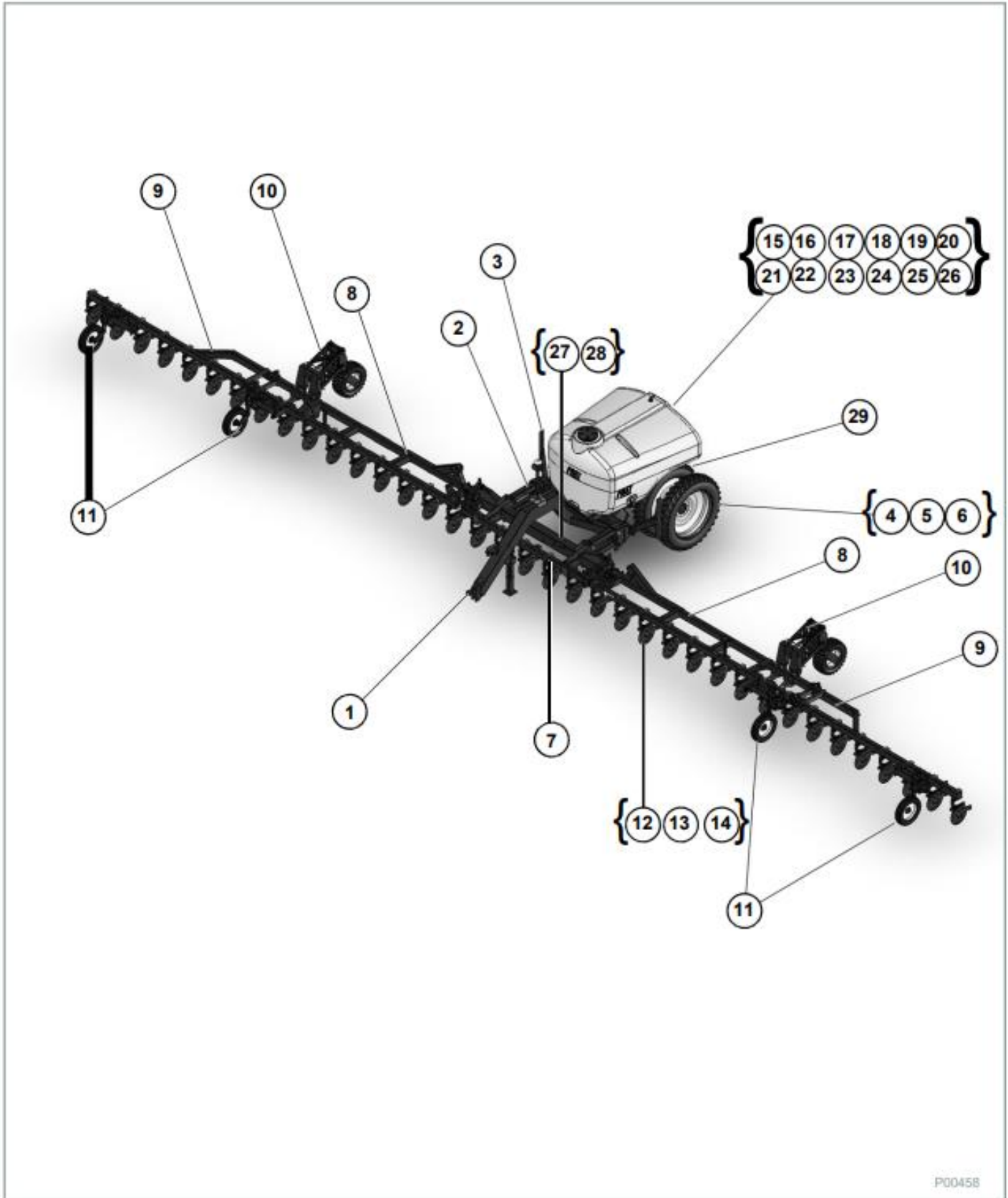

P00458

## ILLUSTRATED PARTS LIST (CONT'D)

### 8400 Liquid Fertilizer Applicator (Cont'd)

ITEM NO.	DESCRIPTION	PAGE #
1	CART/MAIN FRAME ASSEMBLY (HITCH AND JACK)	74
2	CART/MAIN FRAME ASSEMBLY (PARALLEL LINKS)	76
3	CART/MAIN FRAME ASSEMBLY (WING TRANSPORT STOPS)	78
4	AXLE ASSEMBLIES	80
5	AXLE ASSEMBLY OPTIONS	82
6	TIRE AND RIM	84
7	CENTER WING ASSEMBLY	86
8	INNER WING ASSEMBLY (LEFT AND RIGHT)	88
9	OUTER WING ASSEMBLY (LEFT AND RIGHT)	92
10	LIFT ASSIST AND SWIVEL WHEEL ASSEMBLY	94
11	GAUGE WHEEL ASSEMBLY	98
12	FAST COULTER ASSEMBLY	100
13	COULTER KNIFE ASSEMBLY	102
14	COULTER INJECTION ASSEMBLY	104
19	1800 - 2400 TANK ASSEMBLIES	106
21	THREE INCH QUICK FILL	108
20	TANK TO PUMP PLUMBING	110
26	LARGE CART TO BALL VALVE PLUMBING	112
24	TOOLBAR PLUMBING	114
25	AGITATION AND CONTROL	116
23	ACE 205F - 304 PUMP	118
22	HYPRO PUMP	120
18	DIRECTOVALVE® ELECTRIC 2-WAY BALL VALVE MANIFOLD	122
15	FLOWMETER, RAVEN, RFM60 P ASSEMBLY (063-0171-793)	126
17	1-1/2 IN. POLY CONTROL VALVE ASSEMBLY (063-0171-894)	124
16	FLOWMETER, RAVEN, RFM100 P ASSEMBLY (063-0171-066)	125
	FLOWMETER, RAVEN, RFM60 P ASSEMBLY (063-0171-793)	126
NS	RAVEN SCS450 CONSOLE	128
NS	ELECTRICAL SCHEMATIC CONTROL CONSOLE HARNESS (115-0171-085)	130
NS	ELECTRICAL SCHEMATIC CONTROL CONSOLE HARNESS (115-0159-856)	131
NS	ELECTRICAL SCHEMATIC CONTROL CONSOLE HARNESS (115-0171-086)	132
NS	RAVEN, CABLE 12 FT. PRODUCT, 10 BOOM ASSEMBLY (115-0171-313)	134
NS	PRODUCT CONTROLLER LIQUID SYSTEM, 16 PIN PRODUCT CABLE	136
NS	PRODUCT CONTROLLER LIQUID SYSTEM, 37 PIN PRODUCT CABLE	138
NS	CABLE, 17 FT., ISO, HITCH TO RAVEN ECU ASSEMBLY (115-0172-034)	142
NS	RAVEN, CABLE 4400/4600 INTERFACE, 37 PIN PRODUCT CONTROLLER ASSEMBLY (115-0171-945)	142

**ILLUSTRATED PARTS LIST (CONT'D)****8400 Liquid Fertilizer Applicator (Cont'd)**

<b>ITEM NO.</b>	<b>DESCRIPTION</b>	<b>PAGE #</b>
NS	RAVEN, CABLE, ADAPTER, ISO TO ACTIVE TERMINATOR ASSEMBLY (115-0171-963)	144
NS	FOLD CONTROL CAB BOX (304-041)	146
NS	WIRING HARNESS CONNECTION (314-217)	148
NS	HARNESS CONNECTOR (319-759)	149
NS	FOLD CONTROL BLOCK HARNESS (304-042)	150
27	VALVE BLOCK AND HARNESS (303-131)	152
28	VALVE BLOCK (302-469)	153
NS	CONTROL BOX TO CONTROL VALVE OPERATION AND PIN-OUT LOCATION	154
NS	FOLD HYDRAULIC SYSTEM	156
NS	LIFT AND DOWN PRESSURE SYSTEM	160
NS	LIFT AND DOWN PRESSURE CONTROL VALVE	164
NS	FOLD VALVE WITH FITTINGS	166
NS	HYDRAULIC HOSE DESCRIPTION	167
NS	PUMP HYDRAULIC SYSTEM	170
29	TOOLBOX CARRIER	171
NS	INJECTOR AND KNIFE KITS CONTENTS	172
NS	LIGHTING	173





ILLUSTRATED PARTS LIST (CONT'D)

Cart/Main Frame Assembly (Hitch And Jack)

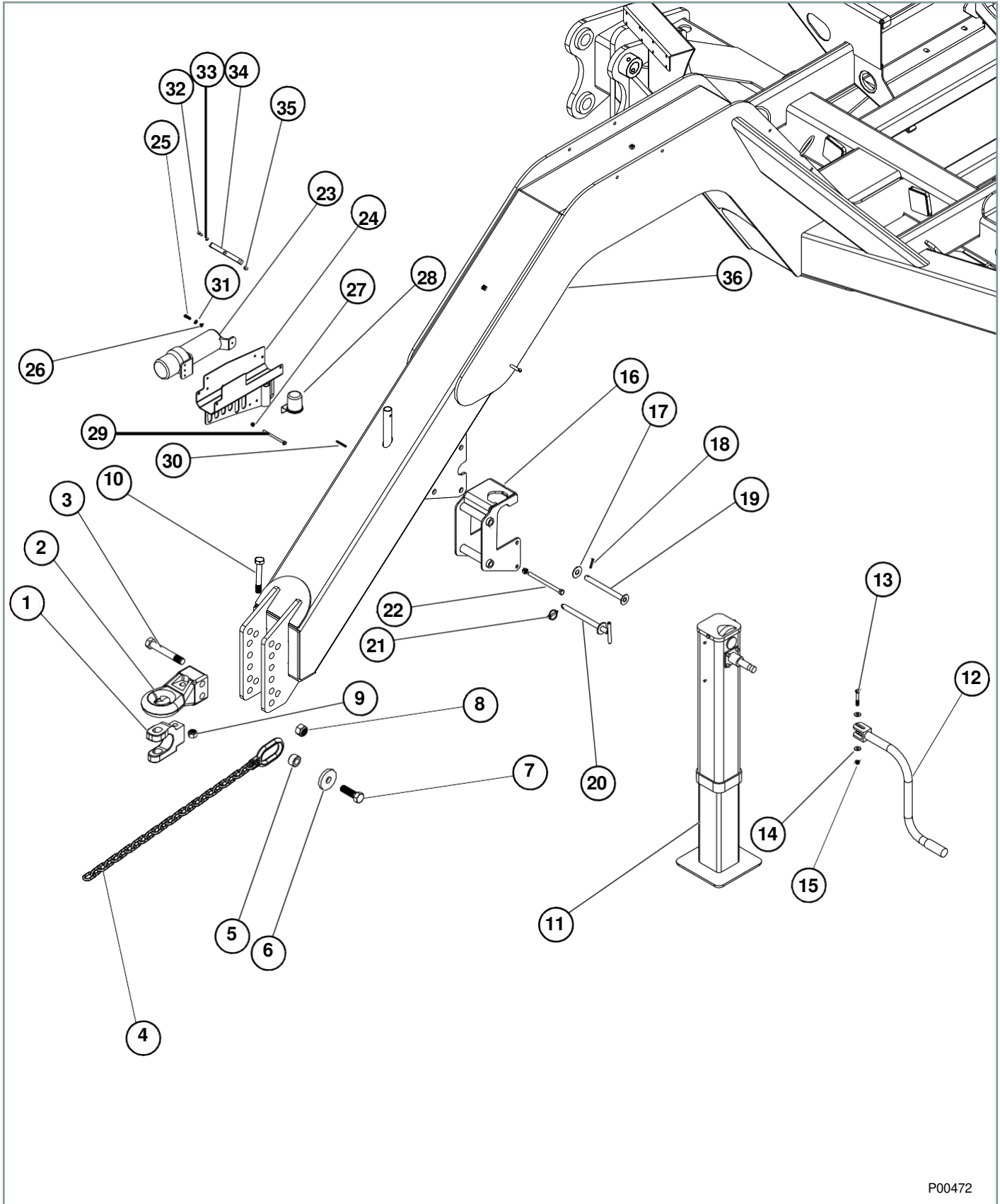

P00472

## ILLUSTRATED PARTS LIST (CONT'D)

### Cart/Main Frame Assembly Cart/Main Frame Assembly (Hitch And Jack) (Cont'd)

ITEM NO.	PART NO.	DESCRIPTION	QTY.
1	790002	HITCH, CAT 4, BOTTOM	1
2	790004	HITCH, CAT 4, TOP	1
3	590153	BOLT, 1 X 6-3/4" GRADE 5 ZP	2
4	790050	CHAIN, SAFETY, 30,000 LB	1
5	15835	DOM, SAFETY CHAIN SPACER	1
6	15829	PLATE, SAFETY CHAIN WASHER	1
7	590226	1 X 3-1/4" GRADE 5 ZP	1
8	596242M	NUT, CENTERLOCK, 1" ZP	1
9	596233M	NUT, NYLOCK, 3/4" ZP	1
10	596390M	BOLT, 3/4 X 5-1/2" GRADE 8 ZP	1
11	790045	JACK, JOST, 25,000 LB LIFTING	1
12	790046	HANDLE, JOST JACK	1
13	596131M	BOLT, 3/8 X 2-1/2" GRADE 5 ZP	1
14	596258M	WASHER, 3/8" ZP	2
15	596237M	NUT, CENTERLOCK, 3/8" ZP	1
16	15430	JACK HOLDER WELDMENT	1
17	596262M	WASHER 3/4" ZP	1
18	596683M	ROLL PIN, 1/4 X 1-1/2"	1
19	15437	3/4" LINK PIN	1
20	15440	PIN, JACK, REMOVABLE	1
21	710005	LYNCH PIN, 1/4 X 1-3/4" ZP	1
22	596164M	BOLT, 1/2 X 7" GRADE 5 ZP	2
23	750048	MANUAL HOLDER	1
24	59615810	HOSE HOLDER WELDMENT	1
25	596102M	BOLT, 1/4 X 1" GRADE 5 ZP	5
26	596767M	NUT, WHIZ, 1/4" ZP	5
27	596228M	NUT, NYLOCK, 5/16" ZP	2
28	740018	LIGHT HARNESS HOLDER	1
29	596122M	BOLT, 5/16 X 4-1/2" GRADE 5 ZP	2
30	596707M	ROLL PIN, 3/8 X 2"	1
31	596256M	1/4" FLAT WASHER ZP	5
32	596231M	NUT, NYLOCK, 1/2" ZP	AR
33	596250M	WASHER, LOCK, 3/8" ZP	4
34	15558	BRACKET, HOSE	2
35	15566	TUBE, SPACER	2
36	15700	90° APPLICATOR FRAME	1

ILLUSTRATED PARTS LIST (CONT'D)

Cart/Main Frame Assembly (Parallel Links)

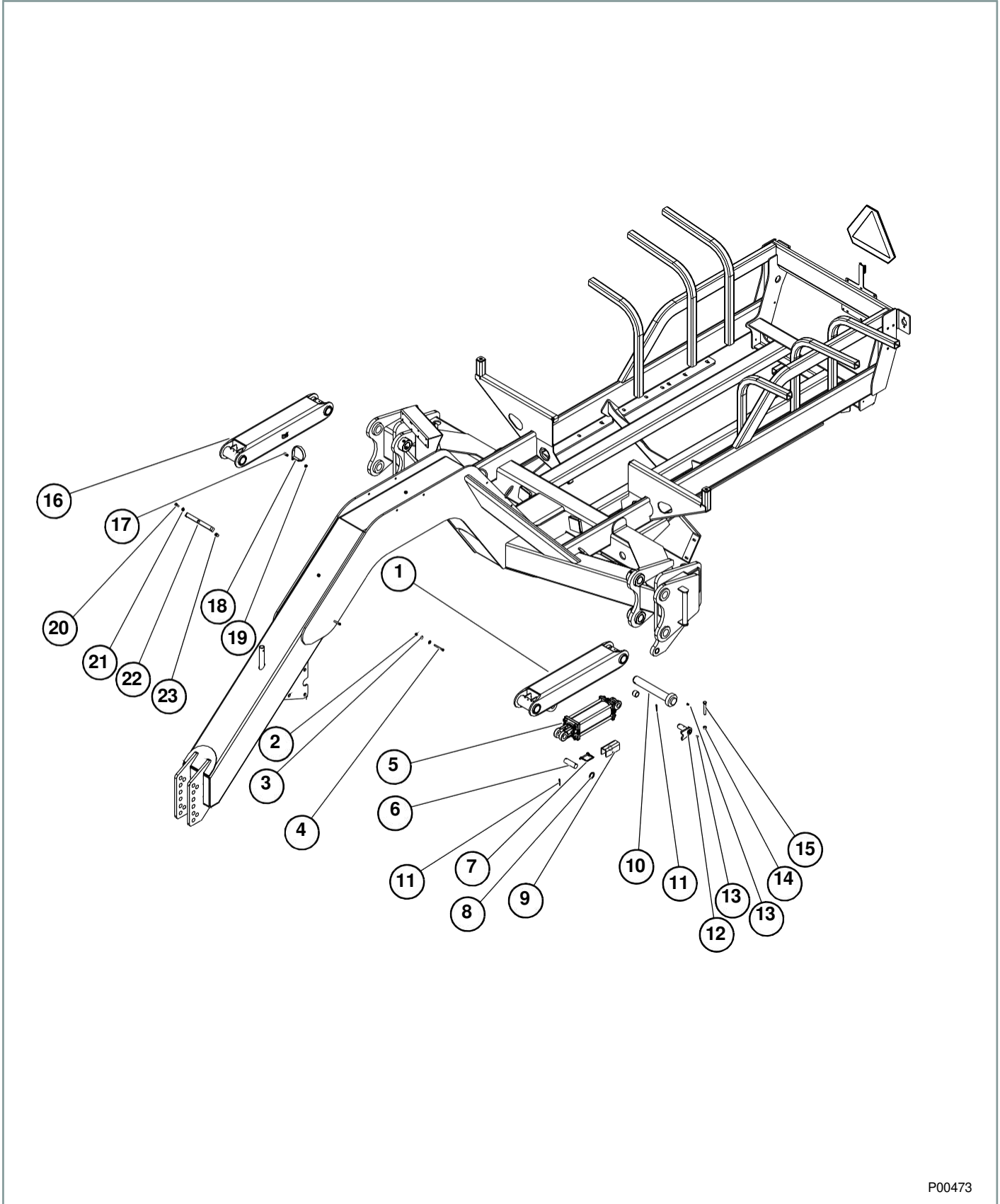

P00473

## ILLUSTRATED PARTS LIST (CONT'D)

### Cart/Main Frame Assembly (Parallel Links) 92FC84PLINK (Cont'd)

ITEM NO.	PART NO.	DESCRIPTION	QTY.
1	15756	LOWER LIFTARM	2
2	596236M	NUT, CENTERLOCK, 5/16" ZP	1
3	596257M	WASHER, 5/16" ZP	2
4	596119M	BOLT, 5/16 X 3" GRADE 5 ZP	1
5	620073	CYLINDER, 4 X 10	2
6	15158	PIN, MAIN LIFT	2
7	720001	SNAP PIN	2
8	590218	WASHER 1-1/4 149AZP	2
9	15159	5" CYLINDER STOP	2
10	15574	PIN, LIFTARM	4
11	750033	5 MM X 50 MM SPRING PIN ZP	6
12	18445	ANTI ROTATION PIN	2
13	596759	ZERK, 1/4" STRAIGHT PIPE	10
14	596239M	NUT, CENTERLOCK, 1/2" ZP	8
15	596157M	BOLT, 1/2 X 3-1/2" GRADE 5 ZP	8
16	15772	UPPER LIFTARM	2
17	596129M	BOLT, 3/8 X 1-1/2" GRADE 5 ZP	2
18	540053	P-CLAMP, 4" WITH 0.38" HOLE	2
19	596213M	NUT, 3/8" ZP	2
20	596616M	BOLT, 3/8 X 1-1/4" GRADE 5 ZP	4
21	596250M	WASHER, LOCK, 3/8" ZP	4
22	15558	BRACKET, HOSE	2
23	15566	TUBE, SPACER	2

**ILLUSTRATED PARTS LIST (CONT'D)**

**Cart/Main Frame Assembly (Wing Transport Stops)**

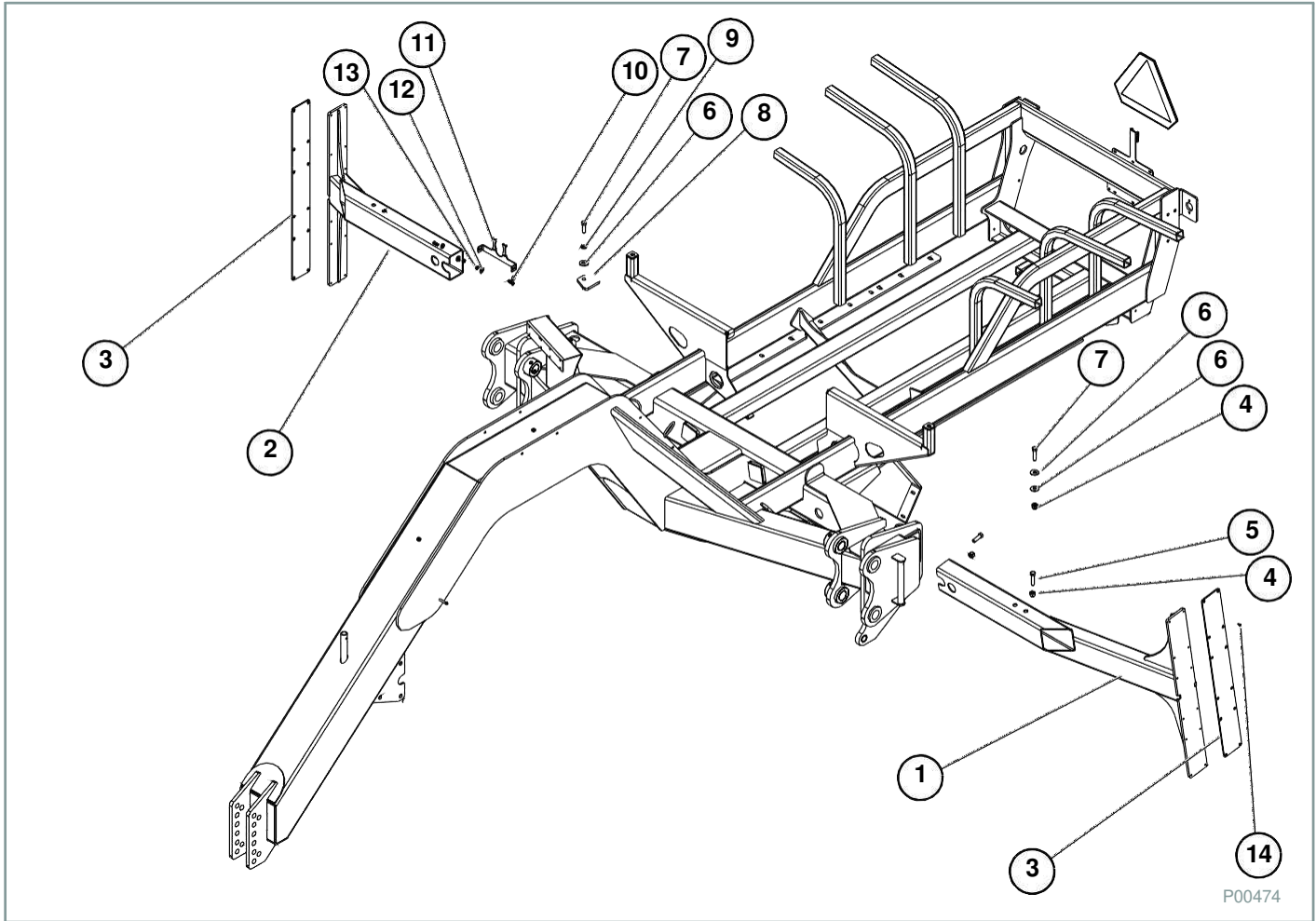

P00474

ITEM NO.	PART NO.	DESCRIPTION	QTY.
1	15900R	TRANSPORT STOP 90° RIGHT	1
2	15900L	TRANSPORT STOP 90° LEFT	1
3	750064	TRANSPORT RUB PAD	2
4	596240M	NUT, CENTERLOCK, 5/8" ZP	6
5	596170M	BOLT, 5/8 X 2" GRADE 5 ZP	2
6	596261M	WASHER, 5/8" ZP	14
7	596171M	BOLT, 5/8 X 2-1/2" GRADE 5 ZP	6
8	590023	1/2" UHMW HOLD DOWN TAB	2
9	596253M	WASHER, LOCK, 5/8" ZP	2
10	596128M	BOLT, 3/8 X1 IN. GRADE 5 ZP	2
11	59618397	MOUNT, FLOW METER	1
12	596257M	WASHER, 5/16" ZP	2
13	596236M	NUT, CENTERLOCK, 5/16" ZP	1
14	596581M	RIVET	24



# ILLUSTRATED PARTS LIST (CONT'D)

## Axle Assemblies

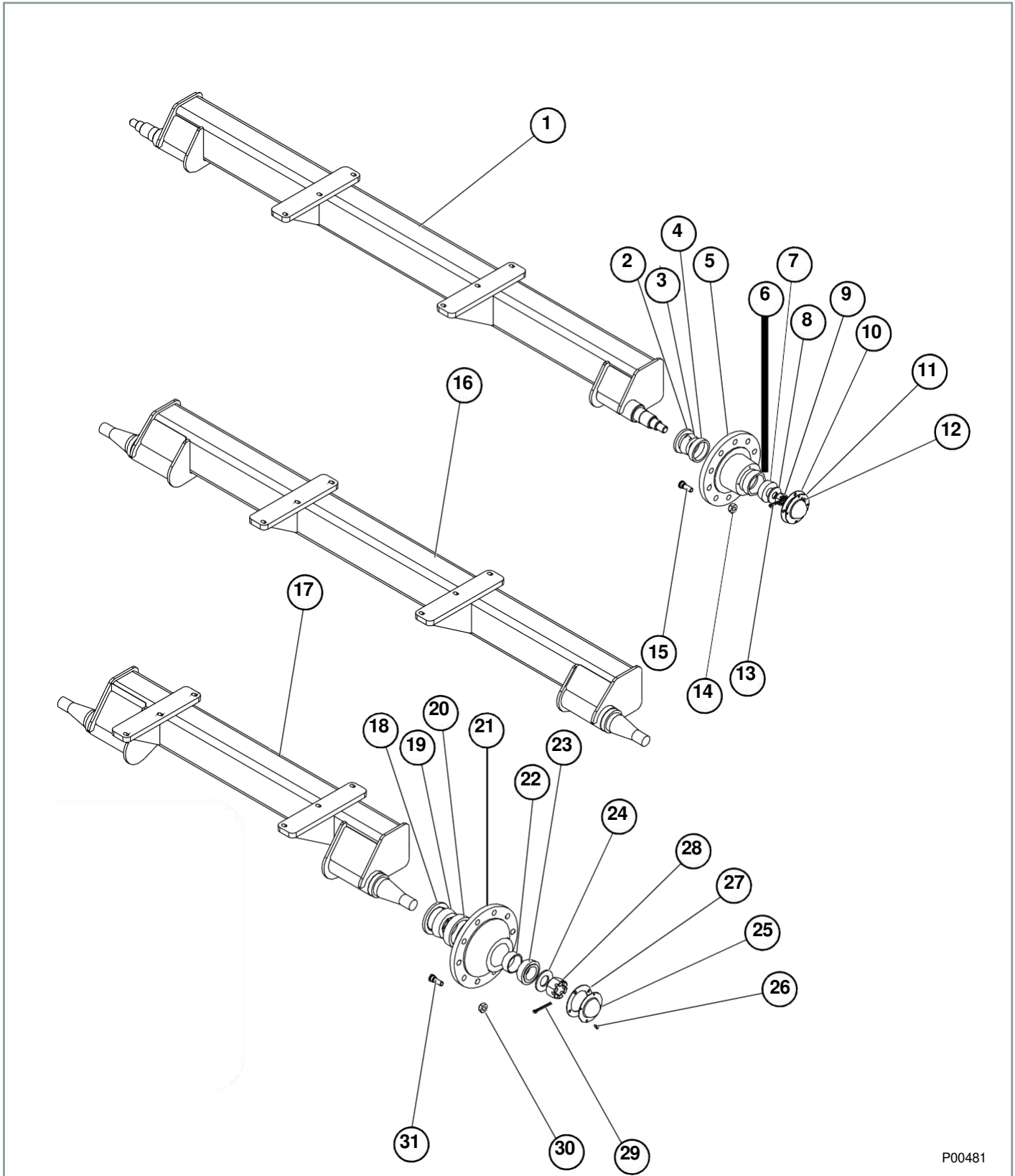

P00481



## ILLUSTRATED PARTS LIST (CONT'D)

### Axle Assemblies (Cont'd)

ITEM NO.	PART NO.	DESCRIPTION	QTY.
1	16695	AXLE 60' SIDE FOLD 15000# 120" WHEEL TRACK 1800 GALLON TANK	1
	16888	AXLE SINGLE 15000# 88" WHEEL TRACK (OPTIONAL) 1800 GALLON TANK	
2	730013	SEAL 10 BOLT (906497 CR30087)	2
3	730054	CONE INNER (910333/39585)	2
4	1678	CUP INNER (910331/39520)	2
5	730002	HUB 10 BOLT W/CUPS	2
6	730074	CUP OUTER (910332/453A)	2
7	730012	CONE OUTER (910334/460)	2
8	730018	WASHER SPINDLE (913632)	2
9	730014	NUT SPINDLE 1.25-12 TPI	2
10	730016	GASKET HUB CAP	2
11	730072	HUB CAP Q-871 HUB	2
12	596113M	BOLT HEX HEAD 5/16 X 1/2 GRADE 5 ZP	8
13	730015	COTTER PIN	2
14	730051	NUT WHEEL (913571)	20
15	730045	STUD WHEEL (953033)	20
16*	18430	AXLE SINGLE 2400 GALLON 20000# 480/80R50 1.5" OFFSET WHEEL	1
17	10913	AXLE, SPACER DUAL, 62 1/2 IN. -120 IN. WHEEL TRACK (OPTIONAL)	1
	10910	AXLE, SPACER DUAL, 80 IN. -120 IN. WHEEL TRACK (OPTIONAL)	
	10907	AXLE, SPACER DUAL, 88 IN. -132 IN. WHEEL TRACK (OPTIONAL)	
18	730041	SEAL NI906979	2
19	730043	CONE INNER NI910346	2
20	730012	CUP INNER NI910334	2
21	730060	HUB 10 Q881 W/CUPS	2
22	1679	CUP OUTER NI910384	2
23	730037	CONE OUTER NI0910347	2
24	730040	WASHER SPINDLE Q9881	2
25	730038	HUB CAP NI909921	2
26	596113M	BOLT HEX HEAD 5/16 X 1/2 GRADE 5 ZP	2
27	730061	GASKET HUB CAP	2
28	730056	NUT CASTLE NI913571	2
29	730042	COTTER PIN Q881 HUB	2
30	730051	NUT WHEEL NI913571	20
31	NI953035	STUD WHEEL NI953035 3/4-16 X 3.5"	20

\* - Uses parts 18 through 31

**NOTE: Track assemblies have their own parts and operator's manuals.**

**ILLUSTRATED PARTS LIST (CONT'D)**

**Axle Assembly Options**

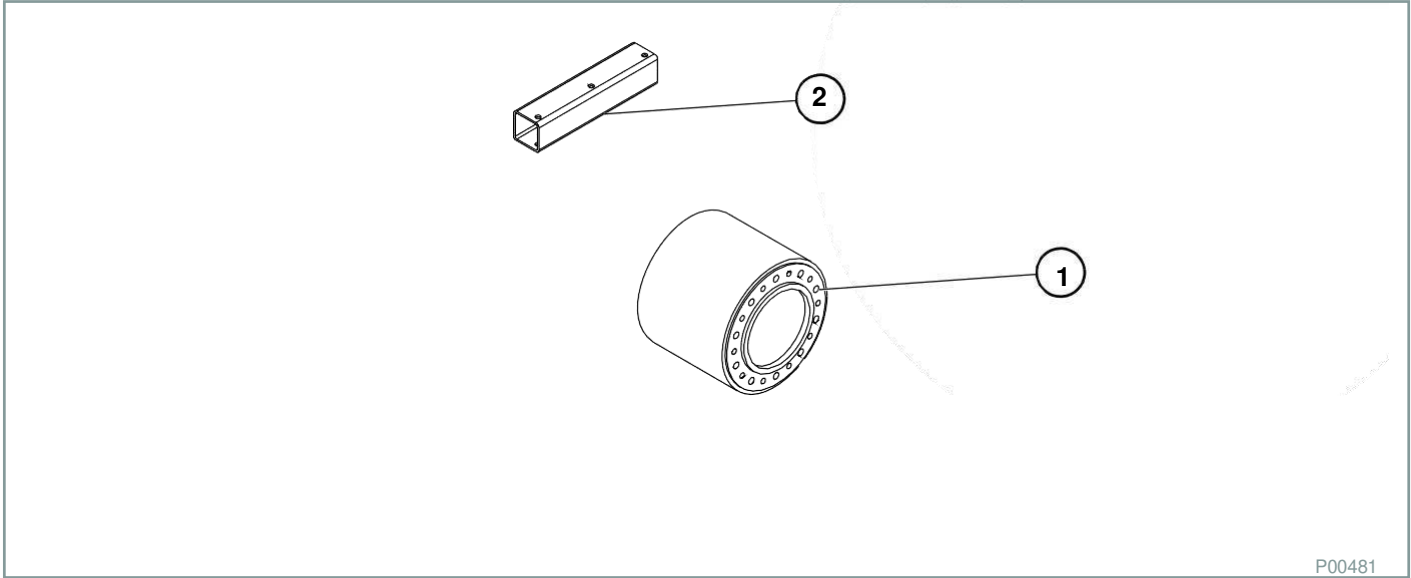

P00481

ITEM NO.	PART NO.	DESCRIPTION	QTY.
1	710030	SPACER DUAL 30 IN. ROWS, 13.75" SPACER (OPTIONAL)	2
	710032	SPACER DUAL 22 IN. ROWS, 7" SPACER	
	710031	SPACER DUAL 20 IN. ROWS, 5" SPACER	
NS	18360	AXLE, 72 IN. SPACING, 15,000 LB	1
	18174	AXLE, 76 IN. SPACING, 15,000 LB	
	16930	AXLE, 80 IN. SPACING, 15,000 LB	
	18433	AXLE, 132 IN. SPACING, 15,000 LB	
	18435	AXLE, 88 IN. SPACING, 20,000 LB	
	18416	AXLE, 132 IN. SPACING, 20,000 LB	
2	16457	AXLE SPACER 54" TIRE	2



**ILLUSTRATED PARTS LIST (CONT'D)**

**Tire And Rim**

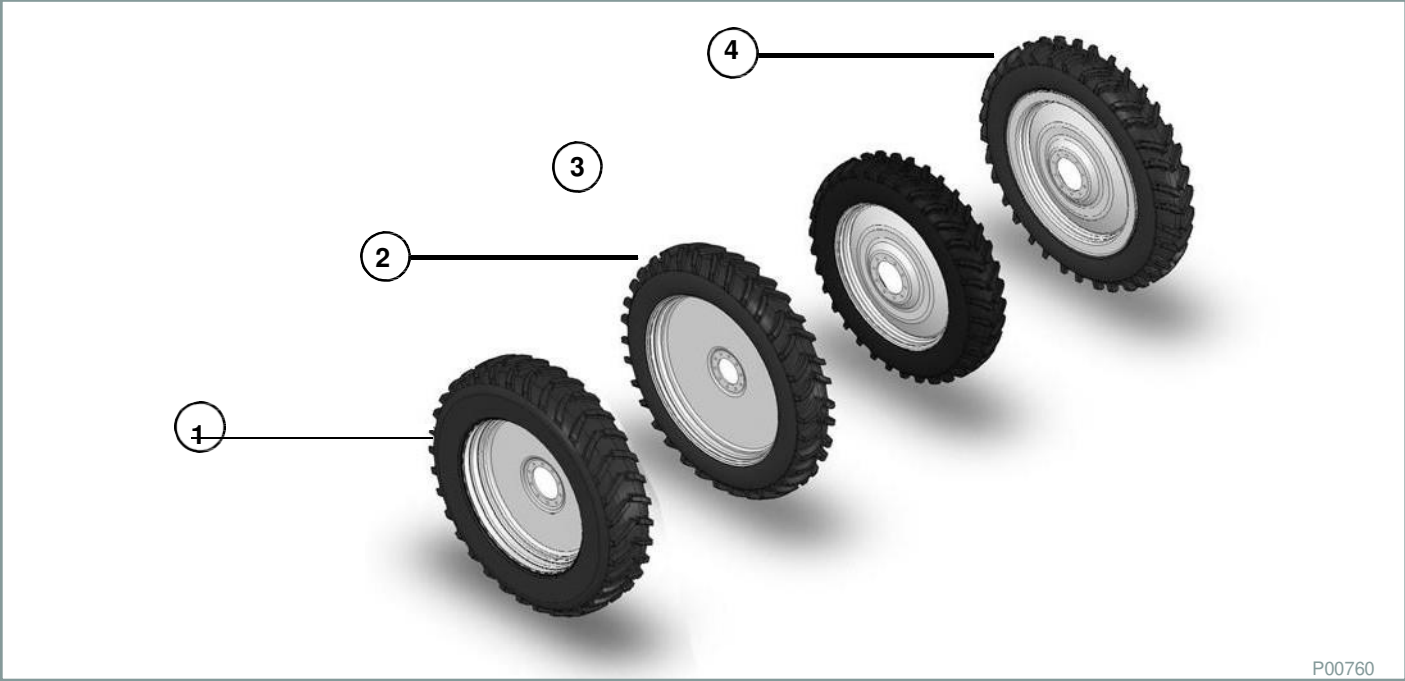

P00760

## ILLUSTRATED PARTS LIST (CONT'D)

### Tire And Rim (Cont'd)

ITEM NO.	PART NO.	DESCRIPTION	TIRE PRESSURE	QTY.
1	700087	TIRE AND WHEEL 480 / 80R50 LR 176 YELLOW LH STD. 2400 GALLON	73 PSI (503 KPA)	1
	700085	TIRE AND WHEEL 480 / 80R50 LR 176 SILVER LH STD. 2400 GALLON		1
	700088	TIRE AND WHEEL 480 / 80R50 LR 176 YELLOW RH STD. 2400 GALLON		1
	700086	TIRE AND WHEEL 480 / 80R50 LR 176 SILVER RH STD. 2400 GALLON		1
2	700124	TIRE AND WHEEL 380 / 90R54 LR 170 YELLOW LH OPTIONAL	75 PSI (517 KPA)	1
	700126	TIRE AND WHEEL 380 / 90R54 LR 170 SILVER LH OPTIONAL		1
	700125	TIRE AND WHEEL 380 / 90R54 LR 170 YELLOW RH OPTIONAL		1
	700127	TIRE AND WHEEL 380 / 90R54 LR 170 SILVER RH OPTIONAL		1
3	700135	TIRE AND WHEEL 380 / 90R46 LR 149 YELLOW DUAL LH OPTIONAL	255 kPa (2.55 bar) (37 psi)	2
	700139	TIRE AND WHEEL 380 / 90R46 LR 149 SILVER DUAL LH OPTIONAL	Inner	2
	700136	TIRE AND WHEEL 380 / 90R46 LR 149 YELLOW DUAL RH OPTIONAL	227 kPa (2.28 bar) (33 psi)	2
	700140	TIRE AND WHEEL 380 / 90R46 LR 149 SILVER DUAL RH OPTIONAL	Outer	2
4	700137	TIRE AND WHEEL 380 / 90R54 LR 152 YELLOW DUAL LH OPTIONAL	255 kPa (2.55 bar) (37 psi)	2
	700141	TIRE AND WHEEL 380 / 90R54 LR 152 SILVER DUAL LH OPTIONAL		
	700138	TIRE AND WHEEL 380 / 90R54 LR 152 YELLOW DUAL RH OPTIONAL	227 kPa (2.28 bar) (33 psi)	2
	700142	TIRE AND WHEEL 380 / 90R54 LR 152 SILVER DUAL RH OPTIONAL		

**NOTE: Tire pressure is directly linked to LRXXX (bold italic). Make sure of the load rating of the tire before adding any air to the tire.**

ILLUSTRATED PARTS LIST (CONT'D)

Center Wing Assembly

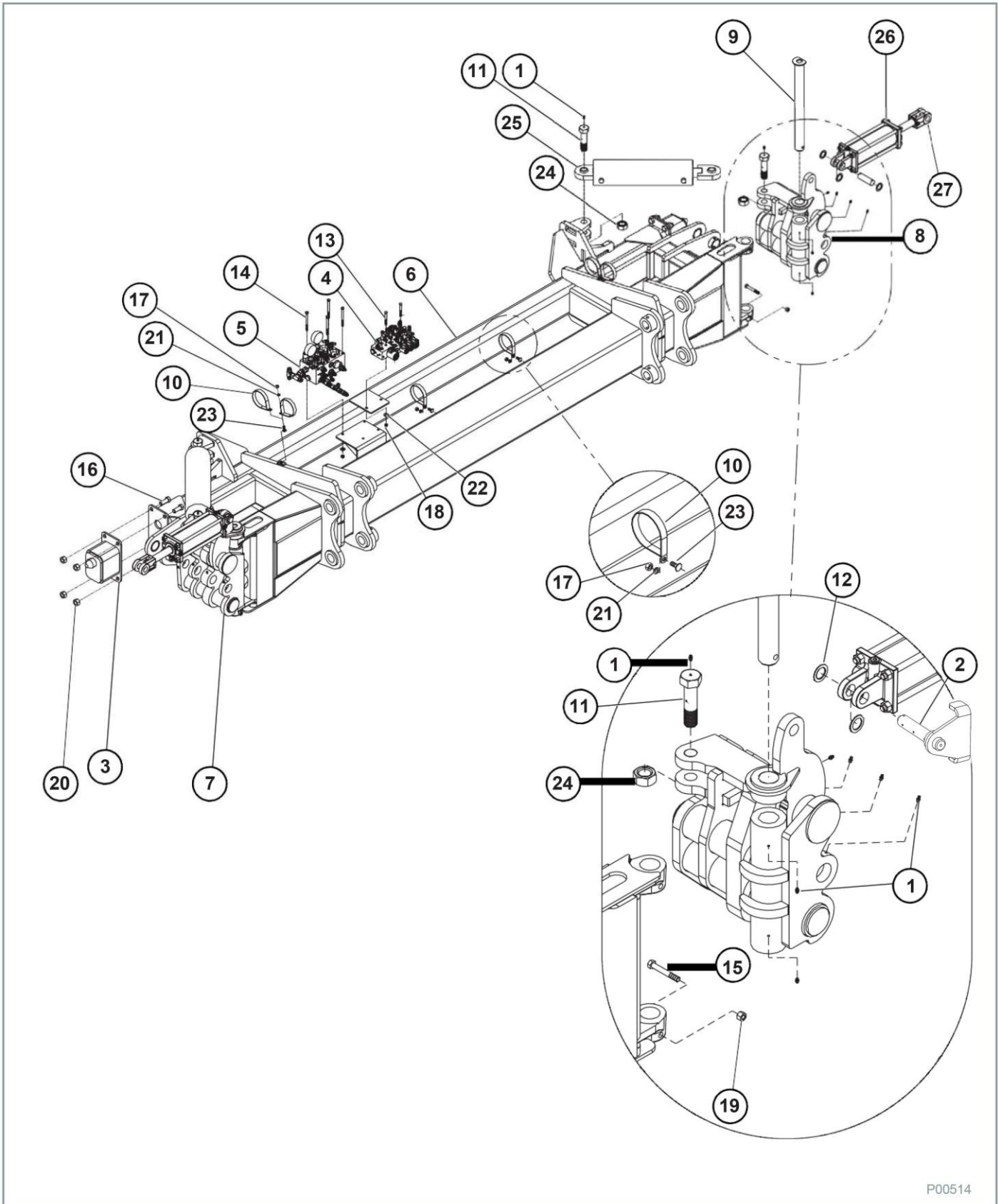

P00514

## ILLUSTRATED PARTS LIST (CONT'D)

### Center Wing Assembly (Cont'd)

ITEM NO.	PART NO.	DESCRIPTION	QTY.
1	759	ZERK, 1/4-28 STRAIGHT	16
2	15158	PIN, MAIN LIFT	2
3	23385	ADJUSTABLE WING STOP	2
4	15849	90' FOLD VALVE WITH FITTINGS	1
5	15850	90' LIFT ASSIST BLOCK	1
6	15517	WELDMNT, CENTER SECTION 90'	1
7	23422L	FLEX HINGE WELDMENT	1
8	23422R	FLEX HINGE WELDMENT	1
9	23476	VERTICAL FLEX HINGE PIN	2
10	540053	P-CLAMP, 4 IN. W/ 3/8 IN. HOLE	6
11	590183	BOLT, 1-1/4 IN. X 5 IN. MACHINED	4
12	590218	WASHER, 1-1/4 IN. 14GA ZP	6
13	596132M	BOLT, HH 3/8-16 X 3 GR5 MAGNI	2
14	596135M	BOLT, HH G5 3/8 X 4-1/2 MAGNI	4
15	596157M	BOLT, HH 1/2X3-1/2 GR5 MAGNI	2
16	596184M	BOLT, HH 3/4X2 GR5 MAGNI	8
17	596237M	NUT, HEX 3/8-16 CENTERLOCK MAGNI	4
18	596239M	NUT, CENTERLOCK 3/8 1/2-13 MAGNI	6
19	596241M	NUT, CENTERLOCK, 3/4-10 MAGNI	2
20	596250M	LOCKWASHER 3/8 MAGNI	8
21	596759M	ZERK 1/4 X 28 STR.	4
22	596258M	WASHER, FLAT 3/8 MAGNI	6
23	596592M	BOLT, CARRIAGE, 3/8-16 X 1 IN. MAGNI	4
24	596724M	NUT, CENTERLOCK, 1-1/4 IN. MAGNI	4
25	620046	FOLD CYLINDER	2
26	620073	4 X 10 CYLINDER	2
27	620086	CLEVIS ADI HARPENED	2

ILLUSTRATED PARTS LIST (CONT'D)

Inner Wing Assembly (Left And Right)

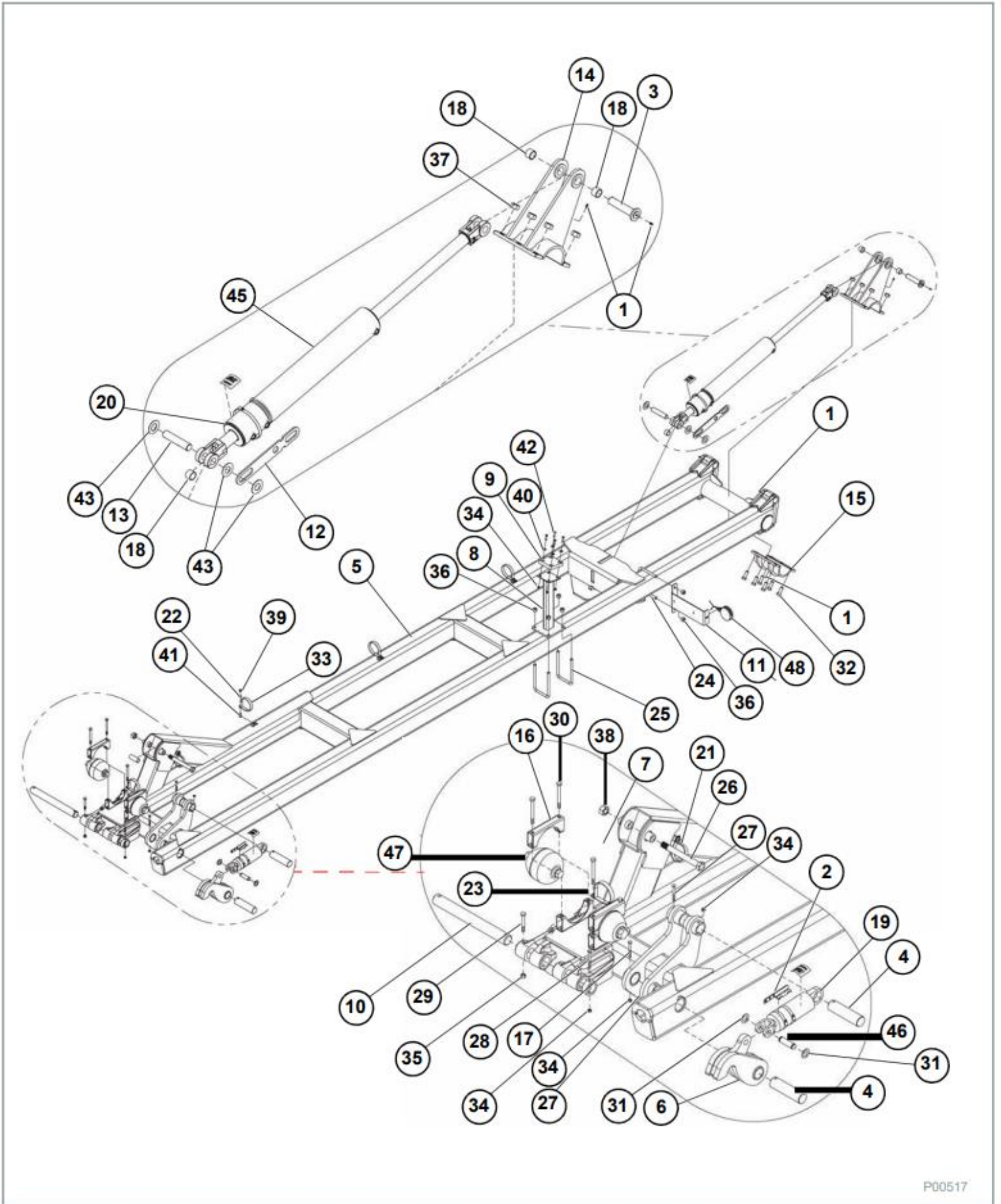



## ILLUSTRATED PARTS LIST (CONT'D)

### Inner Wing Assembly (Left And Right) (Cont'd)

ITEM NO.	PART NO.	DESCRIPTION	QTY.
1	759	ZERK, 1/4-28 STRAIGHT	5
2	15505	PLATE, PROX SENSOR	1
3	15559	WLDMNT, FLIP CYL PIN	1
4	15585	PIN, WING LATCH	2
5	15601	WELDMENT, LH MAIN WING	1
	15726	WLDMNT, RH MAIN WING (NS)	1
6	15630	LATCH WLDMNT	1
7	15644	DOM, SPACER	1
8	15660	BOLT ON WING REST	1
9	15669	RUBBER BUMPER	1
10	15791	PIN, MAIN ATTACH	1
11	15816	PLATE, LIGHT MOUNT	1
12	15857	PLATE, CYLINDER ANTI ROTATE	1
13	15859	ANTI ROTATE PIN	1
14	28932	WLDMNT, FLIP LINKAGE (LEFT)	2
15	15930	WLDMNT, LINKAGE BASE	2
16	16654	TUBE, ACCUMULATOR MOUNT	2
17	17209	TUBE, 2 IN. COLLAR	1
18	530291	BUSHING, 1 1/4 IN. I.D. X 1 IN. LG	3
19	620026	CYLINDER LATCH	2
20	540021	CLAMP, 4 1/8 - 7 IN.	1
21	540052	P-CLAMP, 3 IN. W/3/8 IN. HOLE	1
22	540053	P-CLAMP, 4 IN. W/3/8 IN. HOLE	3
23	540054	P-CLAMP, 4 IN. W/1/2 IN. HOLE	1
24	590061	U-BOLT, 5/8 X 7-1/16 IN. X 6-1/2 IN., ZP	1
25	590177	U-BOLT 5X7X5/8	2

**ILLUSTRATED PARTS LIST (CONT'D)**

**Inner Wing Assembly (Left And Right) (Cont'd)**

<b>ITEM NO.</b>	<b>PART NO.</b>	<b>DESCRIPTION</b>	<b>QTY.</b>
26	590225	BOLT, 1 X 9.25 IN., GR8 ZP	1
27	596132M	BOLT, HH 3/8-16 X 3 GR5 MAGNI	2
28	596133M	BOLT, HH G5 3/8 X 3-1/2 MAGNI	1
29	596157M	BOLT, HH 1/2X3-1/2 GR5 MAGNI	1
30	596160M	BOLT, HH 1/2X5 GR5 MAGNI	4
31	596179M	BUSHING, MACHINED 1 IN. X 14GA MAGNI	2
32	596184M	BOLT, HH 3/4X2 GR5 MAGNI	6
33	596213M	NUT, HEX 3/8-16 MAGNI	4
34	596237M	NUT, CENTERLOCK 3/8 MAGNI	7
35	596239M	NUT, CENTERLOCK, 1/2-13 MAGNI	1
36	596240M	NUT, CENTERLOCK, 5/8-11 MAGNI	6
37	596241M	NUT, CENTERLOCK 3/4-10 MAGNI	6
38	596242M	NUT, CENTERLOCK, 1 IN. MAGNI	1
39	596250M	LOCKWASHER 3/8 MAGNI	4
40	596258M	WASHER, FLAT 3/8 MAGNI	4
41	596592M	BOLT, CARRIAGE, 3/8-16 X 1 IN. MAGNI	4
42	596635M	BOLT, HH 3/8-16 X 1-1/4 MAGNI	4
43	596744M	BUSHING, MACHINED, 1-1/4 ID	4
44	596771M	NUT, HEX FLANGE 1/2-13 MAGNI	4
45	620027	CYLINDER, FLIP WING	1
46	620072	PIN, CYLINDER, 1 X 3-3/8 IN.	1
47	630020	ACCUMULATOR, 85 CU.	2
48	740024	LIGHT, AMBER, PED. MOUNT	1
49	540020	CLAMP 3-1/2 SS	2



ILLUSTRATED PARTS LIST (CONT'D)

Outer Wing Assembly (Left And Right)

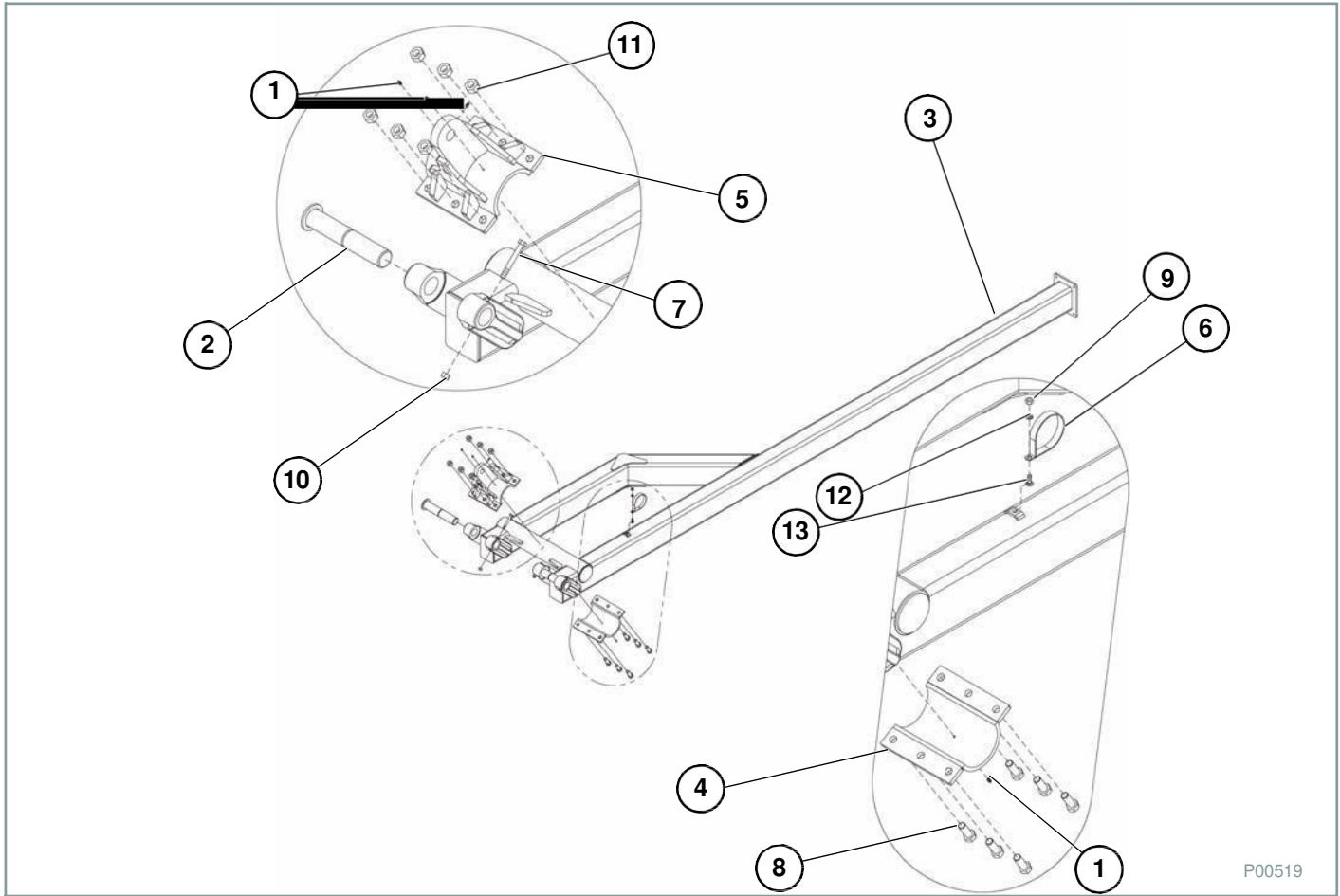

## ILLUSTRATED PARTS LIST (CONT'D)

### Outer Wing Assembly (Left And Right) (Cont'd)

ITEM NO.	PART NO.	DESCRIPTION	QTY.
1	759	ZERK, 1/4-28 STRAIGHT	4
2	15653	WLDMT, FLIP HINGE PIN	2
3	15870L	WLDMT, LH FLIP WING 90 FT.	1
	15870R	WLDMT, RH FLIP WING 90 FT.(NS)	1
	15880L	WLDMT, LH FLIP WING 80 FT. (NS)	1
	15880R	WLDMT, RH FLIP WING 80 FT.(NS)	1
4	15930	WLDMT, LINKAGE BASE	1
5	28930	WLDMT, FLIP LINKAGE	1
6	540053	P-CLAMP, 4 IN. W/3/8 IN. HOLE	1
7	596158M	BOLT, HH 1/2X4 GR5 MAGNI	1
8	596184M	BOLT, HH 3/4X2 GR5 MAGNI	6
9	596213M	NUT, HEX 3/8-16 MAGNI	1
10	596239M	NUT, CENTERLOCK, 1/2-13 MAGNI	2
11	596241M	NUT, CENTERLOCK 3/4-10 MAGNI	6
12	596250M	LOCKWASHER 3/8 MAGNI	1
13	596592M	BOLT, CARRIAGE, 3/8-16 X 1 IN. MAGNI	1
NS	15380	WING EXTENSION 20 IN. (37 COULTER 30 IN. SP 90' & 33 COULTER 30 IN. SP 80' BAR)	1
NS	596153M	BOLT, HEX HEAD 1/2 X 1-1/2 GR5	4
NS	596239M	NUT, CENTERLOCK 1/2 IN.	4

ILLUSTRATED PARTS LIST (CONT'D)

Lift Assist And Swivel Wheel Assembly

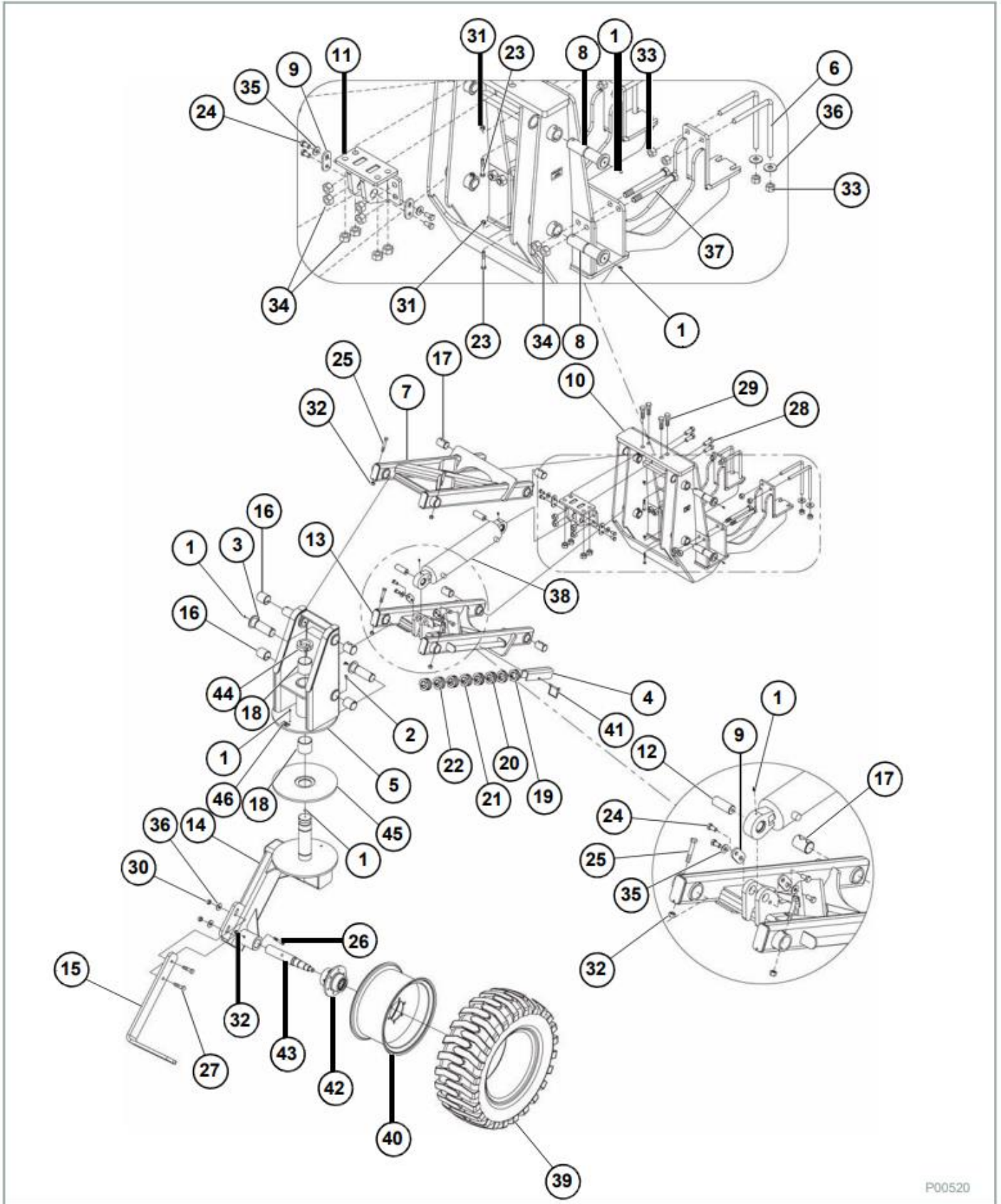

## ILLUSTRATED PARTS LIST (CONT'D)

### Lift Assist And Swivel Wheel Assembly (Cont'd)

ITEM NO.	PART NO.	DESCRIPTION	QTY.
1	759	ZERK, 1/4-28 STRAIGHT	11
2	761	ZERK, 90°, 1/4 IN. STRAIGHT PIPE	3
3	15737	PIN, LIFT ASSIST, WLDMT	4
4	15771	9 IN. CYLINDER STOP	1
5	15861	LIFT, FRONT WLDMT	1
6	15969	L-BOLT, 5/8-11	4
7	15990	LINKAGE, UPPER WLDMT	1
8	15993	PIN, LINKAGE, WLDMT	4
9	15998	PLATE, PIN END	4
10	23440	LIFT ASSIST MOUNT, WLDMT	1
11	23444	CYL BASE END MOUNT, WLDMT	1
12	23447	PIN, LIFT ASSIST ROD	2
13	23448	LINKAGE, LOWER, WLDMT	1
14	23450	CASTER ARM, WLDMT	1
15	23774	BRACKET, SCRAPER	1
16	530351	BUSHING, CONNEX SPRING, 2.25	4
17	530352	BUSHING, CONNEX SPRING, 1.75	4
18	530353	BUSHING, CONNEX 3IDX3LG	2
19	590205	3/4 IN. CYLINDER STOP	2
20	590206	1 IN. CYLINDER STOP	2
21	590207	1-1/4 IN. CYLINDER STOP	2
22	590208	1-1/2 IN. CYLINDER STOP	2
23	596131M	BOLT, HH 3/8-16X2-1/2 GR5 MAGNI	4

**ILLUSTRATED PARTS LIST (CONT'D)**

**Lift Assist And Swivel Wheel Assembly (Cont'd)**

<b>ITEM NO.</b>	<b>PART NO.</b>	<b>DESCRIPTION</b>	<b>QTY.</b>
24	596152M	BOLT, HH 1/2X1 GR5 MAGNI	8
25	596156M	BOLT, HH 1/2X3 GR5 MAGNI	4
26	596158M	BOLT, HH 1/2X4 GR5 MAGNI	1
27	596171M	BOLT, HH 5/8-11X2.5 GR5 MAGNI	2
28	596184M	BOLT, HH 3/4X2 GR5 MAGNI	4
29	596185M	BOLT, HH 3/4-10X2-1/2 MAGNI	4
30	596232M	NUT, HEX NYLOCK 5/8-11 MAGNI	2
31	596237M	NUT, CENTERLOCK 3/8 MAGNI	4
32	596239M	NUT, CENTERLOCK, 1/2-13 MAGNI	5
33	596240M	NUT, CENTERLOCK, 5/8-11 MAGNI	8
34	596241M	NUT, CENTERLOCK 3/4-10 MAGNI	16
35	596260M	WASHER, FLAT 1/2 MAGNI	4
36	596261M	WASHER, FLAT 5/8 MAGNI	6
37	596486M	BOLT, HH 3/4-10 X 7-1/2 MAGNI	8
38	620088	CYLINDER, CASTER LIFT	1
39	700101	TIRE, LIFT ASSIST	1
40	700156	RIM, 16.5X9.75 DUP 6 HOLES	1
41	720001	PIN, SNAP, 5/16	1
42	730098	HUB, 6 BOLT	1
43	730099	SPINDLE, 6 BOLT HUB, 6,000 LB CAP	1
44	750041	CLAMP, BOLT-ON, 2.5 IN. ID	1
45	750044	PLATE, BEARING	1
46	800014	DECAL, GREASE PIVOT POINTS	3
NS	730097	FLANGE LUG BOLT 9/16-18	6





**ILLUSTRATED PARTS LIST (CONT'D)**

**Six Bolt Hub Assembly**

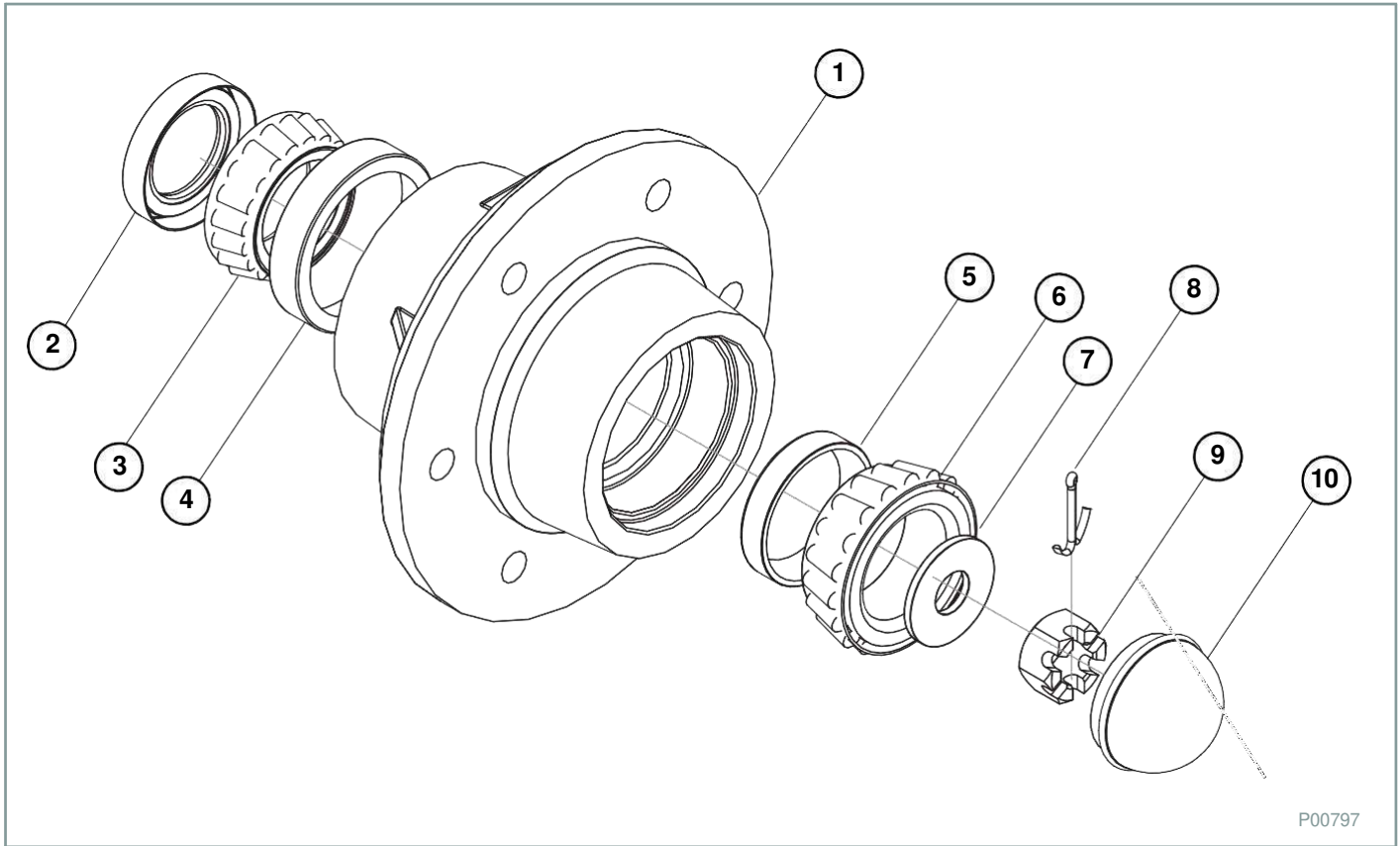

P00797

ITEM NO.	PART NO.	DESCRIPTION	QTY.
1*	730098	HUB COMPLETE	1
2	730031	SEAL	1
3	730021	CONE INNER LM501310	1
4	730057	CUP INNER LM501310	1
5	NI67010	CUP OUTER	1
6	730032	CONE OUTER LM67048	1
7	730034	WASHER	1
8	730033	COTTER PIN	1
9	730088	NUT	1
10	730044	HUB CAP	1

\* - Complete Hub contains Items 2 through 10.

**ILLUSTRATED PARTS LIST (CONT'D)**

**Gauge Wheel Assembly 26860 / 26861**

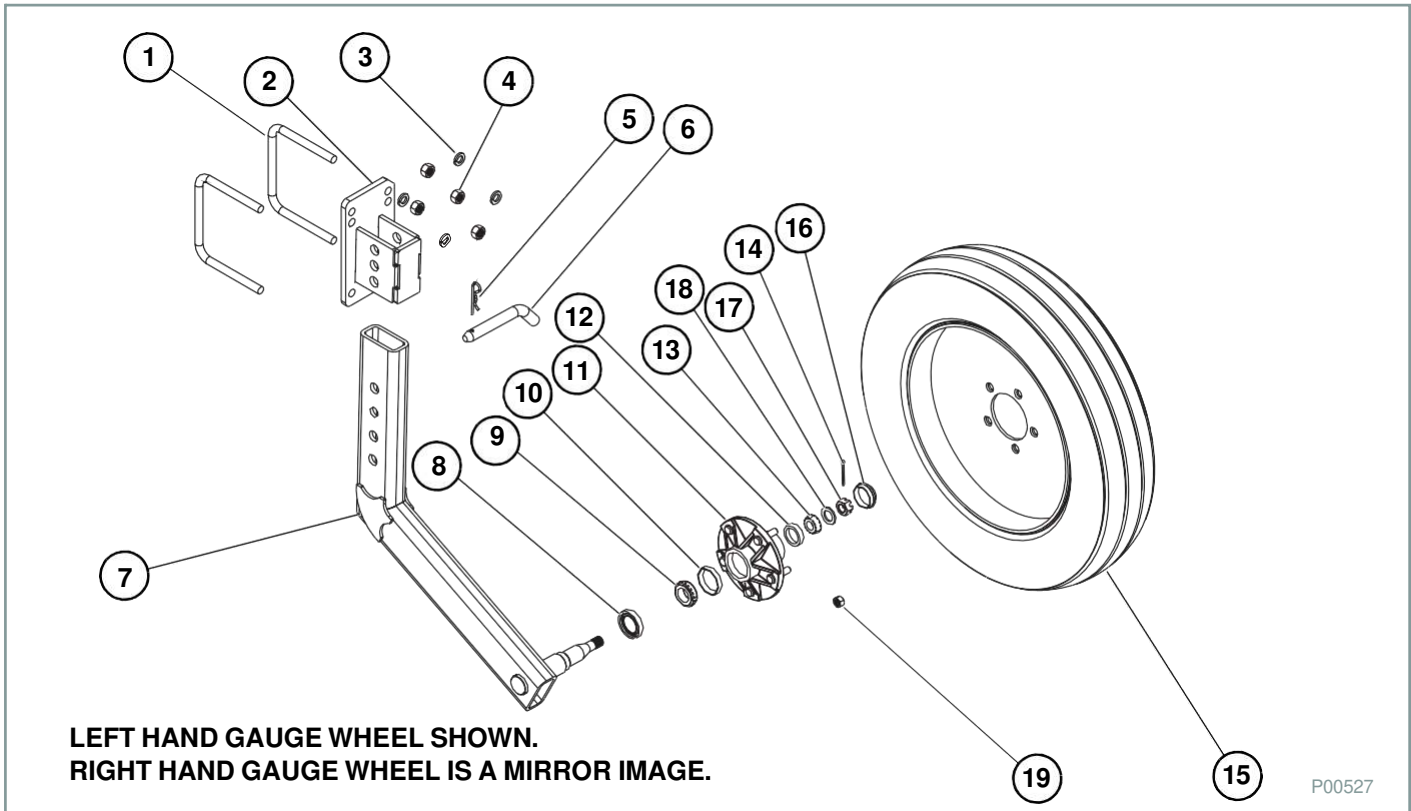

ITEM NO.	PART NO.	DESCRIPTION	QTY.
1	590061	U-BOLT 5 X 7	2
2	22050L	GAUGE WHEEL MOUNT LH	1
NS	22050R	GAUGE WHEEL MOUNT RH (NS)	1
3	596253M	LOCKWASHER 5/8 IN. MAGNI	4
4	596216M	NUT 5/8 IN. MAGNI	4
5	596285M	CLIP SPRING LOCKING	1
6	19061	PIN GAUGE WHEEL MOUNT	1
7	22045L	GAUGE WHEEL ARM LH	1
NS	22045R	GAUGE WHEEL ARM RH (NS)	AR
8	730021	SEAL GREASE	1
9	730032	BEARING INNER	1
10	N910257	CUP BEARING INNER	1
11	730026	HUB 5 BOLT W CUPS	1
12	N910258	CUP BEARING OUTER	1
13	730036	BEARING OUTER	1
14	730033	PIN COTTER	1
15	700134	TIRE/WHEEL 6.70 X 15 YELLOW	1
	700133	TIRE/WHEEL 6.70 X 15 SILVER	AR
16	730044	HUB CAP	1
17	730035	NUT CASTLE	1
18	730034	WASHER, SPINDLE NUT	1
19	730030	NUT, WHEEL 1/2 IN. FINE THREAD	5

ILLUSTRATED PARTS LIST (CONT'D)

FAST Coulter Assembly

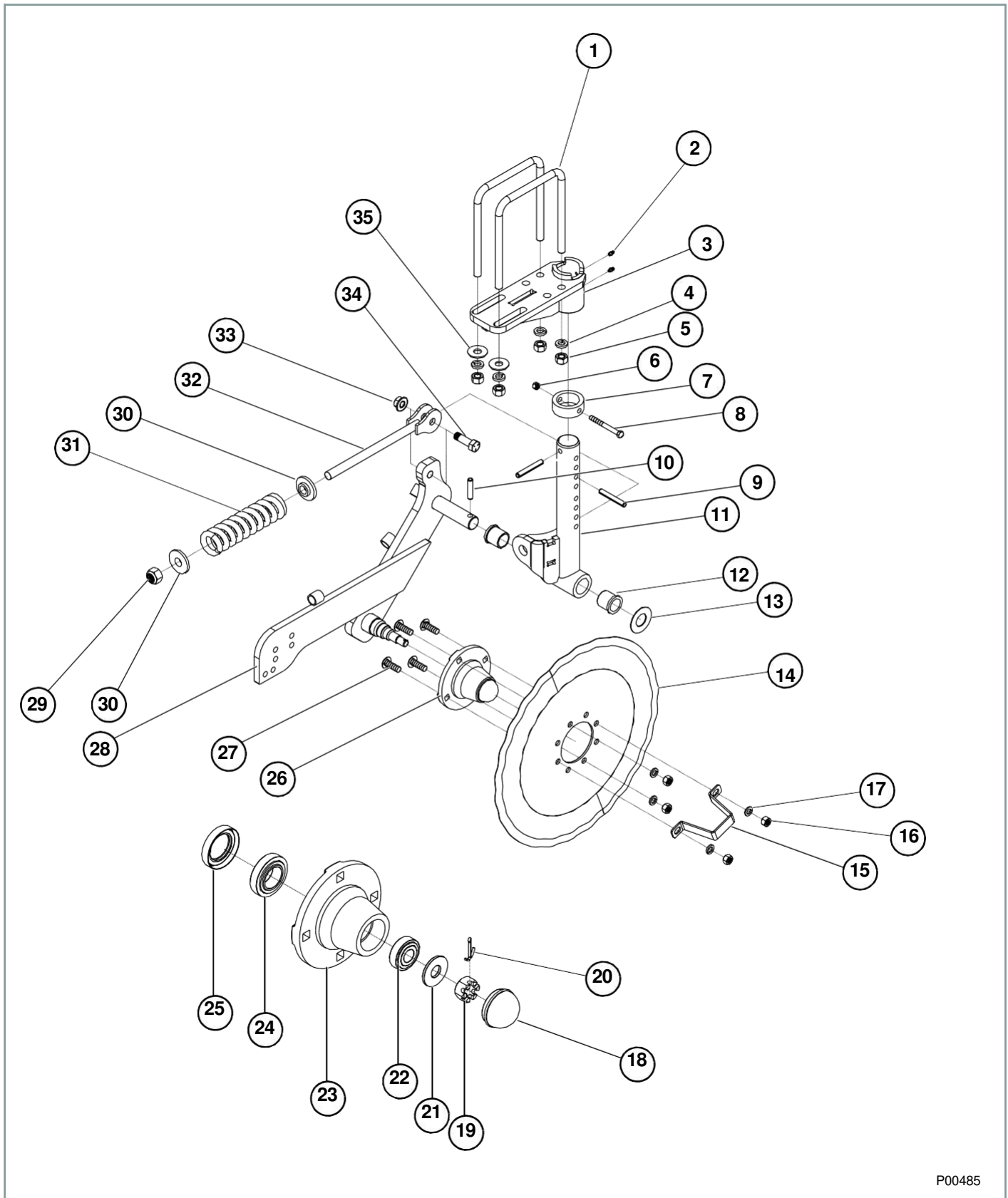

P00485

## ILLUSTRATED PARTS LIST (CONT'D)

### FAST Coultter Assembly 34470 / 34471 (Cont'd)

ITEM NO.	PART NO.	DESCRIPTION	QTY.
1	590108	U-BOLT, 7 X 7 X 5/8, 7 X 7 BAR	AR
NS	590177	U-BOLT, 7 X 5 X 5/8, 5 X 7 BAR	AR
2	759	ZERK, GREASE 1/4028TPI	2
3	17225	COULTER MOUNT	1
4	596253M	WASHER LOCK 5/8 IN.	4
5	596216M	NUT, HEX HEAD 5/8 IN.	4
6	596237M	NUT, HEX HEAD 3/8 IN. CENTER LOCK	1
7	17209	COLLAR	1
8	596133M	BOLT, HEX HEAD 3/8 X 3-1/2 GRADE 5	1
9	596739M	PIN, ROLL 7/16 X 3	2
10	596740M	PIN, ROLL 7/16 X 2	1
11	17240	2 IN. SHANK WELDMENT	1
12	530328	FLANGED BUSHING	2
13	596744M	WASHER 14 GA X 1-1/4 IN.	1
14	750014	COULTER BLADE	1
15	17214	HUB CAP RETAINER BRACKET	1
16	596215M	NUT, HEX HEAD 1/2 IN.	4
17	596251M	WASHER LOCK 1/2 IN.	4
18	730044	HUB DUST CAP	1
19	730088	NUT, CASTLE 5/8 IN.	1
20	730033	PIN COTTER	1
21	730034	WASHER, HUB	1
22	730036	BEARING	1
23	NIN285001	HUB 4 BOLT	1
24	730032	BEARING	1
25	730031	SEAL, GREASE	1
26	730095	HUB COMPLETE (INCL. ITEMS 18 THRU 25)	1
27	596620M	BOLT, CARRIAGE 1/2 X 1-1/2 IN.	4
28	17205	COULTER MAIN ARM	1
29	596743M	NUT, HEX HEAD 3/4 IN. NYLOCK	1
30	17208	WASHER, SPRING END	2
31	590123	COULTER SPRING	1
32	17210	SPRING LEVER	1
33	596742M	NUT, HEX HEAD 5/8 IN. TOP LOCK	1
34	590260	BOLT, HEX HEAD 5/8 X 2 GRADE 5, SPECIAL	1
35	596261M	WASHER FLAT 5/8 IN.	2
NS	17248L	OFFSET COULTER MOUNT LEFT	AR
NS	17248R	OFFSET COULTER MOUNT RIGHT	AR
NS	17244	COULTER MOUNT TOP PLATE (WHEN U-BOLTS WILL NOT WORK)	AR
NS	596477M	BOLT HEX HEAD 5/8" X 9" GR5	AR

# ILLUSTRATED PARTS LIST (CONT'D)

## Coulter Knife Assembly

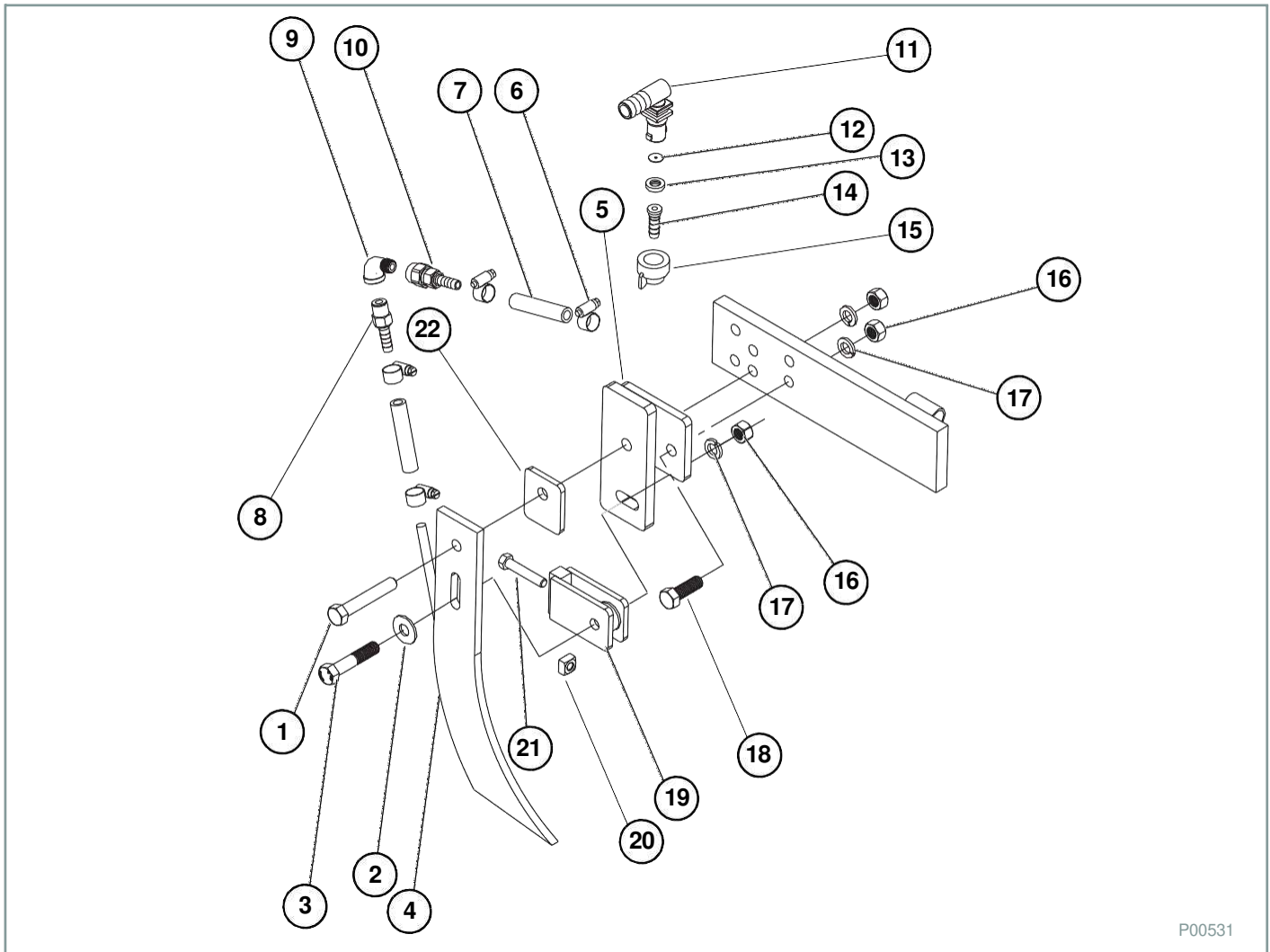

P00531

## ILLUSTRATED PARTS LIST (CONT'D)

### Coulter Knife Assembly (Cont'd)

ITEM NO.	PART NO.	DESCRIPTION	QTY.
1	CLFBH0813	CAP SCREW 1/2 IN. X 3-1/4 IN.	1
2	596260M	WASHER 1/2 IN. X 1-1/2 IN. X 0.105 IN.	2
3	596155M	BOLT HEX HEAD 1/2 IN. X 2-1/2 IN. GRADE 5	1
4	750003	COLTER KNIFE	1
5	17915	KNIFE MOUNT	1
6	540011	CLAMP 3/8 IN.	4
7	510020	BULK HOSE 3/8 IN., AG EPDM SPRAYER HOSE	AR
8	530247	HOSE BARB 1/4 IN. NPT X 3/8 IN. BARB	1
9	530246	ELBOW FITTING 1/4 IN., STREET, NPT SS	1
10	530188	CHECK VALVE HOSE SHANK CHECK VALVE ASSEMBLY	1
11	520003	ELBOW FITTING 3/4 IN., ELBOW-HOSE	AR
NS	520004	HOSE FITTING 3/4 IN., TEE HOSE BARB	AR
12*	TJCP4916-XXX	PLATE ORIFICE; REFER TO OM FOR ORIFICE SELECTION GUIDE	1
13	590029	SEALING WASHER ORIFICE DISC	1
14	590077	HOSE FITTING SHANK	1
15	590076	HOSE FITTING	1
16	C LFNH08	CAP HOSE SHANK	3
17	CLEWL08	LOCK WASHER 1/2 IN.	3
18	CLFBH0807	CAP SCREW 1/2 IN. X 1-3/4 IN.	1
19	17910	KNIFE ADJUSTER	1
20	596762M	NUT 3/8 IN. SQUARE NUT	1
21	596660M	CAP SCREW 3/8 IN. X 2 IN. FULL THREAD	1
22	17909	COULTER SHIM PLATE	1
NS	17920	KNIFE SHIM 14 GAUGE	AR
NS	17921	KNIFE SHIM 10 GAUGE	AR
NS	17922	KNIFE SHIM 7 GA+A1:H67UGE	AR

\* --THE XXX IS ORIFICE SIZE.

**ILLUSTRATED PARTS LIST (CONT'D)**

**Coulter Injection Assembly**

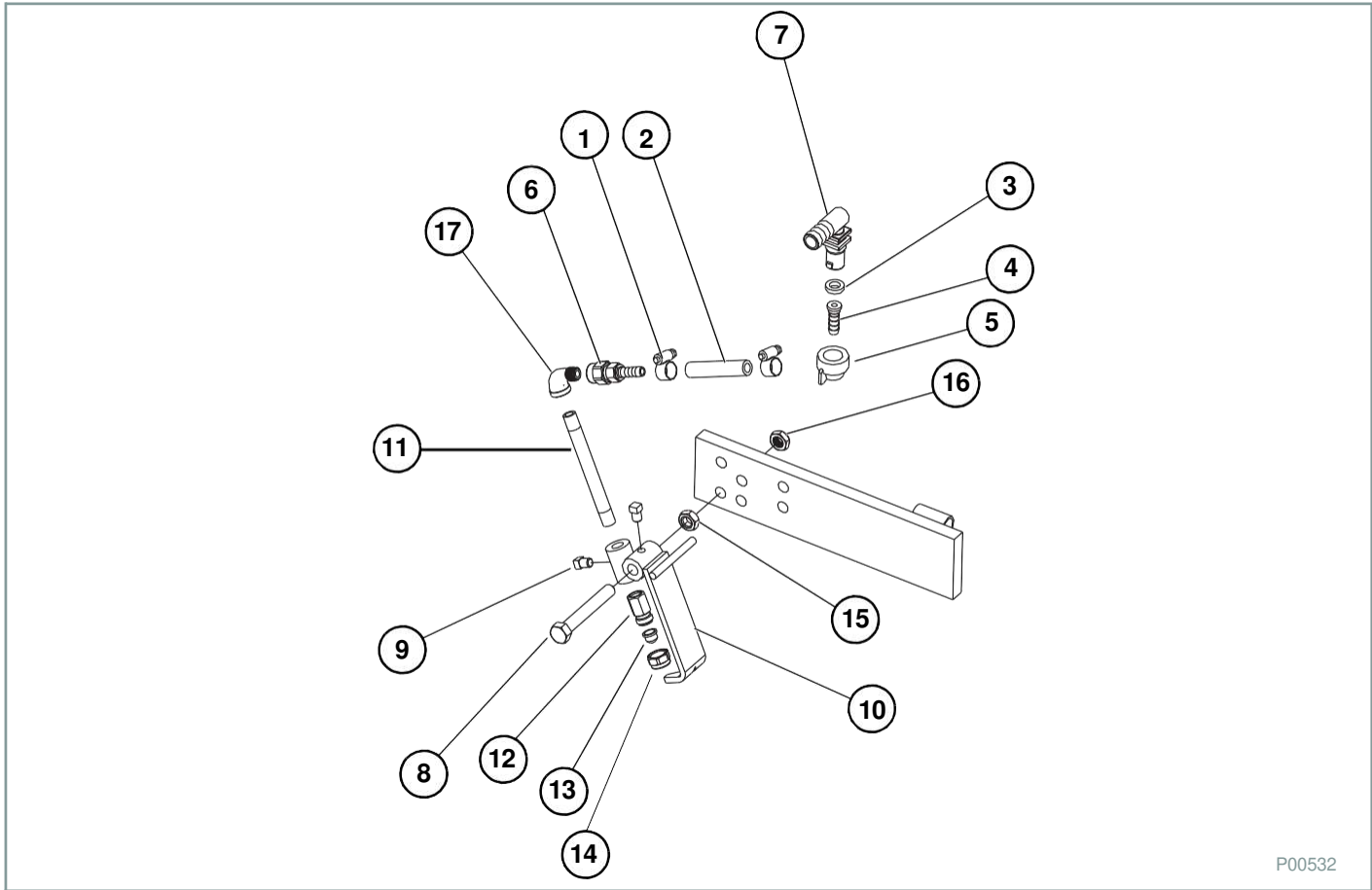

P00532

ITEM NO.	PART NO.	DESCRIPTION	QTY.
1	540032	CLAMP 5/16 IN.	4
2	510020	BULK HOSE 3/8 IN., AG EPDM SPRAYER HOSE	AR
3	590016	SEALING WASHER ORIFICE DISC	1
4	590077	HOSE FITTING SHANK	1
5	590076	CAP HOSE SHANK	1
6	530188	CHECK VALVE HOSE SHANK CHECK VALVE ASSEMBLY	1
7	520003	ELBOW FITTING 3/4 IN., ELBOW-HOSE	AR
NS	520004	ELBOW FITTING 3/4" TEE	AR
8	CLFBH0816SS	CAP SCREW 1/2 IN. X 4 IN., SS	1
9	CLFBS0602	SET SCREW 3/8 IN. X 1/2 IN.	2
10	750016	GUARD ROCK	1
11	530199	THREADED NIPPLE 1/4 X 5, SS	1
12	520014	NOZZLE HOLDER SS	1
13	TJTP00XX	NOZZLE TIP SS - #4; SEE OM FOR TIP SELECTION GUIDELINES	1
14	520015	CAP NOZZLE HOLDER	1
15	750009	NUT 1/2 IN. JAM, SS	1
16	750011	NUT 1/2 IN. NYLOCK, SS	1
17	530246	ELBOW FITTING 1/4 IN., STREET, NPT SS	1





ILLUSTRATED PARTS LIST (CONT'D)

1800 - 2400 Tank Assemblies

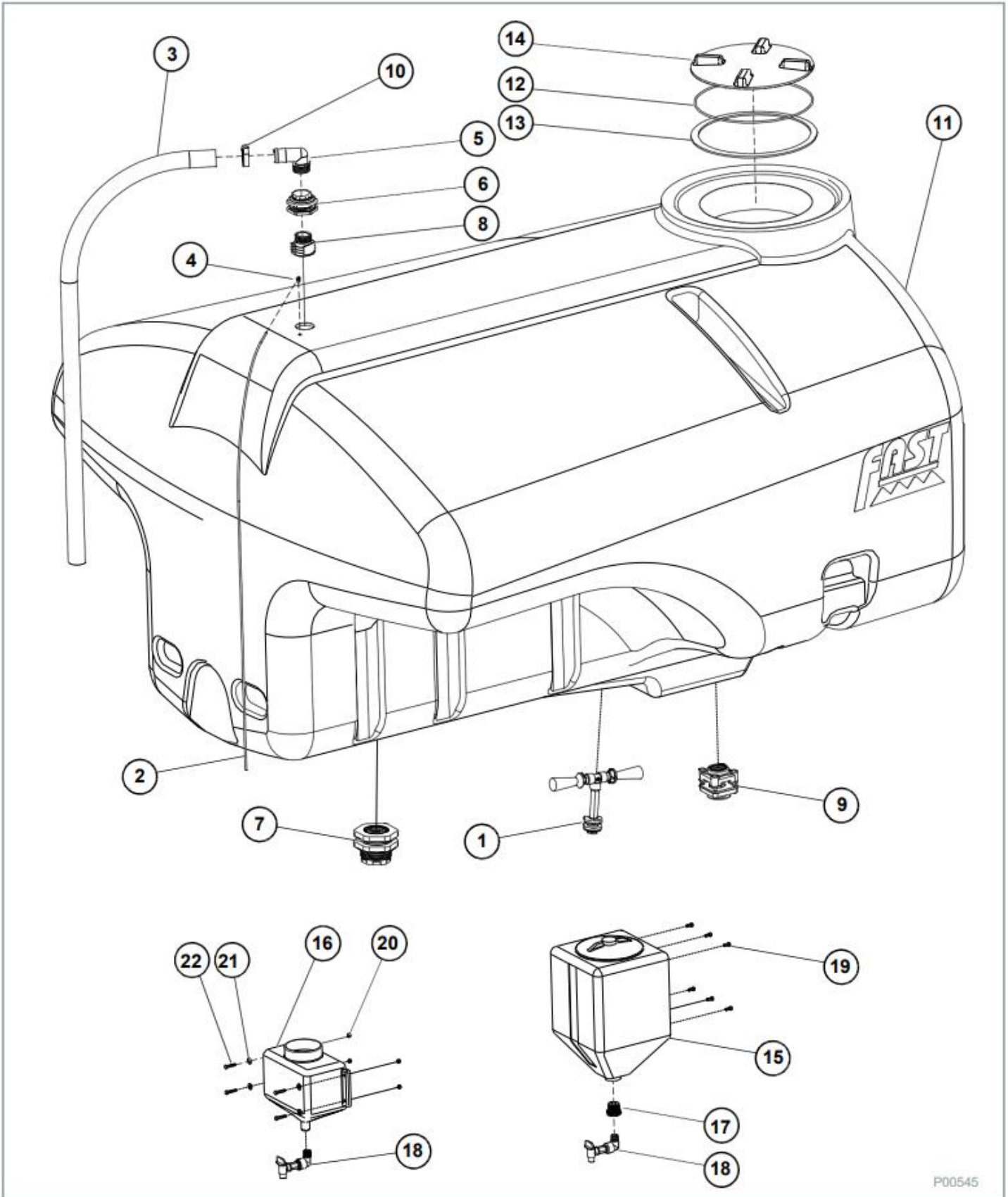

## ILLUSTRATED PARTS LIST (CONT'D)

### 1800 - 2400 Tank Assemblies (Cont'd)

ITEM NO.	PART NO.	DESCRIPTION	QTY.
1	90SALTRUMPET	AGITATION ASSEMBLY	1
2	510023	TUBE, PUMP BURP, 1/4 IN. X 18'	1
3	510025	HOSE, OVERFLOW, 2 IN. X 7'	1
4	530004	CONNECTOR, 90° 1/4 IN. TUBE X 1/4 IN. NPT	1
5	530051	2 IN. MPT X 2 IN. HOSE BARB 90°	1
6	530163	2 IN. TANK FITTING	1
7	530164	3 IN. TANK FITTING	1
8	530331	2 IN. VENTED CAP (10 GAL. TANK ONLY)	1
9	530350	2 IN. FLANGE BOTTOM DRAIN	1
10	540007	HOSE CLAMP, 2 IN. T-BOLT	1
11	570090	TANK, 2400 GALLON WHITE	1
	570091	TANK, 2400 GALLON YELLOW	
12-14	570158	LID ASSEMBLY, NON-VENTED	1
12	570120	O-RING	-
13	570121	FLAT GASKET	-
14	570123	NON VENTED TANK LID	-
15	570092	TANK 10 GAL, WHITE	1
	570097	TANK 10 GAL, YELLOW	
16	570038	HAND WASH TANK, 2.5 GAL, YELLOW (PRIOR TO 2015)	1
	570044	HAND WASH TANK, 2.5 GAL, WHITE (PRIOR TO 2015)	
17	530143	1-1/4 IN.MPTX3/4 IN.FPT REDUCE	1
18	90SAFCHWF	FC HAND WASH FAUCET ASSY	1
19	596114M	BOLT, HH 5/16-18X3/4 GR5 MAGNI (10 GAL. TANK ONLY)	6
20	596228M	NUT, HEX NYLOCK 5/16-18 MAGNI (PRIOR TO 2015)	4
21	596257M	WASHER, FLAT 5/16 USS MAGNI (PRIOR TO 2015)	4
22	596116M	BOLT, HH 5/16-18X1-1/2 GR5 MAGNI (PRIOR TO 2015)	4

**ILLUSTRATED PARTS LIST (CONT'D)**

**Three Inch Quick Fill**

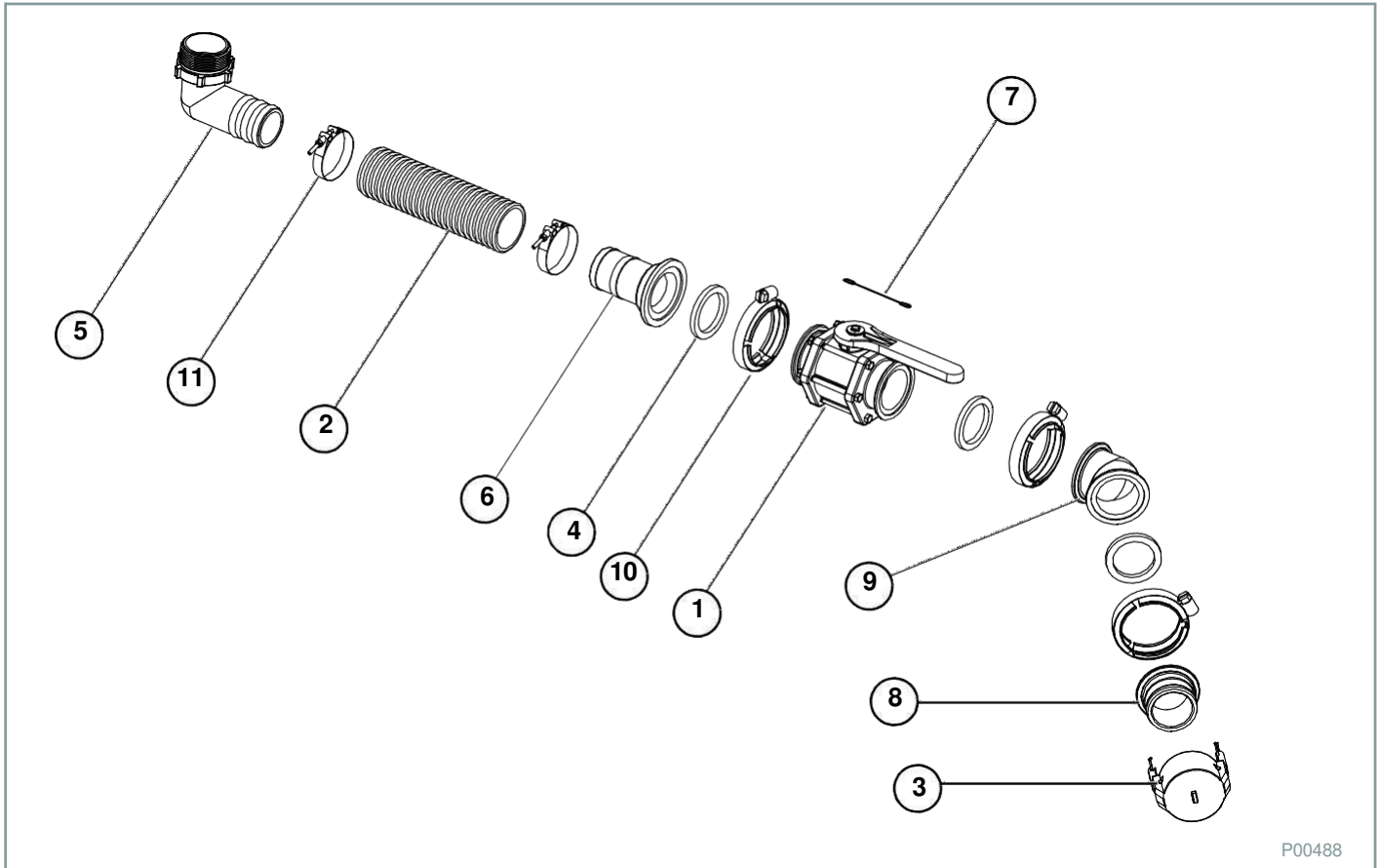

P00488

ITEM NO.	PART NO.	DESCRIPTION	QTY.
1	500042	VALVE, 3" MANIFOLD	1
2	510038	HOSE, 3" FERTILIZER	1
3	530023	CAP, 3"	1
4	530024	GASKET, 3" EPDM	3
5	530053	3" HOSE BARB ELBOW 90°	1
6	530113	3" MANIFOLD X 3" HOSE BARB	1
7	530179	LANYARD	1
8	530233	3" MANIFOLD X 3" MALE ADAPTER	1
9	530234	3" MANIFOLD COUPLER, 45°	1
10	540003	CLAMP, 3"	3
11	540009	CLAMP, 3" T BOLT	2



ILLUSTRATED PARTS LIST (CONT'D)

Tank To Pump Plumbing

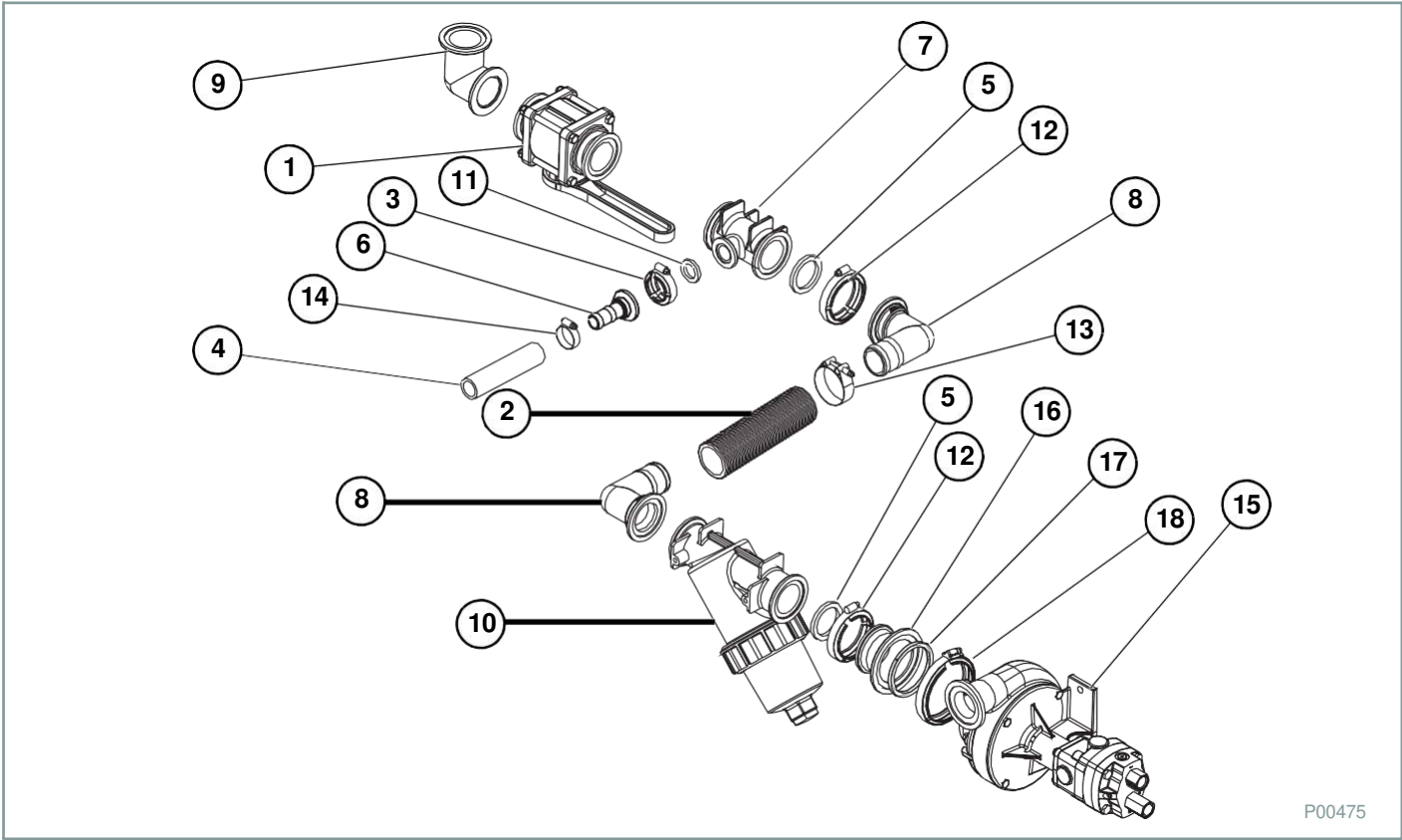

## ILLUSTRATED PARTS LIST (CONT'D)

### Tank To Pump Plumbing (Cont'd)

ITEM NO.	PART NO.	DESCRIPTION	QTY.
1	500006	VALVE FLANGED 2 IN. FP-4 BOLT	1
2	510003	HOSE 2 IN FERTILIZER	AR
3	540000	MANIFOLD CLAMP 1 IN.	1
4	510016	HOSE 1 IN EPDM	AR
5	530019	2 IN. EPDM GASKET	6
6	530066	1 IN. MANIFOLD X 1 IN. BARB	1
7	530099	2 IN. FULL PORT X 1 IN. FLANGE	1
8	530104	2 IN. FP FLANGE X 2 IN. HB 90	2
9	530106	2 IN.FP X 2 IN. FP MANIFOLD CO	1
10	530125	STAINER MANIFOLD FULL PORT	1
11	530013	1 IN.EPDM GASKET FOR 1 IN. & 1	1
12	540002	CLAMP 2 IN. FULL WORM SCREW	6
13	540008	CLAMP 2 IN. T-BOLT HOSE 2.87 MI	2
14	540014	CLAMP 1 IN. WORM SCREW	1
15	550025	PUMP ACE	1
	550011	PUMP HYPRO (OPTIONAL)	
16	530316	FLANGE REDUCER	1
17	530024	3 IN. EDPM GASKET	1
18	540003	MANIFOLD CLAMP 3 IN.	1
ITEMS 16-18 NOT USED WITH HYPRO PUMP (OPTIONAL) ITEM 15			

ILLUSTRATED PARTS LIST (CONT'D)

Large Cart To Ball Valve Plumbing

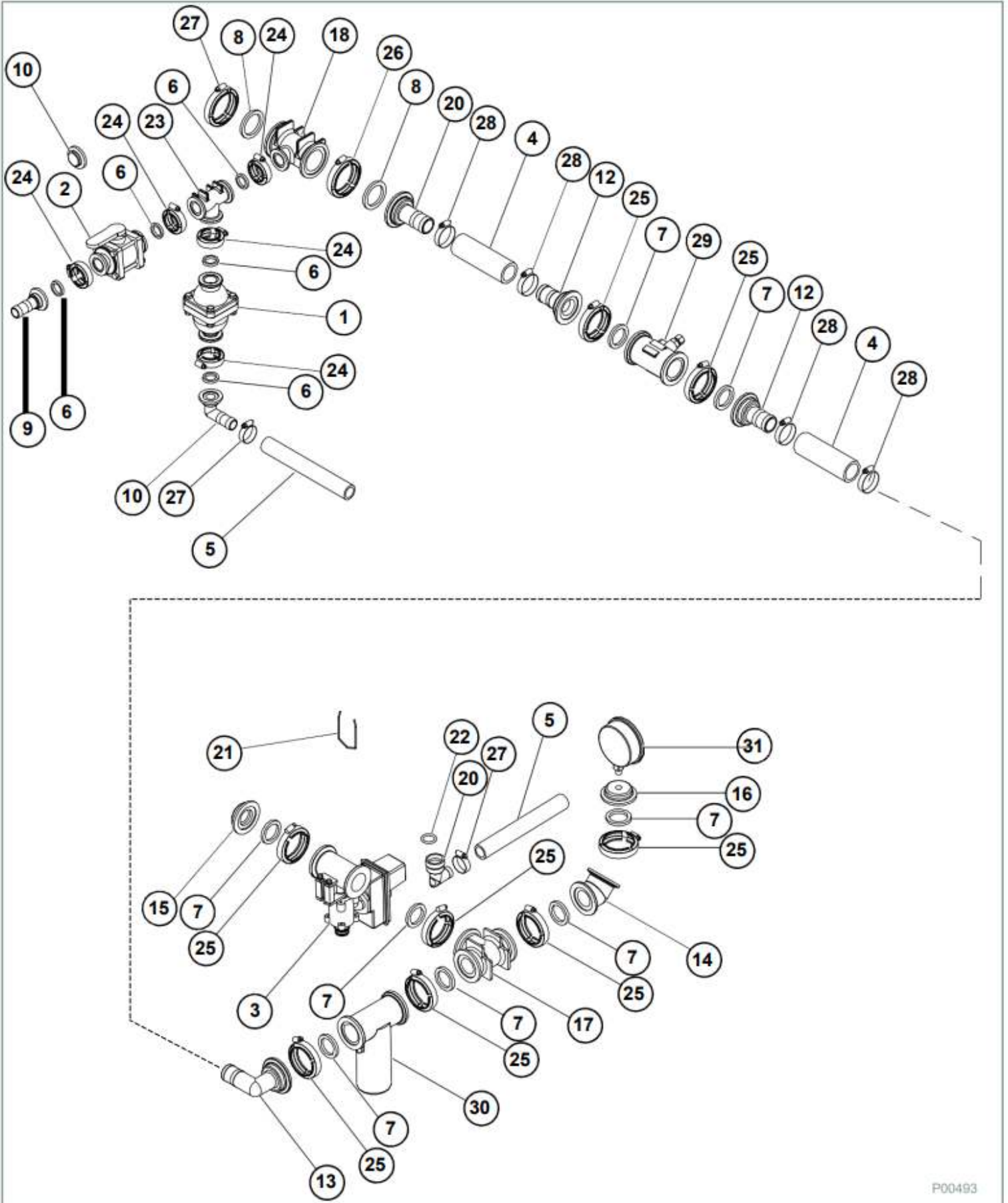

P00493



**ILLUSTRATED PARTS LIST (CONT'D)**
**Large Cart To Ball Valve Plumbing (Cont'd)**

ITEM NO.	PART NO.	DESCRIPTION	QTY.
1	500004	VALVE, 100 PSI RELIEF	1
2	500005	VALVE, 1" FULL PORT	AR
2	500027	VALVE 450BEC MANIFOLD (NARROW) (NON-FLOWBACK)	AR
3	500028	VALVE 450BEC MANIFOLD (WIDE) (NON-FLOWBACK)	AR
4	510014	HOSE, 1-1/2" EPDM	AR
5	510016	HOSE, 1" EPDM	AR
6	530013	GASKET, 1" EPDM	AR
7	530014	GASKET, 1-1/2" EPDM	AR
8	530019	GASKET, 2" EPDM FULL PORT	AR
9	530066	1" MANIFOLD X 1" HOSE BARB	AR
10	530063	1" MANIFOLD X 1" HB 90°	1
11	530070	1" MANIFOLD PLUG (WITHOUT AGITATION)	AR
12	530079	2" MANIFOLD X 1-1/2" HOSE BARB	AR
13	530080	2" MANIFOLD X 1-1/2" HOSE BARB 90°	1
14	530087	2" FLANGE COUPLER, 45°	AR
15	530093	2" MANIFOLD PLUG	1
16	530094	2" MANIFOLD PLUG W/ 1/4" FPT	1
17	530097	2" MANIFOLD TEE	1
18	530099	2' FULL PORT MANIFOLD X 1" FLANGE TEE	AR
19	530100	2" FULL PORT X 1-1/2" HOSE BARB	AR
20	530190	1" 90° HOSE BARB, NYLON	AR
21	530193	RETAINING CLIP	AR
22	530198	O-RING, VITON®	AR
23	530298	1" MANIFOLD TEE	1
24	540000	CLAMP, 1"	AR
25	540001	CLAMP, 2"	AR
26	540002	CLAMP, 2" FULL PORT	AR
27	540014	CLAMP, 1"	AR
28	540016	CLAMP, 1-1/2"	4
29	631804	FLOW METER, 60P	AR
29	631801	FLOW METER, 100P	AR
30	631805	CONTROL VALVE, 1-1/2"	1
31	790020	GAUGE, 160 PSI	1

# ILLUSTRATED PARTS LIST (CONT'D)

## Toolbar Plumbing

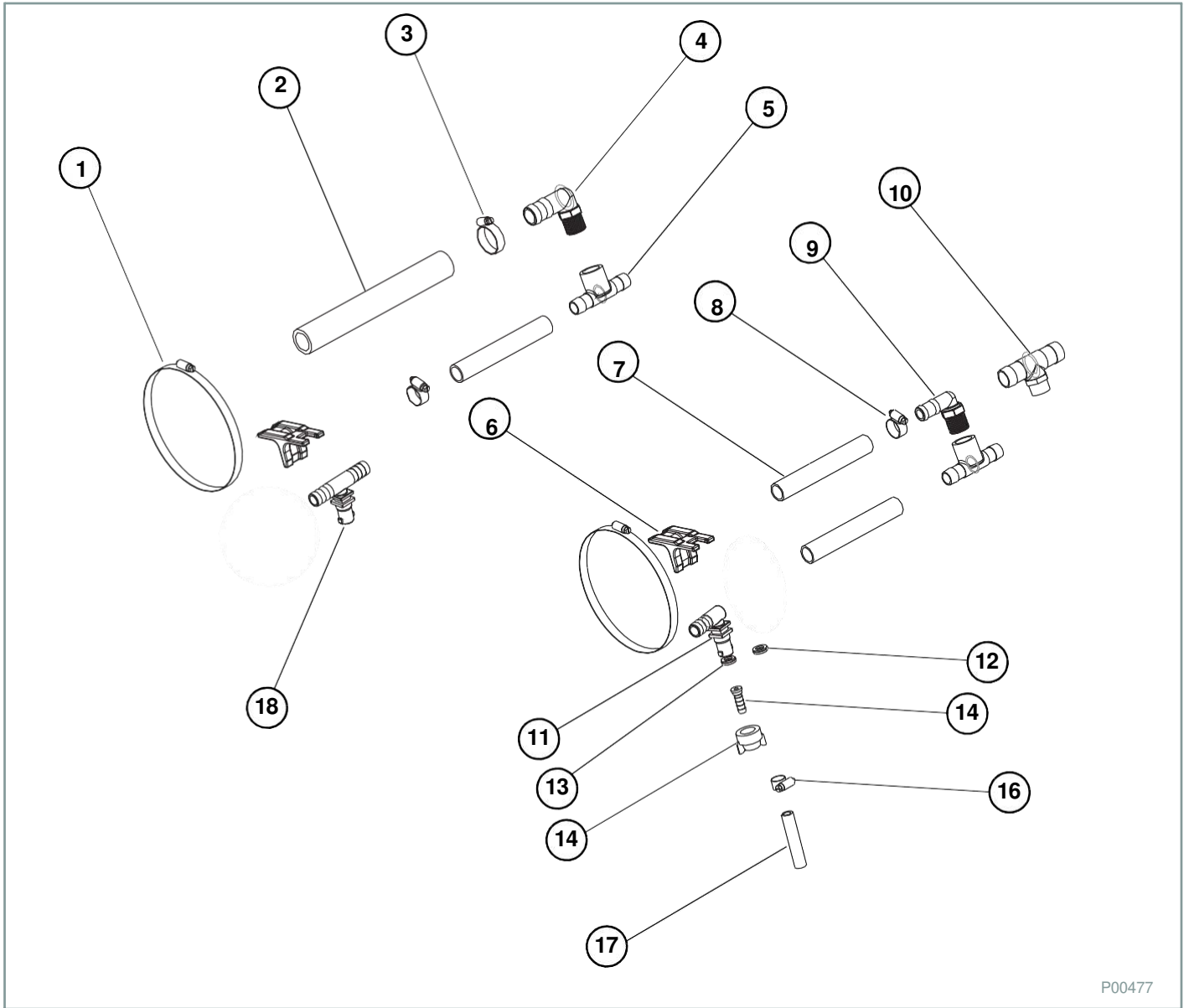

P00477

## ILLUSTRATED PARTS LIST (CONT'D)

### Toolbar Plumbing (Cont'd)

ITEM NO.	PART NO.	DESCRIPTION	QTY.
1	540050	HOSE CLAMP 7 IN.	AR
2	510016	HOSE 1 IN. EDPM	AR
3	540014	HOSE CLAMP 1 IN.	AR
4	530036	HOSE BARB 90° 3/4 IN. PT X 1 IN. HB	AR
5	530220	TEE 3/4 IN. HOSE BARB X 3/4 IN. FPT	AR
6	590187	MOUNT NOZZLE BODY	AR
7	510019	HOSE 3/4 IN. EDPM	AR
8	540013	HOSE CLAMP 3/4 IN.	AR
9	510011	HOSE BARB 90° 3/4 IN. PT X 3/4 IN. HB	AR
10	530230	3/4 IN. MPT X 3/4 IN. HOSE BARB TEE	AR
11	530221	NOZZLE SINGLE	AR
12**	520016	GASKET FOR INJECTION	AR
13*	590029	GASKET (ORFICE) FOR KNIFE	AR
14*	590076	CAP FOR BARB	AR
15	590077	CONNECTOR, HOSE BARB	AR
16	540011	HOSE CLAMP 3/8 IN.	AR
17	510020	HOSE 3/8 IN. EDPM	AR
18	520004	NOZZLE TEE FOR INJECTION	AR
* - ITEM 13 USED WITH KNIFE ON COULTER			
** - ITEMS 12 USED WITH INJECTION ON COULTER			

**ILLUSTRATED PARTS LIST (CONT'D)**

**Agitation And Control 90SALTRUMPET**

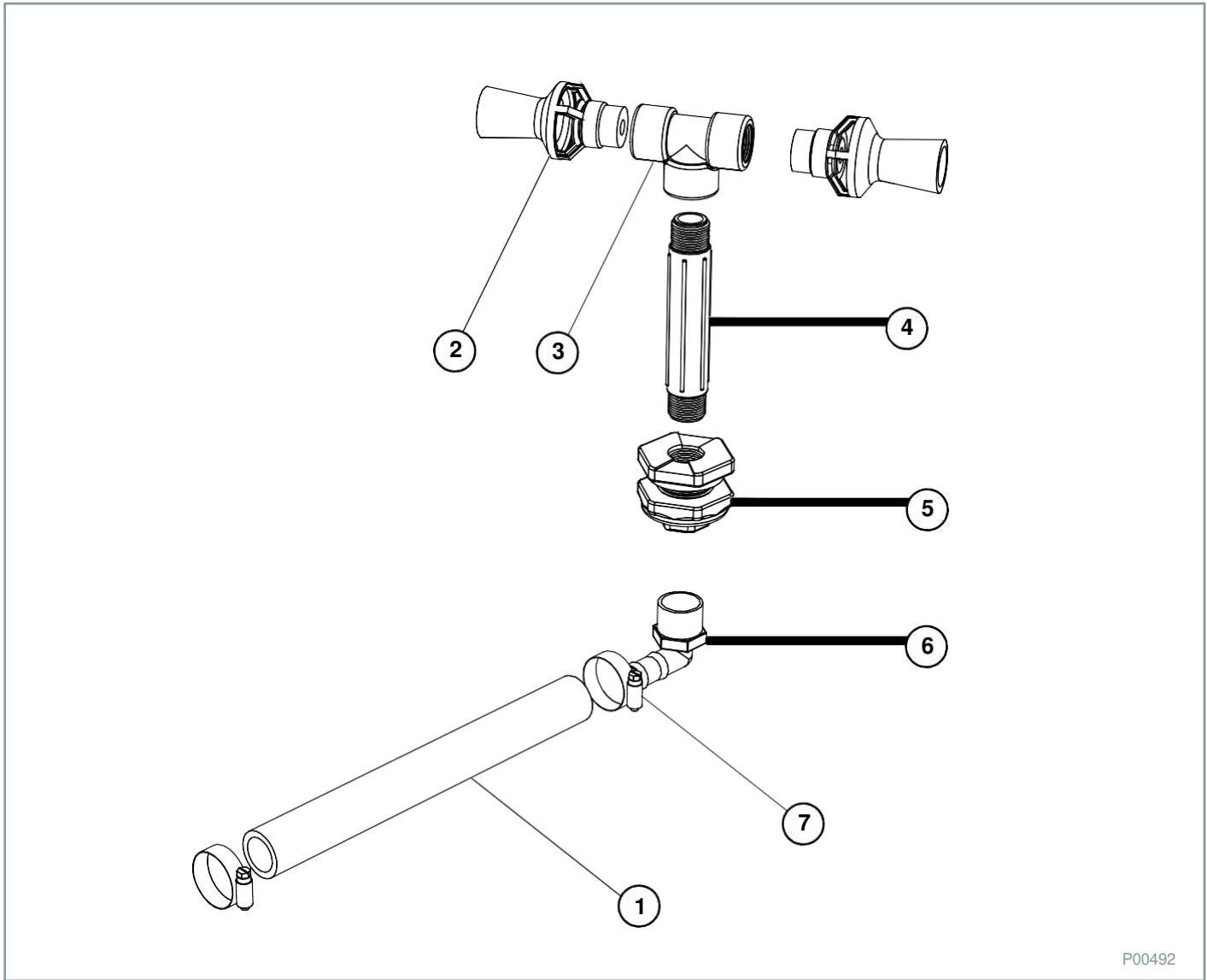

P00492

ITEM NO.	PART NO.	DESCRIPTION	QTY.
1	510016	HOSE 1 IN. EDPM	AR
2	520029	AGITATION NOZZLE	2
3	530156	TEE 3/4 IN. NPT	1
4	530130	NIPPLE 3/4 IN. X 6	1
5	530160	BULKHEAD 3/4 IN. NPT	1
6	530036	HOSE BARB ELBOW 3/4 IN. NPT X 1 IN. HOSE	1
7	540014	CLAMP 1 IN. HOSE	2



ILLUSTRATED PARTS LIST (CONT'D)

Ace 205F - 304 Pump

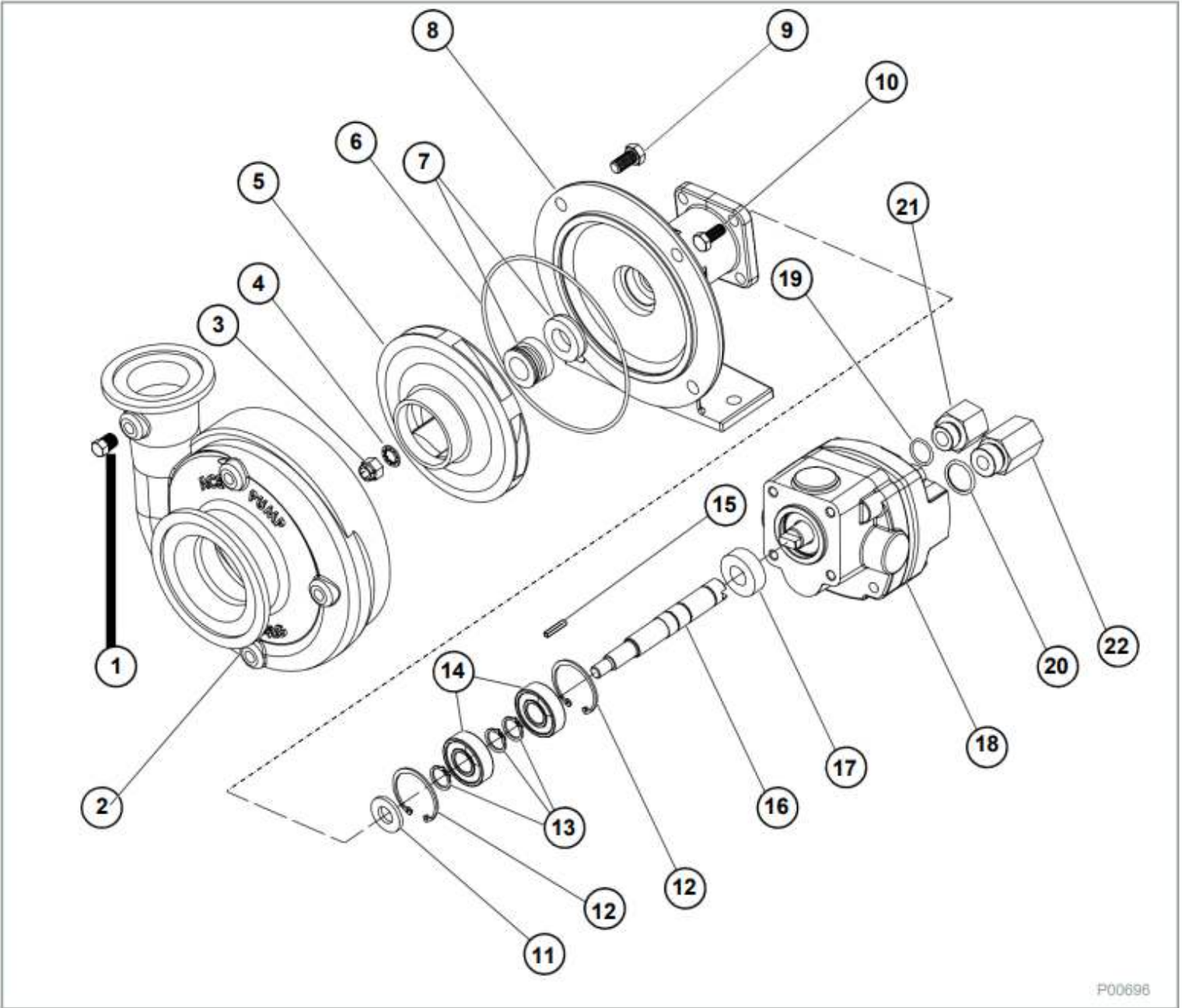

P00696

## ILLUSTRATED PARTS LIST (CONT'D)

Ace 205F - 304 Pump 550025 (Cont'd)

ITEM NO.	PART NO.	DESCRIPTION	QTY.
1	41100	PIPE PLUG	4
2	41530	VOLUTE, 300 STANDARD FLANGE X 220 FULL PORT FLANGE, CAST IRON	1
3	43092	NUT, 3/8" NF, STAINLESS STEEL	1
4	4044	WASHER, 3/8", STAINLESS STEEL, SELF-LOCKING	1
5	40434	IMPELLER, THERMOPLASTIC	1
6*	40005	O-RING, BODY SEAL	1
7*	40149	SEAL, SILICON CARBIDE	1
8	40338	MOUNTING FRAME FOR 205 PUMP	1
9	40950	CAP SCREW, 3/8" NC X 3/4" HEX HEAD	4
10	41330	CAP SCREW, 5/16" NC X 3/4" HEX HEAD, MOTOR TO PUMP	4
11	41130	SLINGER	1
12	40820	SNAP RING, INTERNAL, BAC-14-205 MOUNTING FRAME	2
13	40835	SNAP RING, EXTERNAL, BAC-6-205 SHAFT	3
14	40880	BALL BEARING, SEALED, BAC-6-205 SHAFT	2
15	40068	SHAFT, EXTENDED KEYWAY, TANG, STAINLESS STEEL	1
16	40425	KEY, 1/8" X 1/8" X 13/16", EXTENDED KEYWAY	1
17	40163	SEAL SUPPORT SPACER FOR 205 SERIES PUMP	1
18	41426	HYDRAULIC MOTOR, 11 GPM, EFFECTIVE 5/13	1
19	41875	O-RING, #8 SAE FITTING	1
20	41445	O-RING, #10 SAE FITTING	1
21	41461	BODY, RESTRICTOR ORIFICE, #8 SAE X #10 SAE	1
22	41467	REVERSE CHECK ASSEMBLY, #10 SAE X #10 SAE	1
NS	52705	REPAIR KIT FOR FMC-205 PUMP WITH SILICON CARBIDE SHAFTSEAL (INCLUDES ITEMS 6 AND 7)	AR
NS	41361	REPAIR KIT FOR 300 SERIES HYDRAULIC MOTOR	AR

ILLUSTRATED PARTS LIST (CONT'D)

Hypro Pump

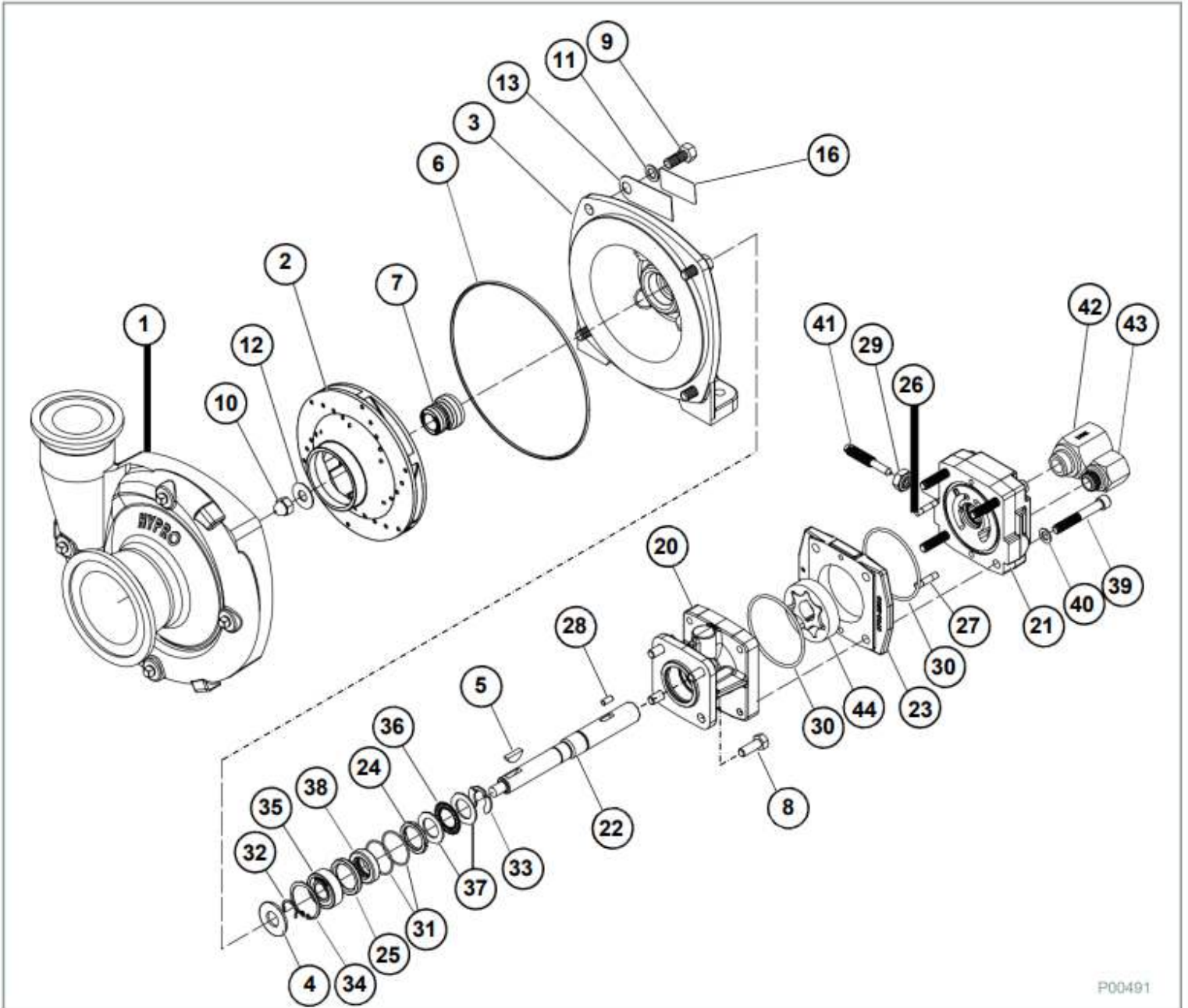

P00491

550011 Complete pump  
HY-93079  
9306C-HM1C-UB



## ILLUSTRATED PARTS LIST (CONT'D)

### Hypro Pump (Cont'd)

ITEM NO.	PART NO.	DESCRIPTION	QTY.
1	0157-9200C	PUMP HOUSING, 300X220 U.FLG	1
2	0401-9200P2	IMPELLER (CW ROTATION)	1
3	0750-9300C2	MOUNTING FLANGE	1
4	1410-0056	SLINGER SEAL	1
5	1610-0012	WOODRUFF KEY	1
6	1720-0083	O-RING	1
7	2120-0039	SEAL, MECHANICAL	1
8	2210-0005	CAP SCREW, HEX HEAD 5/16 IN. -18 X 7/8 IN.	1
9	2210-0020	CAP SCREW, HEX HEAD 3/8 IN. -16 X 7/8 IN.	4
10	2253-0002	ALCNUT 0.3750-24-N	4
11	2270-0041	WASHER	1
12	2270-0071	IMPELLER WASHER	1
13	2270-0076	TAG	1
16	6031-0325	DECAL	1
20	0150-2500C	BODY ASSY-SMALL PILOT	1
21	0254-2500C2	END PLATE ASSY	1
22	0533-2500	SHAFT	1
23	0700-2500C1	GEROTOR HOUSING HM1, COATED	1
24	1410-0130	SPACER, 3L SEAL	1
25	1410-0131	CARTRIDGE, FRONT	1
26	1600-0037	DOWEL PIN	1
27	1600-0044	DOWEL PIN	1
28	1610-0031	HM1 & HM5 ROUND KEY	1
29	1700-0245	NUT, SEALING	1
30	1720-0110	O-RING	2
31	1720-0268	O-RING	2
32	1810-0014	RETAINING RING	1
33	1810-0026	RETAINING RING	1
34	1820-0013	INT. RET. RING	1
35	2000-0010	BEARING, BALL	1
36	2029-0009	BEARING, THRUST	1
37	2029-0010	BEARING RACE, THRU	2
38	2104-0010	LIP SEAL	1
39	2220-0021	SCREW, SOCKET HEAD	4
40	2270-0039	WASHER, FLAT 5/16 IN.	4
41	3220-0029	VALVE STEM	1
42	3320-0052A	CHECK VALVE ASSY - TANK PORT	1
43	3360-0023A	ADAPTER-INLET PORT ASSY	1
44	3900-0022	GEROTOR	1

ILLUSTRATED PARTS LIST (CONT'D)

Directo Valve® Electric 2-Way Ball Valve Manifold

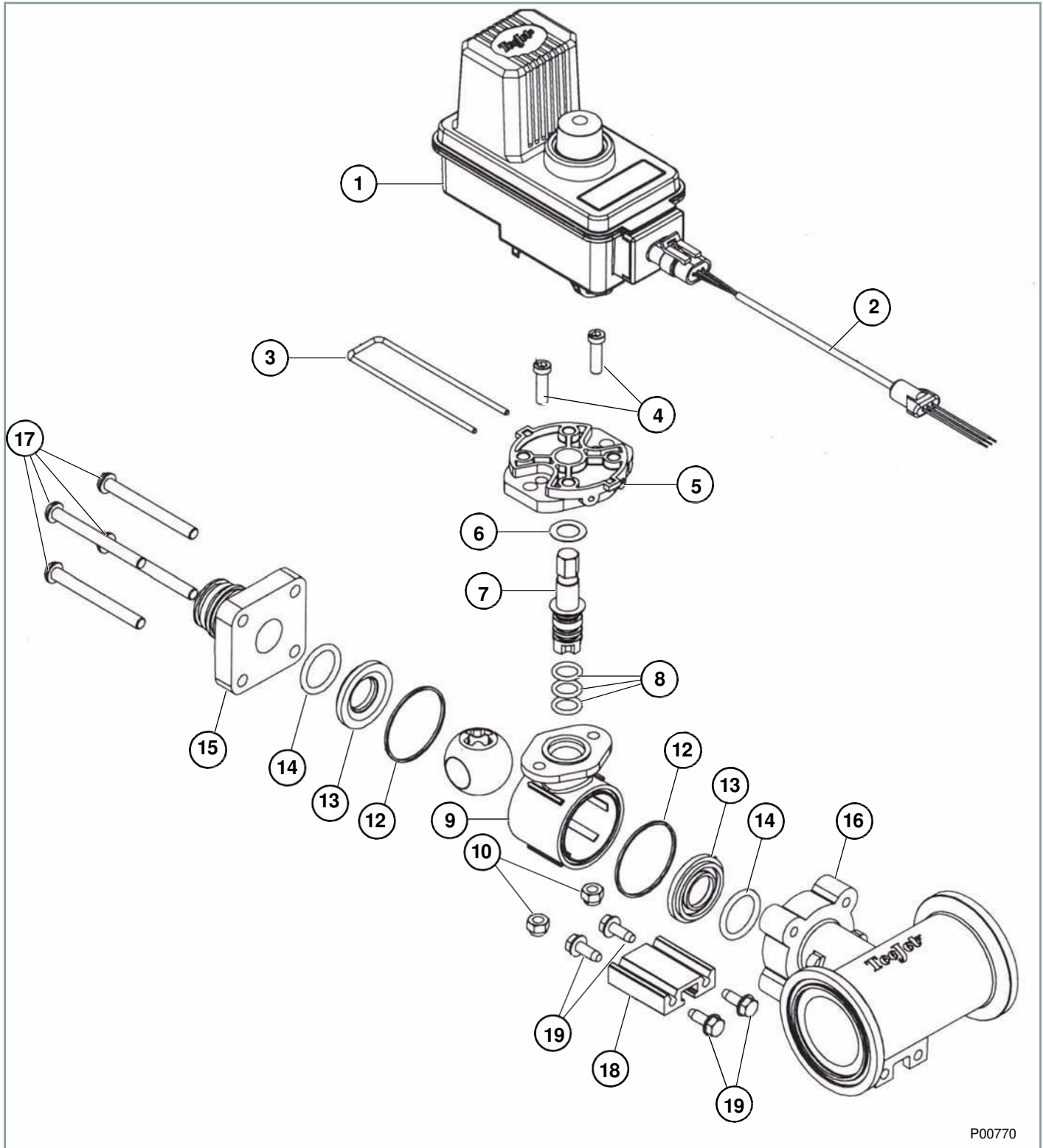

P00770

## ILLUSTRATED PARTS LIST (CONT'D)

### FAST Coulter Assembly (Cont'd)

ITEM NO.	PART NO.	DESCRIPTION	QTY.
1	50515-22CP03	BEC MOTOR, 22-RPM (0.7-SEC),0.3-METER CABLE, POSITIVELY SWITCHED	1
2	98546EC-_	3-WIRE CABLE W/ METRI-PACK TOWER CONNECTION	1
3	CP50517-SSPV	RETAINING CLIP, 304 STAINLESS STEEL	1
4	CP26197-7/8-SS	SOCKET HEAD CAP SCREW, STAINLESS STEEL	2
5	CP5514-99	MOTOR ADAPTER, POLYPROPYLENE (BLACK)	1
6	CP20125-TEF	THRUST WASHER, TEFLON™	1
7	CP56613-SS	STEM, 303 STAINLESS STEEL (FOR POLYPYLENE BALL	1
8	CP7717-M12X2.5-VI	O-RING VITON®	3
9	CP20101-NYB	BODY, NYLON (BLACK) (2-WAY)	1
10	CP38435-1/4-SSNY	ELESTIC LOCKNUT, STAINLESS STEEL	2
11	CP20106-1-PP	BALL, POLYPROPYLENE (WHITE) (2-WAY)	1
12	CP20564-VI	GASKET, VITON®	2
13	CP20103-TEF	SEAL, TEFLON™	2
14	CP7717-2/213-VE	O-RING, VITON™	2
15	CP45514-NYB	END CAP, NYLON (BLACK) (QUICK CONNECT)	1
16	CP45251-PP	75-SERIES TEE BODY, POLYPYLENE (BLACK)	1
17	CP45252-2-3/4-SSPV	SCREW, 1/4 IN.-12 X 2-3/4 IN. PAN HEAD, STAINLESS STEEL	4
18	CP45216-AL	MOUNTING RAIL, ALUMINUM	1
19	CP45259-S	SCREW, M6 X 1 16 MM HEX, STAINLESS STEEL	1
NS	56609-2 _ _ _ _	VALVE BODY SUB-ASSY, SPECIFY WIDTH, OUTLET FITTING AND BALL MATERIAL (INCLUDES ITEMS 4 THROUGH 19)	1
NS	AB344AE-KIT	SPARE PARTS KIT (INCLUDES ITEMS 6, 8, 12, 13 AND 14)	1

**ILLUSTRATED PARTS LIST (CONT'D)**

**1-1/2 In. Poly Control Valve Assembly (063-0171-894)**

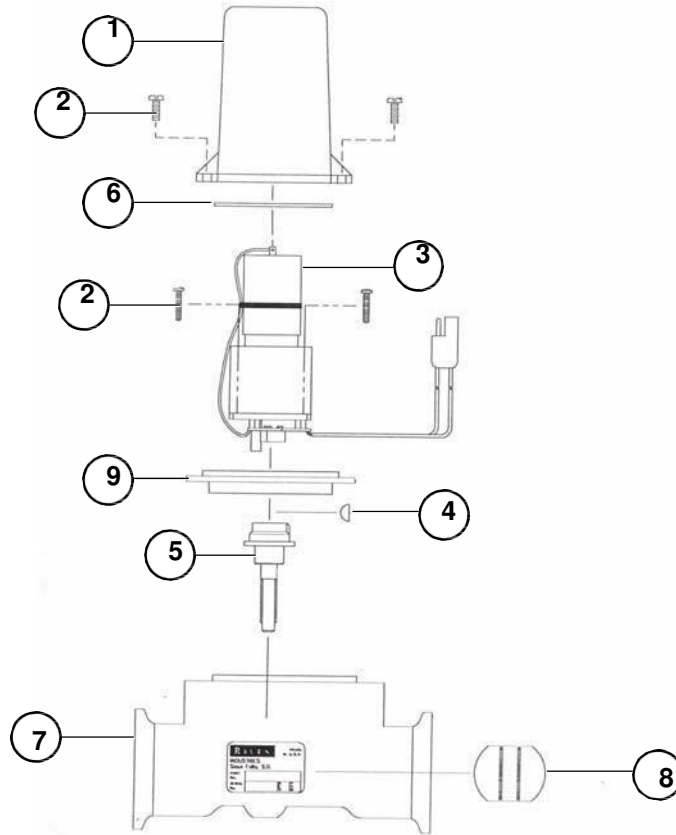

P00769

ITEM NO.	PART NO.	DESCRIPTION	QTY.
1	106-0159-407	VALVE COVER	1
2	321-0000-256	#6-32X3/4" LG.SCREW	4
3	063-0159-409	MOTOR ASSEMBLY	1
4	321-0000-063	WOODRUFF KEY	1
5	063-0171-893	COUPLER SHAFT ASSEMBLY (1-1/2 IN. VALVE)	1
6	219-0000-020	SEAL TETRASEAL	1
7	063-0171-892	VALVE BODY ASSEMBLY (1-1/2 IN. VALVE)	1
8	106-0159-414	BUTTERFLY (1-1/2 IN. VALVE)	1
9	063-0159-457	ISOLATION FLANGE ASSEMBLY	1
NS	117-0159-739	ISO BODY KIT (1-1/2 IN. VALVE)	1
NS	115-0159-415	POLARITY REVERSAL JUMPER	1
NS	222-1001-050	LOCTITE RC-609®	1

## ILLUSTRATED PARTS LIST (CONT'D)

Flowmeter, Raven, RFM100 P Assembly (063-0171-066) 631801

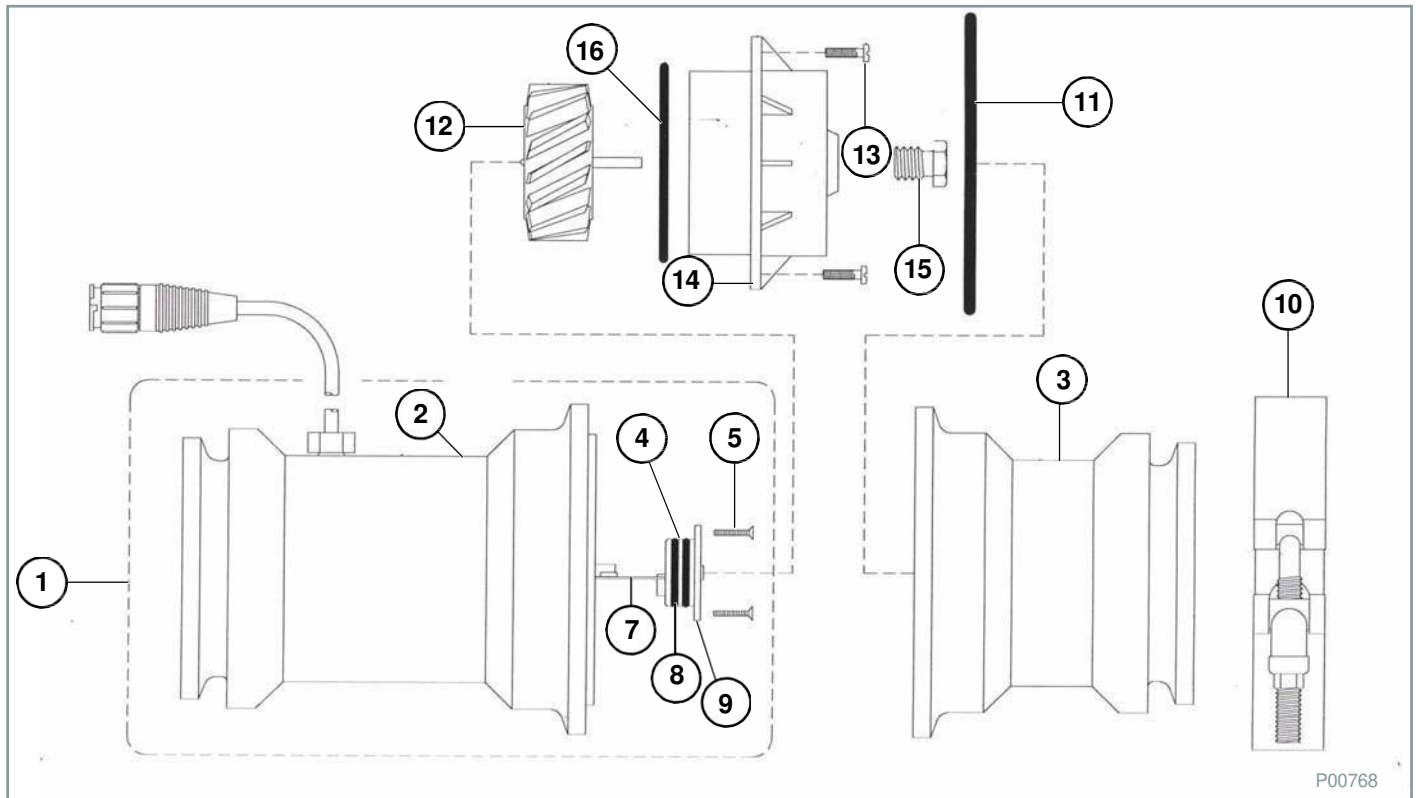

P00768

ITEM NO.	PART NO.	DESCRIPTION	QTY.
1	063-0171-068	OUTLET HOUSING ASSEMBLY	1
2	107-0171-006	OUTLET HOUSING	1
3	107-0171-005	HUB HOUSING, INLET	1
4	063-0171-069	END BEARING/P.C. ASSEMBLY	1
5	311-0013-390	2-56X1/5 IN. FLAT HD. S.S. SCREW	2
6	117-0159-567	END BEARING/P.C. ASSEMBLY KIT (CONTAINS ITEMS 4 AND 5)	1
7	064-0159-913	P.C. ASSEMBLY	1
8	219-0002-018	O-RING, VITRON	1
9	063-0171-067	END BEARING ASSEMBLY	1
10	435-3003-032	RETAINING CLAMP	1
11	219-0002-018	O-RING, VITRON	1
12	321-0000-221	RFM 100 TURBINE	1
13	310-0002-133	6-20X1/2" PAN HD. S.S. SCREW	1
14	321-0000-222	TURBINE HUB/BEARING ASSEMBLY	1
15	063-0171-082	TURBINE STUD ASSEMBLY	1
16	219-0002-140	O-RING, VITRON	1
NS	107-0159-509	MOUNTING BRACKET, RFM 100	1
NS	435-3003-009	HOSE CLAMP	1
NS	117-0159-441	CABLE KIT	1

**ILLUSTRATED PARTS LIST (CONT'D)**

**Flowmeter, Raven, RFM60 P Assembly (063-0171-793)**

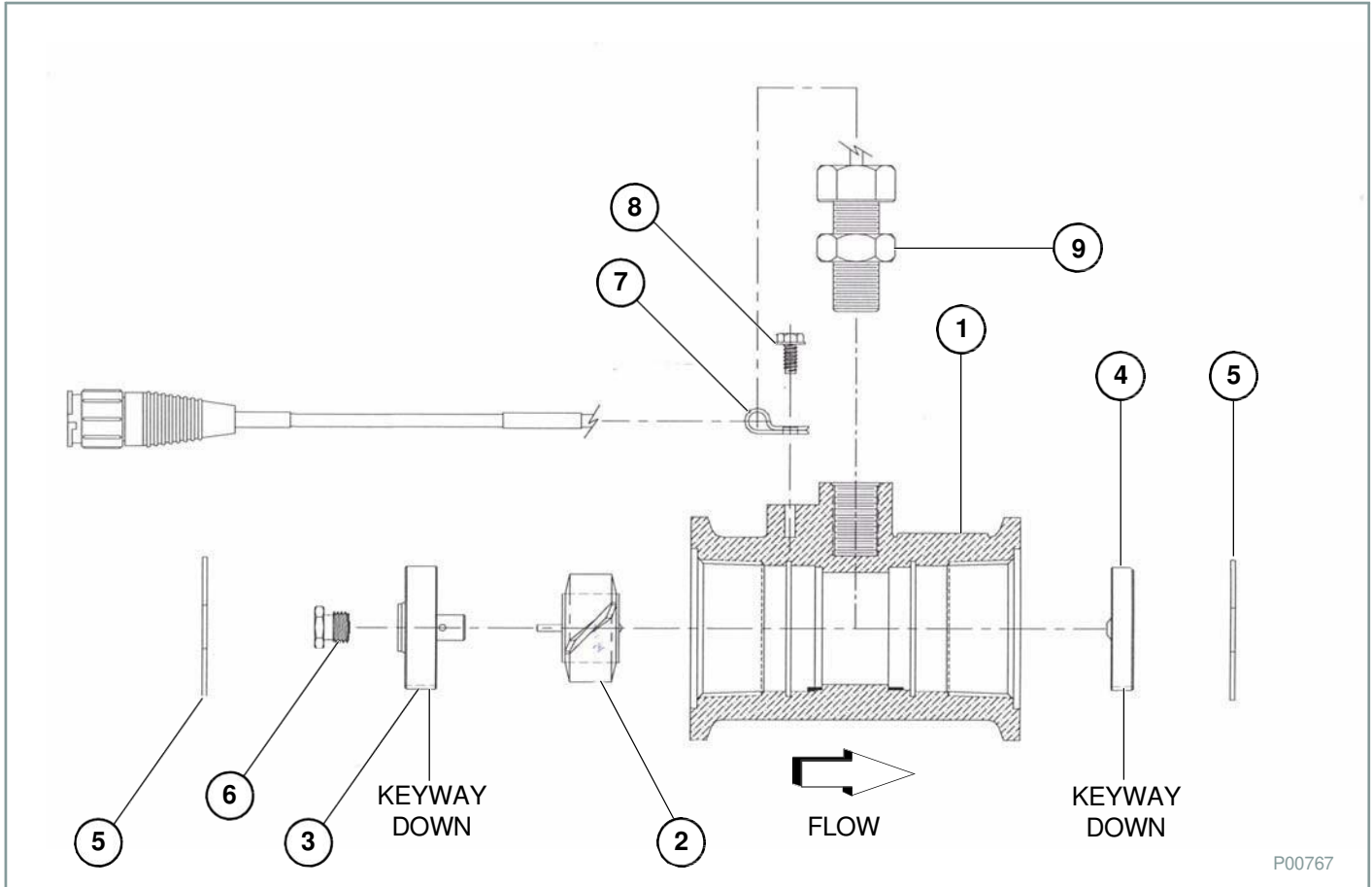

P00767

ITEM NO.	PART NO.	DESCRIPTION	QTY.
1	106-0159-514	BODY, RFM 60 P FLOWMETER	1
2	063-0171-673	ROTOR/MAGNET ASSEMBLY	1
3	063-0171-674	HUB/BEARING ASSY. UPSTREAM	1
4	063-0171-769	HUB ASSEMBLY, DOWNSTREAM	1
5	335-0000-278	RING, RETAINING, INTERNAL	1
6	063-0159-573	STUD BEARING	1
7	435-3002-017	CLAMP, CABLE	1
8	310-0002-137	SCREW, THREAD FORMING	1
9	063-0171-669	SENSO, ASSEMBLY, EXTERNAL	1



# ILLUSTRATED PARTS LIST (CONT'D)

## Raven SCS450 Console

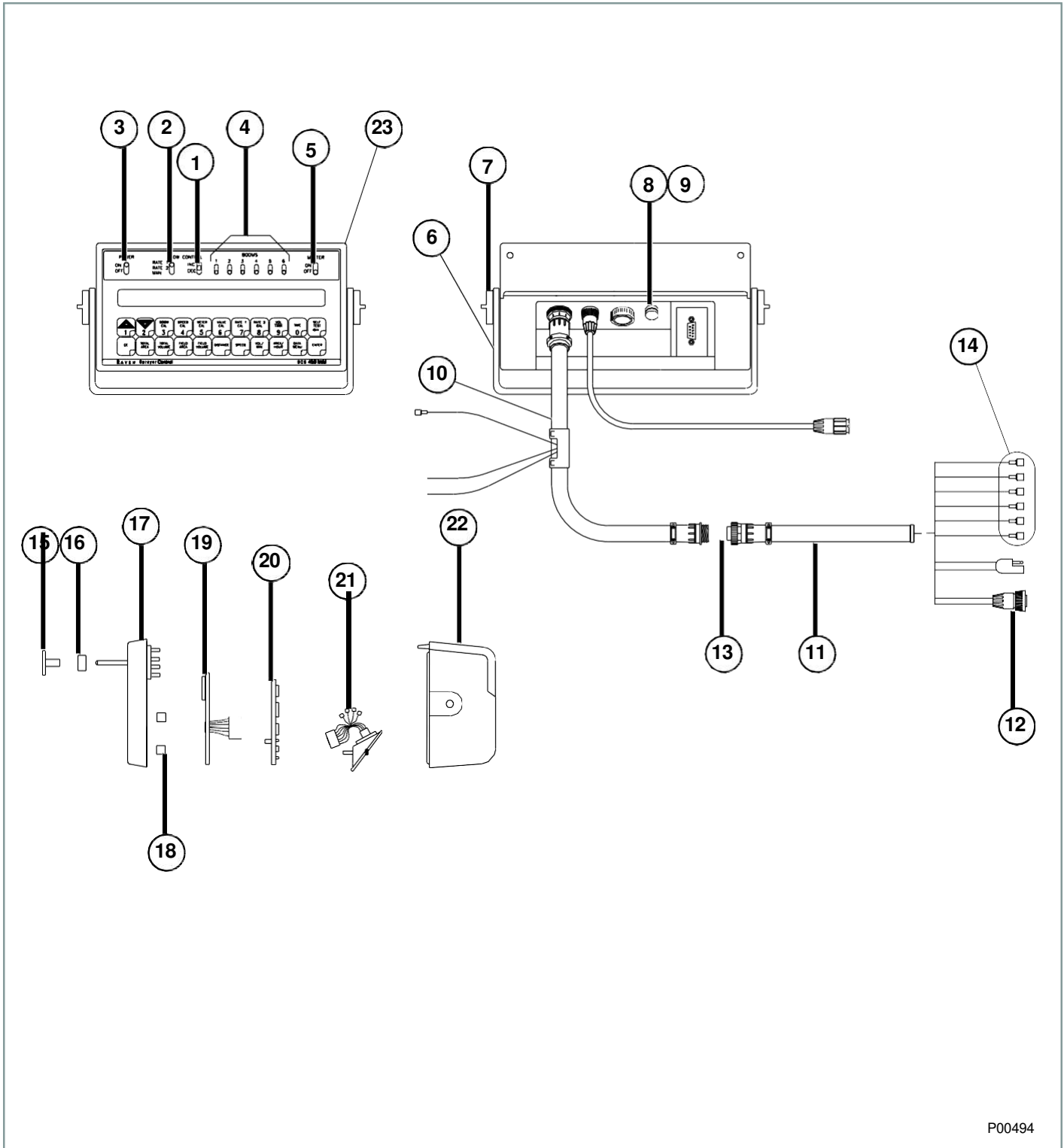

P00494



## ILLUSTRATED PARTS LIST (CONT'D)

### Raven SCS450 Console (Cont'd)

ITEM NO.	PART NO.	DESCRIPTION	QTY.
1	412-2011-049	MANUAL ADJ. SWITCH	1
2	019-0159-078	RATE1/RATE2/MANUAL SWITCH	1
3	412-2011-048	POWER SWITCH	1
4	412-2003-010	BOOM SWITCH	6
5	412-2011-046	MASTER SWITCH	1
6	106-0159-437	MOUNTING BRACKET	1
7	106-0159-438	MOUNTING KNOB	2
8	510-2001-018	FUSE HOLDER	1
9	510-1003-003	FUSE, 15 AMP.	1
10	115-0159-492	CONSOLE CONTROL CABLE (10 FT.)	1
	115-0159-707	CONSOLE CONTROL CABLE (3 FT.)	1
11	115-0159-495	FLOW CONTROL CABLE (6 FT.)	1
	115-0159-496	FLOW CONTROL CABLE (12 FT.)	1
	115-0159-708	FLOW CONTROL CABLE (24 FT.)	1
12	115-0159-016	FLOW METER CABLE EXT. (6 FT.)	1
	115-0159-017	FLOW METER CABLE EXT. (12 FT.)	1
13	115-0159-493	FLOW EXT. CABLE (12 FT.)	1
	115-0159-494	FLOW EXT. CABLE (24 FT.)	1
14	117-0159-402	ASSORTED TERMINAL KIT	6
15	063-0159-734	SWITCH COVER	1
16	117-0159-421	1-SET FILLER SPACERS	1
17	063-0172-024	FACE PLATE ASSEMBLY	1
18	107-0159-478	DISPLAY BOARD SPACER	2
19	063-0171-961	LCD DISPLAY BOARD	1
20	064-0159-745	PROCESSOR BOARD (SERIAL INTERFACE)	1
21	063-0172-022	CONNECTOR PLATE ASSEMBLY (SERIAL INTERFACE)	1
22	063-0159-530	BACK ASSEMBLY	1
23	063-0171-220	SCS 450 CONSOLE (SERIAL INTERFACE)	1

**ILLUSTRATED PARTS LIST (CONT'D)**

**Electrical Schematic Control Console Harness (115-0171-085)**

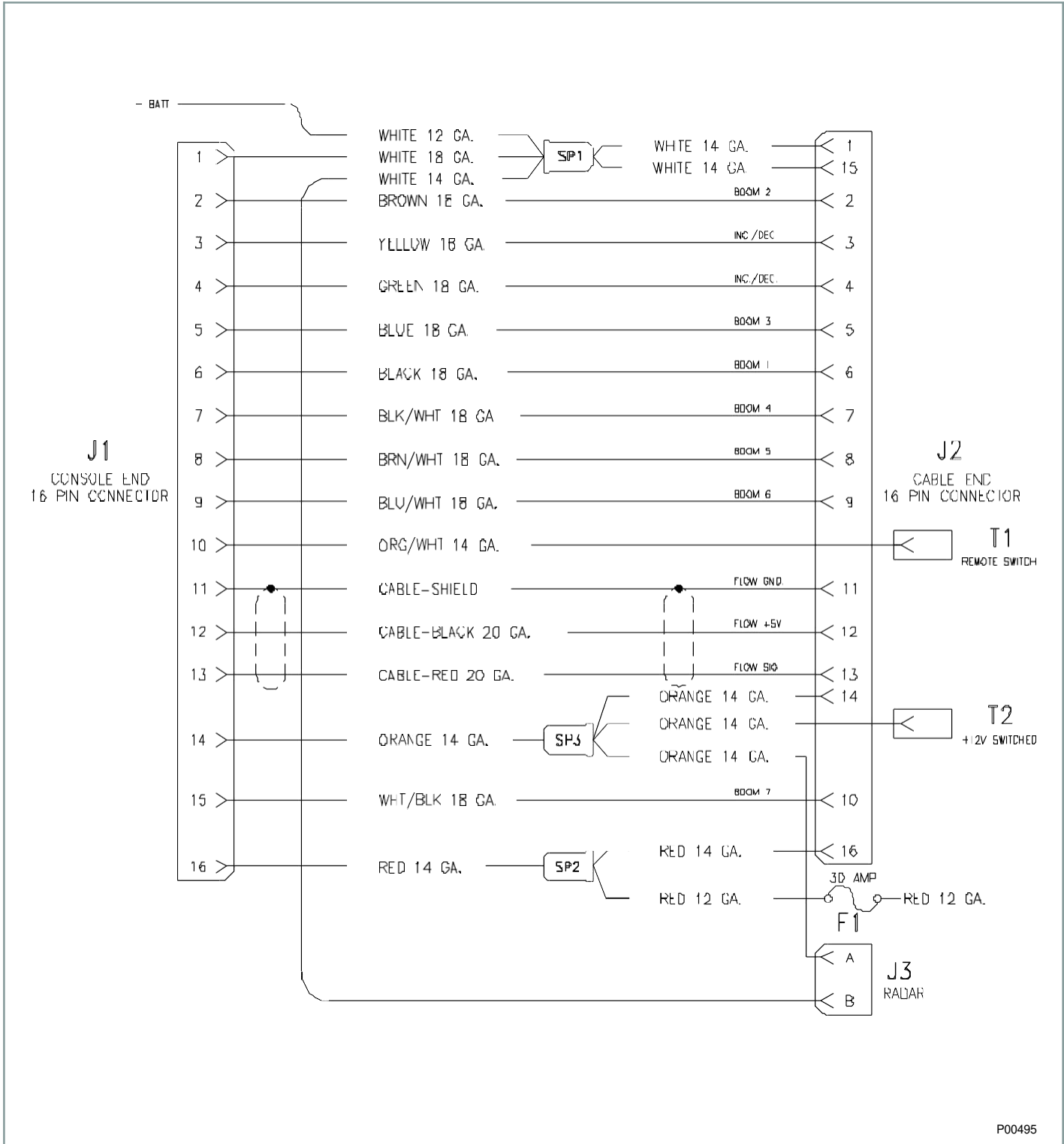

## SYSTEM SCHEMATICS

### Electrical Schematic Control Console Harness (115-0159-856)

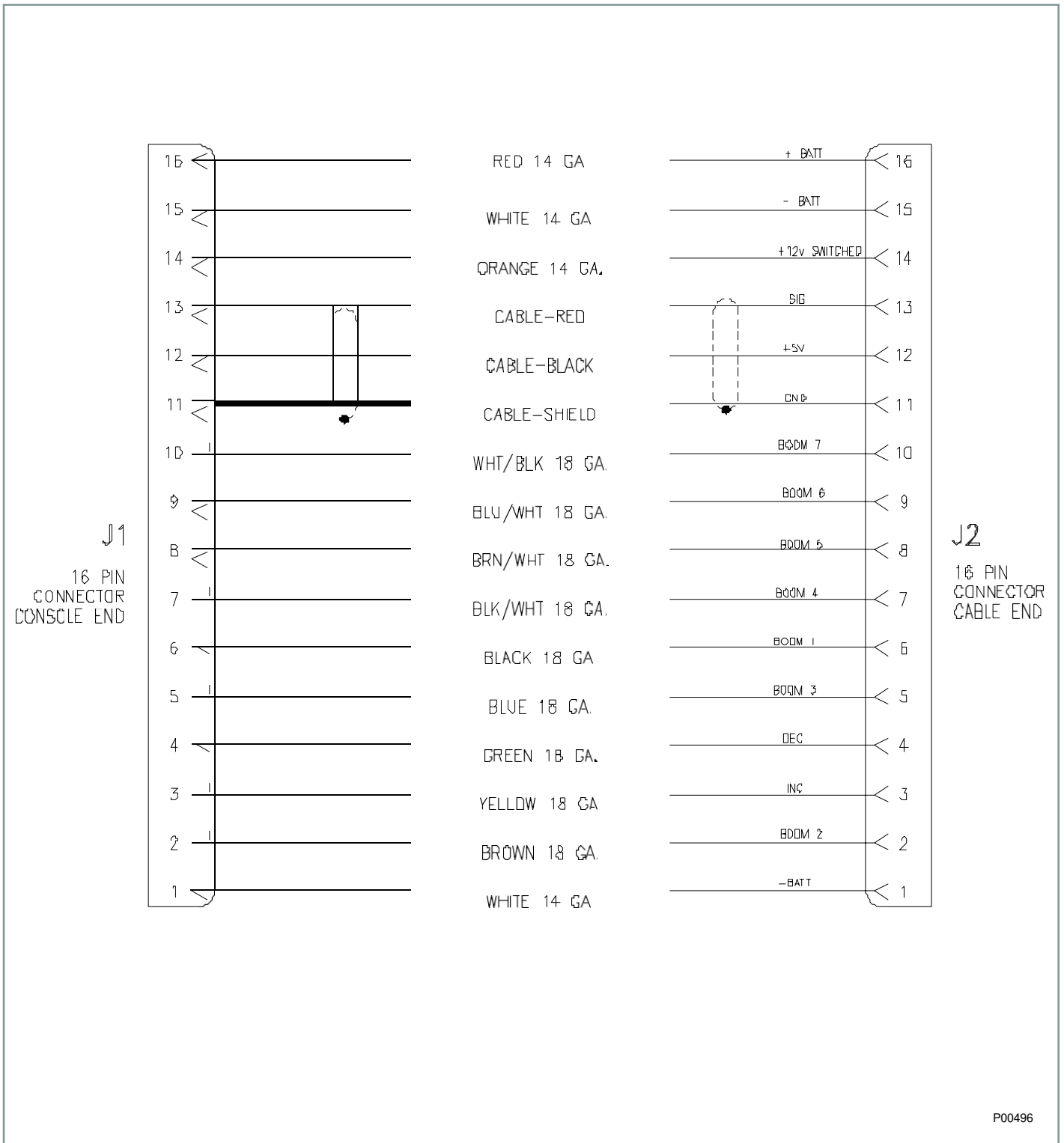

P00496

# SYSTEM SCHEMATICS

## Electrical Schematic Control Console Harness (115-0171-086)

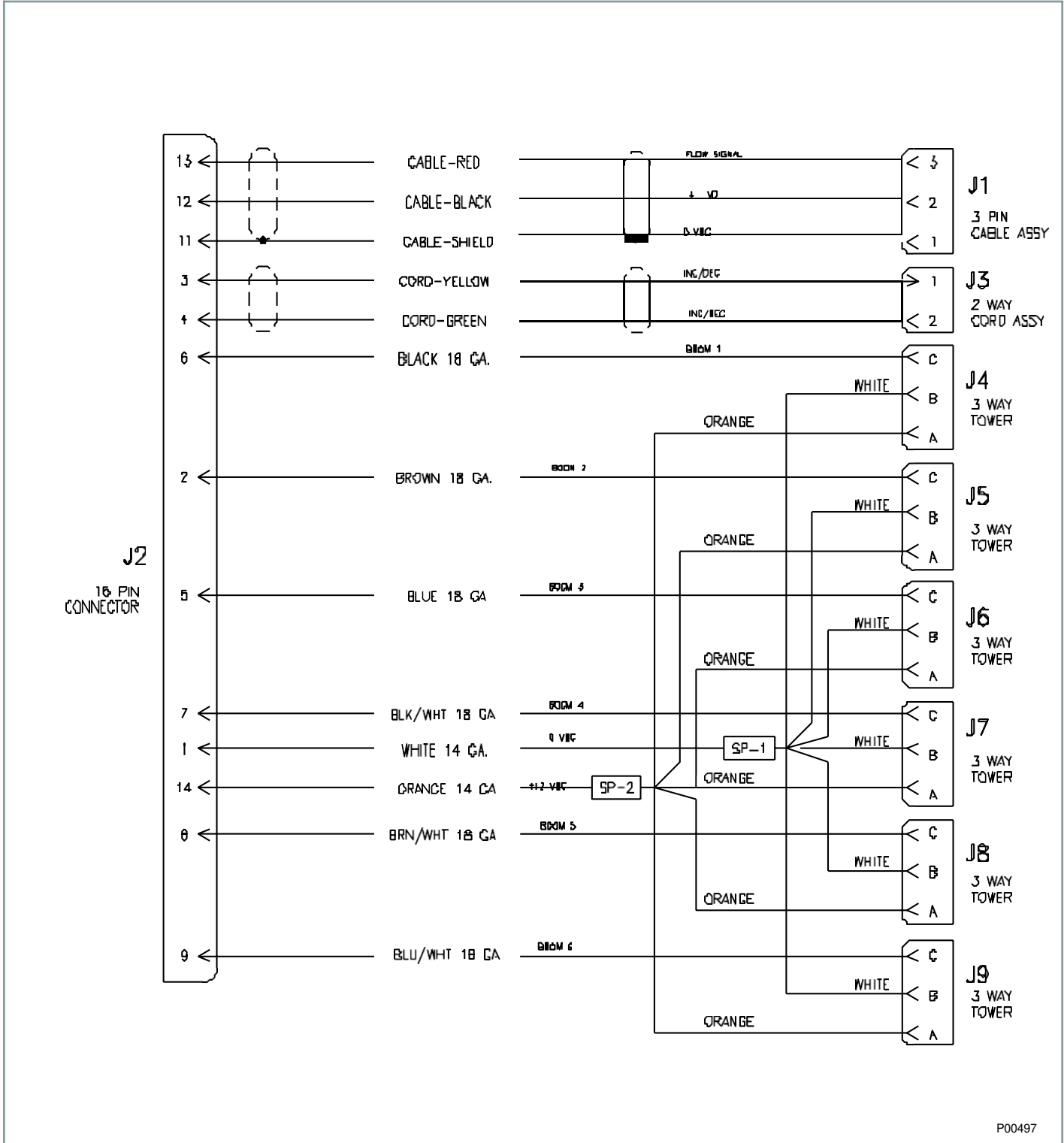

P00497



# ILLUSTRATED PARTS LIST (CONT'D)

## Raven, Cable 12 Ft. Product, 10 Boom Assembly (115-0171-313)

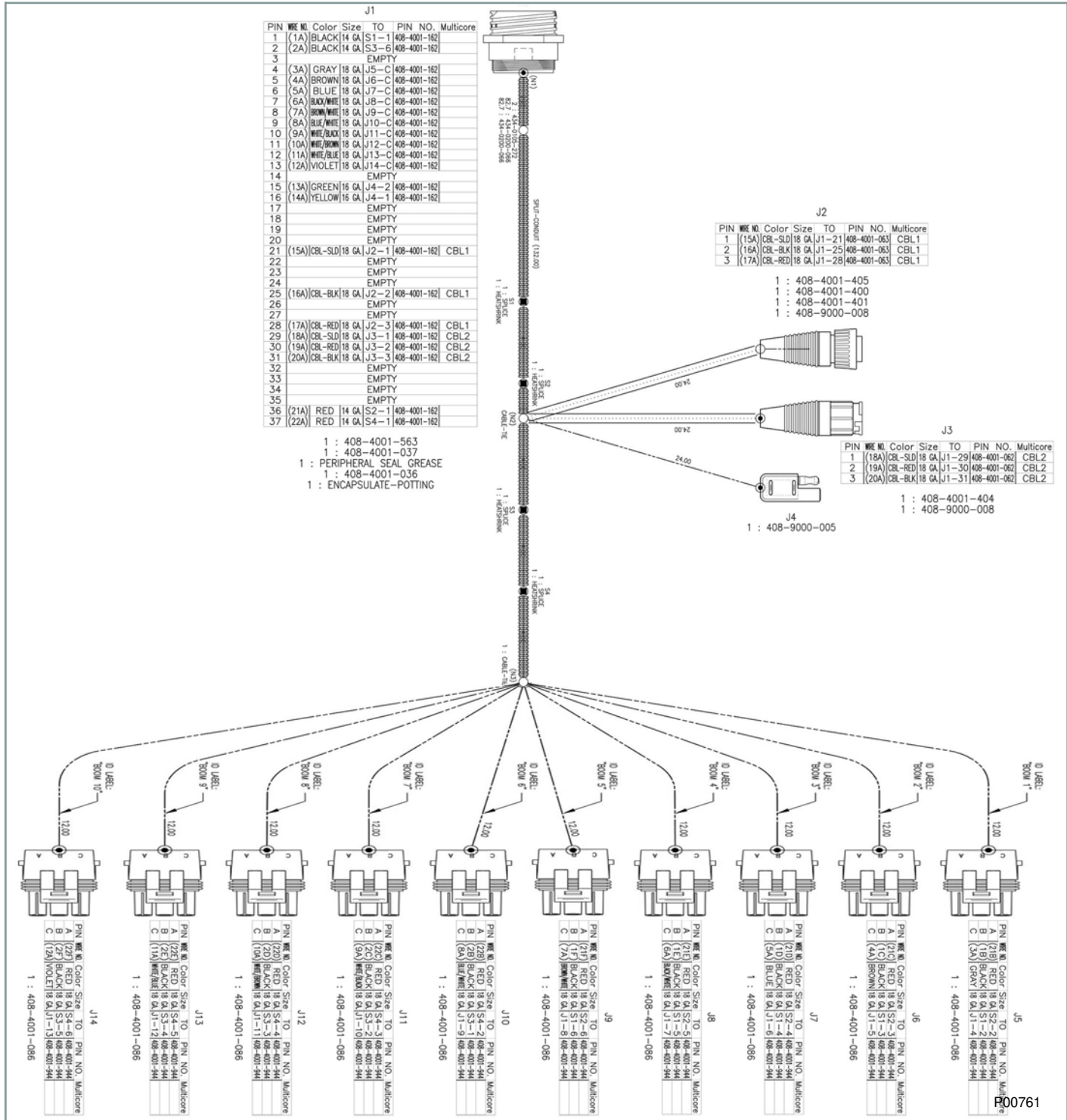

## ILLUSTRATED PARTS LIST (CONT'D)

### Raven, Cable 12 Ft. Product, 10 Boom Assembly (115-0171-313) (Cont'd)

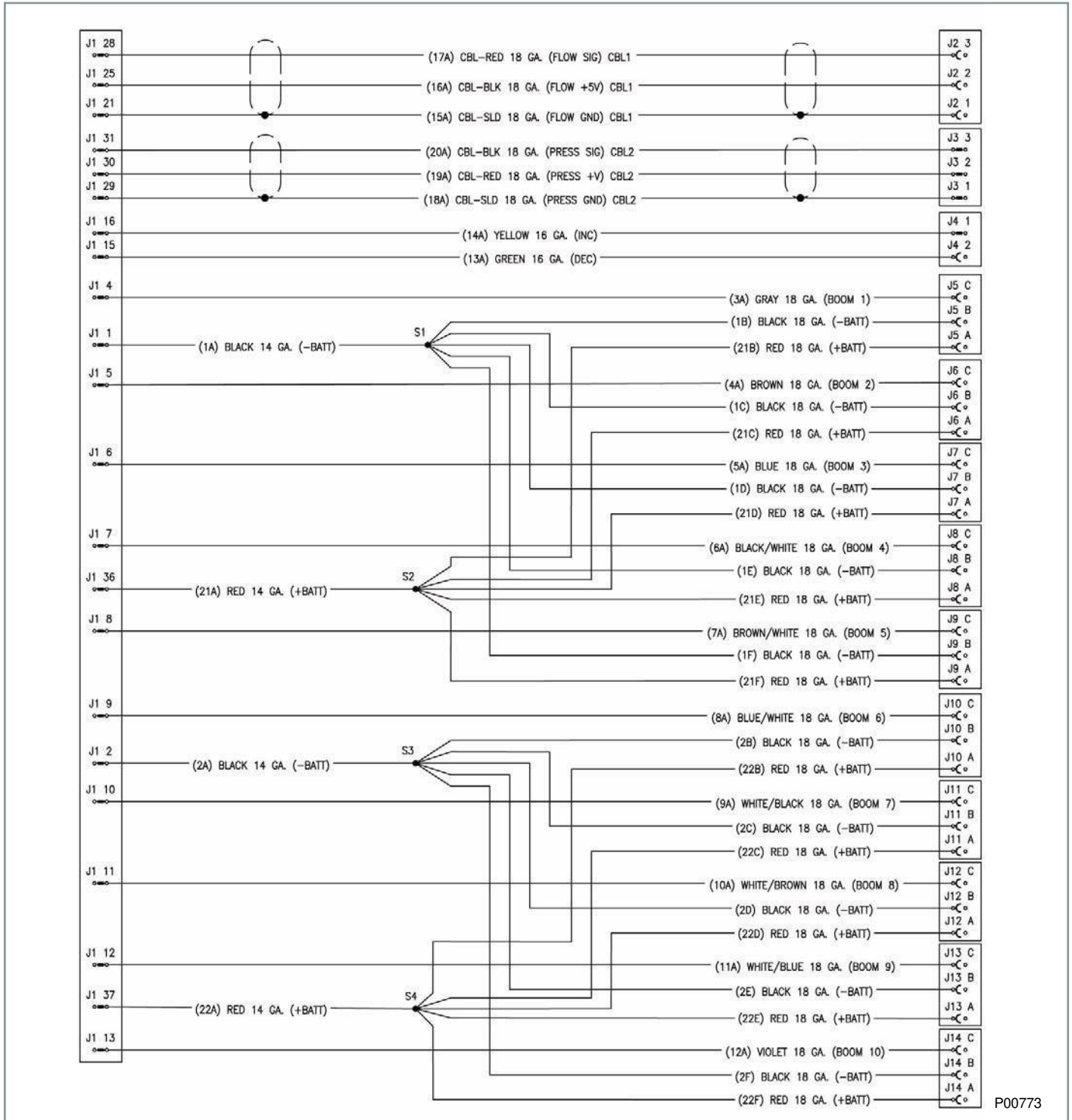

P00773

**ILLUSTRATED PARTS LIST (CONT'D)**

**Product Controller Liquid System, 16 Pin Product Cable**

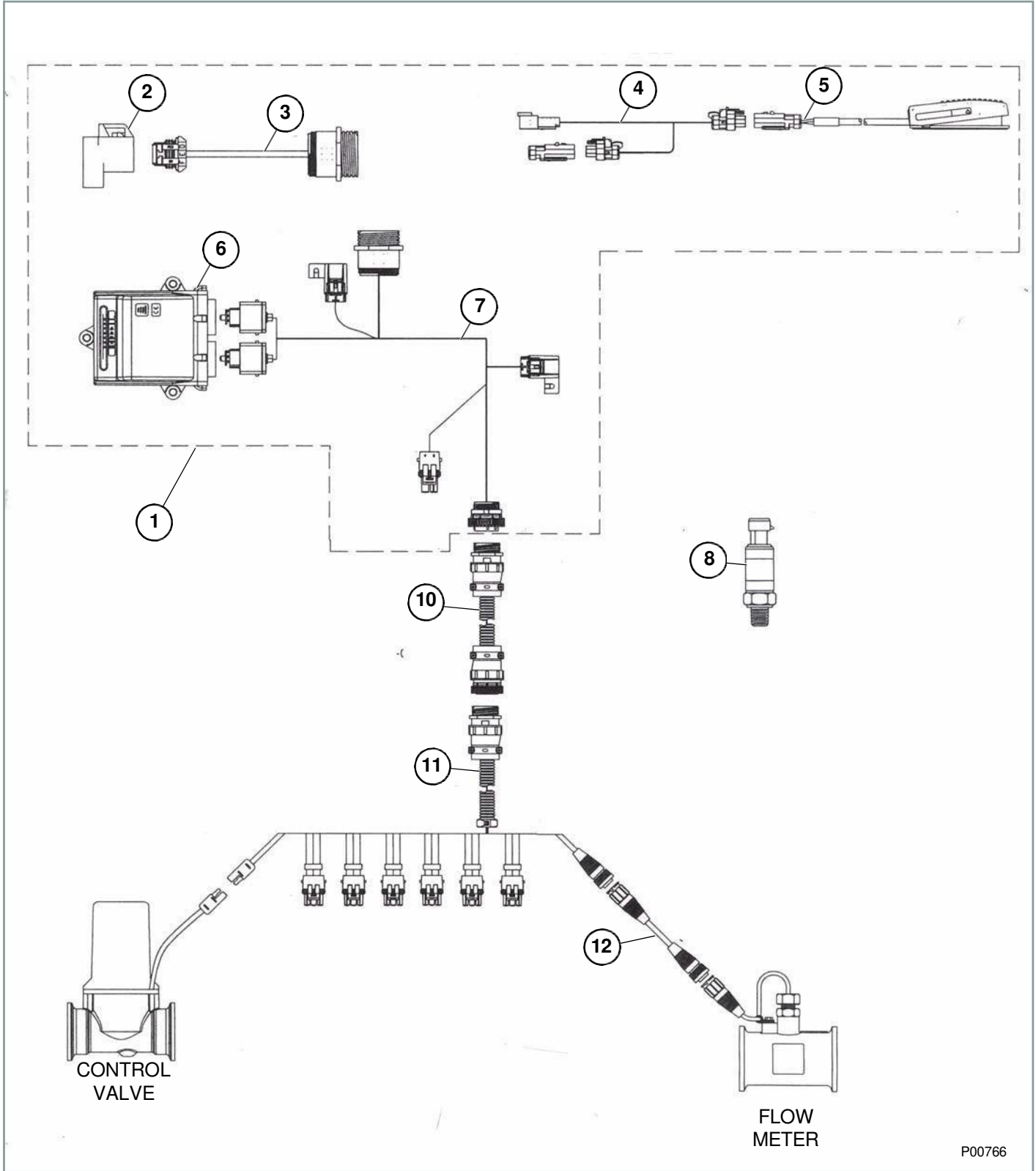



## ILLUSTRATED PARTS LIST (CONT'D)

### Product Controller Liquid System, 16 Pin Product Cable (Cont'd)

ITEM NO.	PART NO.	DESCRIPTION	QTY.
1*	117-6100-001	KIT, PRODUCT CONTROLLER, LIQUID 16 PIN	1
2	063-0172-964	TERMINATOR, ACTIVE, POWELL	1
3	115-0171-963	CABLE, RAVEN ISO TO ACTIVE TERMINATOR	1
4	115-0171-865	22 FT. FOOT SWITCH EXT	1
5	063-0173-080	FOOT SWITCH ISO NODE	1
6	063-0173-006	ISO PRODUCT CONTROLLER NODE	1
7	115-0171-949	PROD. CONTROLLER CABLE, 16 PIN	1
8	422-0000-090	PRESSURE SENSOR (OPTIONAL)	1
9	016-0171-362	PRODUCT CONTROLLER MANUAL (NOT SHOWN)	1
10	115-0159-856	12 FT. EXTENSION CABLE	1
	115-0159-857	24 FT. EXTENSION CABLE	
11	115-0171-086	12 FT. FLOW CABLE	1
	115-0171-129	24 FT. FLOW CABLE	
12	115-0159-016	6 FT. FLOW EXTENSION CABLE	1
	115-0159-017	12 FT. FLOW EXTENSION CABLE	
	115-0159-019	24 FT. FLOW EXTENSION CABLE	
	115-0171-544	36.5 FT. FLOW EXTENSION CABLE	

\* - Kit contains items 2 through 9.

**ILLUSTRATED PARTS LIST (CONT'D)**

**Product Controller Liquid System, 37 Pin Product Cable**

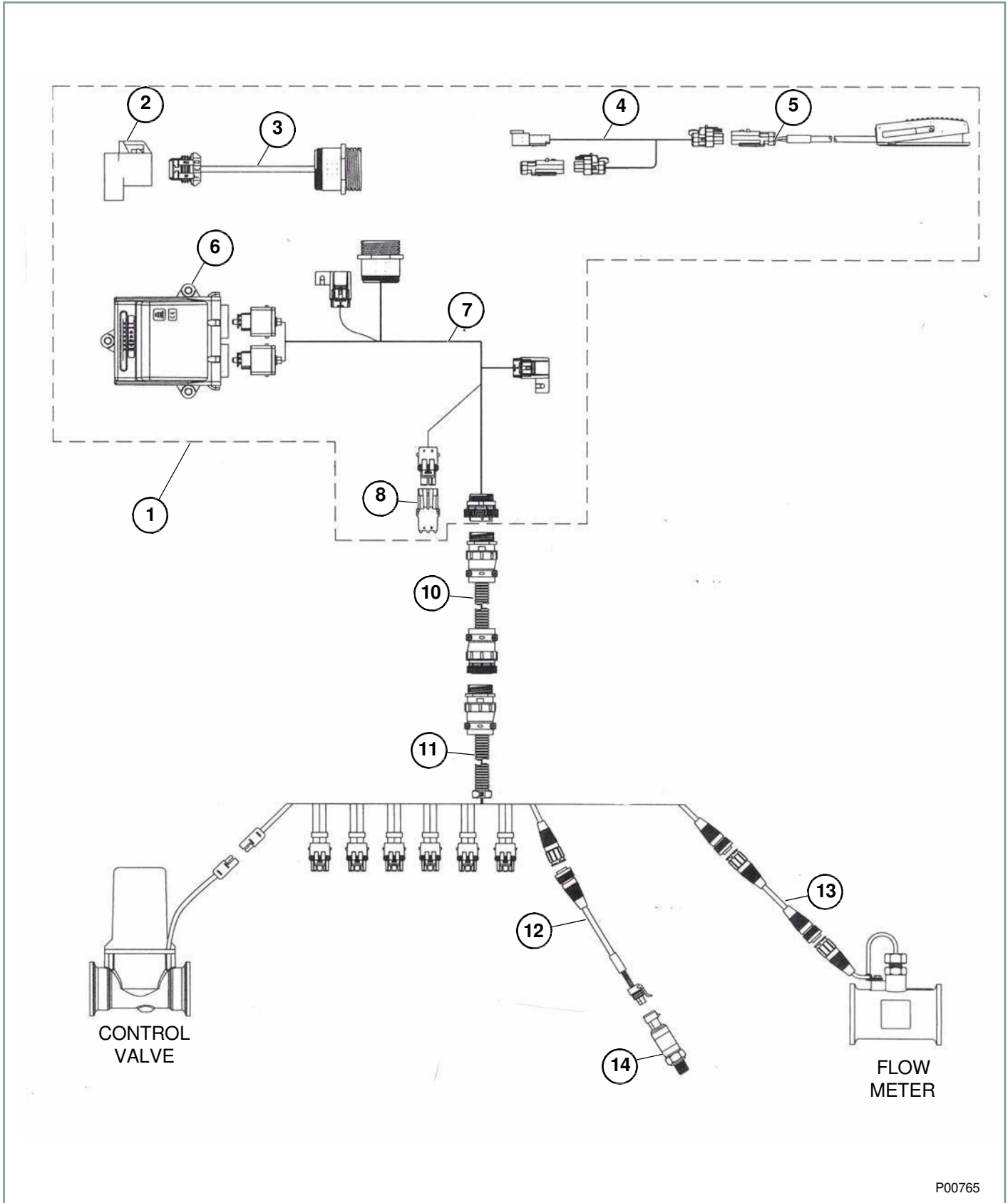

## ILLUSTRATED PARTS LIST (CONT'D)

### Product Controller Liquid System, 37 Pin Product Cable (Cont'd)

ITEM NO.	PART NO.	DESCRIPTION	QTY.
1*	117-6100-002	KIT, PRODUCT CONTROLLER, LIQUID/GRANULAR 37 PIN	1
2	063-0172-964	TERMINATOR, ACTIVE, POWELL	1
3**	115-0171-963	CABLE, RAVEN ISO TO ACTIVE TERMINATOR	1
4	115-0171-865	22 FT. FOOT SWITCH EXT	1
5	063-0173-080	FOOT SWITCH ISO NODE	1
6	063-0173-006	ISO PRODUCT CONTROLLER NODE	1
7***	115-0171-945	PROD. CONTROLLER CABLE, 37 PIN	1
8	NA	DUST CAP	1
9	016-0171-362	PRODUCT CONTROLLER MANUAL (NOT SHOWN)	1
10	115-0171-319	12 FT. EXTENSION CABLE	1
	115-0171-320	24 FT. EXTENSION CABLE	
11	115-0171-313	12 FT. FLOW CABLE 10 BOOM	1
	115-0171-314	24 FT. FLOW CABLE 10 BOOM	
	115-0171-315	12 FT. FLOW CABLE 5 BOOM	
	115-0171-316	24 FT. FLOW CABLE 5 BOOM	
12	115-0171-235	6 FT. PRESSURE SENSOR CABLE	1
	115-0171-151	12 FT. PRESSURE SENSOR CABLE	
	115-0171-224	37 FT. PRESSURE SENSOR CABLE	
	115-0171-296	44 FT. PRESSURE SENSOR CABLE	
13****	115-0159-016	6FT. FLOW EXTENSION CABLE	1
	115-0159-017	6FT. FLOW EXTENSION CABLE	
	115-0159-019	6FT. FLOW EXTENSION CABLE	
	115-0171-544	6FT. FLOW EXTENSION CABLE	
14	422-0000-090	PRESSURE SENSOR (OPTIONAL)	1

\* - Kit contains items 2 through 9.

\*\* - For more information on the cable see *Raven, Cable, Adapter, ISO To Active Terminator Assembly (115-0171- 963)* on Page 144.

\*\*\* - For more information on the cable see *Raven, Cable 4400/4600 Interface, 37 Pin Product Controller Assembly (115-0171-945)* on Page 142.

\* - Can be used for pressure sensor extensions.

# ILLUSTRATED PARTS LIST (CONT'D)

## Cable, 17 Ft., ISO, Hitch To Raven ECU Assembly (115-0172-034)

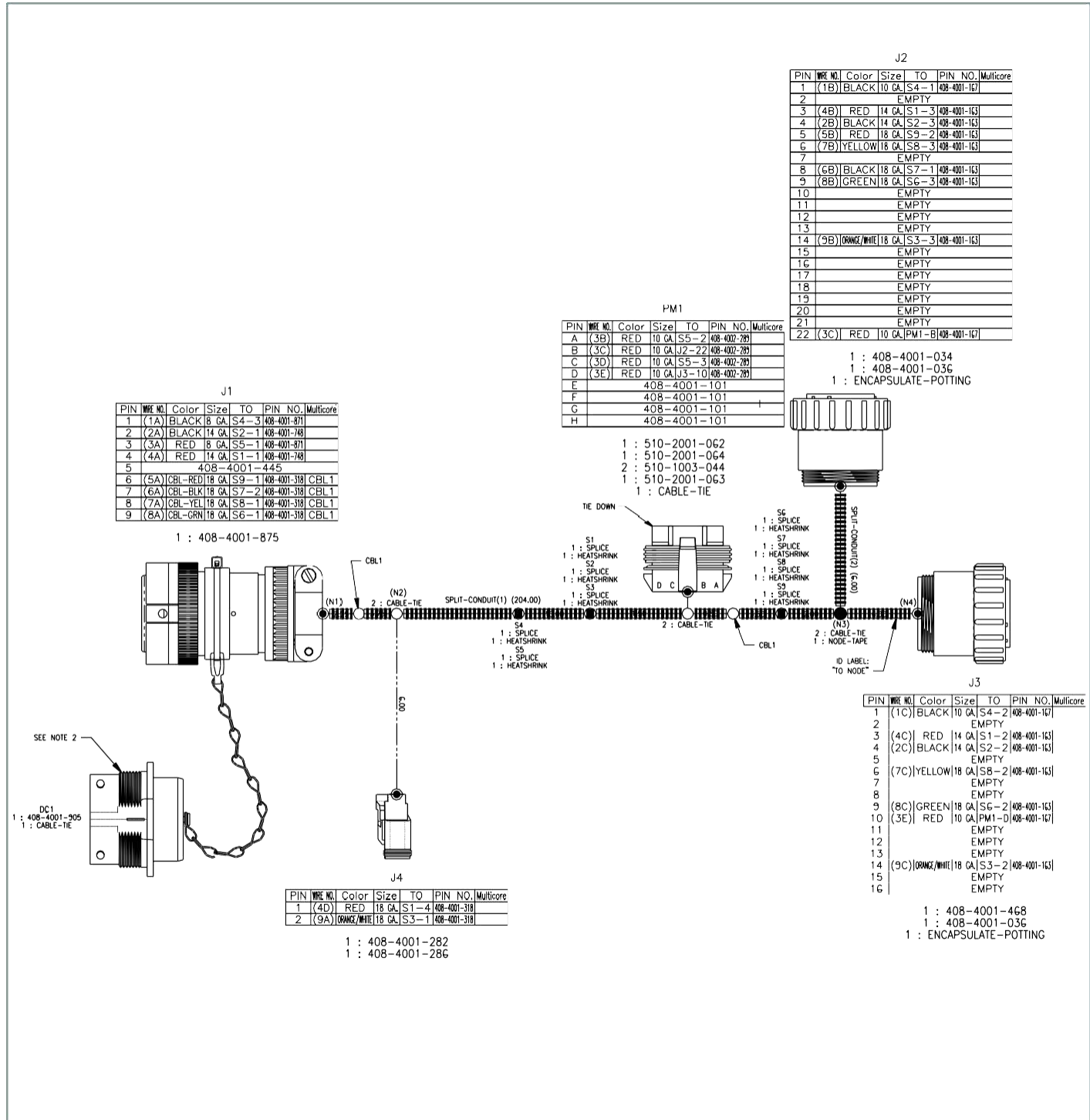

ITEM NO.	PART NO.	DESCRIPTION	QTY.
1	115-0172-034	RAVEN, CABLE, 17 FT., ISO, HITCH TO RAVEN ECU ASSEMBLY	1

## ILLUSTRATED PARTS LIST (CONT'D)

### Cable, 17 Ft., ISO, Hitch To Raven ECU Assembly (115-0172-034) (Cont'd)

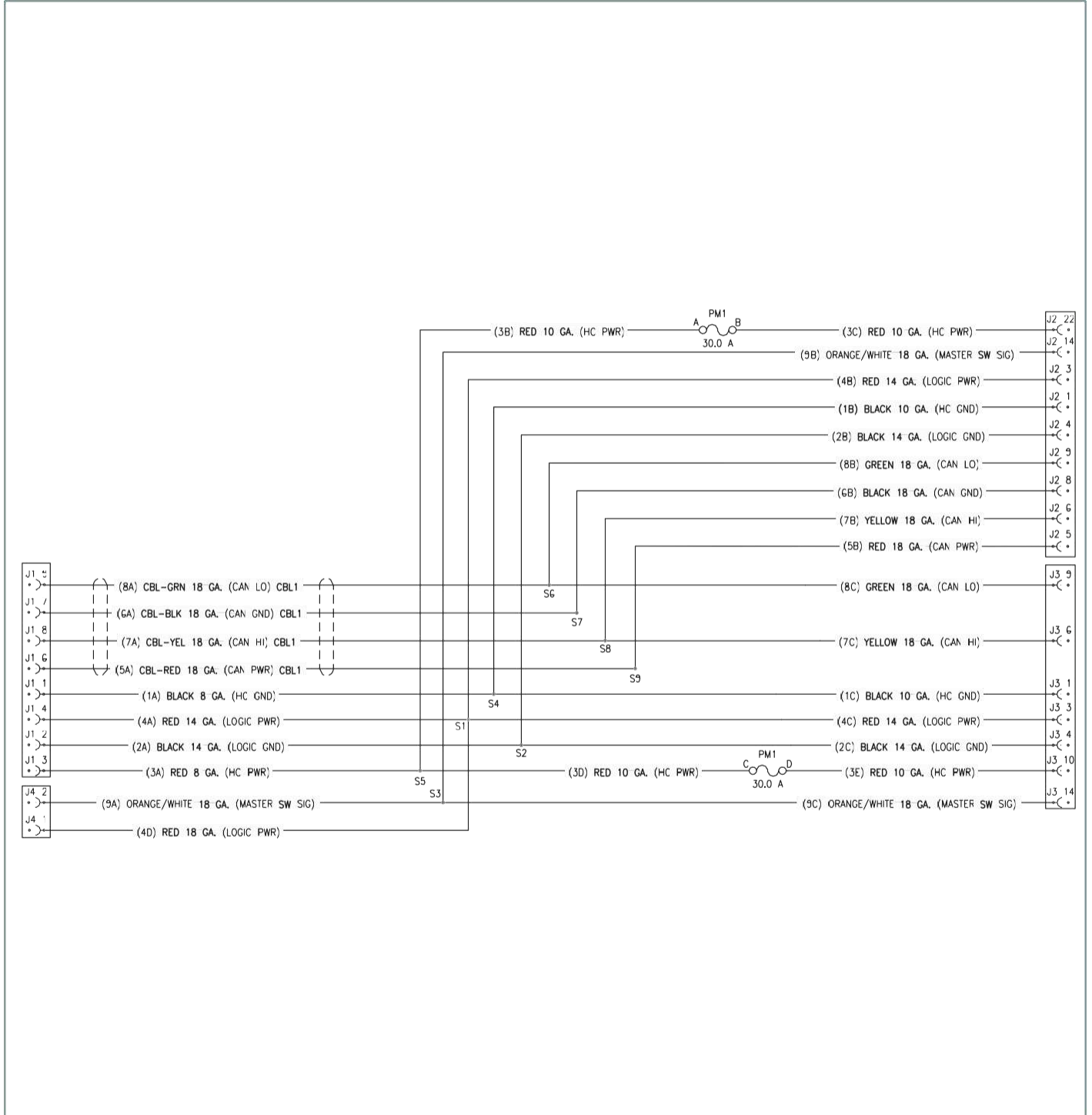

P00775



## ILLUSTRATED PARTS LIST (CONT'D)

### Raven, Cable 4400/4600 Interface, 37 Pin Product Controller Assembly (115-0171-945) (Cont'd)

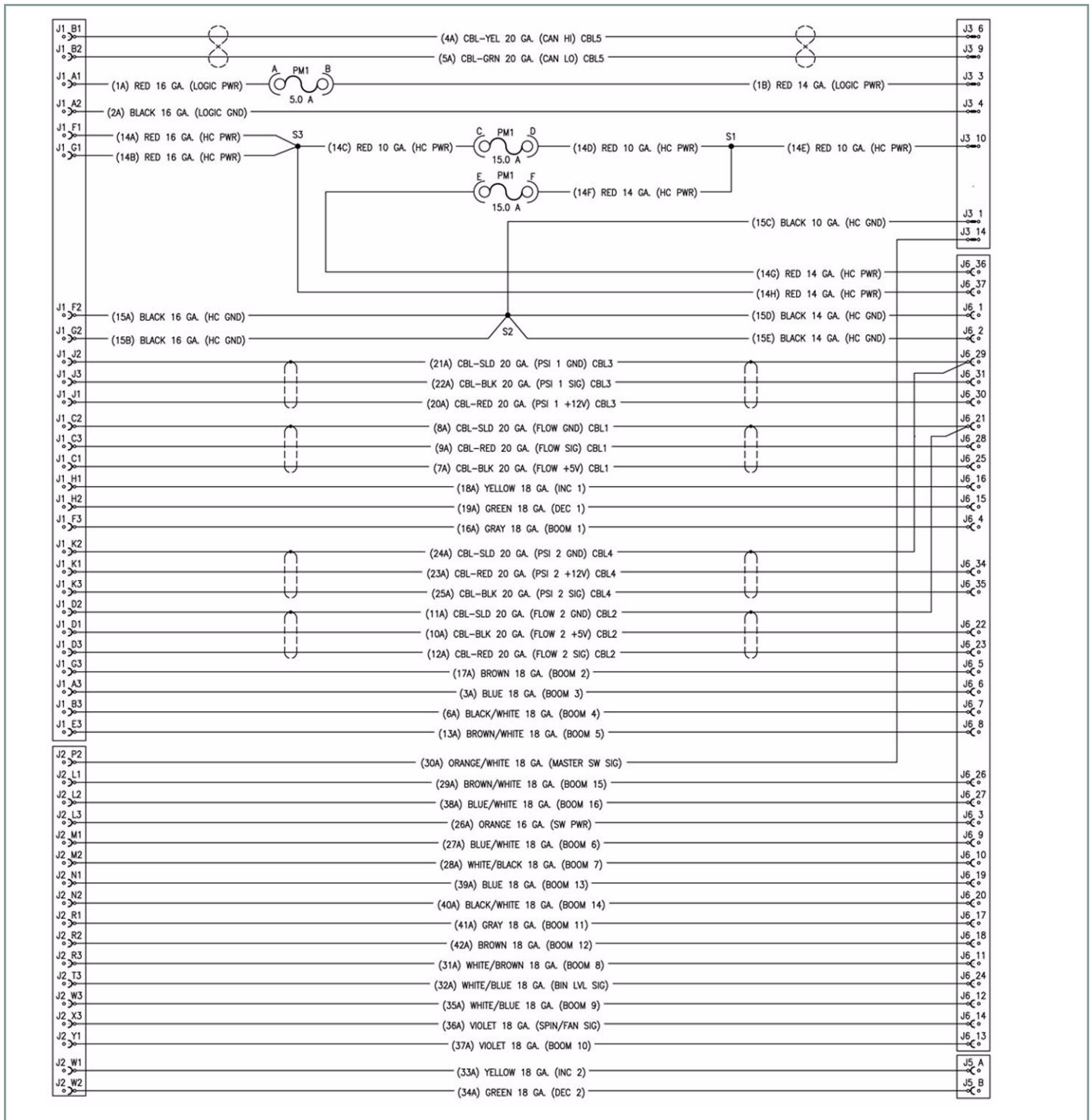

P00772

# ILLUSTRATED PARTS LIST (CONT'D)

## Raven, Cable, Adapter, ISO To Active Terminator Assembly (115-0171-963)

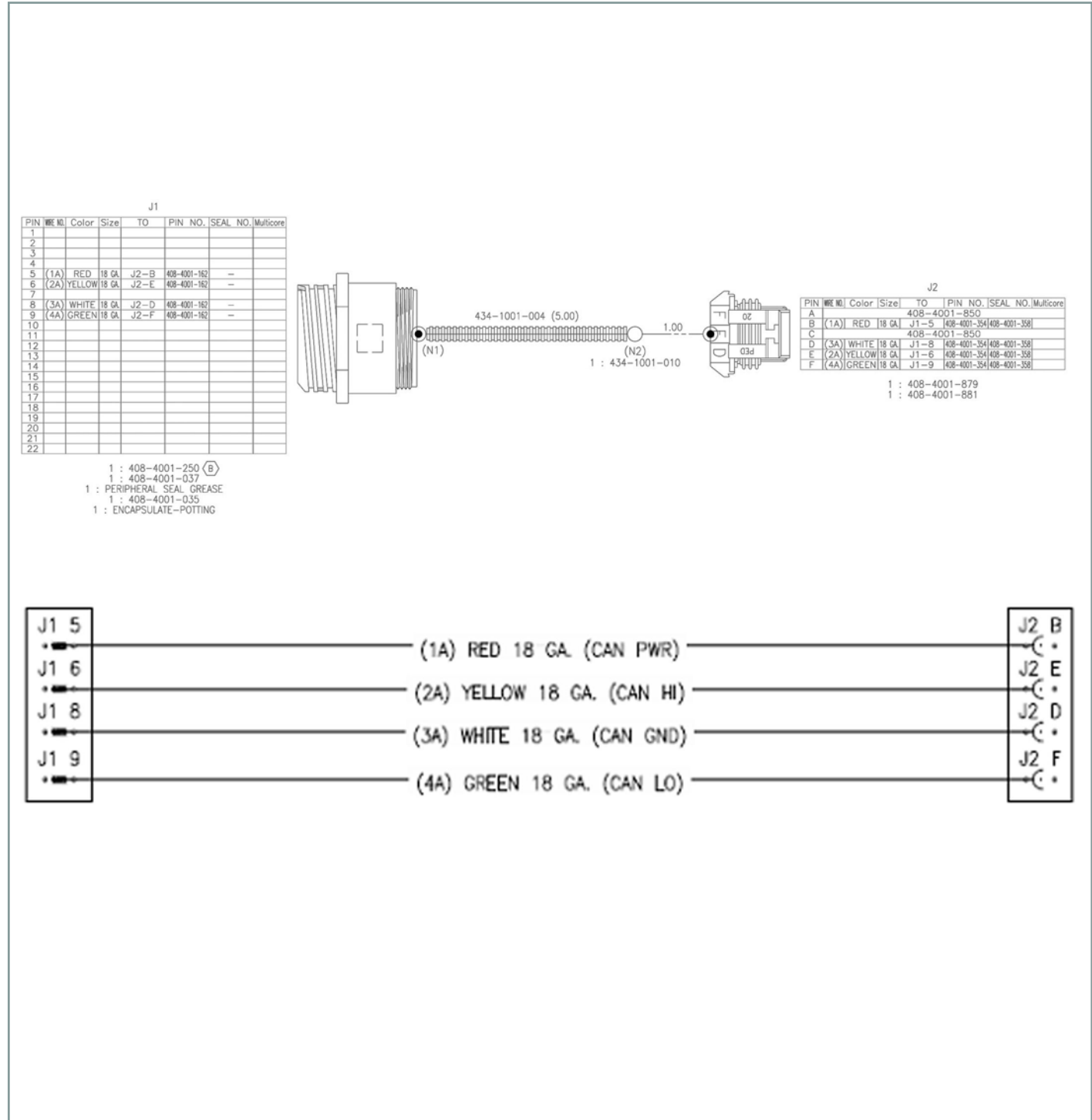

ITEM NO.	PART NO.	DESCRIPTION	QTY.
1	115-0171-963	RAVEN, CABLE ISO TO ACTIVE TERMINATOR ASSEMBLY	1





ILLUSTRATED PARTS LIST (CONT'D)

Fold Control Cab Box (304-041)

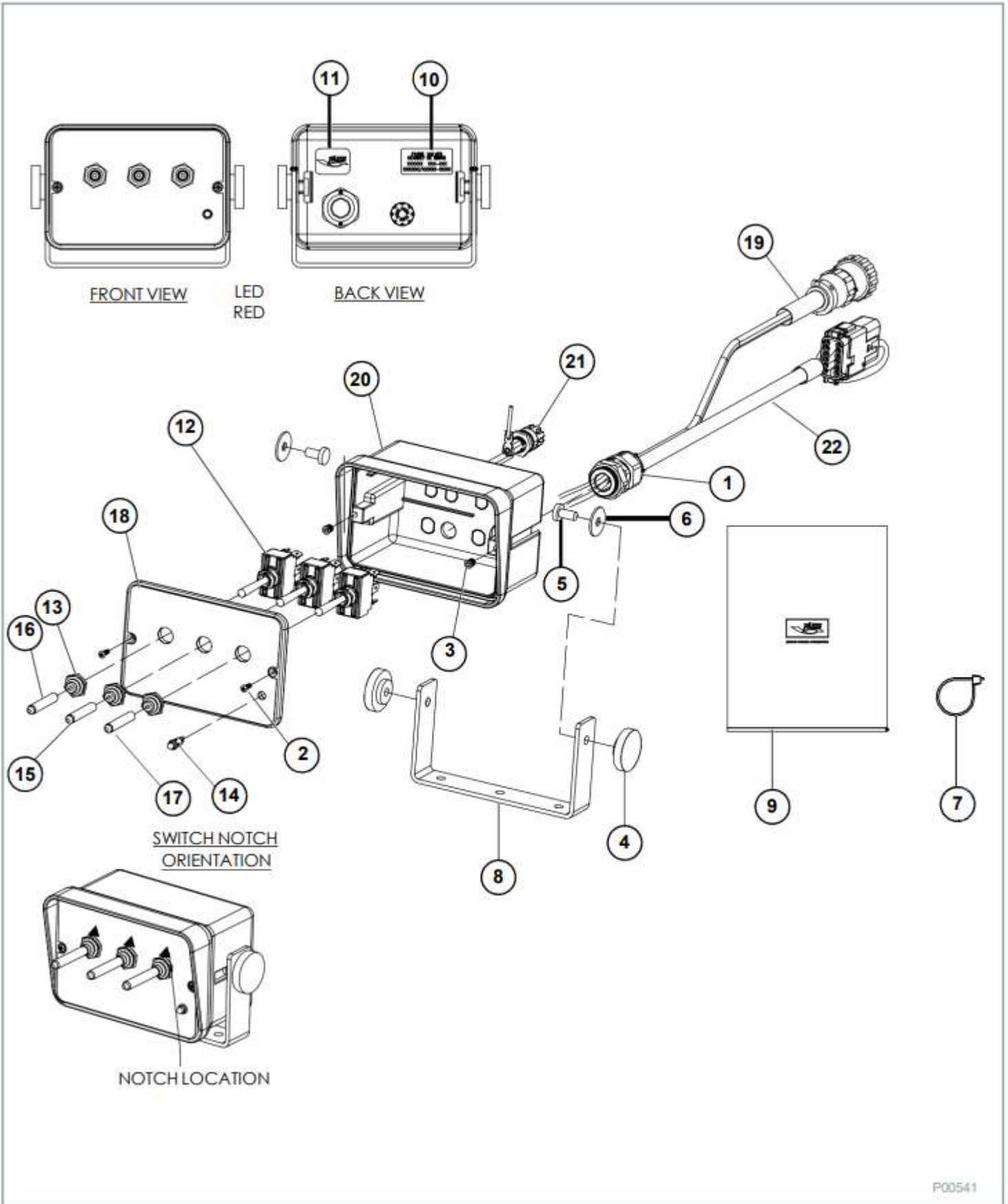

P00541

## ILLUSTRATED PARTS LIST (CONT'D)

### Fold Control Cab Box (304-041) (Cont'd)

ITEM NO.	PART NO.	DESCRIPTION	QTY.
1	210-710	STR RLF HEYCO 0.23 - 0.53 ID HOLE DIA 0.886	1
2	212-184	SCREW 6-32 X 3/8 OVAL HD BLK	2
3	212-202	INSERT 6-32 X 3/8 BRASS	2
4	212-215	KNOB 1/4-20 FEMALE	2
5	212-231	SCREW, WELDED 1/4-20 X 0.500	2
6	213-335	WASHER NYLON 0.257 X 0.875 X 0.060	2
7	214-002	CABLE TIE BLACK 7"	3
8	219-300	BRACKET HOUSING MONITOR	1
9	230-057	BAG POLY CLEAR 14 X 18 2 MIL W/LOGO	1
10	232-050	DECAL S/N SILVER	2
11	232-058	DECAL GOLD/BLACK 1 X 0.75	1
12	250-013	SW TOG DPDT 3P MOM LONG	3
13	250-023	SW TOG BOOT OPN GREY	4
14	254-350	LED RED T-1 3/4 PANEL MNT 12V 6 IN. LEADS	1
15	259-022	SW TOG GRIP VINYL YELLOW 0.187	1
16	259-023	SW TOG GRIP VINYL GREEN 0.187	1
17	259-027	SW TOG GRIP VINYL GREY 0.187	1
18	304-040	ENCL DRILL FP MNTR SW3 F00204	1
19	314-001	HRN 2CON 14GA AMP PLUG 3P(2) 8'	1
20	319-725	ENCL DRILL MNTRBX FH-7/8" STR RLF	1
21	319-769	FUSEHOLDER PM ASSM. 10A /.5'	1
22	320-714	HRN 12CON 18GA KEY A DTP12P(12) 11' END CAP F00204	1
NS	304-041	CAB BOX COMPLETE (CONTAINS ITS 1-22)	1

**ILLUSTRATED PARTS LIST (CONT'D)**

**Wiring Harness Connection (314-217)**

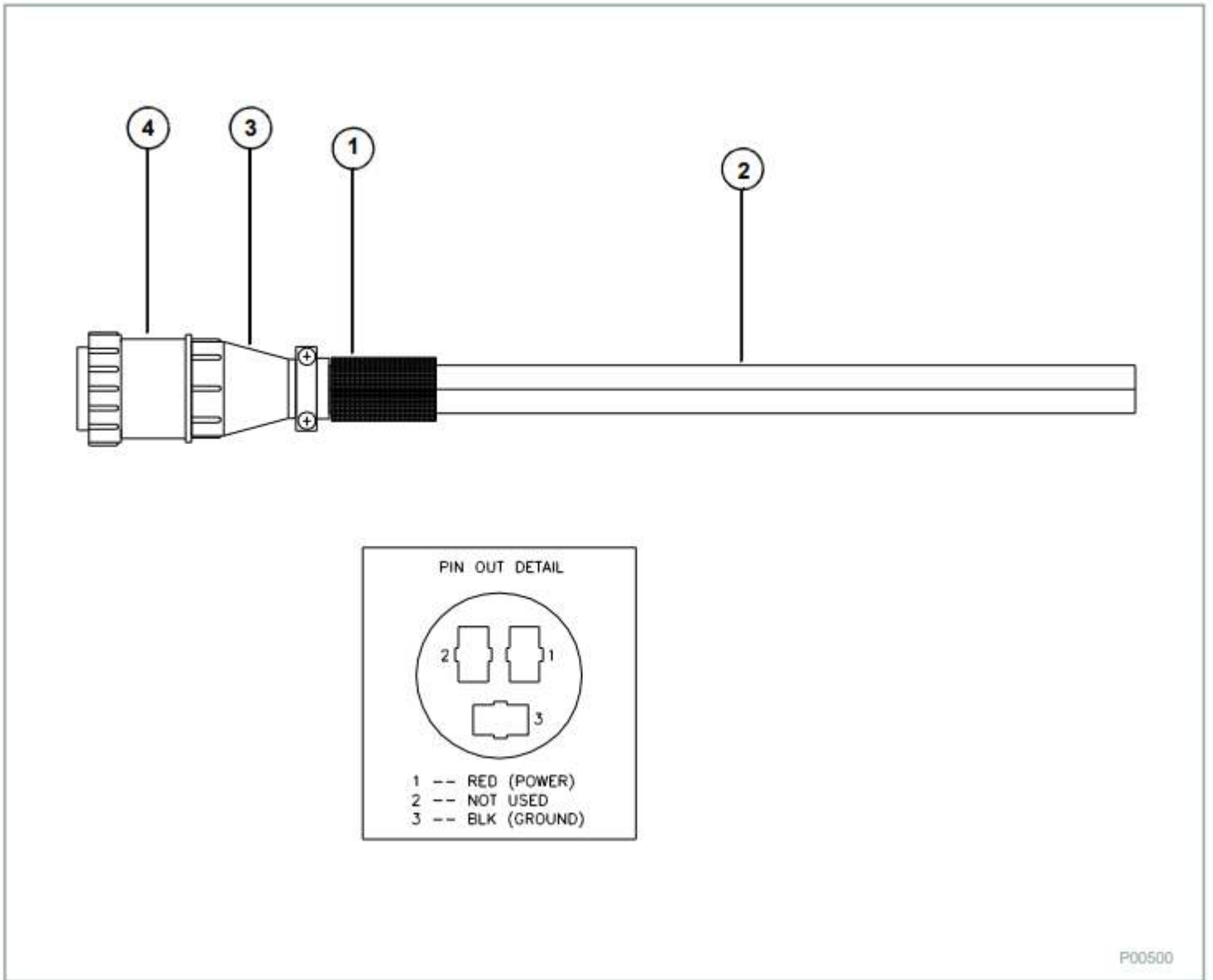

ITEM NO.	PART NO.	DESCRIPTION	QTY.
1	230-250	SHRINK TUBING 0.250 BLACK 2 IN. (51 MM)	1
2	252-021	WIRE RED/BLACK 16 GA ZIP 8 FT. (2439 MM)	1
3	255-043	CENTER 16 PIN SHELL #17	1
NS	255-233	CENTER AMP SOCKET	1
5	255-549	CENTER SERIES 3 17-3 PLUG	1
5	314-217	POWER HARNESS (CONTAINS ITEMS 1-5)	1

## ILLUSTRATED PARTS LIST (CONT'D)

### Harness Connector (319-759)

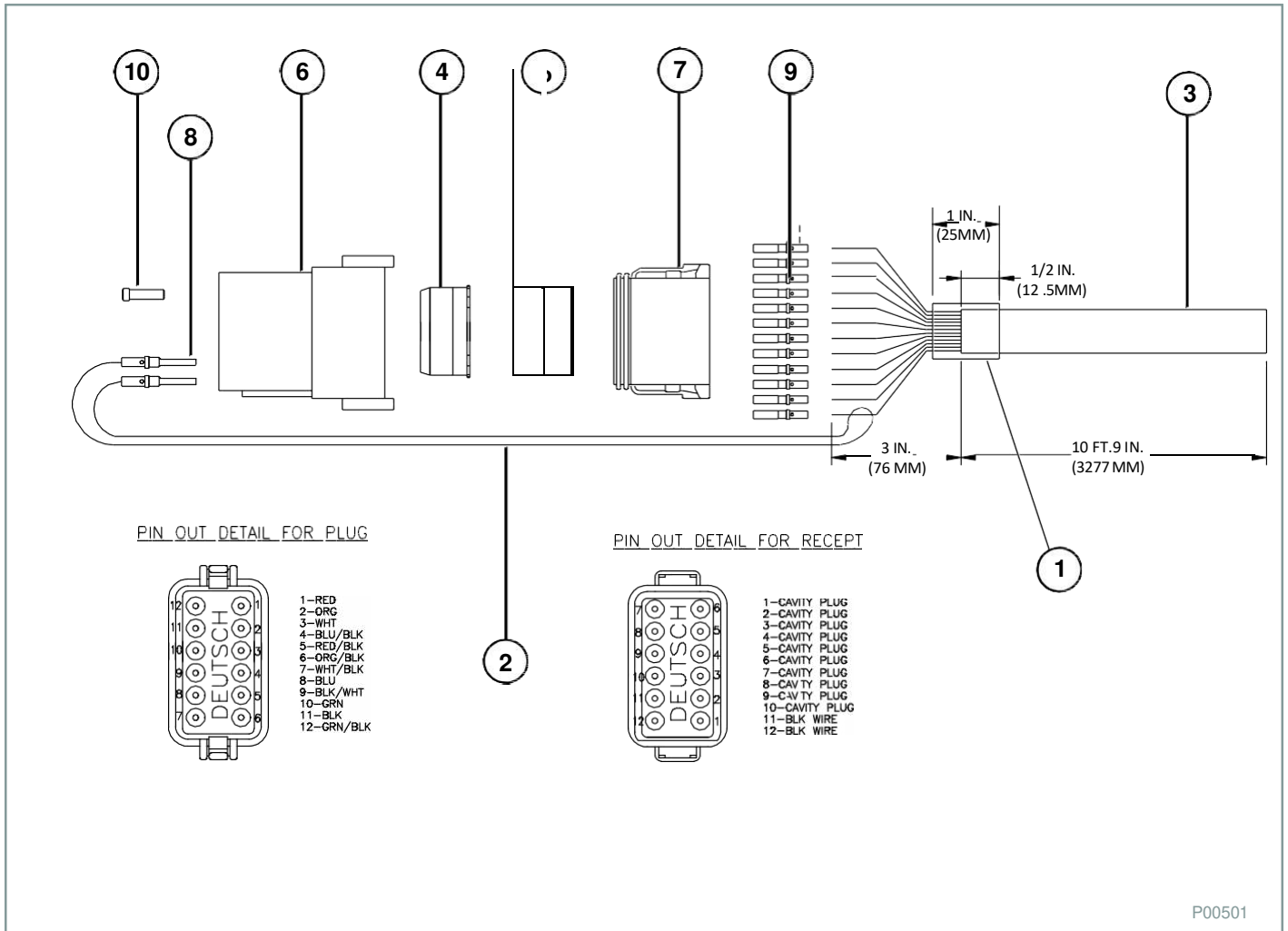

ITEM NO.	PART NO.	DESCRIPTION	QTY.
1	231-009	SHRINK TUBING 0.500 BLACK 1 IN. (25 MM)	1
2	252-058	WIRE BLACK 18 GA 12 IN. (305 MM)	1
3	252-064	CABLE 12 CON 18 GA PVC GREY 11 IN. (280 MM)	1
4	255-214	CONN DUET LOCK WEDGE 12 PIN DTR	1
5	255-215	CENTER LOCK WEDGE 12 PIN DTR	1
6	255-755	CONN DUET DT RCPT 12 PIN KEY A	1
7	255-756	CONN DUET DT PLUG 12 PIN KEY A	1
8	255-977	CONN DUET PIN 16-18 GA	2
9	255-978	CENTER DUETSCH SOCKET 16/18 GA.	12
10	255-979	CONN DUET CAVITY PLUG	10
	319-759	CONTROL HARNESS (CONTAINS ITEMS 1-10)	10



## ILLUSTRATED PARTS LIST (CONT'D)

### Fold Control Block Harness (304-042) (Cont'd)

ITEM NO.	PART NO.	DESCRIPTION	QTY.
1	231-006	SHRINKTUBINE 0.375 IN. BLK DUAL WALL	11 IN.
2	231-009	SHRINKTUBING 0.5 IN.	3 IN.
3	231-011	SHRINKTUBINE 0.75 IN. BLK DUAL WALL	6 IN.
4	252-006	CABLE 3CON 18GA PVC GRY	24 FT.
5	252-058	WIRE 18GA BLK	146 IN.
6	252-064	CABLE 12CON 18GA GRY	35 FT.
7	255-191	CONT DEUT CAVITY PLUG SZ20RED	2
8	255-214	CNTR DEUTSCH LOCK WEDGE 12PIN DTP	1
9	255-215	CONN DEUT LOCK WEDGE 12PIN DTP	1
10	255-285	TRM SPLICE CLOSED END LRG 12-10GA	1
11	255-319	CONT DEUT SOCKET DTM 16-18GA	6
12	255-320	CONT DEUT SOCKET DTM 4P	2
13	255-321	CONT DEUT LOCK WEDGE 4P PLUG ORG	2
14	255-322	RLY HELLA CUBE SPDT 12V 20/40 SKIRT	1
15	255-323	RLY SOCKET HELLA CUBE 5P SEALED W/LE	1
16	255-505	CNTR DEUTSCH LOCK WEDGE 2PIN DTP	8
17	255-755	CONT DEUT DT RCPT 12P KEY A	1
18	255-756	CONT DEUT DT PLUG 12P KEY A	1
19	255-801	CNTR DEUTSCH 16/18GA	8
20	255-977	TRM PIN DEUTSCH 16/18GA	12
21	255-978	TRM SOCKET DEUTSCH 16/18GA	18
22	255-979	CONT DEUT CAVITY PLUG	10
	304-042	BLOCK HARNESS (CONTAINS ITEMS 1-22)	1

**ILLUSTRATED PARTS LIST (CONT'D)**

**Valve Block And Harness (303-131)**

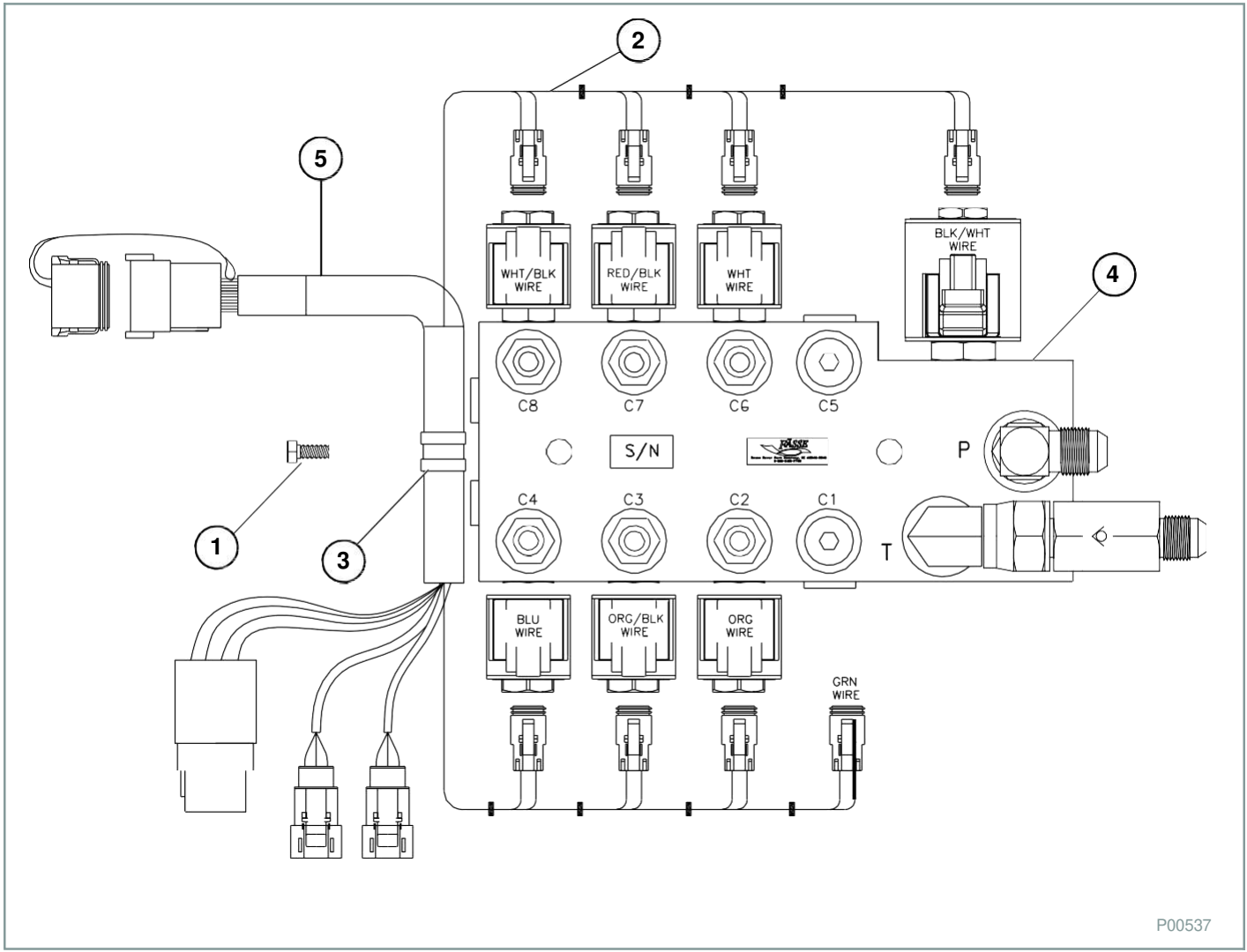

P00537

ITEM NO.	PART NO.	DESCRIPTION	QTY.
1	212-025	BOLT 5/16-18 X 0.75	1
2	214-002	CABLE TIE BLACK	11
3	255-026	LOOM CLAMP 0.5" ID METAL/RUBBER	1
4	302-469	MANIFOLD ASSEMBLY	1
5	304-042	HRN ASSY 12CON 18GA DTR KEY A 12P(12)-8DPT2P(2) 33'	1
	303-131	VALVE BLOCK AND HARNESS (ITEMS 1-5)	1





## ILLUSTRATED PARTS LIST (CONT'D)

### Control Box To Control Valve Operation And Pin-Out Location

SWITCH	SWITCH POSITION	SIGNAL WIRES	PIN-OUT LOCATION	HYDRAULIC VALVE CIRCUITS		FUNCTION
				PRESSUE PORT	TANK PORT	
1-GREEN	UP	RED/BLACK, ORANGE/BLACK, GREEN**	5, 6, 10	C3	C7	MAIN WINGS - TRANSPORT
	CENTER	OFF	NA	NA	NA	OFF
	DOWN	RED/BLACK, ORANGE/BLACK, GREEN**, BLACK/WHITE	5, 6, 10, 9	C7	C3	MAIN WINGS - FIELD
2-YELLOW	UP	WHITE, ORANGE, GREEN**	3, 2, 10	C2	C6	LATCHES - TRANSPORT
	CENTER	OFF	NA	NA	NA	OFF
	DOWN	WHITE, ORANGE, GREEN**, BLACK/WHITE	3, 2, 10, 9	C6	C2	LATCHES - FIELD
3-GREY	UP	BLUE, WHITE/BLACK, GREEN**	8, 7, 10	C4	C8	FLIP WINGS - TRANSPORT
	CENTER	OFF	NA	NA	NA	OFF
	DOWN	BLUE, WHITE/BLACK, GREEN**, BLACK/WHITE	8, 7, 10, 9	C8	C4	FLIP WINGS - FIELD

\*\*Green wire fires dump valve for open center hydraulic setup. Valve is setup closed center from Fasse (valve manufacturer).

The SV38-38 line body valves only work if both limit switches are detecting metal.

Valve is setup as closed center.

#### Ground Wires

- Black11
- Blue/Black 4
- Red 1

#### Constant Power

- Green/Black12



ILLUSTRATED PARTS LIST (CONT'D)

Fold Hydraulic System

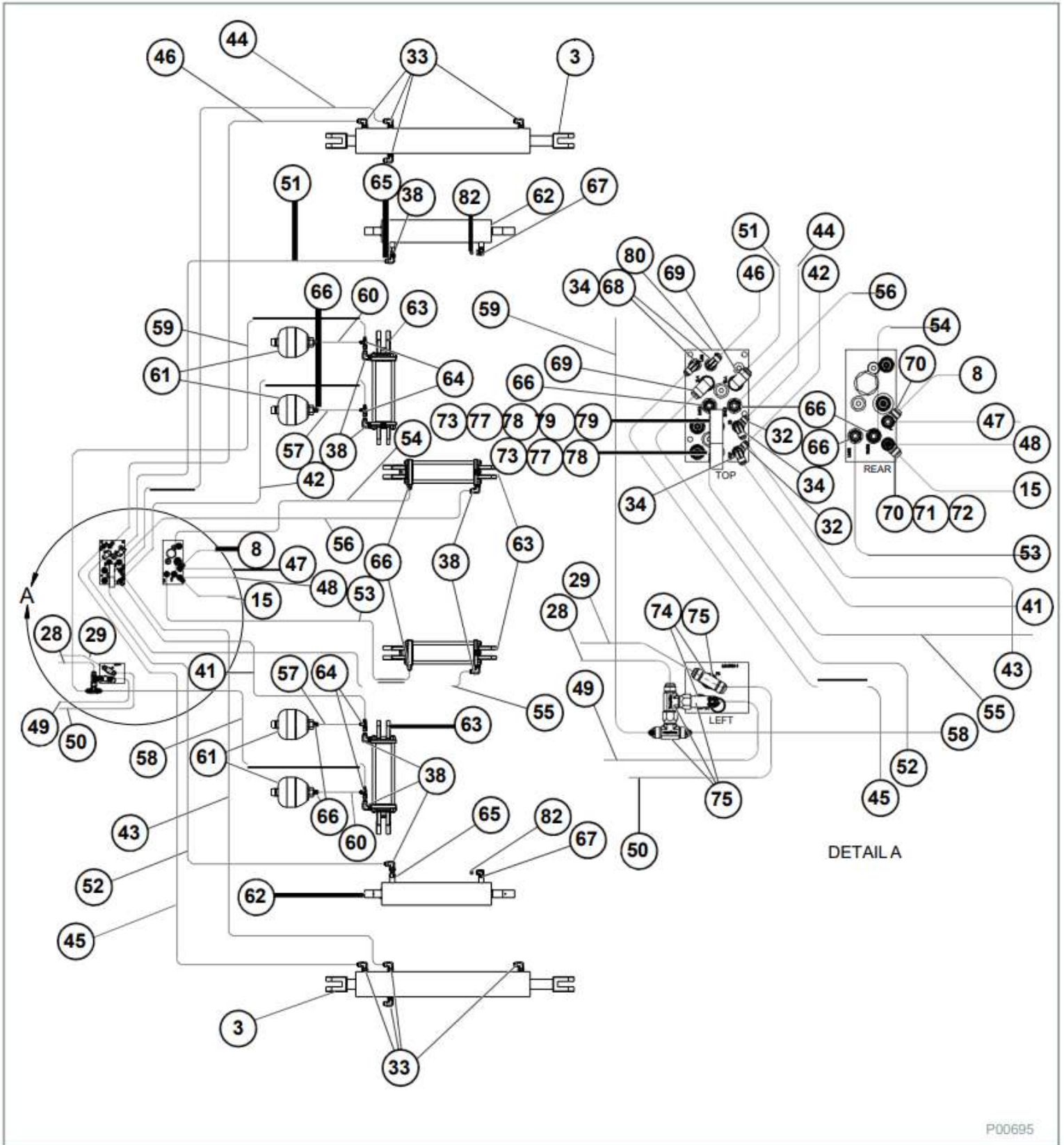

P00695

## ILLUSTRATED PARTS LIST (CONT'D)

### Fold Hydraulic System (Cont'd)

ITEM NO.	PART NO.	DESCRIPTION	QTY.
1*	630039	FOLD SYSTEM BLOCK AND CAB BOX	1
2*	620023	FOLDING GAGE WHEEL CYLINDER	4
3	620027	FLIP WING KICK/FOLD CYLINDER	2
4*	600050-6-ZN	HYDRAULIC HOSE 3/8 X 354 IN (8992 MM)	1
5*	600085-3-ZN	HYDRAULIC HOSE 1/4 X 220 IN (5588 MM)	1
6*	600085-3-ZN	HYDRAULIC HOSE 1/4 X 220 IN (5588 MM)	1
7*	600050-7A-ZN	HYDRAULIC HOSE 3/8 X 339 IN (8611 MM)	1
8	600050-23-ZN	HYDRAULIC HOSE 1/2 X 43 IN (1092 MM)	1
9*	600050-2A-ZN	HYDRAULIC HOSE 1/2 X 98 IN (2489 MM)	1
10*	600050-9A-ZN	HYDRAULIC HOSE 3/8 X 12.5 IN (318 MM)	1
11*	620046	MAIN WING FOLD CYLINDER	2
12*	610026	T-FITTING #4 FJIX X #4 MJIC X #4 MJIC	4
13*	600085-2-ZN	HYDRAULIC HOSE 1/4 X 24 IN (610 MM)	1
14*	600085-4-ZN	HYDRAULIC HOSE 1/4 X 208 IN (5283 MM)	1
15	600050-23-ZN	HYDRAULIC HOSE 1/2 X 43 IN (1092 MM)	1
16*	620026	WING LATCH CYLINDER	2
17*	500067	COUNTERBALANCE VALVE	2
18*	600050-1A-ZN	HYDRAULIC HOSE 1/2 X 88 IN (2235 MM)	1
19*	600085-4-ZN	HYDRAULIC HOSE 1/4 X 208 IN (5283 MM)	1
20*	600050-11A-ZN	HYDRAULIC HOSE 3/8 X 91 IN (2311 MM)	1
21*	600050-24A-ZN	HYDRAULIC HOSE 3/8 X 137 IN (3480 MM)	1
22*	600050-12A-ZN	HYDRAULIC HOSE 3/8 X 100 IN (2540 MM)	1
23*	600050-4A-ZN	HYDRAULIC HOSE 3/8 X 133 IN (3378 MM)	1
24*	600050-13A-ZN	HYDRAULIC HOSE 3/8 X 309 IN (7849 MM)	1
25*	600050-14-ZN	HYDRAULIC HOSE 3/8 X 305 IN (7747 MM)	1
26*	600050-17A-ZN	HYDRAULIC HOSE 1/2 X 52 IN (1321 MM)	1
27*	600050-18A-ZN	HYDRAULIC HOSE 1/2 X 64 IN (1626 MM)	1
28	600085-1-ZN	HYDRAULIC HOSE 1/2 X 20 IN (508 MM)	1
29	600085-1-ZN	HYDRAULIC HOSE 1/2 X 20 IN (508 MM)	1
30*	610029	FITTING 90° #8 MORB X #4 MJIC	8
31*	610027	T-FITTING #6 FJIX X #6 MJIC X #6 MJIC	4
32	610074	T-FITTING #6 MORB X #6 MJIC X #6 MJIC	6
33	610030	FITTING 90° #8 MORB X #6 MJIC	14
34	610023	FITTING 90° #6 FJIX X #6 MJIC	8
35*	610030	T-FITTING #8 MORB X #8 MJIC X #8 MJIC	2
36*	610024	FITTING 90° #8 FJIX X #8 MJIC	11
37*	6804-8-8-8	T-FITTING #8 MORB X #8 MJIC X #8 MJIC	2
38	610097	FITTING 90O #8 MORB X #8 MJIC	12
39*	610027	T-FITTING #6 FJIX X #6 MJIC X #6 MJIC	2
40*	6807-08-08	FITTING 90O #8 MORB X #8 MORB	2

\*-Not shown. See *Lift And Down Pressure System* on Pages 160 - 163.

ILLUSTRATED PARTS LIST (CONT'D)

Fold Hydraulic System (Cont'd)

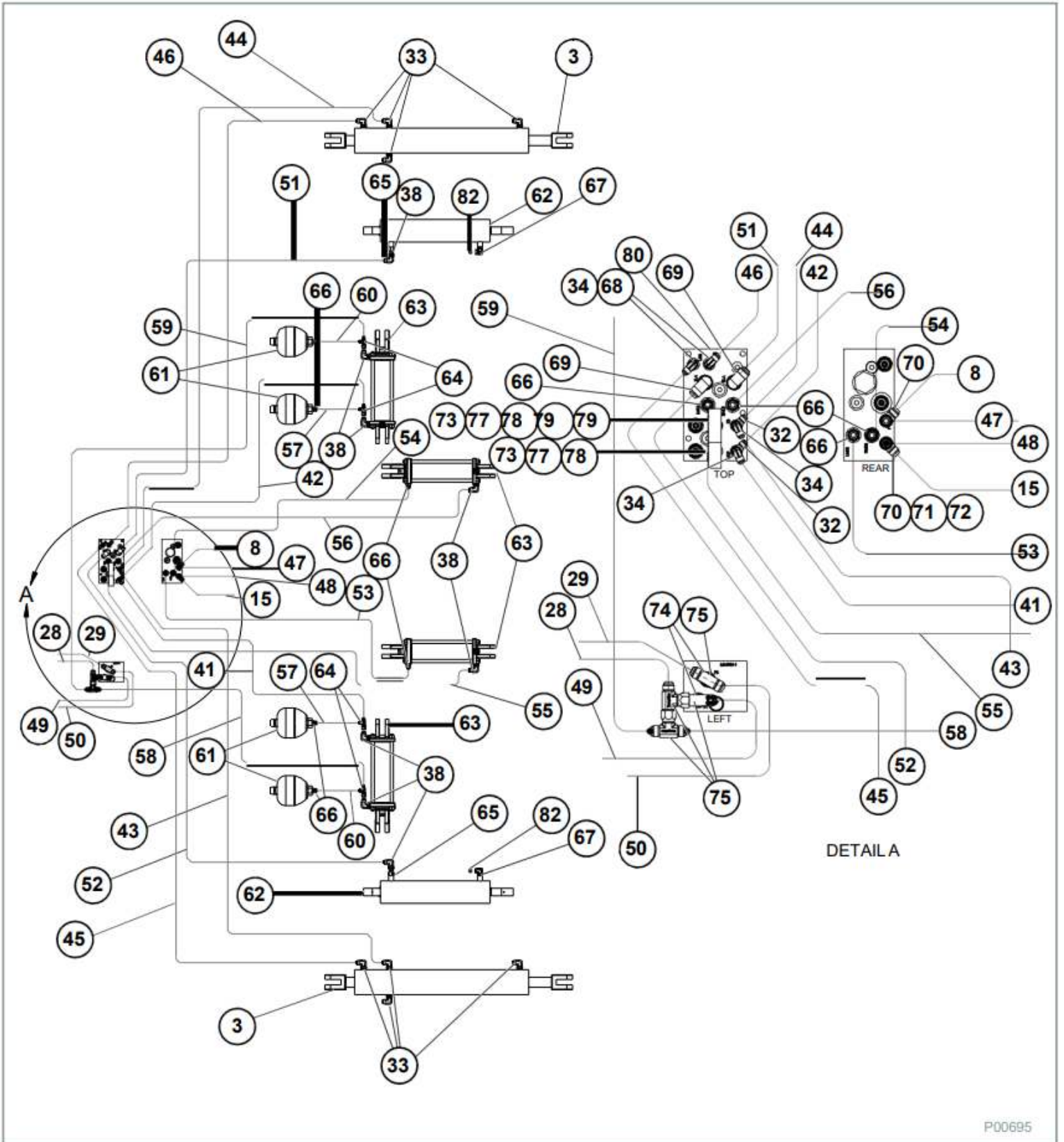

P00695

**ILLUSTRATED PARTS LIST (CONT'D)**
**Fold Hydraulic System (Cont'd)**

ITEM NO.	PART NO.	DESCRIPTION	QTY.
41	600050-10A-ZN	HYDRAULIC HOSE 3/8 X 63 IN (1600 MM)	1
42	600050-3-ZN	HYDRAULIC HOSE 3/8 X 130 IN (3302 MM)	1
43	600050-15-ZN	HYDRAULIC HOSE 3/8 X 281 IN (7137 MM)	1
44	600050-5-ZN	HYDRAULIC HOSE 3/8 X 350 IN (8890 MM)	1
45	600050-16-ZN	HYDRAULIC HOSE 3/8 X 282 IN (7163 MM)	1
46	600050-8-ZN	HYDRAULIC HOSE 3/8 X 348 IN (8839 MM)	1
47	600050-19-ZN	HYDRAULIC HOSE 1/2 X 300 IN (7620 MM)	1
48	600050-19-ZN	HYDRAULIC HOSE 1/2 X 300 IN (7620 MM)	1
49	600050-20-ZN	HYDRAULIC HOSE 5/8 X 300 IN (7620 MM)	1
50	600050-20-ZN	HYDRAULIC HOSE 5/8 X 300 IN (7620 MM)	1
51	600050-21-ZN	HYDRAULIC HOSE 5/8 X 370 IN (9398 MM)	1
52	600050-22-ZN	HYDRAULIC HOSE 5/8 X 298 IN (7569 MM)	1
53	600050-27A-ZN	HYDRAULIC HOSE 1/2 X 68 IN (1727 MM)	1
54	600050-28A-ZN	HYDRAULIC HOSE 1/2 X 134 IN (3404 MM)	1
55	600050-25A-ZN	HYDRAULIC HOSE 1/2 X 47 IN (1194 MM)	1
56	600050-26A-ZN	HYDRAULIC HOSE 1/2 X 152 IN (3861 MM)	1
57	600050-29-ZN	HYDRAULIC HOSE 3/8 X 18 IN (457 MM)	1
58	600050-30-ZN	HYDRAULIC HOSE 1/2 X 78 IN (1981 MM)	1
59	600050-31-ZN	HYDRAULIC HOSE 1/2 X 145 IN (3683 MM)	1
60	600050-32-ZN	HYDRAULIC HOSE 1/2 X 36 IN (914 MM)	1
61	630020	ACCUMULATOR	4
62	620089	LIFT ASSIST CYLINDER	2
63	620073	MAIN LIFT AND DOWN PRESSURE CYLINDER	4
64	610053	T-FITTING #8 FJIX X #8 MJIC X #8 MJIC	4
65	610095	FITTING 0.090 IN. ONE WAY ORIFICE	2
66	610013	FITTING STRAIGHT #8 MORB X #8 MJIC	10
67	610035	FITTING #8 MORB X #6 FORB 90°	2
68	610010	FITTING STRAIGHT #6 MORB X #6 MJIC	2
69	610102	FITTING 90° #10 MORB X #10 MJIC	2
70	610130	T-FITTING #6 MORB X #8 MJIC X #8 MJIC	2
71	610068	FITTING #8 FJIX X #8 FJIX SWIVEL UNION	1
72	630043	FITTING #8 MJIC X #8 MJIC INLINE CHECK VALVE	3
73	790052	GAGE	2
74	610106	FITTING STRAIGHT #10 MORB X #10 MJIC	2
75	610120	T-FITTING #10 MJIC X #10 MJIC X #10 FJIX SWIVEL BRANCH	4
76*	6510-08-06	FITTING #6 FJIX X #8 FJIX ADAPTER	2
77	610008	FITTING STRAIGHT #6 MORB X #4 MJIC	2
78	610025	FITTING STRAIGHT #4 FJIX X 1/4 FNPT	2
79	610129	FITTING STRAIGHT #6 MORB X #6 FORB	2
80	15850	LIFT AND DOWN PRESSURE BLOCK	1
81*	610072	FITTING #8 TO #6 JIC REDUCER	2
82	610036	FITTING #6 MORB BREATHER	2

\*-Not shown. See *Lift And Down Pressure System on Pages 160 - 163.*

ILLUSTRATED PARTS LIST (CONT'D)

Lift And Down Pressure System

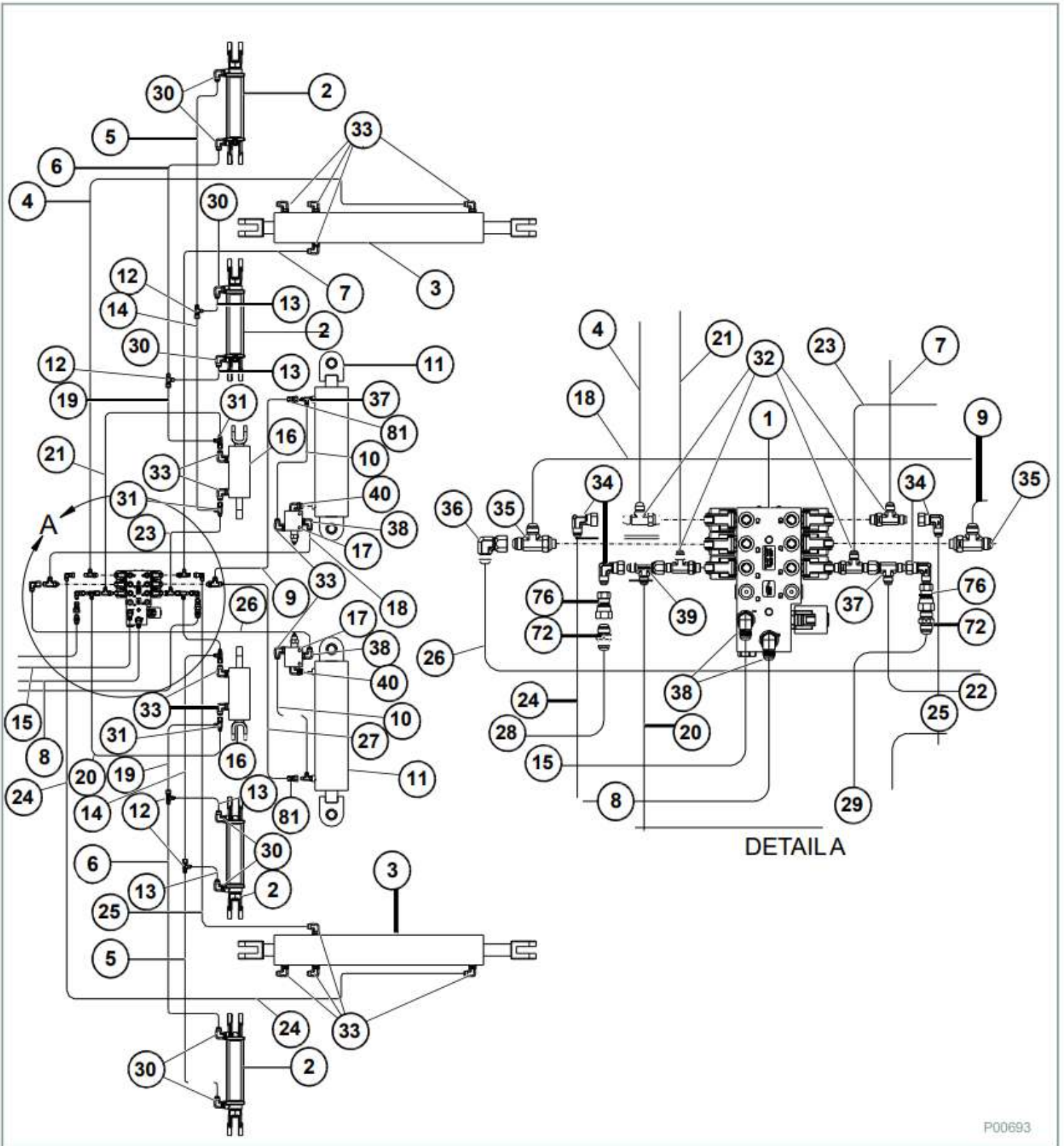

P00693



**ILLUSTRATED PARTS LIST (CONT'D)**
**Lift And Down Pressure System (Cont'd)**

ITEM NO.	PART NO.	DESCRIPTION	QTY.
1	630039	FOLD SYSTEM BLOCK	1
2	620023	FOLDING GAGE WHEEL CYLINDER	4
3	620027	FLIP WING KICK/FOLD CYLINDER	2
4	600050-6-ZN	HYDRAULIC HOSE 3/8 X 354 IN (8992 MM)	1
5	600085-3-ZN	HYDRAULIC HOSE 1/4 X 220 IN (5588 MM)	1
6	600085-3-ZN	HYDRAULIC HOSE 1/4 X 220 IN (5588 MM)	1
7	600050-7A-ZN	HYDRAULIC HOSE 3/8 X 339 IN (8611 MM)	1
8	600050-23-ZN	HYDRAULIC HOSE 1/2 X 43 IN (1092 MM)	1
9	600050-2A-ZN	HYDRAULIC HOSE 1/2 X 98 IN (2489 MM)	1
10	600050-9A-ZN	HYDRAULIC HOSE 3/8 X 12.5 IN (318 MM)	1
11	620046	MAIN WING FOLD CYLINDER	2
12	610026	T-FITTING #4 FJIX X #4 MJIC X #4 MJIC	4
13	600085-2-ZN	HYDRAULIC HOSE 1/4 X 24 IN (610 MM)	1
14	600085-4-ZN	HYDRAULIC HOSE 1/4 X 208 IN (5283 MM)	1
15	600050-23-ZN	HYDRAULIC HOSE 1/2 X 43 IN (1092 MM)	1
16	620026	WING LATCH CYLINDER	2
17	500067	COUNTERBALANCE VALVE	2
18	600050-1A-ZN	HYDRAULIC HOSE 1/2 X 88 IN (2235 MM)	1
19	600085-4-ZN	HYDRAULIC HOSE 1/4 X 208 IN (5283 MM)	1
20	600050-11A-ZN	HYDRAULIC HOSE 3/8 X 91 IN (2311 MM)	1
21	600050-24A-ZN	HYDRAULIC HOSE 3/8 X 137 IN (3480 MM)	1
22	600050-12A-ZN	HYDRAULIC HOSE 3/8 X 100 IN (2540 MM)	1
23	600050-4A-ZN	HYDRAULIC HOSE 3/8 X 133 IN (3378 MM)	1
24	600050-13A-ZN	HYDRAULIC HOSE 3/8 X 309 IN (7849 MM)	1
25	600050-14-ZN	HYDRAULIC HOSE 3/8 X 305 IN (7747 MM)	1
26	600050-17A-ZN	HYDRAULIC HOSE 1/2 X 52 IN (1321 MM)	1
27	600050-18A-ZN	HYDRAULIC HOSE 1/2 X 64 IN (1626 MM)	1
28	600085-1-ZN	HYDRAULIC HOSE 1/2 X 20 IN (508 MM)	1
29	600085-1-ZN	HYDRAULIC HOSE 1/2 X 20 IN (508 MM)	1
30	610029	FITTING 90° #8 MORB X #4 MJIC	8
31	610027	T-FITTING #6 FJIX X #6 MJIC X #6 MJIC	4
32	610074	T-FITTING #6 MORB X #6 MJIC X #6 MJIC	6
33	610030	FITTING 90° #8 MORB X #6 MJIC	14
34	610023	FITTING 90° #6 FJIX X #6 MJIC	8
35	610030	T-FITTING #8 MORB X #8 MJIC X #8 MJIC	2
36	610024	FITTING 90° #8 FJIX X #8 MJIC	11
37	6804-8-8-8	T-FITTING #8 MORB X #8 MJIC X #8 MJIC	2
38	610097	FITTING 90O #8 MORB X #8 MJIC	12
39	610027	T-FITTING #6 FJIX X #6 MJIC X #6 MJIC	2
40	6807-08-08	FITTING 90O #8 MORB X #8 MORB	2

ILLUSTRATED PARTS LIST (CONT'D)

Lift And Down Pressure System (Cont'd)

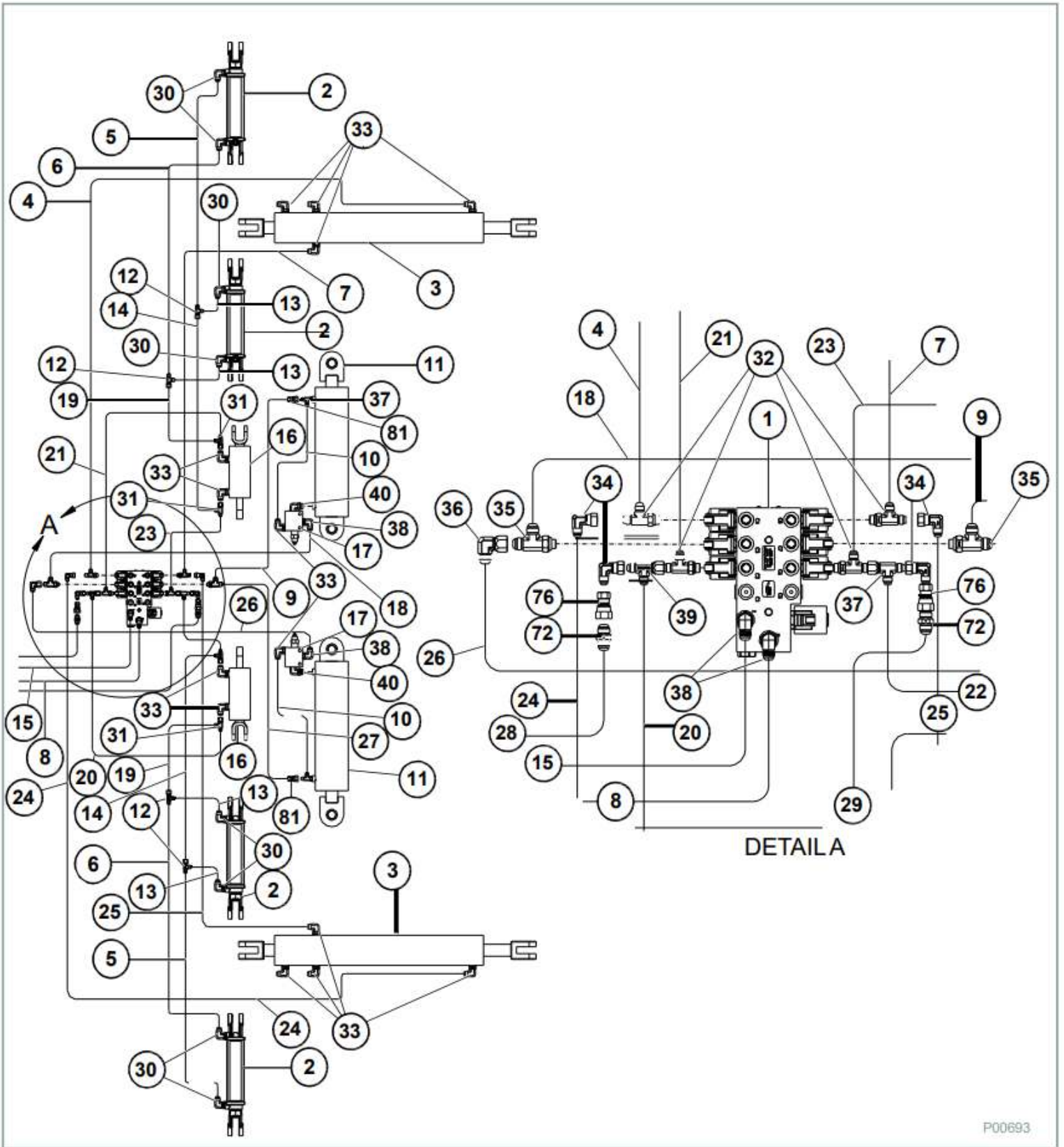

**ILLUSTRATED PARTS LIST (CONT'D)**
**Lift And Down Pressure System (Cont'd)**

ITEM NO.	PART NO.	DESCRIPTION	QTY.
41*	600050-10A-ZN	HYDRAULIC HOSE 3/8 X 63 IN (1600 MM)	1
42*	600050-3-ZN	HYDRAULIC HOSE 3/8 X 130 IN (3302 MM)	1
43*	600050-15-ZN	HYDRAULIC HOSE 3/8 X 281 IN (7137 MM)	1
44*	600050-5-ZN	HYDRAULIC HOSE 3/8 X 350 IN (8890 MM)	1
45*	600050-16-ZN	HYDRAULIC HOSE 3/8 X 282 IN (7163 MM)	1
46*	600050-8-ZN	HYDRAULIC HOSE 3/8 X 348 IN (8839 MM)	1
47*	600050-19-ZN	HYDRAULIC HOSE 1/2 X 300 IN (7620 MM)	1
48*	600050-19-ZN	HYDRAULIC HOSE 1/2 X 300 IN (7620 MM)	1
49*	600050-20-ZN	HYDRAULIC HOSE 5/8 X 300 IN (7620 MM)	1
50*	600050-20-ZN	HYDRAULIC HOSE 5/8 X 300 IN (7620 MM)	1
51*	600050-21-ZN	HYDRAULIC HOSE 5/8 X 370 IN (9398 MM)	1
52*	600050-22-ZN	HYDRAULIC HOSE 5/8 X 298 IN (7569 MM)	1
53*	600050-27A-ZN	HYDRAULIC HOSE 1/2 X 68 IN (1727 MM)	1
54*	600050-28A-ZN	HYDRAULIC HOSE 1/2 X 134 IN (3404 MM)	1
55*	600050-25A-ZN	HYDRAULIC HOSE 1/2 X 47 IN (1194 MM)	1
56*	600050-26A-ZN	HYDRAULIC HOSE 1/2 X 152 IN (3861 MM)	1
57*	600050-29-ZN	HYDRAULIC HOSE 3/8 X 18 IN (457 MM)	1
58*	600050-30-ZN	HYDRAULIC HOSE 1/2 X 78 IN (1981 MM)	1
59*	600050-31-ZN	HYDRAULIC HOSE 1/2 X 145 IN (3683 MM)	1
60*	600050-32-ZN	HYDRAULIC HOSE 1/2 X 36 IN (914 MM)	1
61*	630020	ACCUMULATOR	4
62*	620089	LIFT ASSIST CYLINDER	2
63*	620073	MAIN LIFT AND DOWN PRESSURE CYLINDER	4
64*	610053	T-FITTING #8 FJIX X #8 MJIC X #8 MJIC	4
65*	610095	FITTING 0.090 IN. ONE WAY ORIFICE	2
66*	610013	FITTING STRAIGHT #8 MORB X #8 MJIC	10
67*	610035	FITTING #8 MORB X #6 FORB 90°	2
68*	610010	FITTING STRAIGHT #6 MORB X #6 MJIC	2
69*	610102	FITTING 90° #10 MORB X #10 MJIC	2
70*	610130	T-FITTING #6 MORB X #8 MJIC X #8 MJIC	2
71*	610068	FITTING #8 FJIX X #8 FJIX SWIVEL UNION	1
72	630043	FITTING #8 MJIC X #8 MJIC INLINE CHECK VALVE	3
73*	790052	GAGE	2
74*	610106	FITTING STRAIGHT #10 MORB X #10 MJIC	2
75*	610120	T-FITTING #10 MJIC X #10 MJIC X #10 FJIX SWIVEL BRANCH	4
76	6510-08-06	FITTING #6 FJIX X #8 FJIX ADAPTER	2
77*	610008	FITTING STRAIGHT #6 MORB X #4 MJIC	2
78*	610025	FITTING STRAIGHT #4 FJIX X 1/4 FNPT	2
79*	610129	FITTING STRAIGHT #6 MORB X #6 FORB	2
80*	15850	LIFT AND DOWN PRESSURE BLOCK	1
81	610072	FITTING #8 TO #6 JIC REDUCER	2
82*	610036	FITTING #6 MORB BREATHER	2

\* - Not shown. See *Fold Hydraulic System* on Pages 156 - 159.

ILLUSTRATED PARTS LIST (CONT'D)

Lift And Down Pressure Control Valve

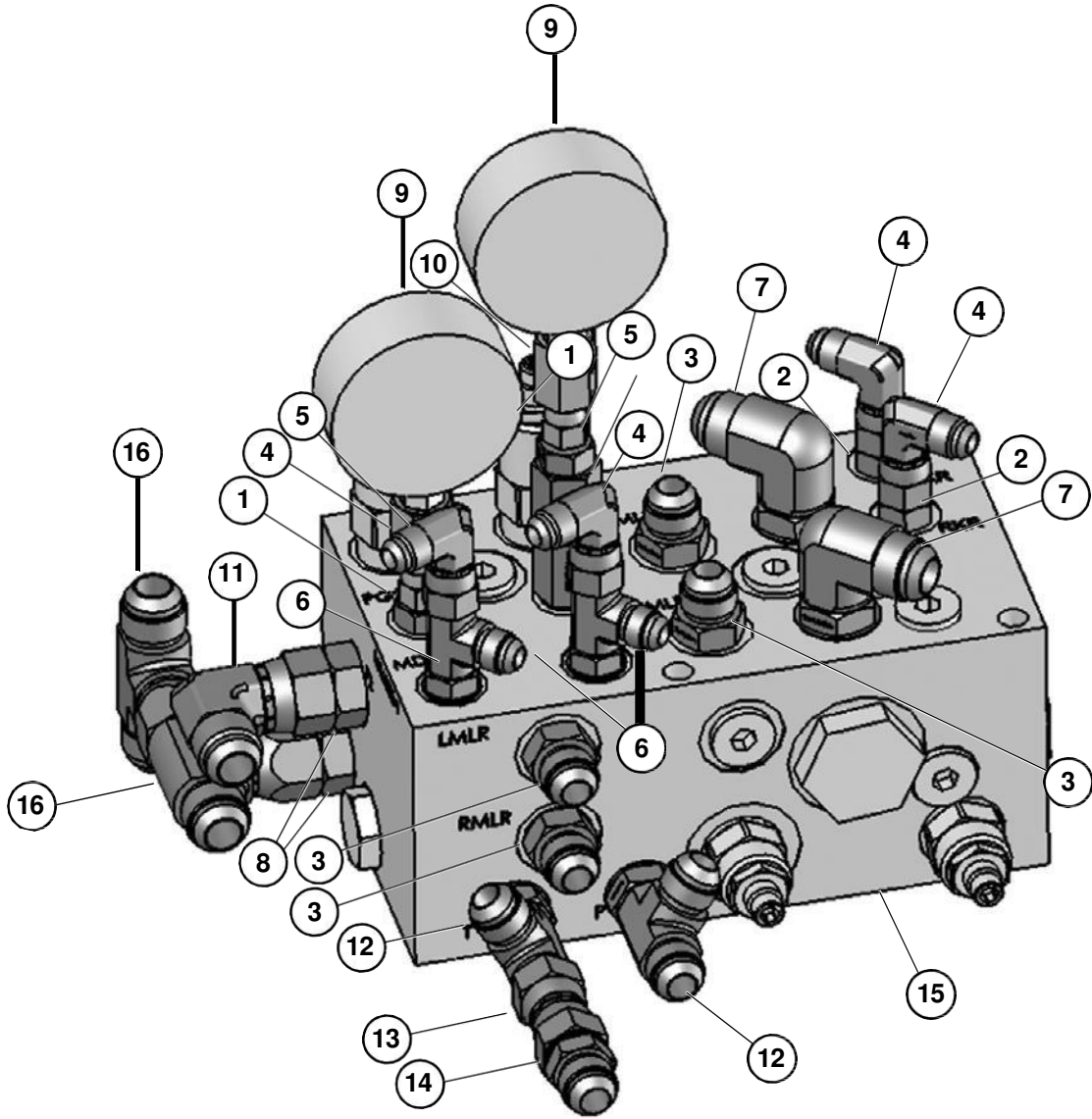

P00550

## ILLUSTRATED PARTS LIST (CONT'D)

### Lift And Down Pressure Control Valve (Cont'd)

ITEM NO.	PART NO.	DESCRIPTION	QTY.
1	610008	#4 JIC TO #6 O RING 6400-04-06	2
2	610010	ADAPTER 6400-06-06	2
3	610013	ADAPTER 6400-08-08	4
4	610023	JIC #6 90 DEG 6500-6 90°	4
5	610025	JIC #4 FEMALE SWIVEL TO 1-4 IN. PIPE 6500-4-4 1/4 IN. PIPE	2
6	610074	O-RING RUN TEE #6 6804-06-08-06 TEE	2
7	610102	JIC #10 TO O-RING #10 ELBOW 90° 6801-10-10 90°	2
8	610106	ADAPTER 6801-10-10	2
9	790052	PRESSURE GAUGE 3000 PSI	2
10	610129	#6 O-RING TO #6 O-RING EXTENDER 6410L-06-06-1.5	2
11	610131	#10 JIC SWIVEL ELBOW 90 DEG. 6500-10-10	1
12	610130	#8 JIC TO #6 O-RING RUN TEE 6804-08-06-08	2
13	610068	JIC #8 SWIVEL UNION 6510-08-08	1
14	630043	INLINE CHECK VALVE	1
15	630039	90' LIFT ASSIST BLOCK	1
16	610120	#10 JIC SWIVEL BRANCH TEE 6600-10-10-10	2

**ILLUSTRATED PARTS LIST (CONT'D)**

**Fold Valve With Fittings**

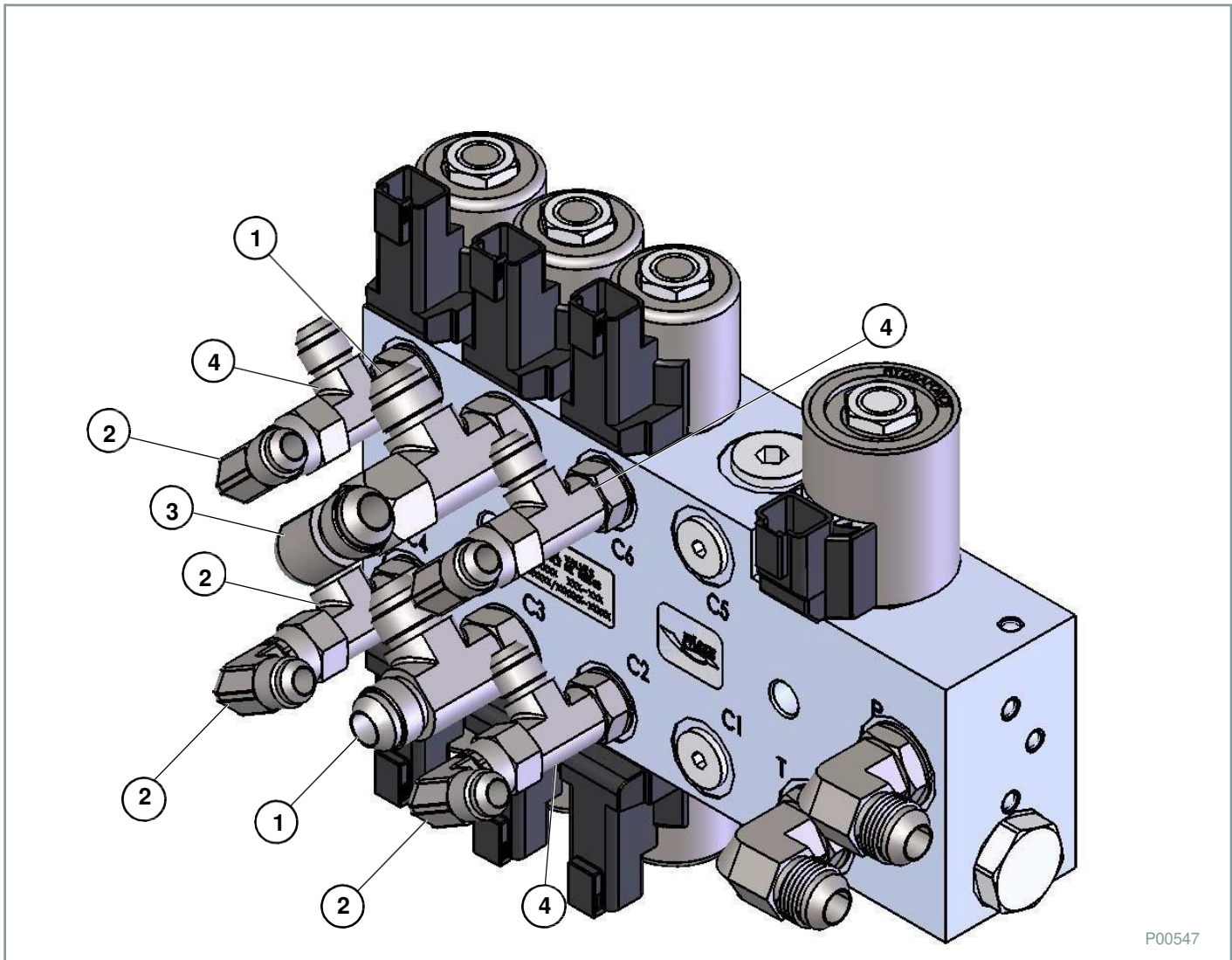

P00547

ITEM NO.	PART NO.	DESCRIPTION	QTY.
1	610130	RUN TEE ADAPTER 6804-08-06-08	2
2	610023	JIC #6 90 DEG 6500-06	4
3	610024	JIC #8 90 DEG 6500-08	1
4	610074	O-RING RUN TEE #6 6804-06-06-06	4
5	630039 FOLD VALVE	90° FOLD VALVE	1

## ILLUSTRATED PARTS LIST (CONT'D)

### Hydraulic Hose Description

HYD. HOSE LOCATION *	PART NO.	SIZE	FITTING **		LENGTH	HOSE FUNCTION	POSITION
LDP#41	600050-10A-ZN	3/8 IN.	ST,	90°	63 IN. (1600 MM)	LEFT DOWN PRESSURE (BASE)	MVB-MDP
LDP#42	600050-3-ZN	3/8 IN.	ST,	ST,	130 IN. (3302 MM)	RIGHT DOWN PRESSURE (BASE)	MVB-MDP
FS#20	600050-11A-ZN	3/8 IN.	ST,	ST,	91 IN. (2311 MM)	LEFT LATCH (ROD)	FB-C2
FS#21	600050-24A-ZN	3/8 IN.	ST,	ST,	137 IN. (3480 MM)	RIGHT LATCH (ROD)	FB-C2
FS#22	600050-12A-ZN	3/8 IN.	ST,	ST,	100 IN. (2540 MM)	LEFT LATCH (BASE)	FB-C6
FS#23	600050-4A-ZN	3/8 IN.	ST,	ST,	133 IN. (3378 MM)	RIGHT LATCH (BASE)	FB-C6
FS#24	600050-13A-ZN	3/8 IN.	ST,	ST,	309 IN. (7849 MM)	LEFT FLIP FOLD (ROD)	FB-C4
FS#4	600050-6-ZN	3/8 IN.	ST,	ST,	354 IN. (8992 MM)	RIGHT FLIP FOLD (ROD)	FB-C4
FS#25	600050-14-ZN	3/8 IN.	ST,	ST,	305 IN. (7747 MM)	LEFT FLIP FOLD (BASE)	FB-C8
FS#7	600050-7A-ZN	3/8 IN.	ST,	ST,	339 IN. (8611 MM)	RIGHT FLIP FOLD (BASE)	FB-C8
LDP#43	600050-15-ZN	3/8 IN.	ST,	ST,	281 IN. (7137 MM)	LEFT KICK (BASE)	MVB-KB
LDP#44	600050-5-ZN	3/8 IN.	ST,	ST,	350 IN. (8890 MM)	RIGHT KICK (BASE)	MVB-KB
LDP#45	600050-16-ZN	3/8 IN.	ST,	ST,	282 IN. (7163 MM)	LEFT KICK (ROD)	MVB-LKR
LDP#46	600050-8-ZN	3/8 IN.	ST,	ST,	348 IN. (8839 MM)	RIGHT KICK (ROD)	MVB-RKR
FS#26	600050-17A-ZN	1/2 IN.	ST,	90°	52 IN. (1321 MM)	LEFT MAIN FOLD (BASE) CB-2	FB-C3
FS#18	600050-1A-ZN	1/2 IN.	ST,	ST,	88 IN. (2235 MM)	RIGHT MAIN FOLD (BASE) CB-2	FB-C3
FS#27	600050-18A-ZN	1/2 IN.	ST,	90°	64 IN. (1626 MM)	LEFT MAIN FOLD (ROD)	FB-C7
FS#9	600050-2A-ZN	1/2 IN.	ST,	90°	98 IN. (2489 MM)	RIGHT MAIN FOLD (ROD)	FB-C7
LDP#47	600050-19-ZN	1/2 IN.	PO	ST,	300 IN. (7620 MM)	1/2 IN. TRACTOR HOSE	MVB-P
LDP#48	600050-19-ZN	1/2 IN.	PO	ST,	300 IN. (7620 MM)	1/2 IN. TRACTOR HOSE	MVB-T
LDP#49	600050-20-ZN	5/8 IN.	PO	ST,	300 IN. (7620 MM)	5/8 IN. TRACTOR HOSE	MVB-P1
LDP#50	600050-20-ZN	5/8 IN.	PO	ST,	300 IN. (7620 MM)	5/8 IN. TRACTOR HOSE	MVB-P2

#### \* - Hydraulic Hose Location

FS - Fold Hydraulic System Page 156 - 159

LPD - Lift And Down Pressure System Page 160 - 163

#### \* - Fitting Type

ST. - Straight Fitting

90° - 90 Degree Fitting

PO - Pioneer OR Fitting

#### \* - Position

FB - Fold Block

MVB - Main Valve Block

RKR - Outer Wing Kick Rod

RMLB - Right Main Lift Base

LMLB - Left Main Lift Base

RMLR - Right Main Lift Rod

LMLR - Left Main Lift Rod

ACC - Accumulator

RLA - Right Lift Assist

LLA - Left Lift Assist

MDP - Main Down Pressure

KB - Outer Wing Kick Base

## ILLUSTRATED PARTS LIST (CONT'D)

### Hydraulic Hose Description (Cont'd)

HYD. HOSE LOCATION*	PART NO.	SIZE	FITTING**	LENGTH	HOSE FUNCTION	POSITION	
LDP#51	600050-21-ZN	5/8 IN.	1/2 IN. ST.	ST.	370 IN. (9398 MM)	RH LIFT ASSIST BASE	MVB-RLA
LDP#52	600050-22-ZN	5/8 IN.	1/2 IN. ST.	ST.	298 IN. (7569 MM)	LH LIFT ASSIST BASE	MVB-LLA
FS#15, LDP#15	600050-23-ZN	1/2 IN.	ST.	90°	43 IN. (1092 MM)	MVB-T	FB-T
FS#8, LDP#8	600050-23-ZN	1/2 IN.	ST.	90°	43 IN. (1092 MM)	MVB-P	FB-P
LDP#55	600050-25A-ZN	1/2 IN.	ST.	90°	47 IN. (1194 MM)	LEFT MAIN LIFT (BASE)	MVB-LMLB
LDP#56	600050-26A-ZN	1/2 IN.	ST.	90°	152 IN. (3861 MM)	RIGHT MAIN LIFT (BASE)	MVB-RMLB
LDP#53	600050-27A-ZN	1/2 IN.	90°	ST.	68 IN. (1727 MM)	LEFT MAIN LIFT (ROD)	MVB-LMLR
LDP#54	600050-28A-ZN	1/2 IN.	ST.	90°	134 IN. (3404 MM)	RIGHT MAIN LIFT (ROD)	MVB-RMLR
LDP#57	600050-29-ZN	3/8 IN.	ST.	90°	18 IN. 457 MM)	MAIN DOWN PRESSURE (BASE)	ACC
FS#10	600050-9A-ZN	3/8 IN.	ST.	ST.	12.5 IN. 318 MM)	MAIN FOLD CB-3	MAIN FOLD ROD
	600054-1-ZN	1/2 IN.	PO	ST.	163 IN. (4140 MM)	TRACTOR PRESSURE	OVERSPEED VALVE - 1
	600054-2A-ZN	1/2 IN.	ST.	90°	85 IN. (2159 MM)	OVERSPEED VALVE-2	PUMP INLET
	600054-3-ZN	5/8 IN.	PO	ST.	250 IN. (6350 MM)	PUMP OUTLET	TRACTOR TANK
LDP#58	600050-30-ZN	1/2 IN.	5/8 IN. 90°	ST.	78 IN. (1981 MM)	LEFT MAIN DOWN PRESSURE (ROD)	MVB-P1
LDP#59	600050-31-ZN	1/2 IN.	5/8 IN. 90°	ST.	145 IN. (3683 MM)	RIGHT MAIN DOWN PRESSURE (ROD)	MVB-P1
LDP#60	600050-32-ZN	1/2 IN.	ST.	90°	36 IN. (914 MM)	MAIN DOWN PRESSURE (ROD)	ACC
FS#28, LDP#28	600085-1-ZN	1/2 IN.	ST.	5/8 IN. ST.	20 IN. (508 MM)	FB-C2	MVB-P1
FS#29, LDP#29	600085-1-ZN	1/2 IN.	ST.	5/8 IN. ST.	20 IN. (508 MM)	FB-C6	MVB-P2
FS#13	600085-2-ZN	1/4 IN.	ST.	ST.	24 IN. (610 MM)	MAIN FOLDING GAUGE WHEEL CYL	FOLDING GAUGE WHEEL FEED LINES
FS#6	600085-3-ZN	1/4 IN.	ST.	ST.	220 IN. (5588 MM)	INNER GAUGE WHEEL (BASE)	OUTER GAUGE WHEEL (BASE)
FS#5	600085-3-ZN	1/4 IN.	ST.	ST.	220 IN. (5588 MM)	INNER GAUGE WHEEL (ROD)	OUTER GAUGE WHEEL (ROD)
FS#14	600085-4-ZN	1/4 IN.	ST.	ST.	208 IN. (5283 MM)	INNER GAUGE WHEEL (ROD)	LATCH CYL (BASE)
FS#19	600085-4-ZN	1/4 IN.	ST.	ST.	208 IN. (5283 MM)	INNER GAUGE WHEEL (BASE)	LATCH CYL (ROD)



## ILLUSTRATED PARTS LIST (CONT'D)

### Hydraulic Hose Description (Cont'd)

#### \* - Hydraulic Hose Location

FS - *Fold Hydraulic System Page 156 - 159*

LPD - *Lift And Down Pressure System Page 160 - 163*

#### \* - Fitting Type

ST. - Straight Fitting

90° - 90 Degree Fitting

PO - Pioneer OR Fitting

#### \* - Position

FB - Fold Block

MVB - Main Valve Block

RKR - Outer Wing Kick Rod

RMLB - Right Main Lift Base

LMLB - Left Main Lift Base

RMLR - Right Main Lift Rod

LMLR - Left Main Lift Rod

ACC - Accumulator

RLA - Right Lift Assist

MDP - Main Down Pressure

KB - Outer Wing Kick Base

LLA - Left Lift Assist

**ILLUSTRATED PARTS LIST (CONT'D)**

**Pump Hydraulic System**

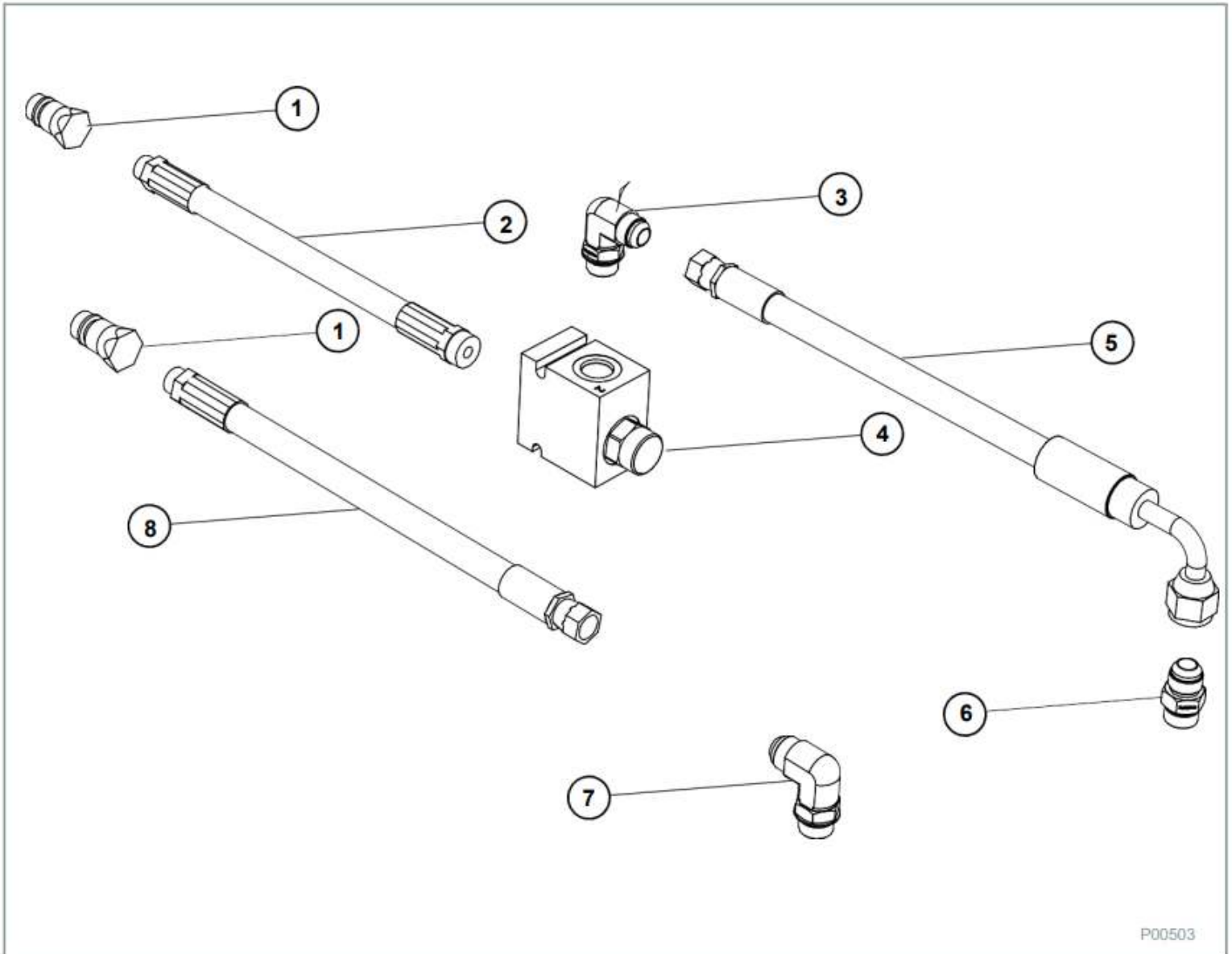

P00503

ITEM NO.	PART NO.	DESCRIPTION	QTY.
1	520048	HOSE TIP	2
2	PA600054-1	HOSE PRESSURE TO VALVE	1
3	610086	HYDRAULIC FITTING 6801-8-10	1
4	610099	PC VALVE 13 GPM	1
5	PA600054-2	HOSE PRESSURE TO PUMP	1
6	610106	HYDRAULIC FITTING 6400-10-10	1
7	610102	HYDRAULIC FITTING 6801-10-10	1
8	PA600054-3	HOSE PUMP RETURN	1

## ILLUSTRATED PARTS LIST (CONT'D)

### Toolbox Carrier

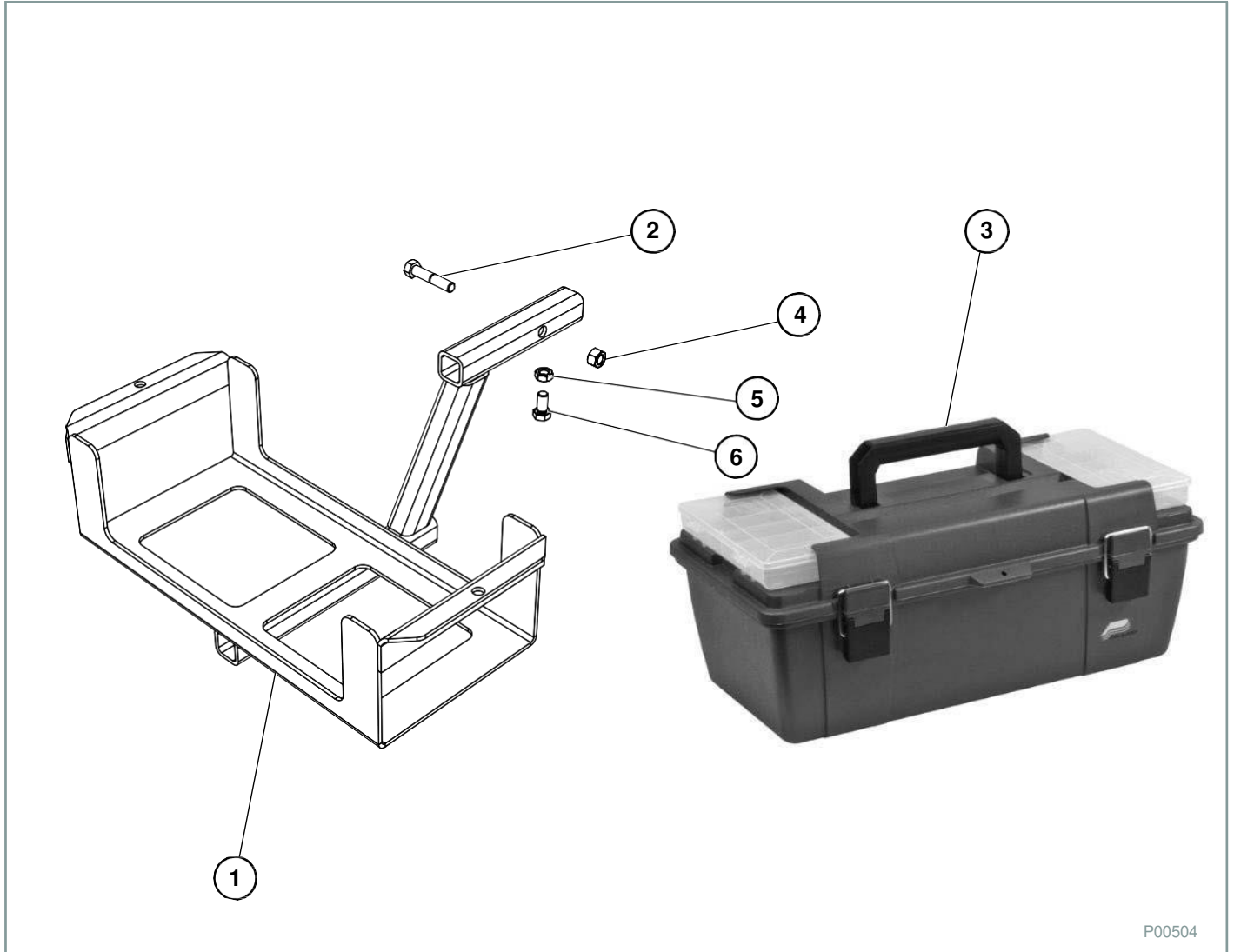

P00504

ITEM NO.	PART NO.	DESCRIPTION	QTY.
1	18426	TOOLBOX HOLDER	1
2	596155M	BOLT HEX HEAD 1/2 X 2-1/2: GRADE 5 ZP	1
3	790041	GRAB N GO TOOLBOX	1
4	596239M	NUT HEX HEAD 1/2 IN. CENTERLOCK ZP	1
5	596223M	NUT HEX HEAD 1/2 IN. JAM ZP	1
6	596152M	BOLT HEX HEAD 1/2 X 1: GRADE 5 ZP	1

## ILLUSTRATED PARTS LIST (CONT'D)

### Injector And Knife Kits Contents

PART NO.	DESCRIPTION	INJECTOR QTY.	KNIFE QTY.
520003	3 NOZZLE, SINGLE HOSE SHANK NYB 3	NA	2
520004	NOZZLE, DOUBLE HOSE SHANK NYB	NA	2
520005	NOZZLE, SINGLE HS CONN 1/4 IN. F	2	NA
520006	NOZZLE, DOUBLE HS CONN 1/4 IN. F	2	3
520014	NOZZLE, SS 1/4 IN. TEE	1	NA
520015	NOZZLE, SS CA	1	NA
520034	TIP, SS - 0015 TEEJET	2	NA
530001	1/4 IN. X 1/4 IN. MALE CONNECTOR	1	1
530014	1-1/2 IN. EDPM GASKET	2	2
530019	2 IN. EDPM GASKET	2	2
530024	3 IN. EDPM GASKET	2	2
530188	HOSE SHANK ASSEMBLY	1	NA
530201	BARB HOSE 1/4 IN. X 3/8 IN.	4	NA
530218	3/8 IN. X 3/8 IN. HOSE MENDER W/ STOP	2	NA
530236	NIPPLE:1/4 IN. MPTX6 IN. MPT	1	NA
530246	STR. ELB:1/4 IN. MPTX1/4 IN. FPT	1	NA
540001	CLAMP, 2 IN. STD WORM SCREW	1	1
540002	CLAMP, 2 IN. FULL WORM SCREW	1	1
540003	CLAMP, 3 IN. WORM SCREW	1	1
540006	CLAMP 1-1/2 IN. T-BOLT HOSE 1.81 IN.	2	2
540013	CLAMP, STAINLESS 3/4 IN. #12	10	5
540014	CLAMP, STAINLESS 1 IN. #16	NA	4
540032	CLAMP, HOSE 5/16 IN.	4	NA
590029	SEAL, EDPM RUBBER	NA	3
590030	CAP Q.T. NY.LT.YELLOW	NA	3
590031	PLATE ORIFICE, STAINLESS STEEL	NA	3
750008	LOCKING COLLAR, STD 30°	2	2
750016	ROCK GUARD WITH PIN	1	NA
750018	3/8 X 1/2 IN. SET SCREW, SS	2	NA
750019	MOUNTING BRACKET F/WIESE CO-50 KNIFE	NA	1
790041	20 IN. DEEP GRAB & GO TOOLBOX	1	1
AC40015	O-RING, VOLUTE SEAL	NA	1
AC40151	SEAL, 5/8 IN. SHAFT, VITON®-C	NA	1
AC52700	REPAIR KIT	1	NA
AP44103202	1/4 X 1/4 IN. UNION CONNECTOR	3	3
AP44103240	1/4 X 1/4 IN. FEMALE ADAPTOR	1	1
AXGC30020XXL	XXL GREEN GLOVES	1	1
LAXNVGOGGLES	GOGGLES	1	1
BJ200SHIM	2 IN. SHIM	NA	2
BJHM075	3/4 IN. X 3/4 IN. HOSE BARB	2	2
BJHM100	1 IN. X 1 IN. HOSE BARB	2	2
BJHM150	1-1/2 IN. X 1-1/2 IN. HOSE BARB	1	1
CLFBS1004	5/8 X 1 SQUARE HEAD SET SCREW	2	NA
PL707TB	REDURAN	1	1
WA21047	CABLE TIE, 15 IN. HEAVY DUTY	20	20
VI3K9438	BARB:3/8 IN. HB FOR 8027 NUT-POLY	NA	3

## ILLUSTRATED PARTS LIST (CONT'D)

### Lighting

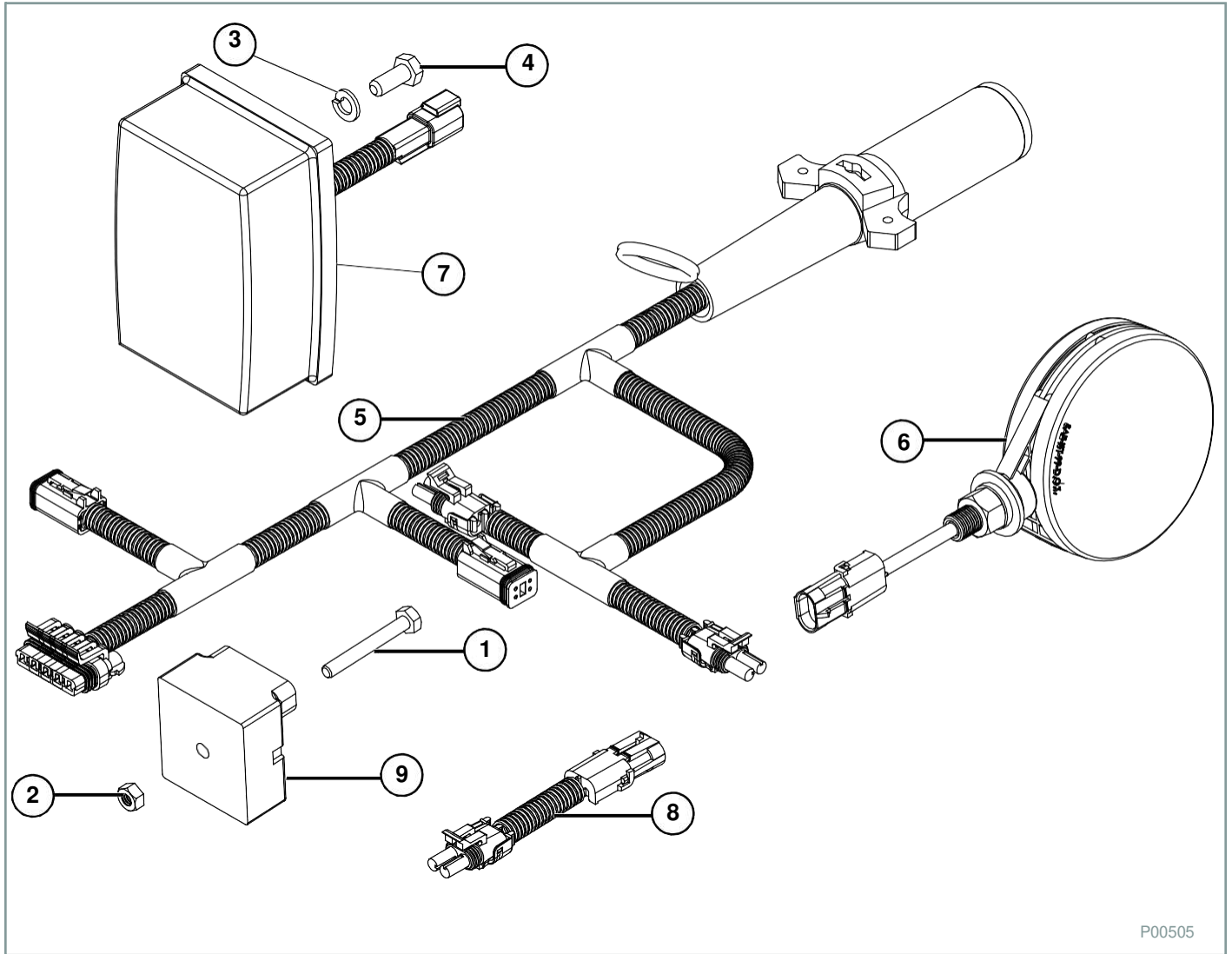

P00505

ITEM NO.	PART NO.	DESCRIPTION	QTY.
1	104	BOLT, 1/4 X 2" GRADE 5 ZP	1
2	235	NUT, CENTERLOCK, 1/4" ZP	1
3	249	WASHER, LOCK, 5/16" ZP	4
4	590229	BOLT, 8 X 20 MM 8.8 ZP	4
5	740023	APPLICATOR LIGHT WIRING HARNESS	1
6	740024	AMBER WARNING LIGHT	2
7	740025	RED TAILLIGHT	2
8	740030	EXTENSION	2
9	740031	LIGHT MODULE	1



**WARRANTY**

WARRANTY.....175





**WARRANTY**

# WARRANTY

## FAST Equipment

FAST AG Solutions warrants to the buyer that the new machinery is free from defects in material and workmanship.

This warranty is only effective as to any new machinery which has not been altered, changed, repaired or treated since its delivery to the buyer, other than by FAST AG Solutions or its authorized dealers or employees, and does not apply to accessories, attachments, tools or parts, sold or operated with the new machinery, if they have not been manufactured by FAST AG Solutions.

FAST AG Solutions shall only be liable for defects in the materials or workmanship attributable to faulty material or bad workmanship that can be proved by the buyer, and specifically excludes liability for repairs arising as a result of normal wear and tear of the new machinery or in any other manner whatsoever, and without limiting the generality of the foregoing, excludes application or installation of parts not completed in accordance with FAST AG Solutions operator's manual, specifications, or printed instructions.

Written notice shall be given by registered mail, to FAST AG Solutions within seven (7) days after the defect shall have become apparent or the repairs shall have become necessary, addressed as follows:

FAST AG Solutions  
4130 Commerce Blvd  
Windom, MN 56101

This warranty shall expire one (1) year after the date of delivery of the new machinery.

If these conditions are fulfilled, FAST shall at its own cost and at its own option either repair or replace any defective parts provided that the buyer shall be responsible for all expenses incurred as a result of repairs, labor, parts, transportation or any other work, unless FAST has authorized such expenses in advance.

The warranty shall not extend to any repairs, changes, alterations, or replacements made to the new equipment other than by FAST or its authorized dealers or employees.

This warranty extends only to the original owner of the new equipment.

Rubber parts (including tires, hoses, grommets) are not warranted.

This warranty is limited to the terms stated herein and is in lieu of any other warranties whether express or implied, and without limiting the generality of the foregoing, excluded all warranties, express or implied or conditions whether statutory or otherwise as to quality and fitness for any purpose of the new equipment. FAST disclaims all liability for incidental or consequential damages.

This Applicator is subject to design changes and FAST AG Solutions shall not be required to retrofit or exchange items on previously sold units except at its own option.

FAST AG Solutions

Warranty void if not registered.

Warranty Department



Printed in U.S.A.





**ALPHABETICAL INDEX**

EQUIPMENT SPECIFICATIONS.....26

FEATURES AND ACCESSORIES..... 5

FIELD OPERATION.....43

FIRE PREVENTION..... 11

GENERAL DESCRIPTION..... 24

GENERAL INFORMATION AND OPERATING INSTRUCTION SAFETY  
PRECAUTIONS.....21

ILLUSTRATED PARTS LIST.....69

INTRODUCTION..... 3

MAINTENANCE AND REPAIR SAFETY PRECAUTIONS.....55

MAINTENANCE PROCEDURES..... 62

MAJOR COMPONENTS.....25

MANUFACTURER’S INFORMATION..... 4

POST-OPERATION DISCONNECTION..... 48

PRE-OPERATION SETUP.....28

PREVENTATIVE MAINTENANCE..... 55

PURPOSE OF EQUIPMENT.....24

SAFETY IDENTIFICATION..... 14

SAFETY PRECAUTIONS.....9

SERIAL NUMBER LOCATION..... 4

SIGN-OFF FORM..... 13

SPECIFICATIONS..... 64

STORAGE INSTRUCTIONS.....51

TRANSPORTATION..... 49

TROUBLESHOOTING.....66

WARRANTY..... 177



**FAST Ag Solutions**  
*4130 Commerce Boulevard*  
*Windom, MN 56101*

1-800-772-9279 Toll Free  
1-507-427-3861 Voice  
1-507-427-3030 Fax  
[www.fastsprayers.com](http://www.fastsprayers.com)