



833P / 813P - 30' / 40' / 60'
3PT APPLICATOR
OWNER'S MANUAL





Table of Contents

Section	Page
Table of Contents	3
Warranty Registration	8
<i>Warranty Inspection Report</i>	<i>8</i>
Inspections	10
<i>Pre-Delivery</i>	<i>10</i>
<i>Delivery</i>	<i>11</i>
<i>After-Sale</i>	<i>12</i>
Owner Register	13
Foreword to the Owner	14
INTRODUCTION	16
SAFETY	17
<i>Safety Alert Symbols and Signal Words</i>	<i>17</i>
<i>General Safety</i>	<i>18</i>
Prepare for Emergencies	<i>18</i>
Wear Protective Clothing	<i>18</i>
Protect Against Noise	<i>18</i>
Practice Safe Maintenance	<i>18</i>
Support Raised Equipment	<i>19</i>
Avoid Heating Near Pressurized Fluid Lines	<i>19</i>
Avoid High-Pressure Fluids	<i>19</i>
Inspect Lift Circuit Hoses	<i>20</i>
Store Attachments Safely	<i>20</i>
Electrical	<i>20</i>
Service Tires Safely	<i>20</i>
Dispose of Waste Properly	<i>21</i>
Handle Agricultural Chemicals Safely	<i>21</i>
Reduce risk of exposure and injury:	<i>21</i>
Handle Chemical Products Safely	<i>22</i>
Operate Hydraulics Safely	<i>22</i>
Use Safety Lights and Devices	<i>23</i>
Keep Riders Off Machine	<i>23</i>
Observe Maximum Transport Speed	<i>23</i>
EC Compliance Notification	<i>24</i>
Use a Signal Person	<i>24</i>
Tow Loads Safely	<i>24</i>
Avoid Overhead Power Lines	<i>24</i>



Prepare for Transport.....	25
Transport Safely	25
<i>Replace Safety Signs.....</i>	<i>26</i>
Wing.....	26
<i>Safety Features.....</i>	<i>27</i>
<i>Sign-Off Form</i>	<i>28</i>
SPECIFICATIONS	29
<i>Tractor Power, Size Recommendation</i>	<i>29</i>
<i>Hydraulic System Requirements</i>	<i>29</i>
<i>Machine Dimensions & Specifications.....</i>	<i>30</i>
PREPARING THE MACHINE	31
<i>Use the Tractor Operator’s Manual.....</i>	<i>31</i>
<i>Break-In</i>	<i>31</i>
<i>Pre-Operation Checklist.....</i>	<i>32</i>
AXLES, TIRES, and TRACKS	33
<i>Checking Tire Pressure</i>	<i>33</i>
<i>Checking Wheel Nuts</i>	<i>33</i>
ATTACHING and DETACHING	34
<i>Attach the Machine Safely.....</i>	<i>34</i>
<i>Attach the Machine to the Tractor</i>	<i>34</i>
<i>Attach Warning Light Plug.....</i>	<i>34</i>
<i>Connect Rate Controller or Nutrient Applicator System Wiring</i>	<i>35</i>
<i>Make Proper Hose Connections.....</i>	<i>35</i>
<i>SCV Identification Chart.....</i>	<i>36</i>
TRANSPORTING	37
<i>Following Safe Transport Procedures</i>	<i>37</i>
<i>Preparing the Machine for Transport.....</i>	<i>37</i>
Fold Toolbar for Transport.....	37
Transport Notes and Checks	37
<i>Transporting the Machine</i>	<i>38</i>
Using Warning Lights	38
Keep Riders Off the Machine	38
<i>Caution for All Machines</i>	<i>38</i>
<i>Unfolding/Extending the Toolbar</i>	<i>39</i>
Field Operation Notes	39
Outer Wing of 40’ Machines	39



HYDRAULIC FLOW	40
<i>Regulating Hydraulic Flow to the Pump</i>	<i>41</i>
Load Sensing Closed Center System (LS Closed)	41
Pressure Compensating Closed-Center System (PC Closed)	41
Open Center System (Open)	42
<i>Tractor SCV Functions</i>	<i>42</i>
ADJUST DEPTH CONTROL	44
<i>Adjust Application Depth</i>	<i>44</i>
<i>Down Pressure Adjustment</i>	<i>44</i>
<i>Adjust Gauge Wheels</i>	<i>45</i>
ADJUST GROUND SPEED	45
ADJUST NOZZLES.....	46
<i>Adjust Knives</i>	<i>46</i>
PREPARING THE LIQUID SYSTEM	47
<i>Clean Strainer Filter</i>	<i>47</i>
LUBRICATION & MAINTENANCE.....	48
<i>Lubricating and Maintaining the Machine Safely</i>	<i>48</i>
<i>Lubricant Storage</i>	<i>48</i>
<i>Grease</i>	<i>48</i>
Greases for Air Temperature Ranges.....	48
Alternative and Synthetic Lubricants	48
<i>Lubrication and Maintenance Intervals.....</i>	<i>49</i>
Each 10 hours or Daily.....	49
Each 50 Hours or Weekly	49
SERVICE	50
<i>Practice Safe Maintenance.....</i>	<i>50</i>
<i>Work in a Clean Area.....</i>	<i>50</i>
<i>Service Machines Safely</i>	<i>50</i>
<i>Support the Machine Properly</i>	<i>51</i>
<i>Avoid High-Pressure Fluids</i>	<i>51</i>
<i>Preventing Hydraulic System Contamination</i>	<i>51</i>
<i>Replace Hydraulic Hoses</i>	<i>52</i>
<i>Tightening Hardware</i>	<i>52</i>
PREPARING FOR STORAGE	53
<i>Removing from Storage.....</i>	<i>53</i>

TIGHTENING HARDWARE	54
<i>Metric Bolt and Screw Torque Values</i>	<i>54</i>
<i>Unified Inch Bolt and Screw Torque Values</i>	<i>55</i>
<i>Face Seal Fittings Assembly & Installation - All Pressure Applications</i>	<i>56</i>
Face Seal O-Ring to Stud End Installation	56
Face Seal Adjustable Stud End O-Ring Installation	56
Face Seal Straight Stud End O-Ring Installation	56
Fitting Installation	56
Assembly Torque	56
<i>SAE Face Seal and O-Ring Stud End Fitting Torque Chart</i>	<i>57</i>





Limited Warranty

Fast Ag Solutions warrants to the buyer that the new machinery is free from defects in material and workmanship.

This warranty is only effective as to any new machinery which has not been altered, changed, repaired or treated since its delivery to the buyer, other than by Fast Ag Solutions or its authorized dealers or employees, and does not apply to accessories, attachments, tools or parts, sold or operated with the new machinery, if they have not been manufactured by Fast Ag Solutions.

Fast Ag Solutions shall only be liable for defects in the materials or workmanship attributable to faulty material or bad workmanship that can be proved by the buyer, and specifically excludes liability for repairs arising as a result of normal wear and tear of the new machinery or in any other manner whatsoever, and without limiting the generality of the foregoing, excludes application or installation of parts not completed in accordance with this Operator's Manual, specifications, or printed instructions.

Written notice shall be given by registered mail, to the Manufacturer within seven (7) days after the defect shall have become apparent or the repairs shall have become necessary, addressed as follows:

Fast Ag Solutions
4130 Commerce Boulevard
Windom, MN 56101

This warranty shall expire one (1) year after the date of delivery of the new machinery.

If these conditions are fulfilled, Fast Ag Solutions shall at its own cost and at its own option either repair or replace any defective parts provided that the buyer shall be responsible for all expenses incurred as a result of repairs, labor, parts, transportation or any other work, unless Fast Ag Solutions has authorized such expenses in advance.

The warranty shall not extend to any repairs, changes, alterations, or replacements made to the new equipment other than by Fast Ag Solutions or its authorized dealers or employees.

This warranty extends only to the original owner of the new equipment.

Rubber parts (including tires, hoses, grommets) are not warranted.

This warranty is limited to the terms stated herein and is in lieu of any other warranties whether express or implied, and without limiting the generality of the foregoing, excluded all warranties, express or implied or conditions whether statutory or otherwise as to quality and fitness for any purpose of the new equipment. The Manufacturer disclaims all liability for incidental or consequential damages.

This 3PT Applicator is subject to design changes and Fast Ag Solutions shall not be required to retrofit or exchange items on previously sold units except at its own option.

Warranty void if not registered.



FAST 3PT APPLICATOR

Warranty Registration

This form must be filled out by the dealer and signed by both the dealer and the customer at the time of delivery.

Customer Name					
Address					
City		State		Zip	
Phone					

Dealer Name					
Address					
City		State		Zip	

Applicator Model					
Serial Number					
Delivery Date					

Warranty Inspection Report

DEALER INSPECTION REPORT

- All Fasteners Tight
- Wheel Bolts Torqued
- Hydraulic Hoses and Fittings Free and Tight
- Fertilizer Hoses and Fittings Free and Tight
- Wheels Turn Freely
- Lubricate Machine
- Check Tire Pressure
- Frame and Wings Level
- Monitors and Controllers Function
- Wiring Harness Connected

SAFETY

- Safety Chain Installed
- All Guards Installed
- All Safety Signs Installed
- Reflectors, SMV, and Lights Clean
- Review Operating and
- Safety Instructions

I have thoroughly instructed the buyer on the above-described equipment which review included the Operator's Manual content, equipment care, adjustments, safe operation, and applicable warranty policy.

Date _____

Dealer's Rep. Signature _____

The above equipment and Operator's Manual have been received by me, and I have been thoroughly instructed as to care, adjustments, safe operation, and applicable warranty policy.

Date _____

Owner's Signature _____

White - FAST
Yellow - Dealer
Pink - Customer



FAST 833P / 813P Series Applicator

APPLICATOR SERIAL NUMBER _____

DATE PURCHASED _____ / _____ / _____

NUMBER OF ROW UNITS _____

PUMP MANUFACTURER:

(CIRCLE ONE)

ACE FMC-150-HYD-206

ACE FMCS-205F-HYD-304

**ACE FMCS-205F-HYD-304
PWM**

HYPRO 9306C-HM1C

Inspections

Pre-Delivery

After the machine has been completely assembled, inspect it to be sure it is in good running order before delivering it to the customer. Ensure each item is found satisfactory or proper adjustment to the item(s) is made.

The following checklist is a reminder of points to inspect. It is neither an exclusive nor an exhaustive list of points to inspect. See the [Warranty Inspection Report](#) for a formal list.

- **SMV** emblem is installed, protective **shipping tape** is removed from reflectors, and **lights** are installed.
- All **grease fittings** are lubricated (see [LUBRICATION and MAINTENANCE](#) section in this Manual.)
- Inspect to be sure all **nuts** are tightened to proper torque and all **cotter pins** are spread.
- The **tires** are properly inflated (see [SPECIFICATIONS](#)).
- **Wheel bolts** are tightened to their specified torque(s).
- Fertilizer **row units** are properly adjusted.
- Warning **lights** are properly installed and operational.
- All customer-ordered **attachments** are installed or are available for delivery.
- Any parts scratched in shipment are touched up with **paint**.
- All **shipping decals** are removed.
- **Transport pins** are inserted in the transport holes.

This machine has been thoroughly checked and to the best of my knowledge is ready for delivery to the customer.

Signed: _____

Date: _____



Delivery

The following checklist is a reminder of information which should be conveyed directly to the customer at the time the machine is delivered.

Check off each item as it is fully relayed to the customer.

- Tell the customer to use proper tools.
- Explain to the customer that the life expectancy of this or any other machine depends on regular lubrication as directed in Operator's Manual.
- Make the customer aware of all safety precautions that must be followed while using this machine.
- When the machine is transported on a road or highway at night or during the day, accessory lights and devices should be used for adequate warning to Operators of other vehicles. For this matter, tell the customer to check local governmental regulations.
- Give the Operator's Manual to the customer and explain all operating adjustments.

To the best of my knowledge, this machine has been delivered ready for field use, and the customer has been fully informed as to its proper care and operation.

Signed: _____

Date: _____



After-Sale

The following is a suggested list of items to be checked at a dealer-customer mutually agreeable time during the first operating season.

- Check with the customer as to performance of machine. Make certain proper operating adjustments are understood.
- If possible, operate the machine to see that it is functioning properly.
- Acquaint the customer with any special attachment which will help do a better job.
- Go over the entire machine for loose or missing hardware.
- Check for broken or damaged parts.
- Ask the customer if recommended periodic lubrication has been performed.
- Review the Operator's Manual with the customer and stress the importance of proper lubrication and safety precautions.

Signed: _____

Date: _____



Owner Register

Model Number	Serial Number
---------------------	----------------------

Name		
Address		
County	State	Date Purchased

Name		
Address		
County	State	Date Purchased

Name		
Address		
County	State	Date Purchased

Name		
Address		
County	State	Date Purchased

Foreword to the Owner



Congratulations on your choice of an 3PT Applicator to complement your agricultural operation!

READ THIS MANUAL carefully to learn how to operate and service your machine correctly. Failure to do so could result in personal injury or equipment damage. This Manual and safety signs on your machine may also be available in other languages.

THIS MANUAL SHOULD BE CONSIDERED a permanent part of your machine and should remain with the machine when you sell it.

MEASUREMENTS in this Manual are given in both metric and customary U.S. unit equivalents. Use only correct replacement parts and fasteners. Metric and inch fasteners may require a specific metric or inch wrench.

RIGHT-HAND AND LEFT-HAND sides are determined by facing in direction that the implement will travel when going forward.

WRITE SERIAL NUMBER of the machine in the [Specification](#) section and in the [Owner Register](#). Accurately record all numbers to help in tracing your machine should it be stolen. Your dealer also needs these numbers when you order parts. File identification numbers in a safe place off-machine.

BEFORE DELIVERING THIS MACHINE, your dealer performed a pre-delivery inspection.

THIS 3PT APPLICATOR IS DESIGNED SOLELY for use in customary agricultural or similar operations for the purpose of applying chemical to row crops (“Intended Use”). Use in any other way is considered as contrary to the Intended Use. The manufacturer accepts no liability for damage or injury resulting from this misuse, and these risks must be borne solely by the user.



Compliance with and strict adherence to the conditions of operation, service, and repair as specified by the manufacturer also constitute essential elements for the Intended Use.

THIS 3PT APPLICATOR SHOULD BE OPERATED, serviced, and repaired only by persons familiar with all its particular characteristics and acquainted with the relevant safety rules (Accident Prevention). The Accident Prevention regulations, all other generally recognized regulations on safety and occupational medicine and the road traffic regulations must be observed at all times.

Any arbitrary modifications carried out on this 3PT Applicator will relieve the manufacturer of all liability for any resulting damage or injury.

THIS DOCUMENT outlines the specific design and performance requirements for the use of a Fast Ag Solutions 3PT Applicator assembly. The word “must” in this document indicates a mandatory requirement. The use of “should” indicates a recommendation of that which is advised but not required.

WARRANTY is provided as part of Fast Ag Solutions' support program for customers who operate and maintain their equipment as described in this Manual. The warranty is explained on the warranty certificate which you should have received from your dealer.

This warranty provides you with assurance that Fast Ag Solutions will back its products where defects appear within the warranty period. In some circumstances, Fast Ag Solutions also provides field improvements, often without charge to the customer, even if the product is out of warranty. Should equipment be abused or modified to change its performance beyond original factory specifications, the warranty will become void and field improvements may be denied.

TIRE MANUFACTURER'S warranty applicable to your machine may not apply outside U.S.

If you are not the original owner of this machine, it is in your interest to contact your local Fast Ag Solutions dealer to inform them of this unit's serial number. This will help Fast Ag Solutions notify you of any issues or product improvements.

INTRODUCTION



Read this Manual carefully before operating your FAST equipment. The information presented will prepare you to safely operate and service your machine.

All Operators are required to read this Manual carefully and be acquainted with all the operating and adjustment procedures before attempting to operate. Failure to follow the information in this Manual and on decals may result in personal injury or equipment damage.

This Manual should be considered a permanent part of this equipment and should remain with the equipment when you sell it. Replacement manuals can be obtained from your Fast Ag Solutions dealer.

This equipment has been engineered and manufactured to provide dependable and satisfactory use. Like all mechanical products, it will require cleaning and upkeep. Inspect your equipment before putting it into service. Your authorized Fast Ag Solutions dealer has trained mechanics, genuine FAST service parts, and the necessary tools and equipment when service is needed. Use only genuine FAST parts for service or repairs. Substitute parts will void the warranty and may not meet standards for safe and satisfactory operation.

Warranty is provided as part of Fast Ag Solutions' support program for customers who operate and maintain their equipment as described in this Manual. The warranty is explained on the warranty certificate you should have received from your dealer. This warranty provides you with the assurance that Fast Ag Solutions will back its products where defects appear within the warranty period. Should the equipment be abused or modified to change its performance beyond the original factory specifications, the warranty will become void.

These instructions have been compiled from field experience and engineering data. Some information may be general in nature due to unknown and varying operating conditions. However, through experience and these instructions, you should be able to develop procedures suitable to your particular situation.

.....

The illustrations and data used in this Manual were current at the time of printing. However, due to possible in-line production changes, your machine may vary slightly in detail. We reserve the right to redesign and change the machines as necessary without notification.

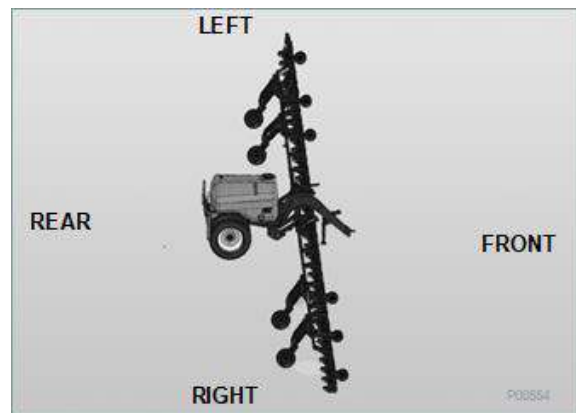

Figure 1: Orientation is viewed from behind the machine

SAFETY

The most important safety device on this equipment is a safe Operator. It is the Operator's responsibility to read and understand and follow all safety and operating instructions in this Manual.

As the Operator, you are responsible for the safe operation and maintenance of this equipment. You must ensure that you and anyone else who is going to operate, maintain or work around the machine is familiar with the operating and maintenance procedures and related safety information contained in this Manual.

You are the key to safety. Good safety practices protect you and the people around you. Be certain that everyone operating this equipment is familiar with the recommended operating and maintenance procedures and follows all safety precautions. Do not risk injury or death by ignoring good safety practices.

Safety Alert Symbols and Signal Words



This is a Safety Alert Symbol. When you see this symbol on your machine or in this Manual, be alert to the potential for personal injury.

Follow recommended precautions and safe operating practices.

Understand Signal Words

Throughout this Manual, the terms *CAUTION*, *WARNING*, and *DANGER* are used along with the Safety Alert Symbol to indicate the degree of personal safety hazard. The term *IMPORTANT* is used to indicate that failure to observe the hazard can cause damage to the equipment.



DANGER identifies the most serious hazards. DANGER or WARNING safety signs are located near specific hazards. General precautions are listed on CAUTION safety signs. CAUTION also calls attention to safety messages in this Manual.

Follow Safety Instructions

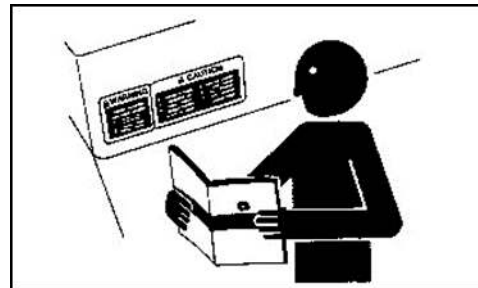

Carefully read all safety messages in this Manual and on your machine's safety signs. Keep safety signs in good condition.

Replace missing or damaged safety signs. Be sure new equipment components and repair parts include the current safety signs. Replacement safety signs are available from your Fast Ag Solutions dealer. There can be additional safety information contained on parts and components sourced from suppliers that is not reproduced in this Operator's Manual.

Learn how to operate the machine and how to use controls properly. Do not let anyone operate without instruction.

Keep your machine in proper working condition. Unauthorized modifications to the machine may impair the function and/or safety and affect machine life.

If you do not understand any part of this Manual and need assistance, contact your Fast Ag Solutions dealer.

General Safety

Prepare for Emergencies

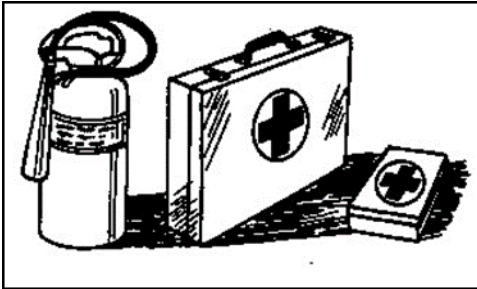

Be prepared if a fire starts.

Keep a first aid kit and fire extinguisher handy.

Keep emergency numbers for the poison control center, doctors, ambulance service, hospital, and fire department near your telephone.

In case of poisoning, get immediate medical attention.

Wear Protective Clothing

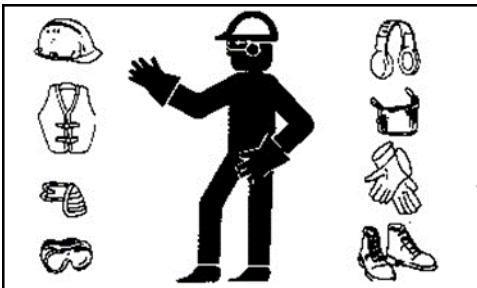

Wear close-fitting clothing and safety equipment appropriate to the job.

Operating equipment safely requires the full attention of the Operator. Do not wear radio or music headphones while operating the machine.

Keep hands, feet, hair, and clothing away from all moving and/or rotating parts.

Protect Against Noise



Prolonged exposure to loud noise can cause impairment or loss of hearing.

Wear a suitable hearing protective device such as earmuffs or earplugs to protect against objectionable or uncomfortable loud noises.

Practice Safe Maintenance



Understand service procedures before doing work. Keep the area clean and dry.

Never lubricate, service, or adjust the machine while it is moving. Keep hands, feet, and clothing away from power-driven parts. Disengage all power and operate controls to relieve pressure. Lower equipment to the ground. Stop the engine. Remove the key. Allow machine to cool. Securely support any

machine elements that must be raised for service work.

Keep all parts in good condition and properly installed. Fix any damage immediately. Replace worn or broken parts. Remove any buildup of grease, oil, or debris.

On self-propelled equipment, disconnect the battery ground cable (-) before making any adjustments on electrical systems or welding on the machine.

On towed implements, disconnect wiring harnesses from tractor before servicing electrical system components or welding on the machine.

Support Raised Equipment



Always use a safety support when working on, under, or around the machine. Transport/Service locks can be used for this purpose.

Shut off the tractor's engine and remove the key when working on the machine.

If air has been allowed to enter hydraulic hoses or cylinders, bleed the hydraulic system before use. If there is a failure in the hydraulic system, unsupported or raised equipment could suddenly lower, causing serious personal injury or death.

If support is not available, completely lower wings and frame, relieve hydraulic pressure and disconnect hoses from tractor.

Avoid Heating Near Pressurized Fluid Lines



Flammable spray can be generated by heating near pressurized fluid lines, resulting in severe burns to yourself and bystanders. Do not heat by welding, soldering, or using a torch near pressurized fluid lines or other flammable materials. Pressurized lines can accidentally burst when heat goes beyond the immediate flame area.

Avoid High-Pressure Fluids



Inspect hydraulic hoses periodically – at least once per year – for leakage, kinking, cuts, cracks, abrasion, blisters, corrosion, exposed wire braid, or any other signs of wear or damage.

Replace worn or damaged hose assemblies immediately with Fast Ag Solutions approved replacement parts.

Escaping fluid under pressure can penetrate the skin causing serious injury.

Avoid the hazard by relieving pressure before disconnecting hydraulic or other lines. Tighten all connections before applying pressure.

Search for leaks with a piece of cardboard. Protect hands and body from high-pressure fluids.

If an accident occurs, see a doctor immediately. Any fluid injected into the skin must be surgically removed within a few hours or gangrene may result. Doctors unfamiliar with this type of injury should reference a knowledgeable medical source.

Inspect Lift Circuit Hoses

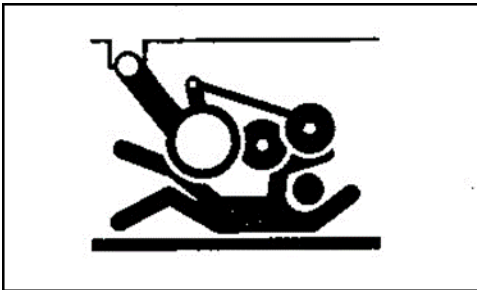

Avoid serious injury or death while working under a raised implement. Hydraulic hoses between the lift cylinders and hydraulic lock-up valves should be inspected frequently for leakage, kinking, cuts, cracks, abrasion, blisters, corrosion, exposed wire braid, or any other signs of wear or damage. Worn or damaged hose assemblies can fail during use and should be replaced immediately. See your Fast Ag Solutions dealer for replacement hoses.

Store Attachments Safely

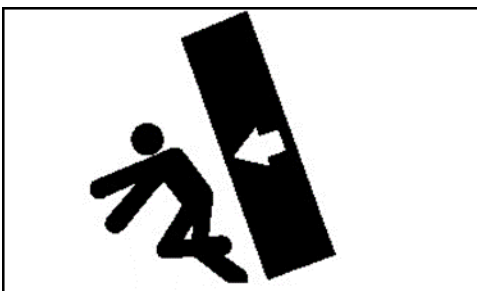

Stored attachments such as dual wheels can fall and cause serious injury or death. Securely store attachments and implements

to prevent falling. Keep playing children and bystanders away from storage area.

Electrical



Check all electrical wiring and connections for damage. Keep the battery terminals clean and tight. Repair or replace any damaged part or wires that are loose or frayed.

Service Tires Safely

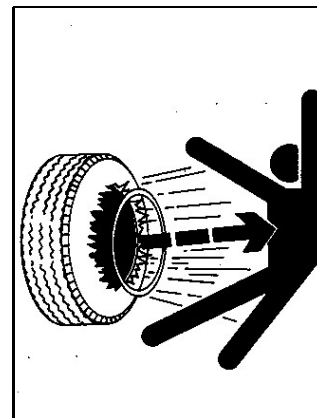

CAUTION: Explosive separation of a tire and rim parts can cause serious injury or death.

Do not attempt to mount a tire unless you have the proper equipment and experience to perform the job.

Never weld or heat a wheel and tire assembly. The heat can cause an increase in air pressure resulting in a tire explosion. Welding can structurally weaken or deform the wheel.

Always maintain the correct tire pressure. Do not inflate the tires above the recommended pressure. Never weld or heat a wheel and tire assembly. The heat can cause an increase in air pressure resulting in a tire explosion.

Welding can structurally weaken or deform the wheel.

When inflating tires, use a clip-on chuck and extension hose long enough to allow you to stand to one side and NOT in front of or over the tire assembly. Use a safety cage if available.

Check wheels for low pressure, cuts, bubbles, damaged rims, or missing lug bolts and nuts. Replace as necessary.

Dispose of Waste Properly

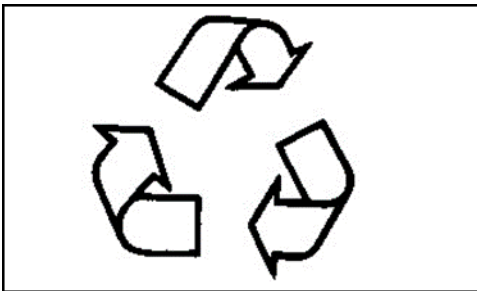

Improperly disposing of waste can threaten the environment and ecosystem. Potentially harmful waste used with equipment includes such items as oil, fuel, coolant, brake fluid, filters, and batteries.

Use leakproof containers when draining fluids. Do not use food or beverage containers that may mislead someone into drinking from them.

Do not pour waste onto the ground, down a drain, or into any water source.

Air conditioning refrigerants escaping into the air can damage the Earth's atmosphere. Government regulations may require a certified air conditioning service center to recover and recycle used air conditioning refrigerants.

Handle Agricultural Chemicals Safely

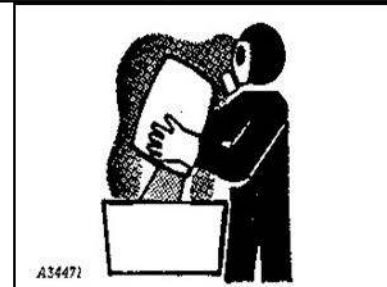
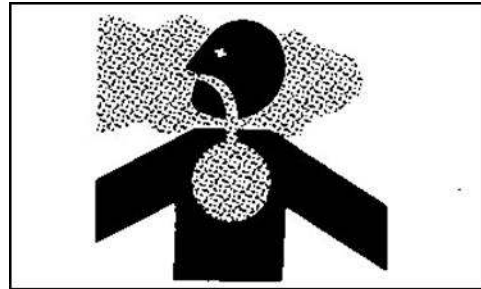

Chemicals used in agricultural applications such as fungicides, herbicides, insecticides, pesticides, rodenticides, and fertilizers can be harmful to your health or the environment if not used carefully.

Always follow all label directions for effective, safe, and legal use of agricultural chemicals.

Reduce risk of exposure and injury:

Wear appropriate personal protective equipment as recommended by the manufacturer. In the absence of manufacturer's instructions, follow these general guidelines:

Chemicals labeled 'Danger' (Most toxic) generally require use of goggles, respirator, gloves, and skin protection.

Chemicals labeled 'Warning' (Less toxic) generally require use of goggles, gloves, and skin protection.

Chemicals labeled 'Caution' (Least toxic) generally require the use of gloves and skin protection.

Avoid inhaling vapor, aerosol, or dust.

Always have soap, water, and a towel available when working with chemicals. If a chemical contacts skin, hands, or face, wash

immediately with soap and water. If chemical gets into eyes, flush immediately with water.

Wash hands and face after using chemicals and before eating, drinking, smoking, or urination.

Do not smoke or eat while applying chemicals.

After handling chemicals, always bathe or shower and change clothes. Wash clothing before wearing it again.

Seek medical attention immediately if illness occurs during or shortly after use of chemicals.

Keep chemicals in original containers. Do not transfer chemicals to unmarked containers or to containers used for food or drink.

Store chemicals in a secure, locked area away from human or livestock food. Keep children away.

Always dispose of containers properly. Triple rinse empty containers and puncture or crush containers and dispose of properly.

Handle Chemical Products Safely



Direct exposure to hazardous chemicals can cause serious injury. Potentially hazardous chemicals used with FAST equipment include such items as lubricants, coolants, paints, and adhesives.

A Material Safety Data Sheet (M/SDS) provides specific details on chemical products: physical and health hazards, safety procedures, and emergency response techniques.

Check the M/SDS before you start any job using a hazardous chemical. That way you will know exactly what the risks are and how to do the job safely. Then follow the procedures with the recommended equipment.

Operate Hydraulics Safely



Before operating, make sure air has been bled from wing-fold hydraulic system.

Be sure the area around the machine is clear before raising or lowering the machine's frame or wings.

Do not operate with wings folded.

Do not operate close to the edge of a ditch, creek, gully, or steep embankment. Avoid holes, ditches, and obstructions which may cause the tractor, machine, or towed equipment to roll over, especially on hillsides.

Avoid sharp turns on hillsides.

Slow down when turning, traveling over rough ground, or when turning on inclines.

Always shut off tractor and shift to PARK or set brakes when leaving tractor. Remove key when leaving tractor unattended.

Always have the tractor stop on level ground when raising or lowering wings. Operate the machine from tractor seat only. If chemicals are used, follow the manufacturer's recommendations for handling and storage.

Tow the machine behind a properly equipped tractor only.

Use Safety Lights and Devices

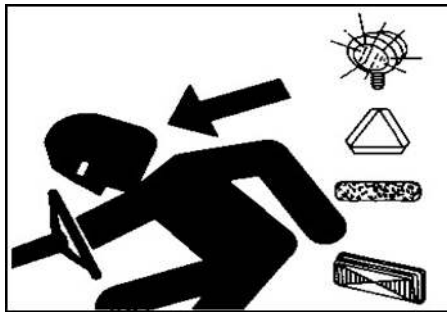

Prevent collisions between other road users, slow moving tractors with attachments or towed equipment, and self-propelled machines on public roads. Frequently check for traffic from the rear, especially in turns, and use turn signal lights.

Use headlights, flashing warning lights, and turn signals during both day and night. Follow local regulations for equipment lighting and marking. Keep lighting and marking visible, clean, and in good working order. Replace or repair lighting and marking that has been damaged or lost.

Keep Riders Off Machine

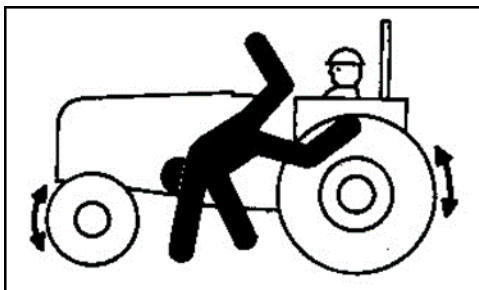

Only allow the Operator on the machine. Keep riders off.

Riders on the machine are subject to injury such as being struck by foreign objects and being thrown off of the machine. Riders also obstruct the Operator's view resulting in the machine being operated in an unsafe manner.

Observe Maximum Transport Speed

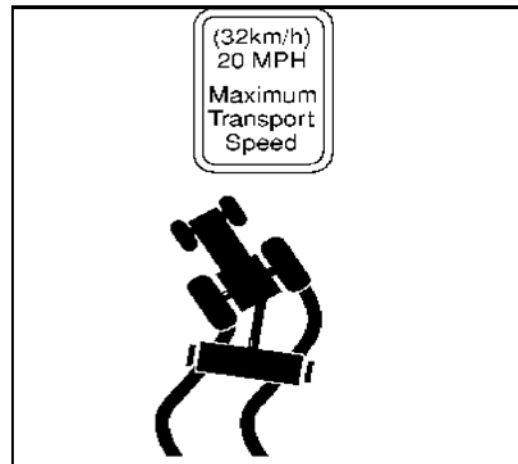

⚠ CAUTION: Be sure all bystanders are clear of Applicator.

This implement is not equipped with service or parking brakes. The maximum transport speed for this implement is 20 MPH (32 KPH).

Some tractors are capable of operating at speeds that exceed the maximum transport speed of this implement. Regardless of the maximum speed capability of the tractor being used to tow this implement, do not exceed the implement's maximum transport speed.

Exceeding the implement's maximum transport speed can result in:

- Loss of control of the tractor/implement combination.
- Reduced or no ability to stop during braking.
- Implement tire failure.
- Damage to the implement structure or its components.

Use additional caution and reduce speed when operating under adverse surface conditions, when turning, and when on inclines.

EC Compliance Notification

**MACHINE DOES NOT COMPLY WITH
MACHINERY DIRECTIVE 2006/42/EC
NOT FOR EUROPEAN MARKET**

- ▲ WARNING:** Environmental transportation hazard. A loaded machine driven on public roads has a high risk of tire failure. Do not use the machine for transporting product(s) on public roads.

Use a Signal Person



Use a signal person to direct movement of the tractor / implement combination, whenever the tractor operator's view is obstructed.

Designate one individual as THE signal person. Always have the signal person stand in clear view. Be sure the signal person stays a safe distance away from the machine when it is moving.

Prior to starting the tractor, discuss hand signals and what each signal means to avoid misunderstandings and confusion which could result in a serious injury or fatal accident for someone.

Keep all bystanders away whenever the machine is moved.

Tow Loads Safely



Stopping distance increases with speed and weight of towed loads and on slopes. Towed loads with or without brakes that are too heavy for the tractor or are towed too fast can cause loss of control. Consider the total weight of the equipment and its load.

Observe these recommended maximum road speeds or local speed limits which may be lower:

If towed equipment does not have brakes, do not travel more than 32 km/h (20 mph) and do not tow loads more than 1.5 times the tractor weight.

Ensure the load does not exceed the recommended weight ratio. Add ballast to the recommended maximum for the tractor, lighten the load, or get a heavier towing unit. The tractor must be heavy and powerful enough with adequate braking power for the towed load. Use additional caution when towing loads under adverse surface conditions, when turning, and on inclines.

Avoid Overhead Power Lines

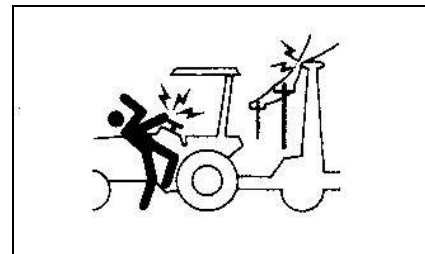

- ▲ WARNING:** Keep away from overhead power lines. Serious injury or death may result.

Proceed cautiously under overhead power lines and around utility poles. Know the transport height of your machine. Electrocutation can occur without direct contact with overhead electrical lines.

Prepare for Transport

⚠ CAUTION: Avoid serious injury or death to your or others.

Never tow the machine behind a truck or other motor vehicle. This machine is designed only to be towed with a properly sized and ballasted tractor.

Use a tractor large enough to maintain control. Properly ballast tractor for towing your machine. Refer to tractor Operator's Manual and this Manual to ensure that machine can be safely transported with your tractor.

Be aware of height and width restrictions to avoid a collision with overpasses or other road users.

Always fold wings fully. If wing fold cylinders are removed, chain wings together to prevent accidental lowering. Fully raise frame, close hydraulic lock-up valve (if equipped) and install Transport/Service locks before transporting. Latch the tractor brakes together.

⚠ IMPORTANT: Do not transport on a roadway unless the machine is equipped with proper functioning lights and reflective markings or emblems.

Ensure that the lights and reflective markings or emblems are clean and visible. Contact your Fast Ag Solutions dealer for lights and lighting harnesses.

Always follow local and national regulations for equipment size, lighting and marking before driving on public roadways. You are responsible for understanding and complying with all requirements regarding roadway

transport. Refer to [Use Safety Lights and Devices](#).

Transport Safely



⚠ CAUTION: When transporting, always travel at a reasonable and safe speed which permits adequate control of steering and stopping.

Reduce speed considerably when traveling over rough ground. Be certain everyone is clear of the machine.

Do not exceed weight and speed guidelines. Refer to [Observe Maximum Transport Speed](#).

Towed loads can swerve and upset or cause loss of control. Refer to [Tow Loads Safely](#). Shift tractor into a lower gear when transporting down steep slopes or hills; never coast. Stop slowly.

Wide turns may be required with the machine in tow. Use caution in traffic and in congested areas.

To improve stability when traveling through the field, wings should be unfolded from transport position as soon as possible after leaving the roadway.

⚠ IMPORTANT: When transporting the machine on a roadway, ALWAYS USE appropriate lamps and devices for adequate warning to operators of other vehicles.

Refer to [Use Safety Lights and Devices](#).

Replace Safety Signs

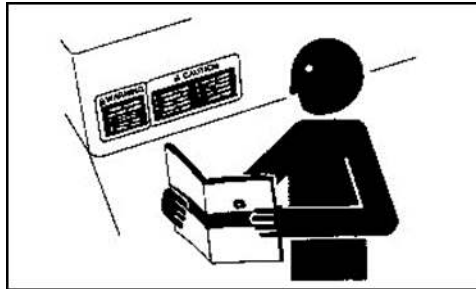

Replace missing or damaged safety signs. Use this Operator's Manual for correct safety sign placement.

There can be additional safety information contained on parts and components sourced from suppliers that is not reproduced in this Operator's Manual.

Wing

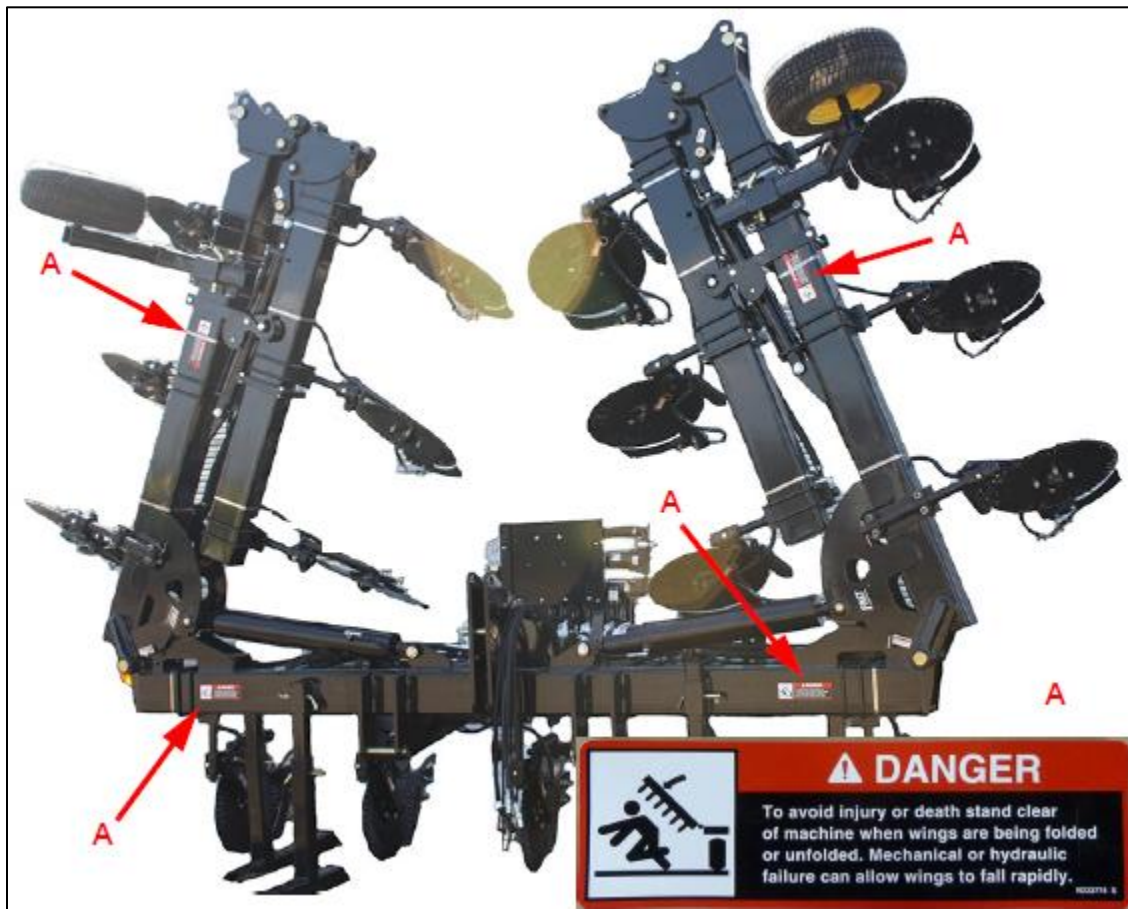

Safety Features



- A. Warning Lights
 - i. Alert other drivers to the machine's presence and width of slow-moving machinery on roadways and signal turns.
- B. Reflectors
 - i. Alert other drivers to the machine's presence and width of slow-moving machinery on roadways.

In addition to the safety features shown here, other components, systems, safety signs on the machine, safety messages, and instructions in the Operator's Manual contribute to the safe operation of this machine when combined with the care and concern of a capable Operator.

The construction of this implement may not meet all local or national requirements for transport on a public roadway. In regions or countries that have national certification requirements for roadway transport, it may be impossible for this implement to be approved for such roadway transport. The customer is responsible for understanding and complying with all local, regional, and national requirements regarding roadway transport.



Sign-Off Form

Fast Ag Solutions follows the general Safety Standards specified by the American Society of Agricultural Engineers (ASAE) and the Occupational Safety and Health Administration (OSHA). Anyone who will be operating and/or maintaining the FAST 3PT Applicator must read and clearly understand ALL Safety, Operating, and Maintenance information presented in this Manual.

Do not operate or allow anyone else to operate this equipment until such information has been reviewed. Annually review this information before season start-up.

A sign-off sheet is provided as a template for your records to show that all personnel who will be working with the equipment (Operators) have read and understand the information in this Manual and have been instructed in the safe operation, service, and maintenance of the equipment.

Date	Employee's Signature	Employer's Signature

SPECIFICATIONS

Tractor Power, Size Recommendation

Use the machine with a tractor providing drawbar power in the following ranges:

Model	Machine size, m (ft)	Tractor Power, kW (HP)
813P	18.3 (60)	112 (150)
833P	9.1 (30)	82 (110)
	12.2 (40)	97 (130)

Hydraulic System Requirements

A tractor hydraulic system with ISO hydraulic couplers is required.

Tractor Selective Control Valves (SCV) at the listed flowrates and pressure are required for following:

Circuit	SCV Function	Flowrate	Pressure
1	Main Lift Cylinders and Main Wing Down Pressure (Kick) Cylinders	19 LPM (5 GPM)	20684 kPa (206.8 bar) (3000 PSI)
2	Main Fold	45 LPM (12 GPM)	20684 kPa (206.8 bar) (3000 PSI)
3	Flip Fold	19 LPM (5 GPM)	20684 kPa (206.8 bar) (3000 PSI)
4	Chemical/Fertilizer Pump Drive Motor	30 LPM (8 GPM)	20684 kPa (206.8 bar) (3000 PSI)

Machine Dimensions & Specifications

Model	833P	813P
Transport Height	4.6 m (15 ft. 0 in.)	4.1 m (13 ft. 4 in.)
Transport Width	5.2 m (17 ft. 0 in.)	
Shipping Width	5.2 m (17 ft. 0 in.)	
Toolbar Size(s)	9.1 m (30 ft. 0 in.) - 12.2 m (40 ft. 0 in.)	18.3 m (60 ft. 0 in.)
Toolbar Tube Size	15.2 x 10.2 cm (6 x 4 in.)	17.8 x 17.8 cm (7 x 7 in.)
Weight, 23 coulters	3039 kg (6700 lbs.)	2313 kg (5100 lbs.)
Gauge Tires	20.5 x 8-10 (Standard), 6.7R15 (Optional)	
Crop Clearance	0.7 m (2 ft. 3.5 in.)	
Delivery Type	Injection or Knife	
Section Count	2	3
Standard Hydraulic Pump	ACE FMC-150-HYD-206	ACE FMCSC-205F-HYD-304
Hydraulic Down Pressure	Yes	
Hydraulic Wing Kick	Yes	

See [Checking Tire Pressure](#) for tire information.

PREPARING THE MACHINE

Use the Tractor Operator's Manual

Always refer to tractor operator's manual for specific detailed information regarding operation of equipment.



Break-In

See [TIGHTENING HARDWARE](#) for all torque values.

After **1 hour** of operation:

1. Tighten all wheel lugs.
2. Tighten all other fasteners and hardware to their required torque.
3. Check that no chemical or hydraulic lines are being pinched or crimped. Re-route as required.
4. Check that all coulters, nozzles, and placement components are clean and working properly. Clean as required.
5. Lubricate all grease fittings.

After **5 hours** of operation:

1. Tighten all wheel lugs.

After **10 hours** of operation:

1. Tighten all fasteners and hardware to their required torque.
2. Check chemical and hydraulic line routings.
3. Check that all placement components are clean and working properly.

After **50 hours** of operation:

1. Tighten all wheel lugs.
2. Then follow the normal servicing and maintenance schedule in [LUBRICATION & MAINTENANCE](#).

Pre-Operation Checklist

Efficient and safe operation of the machine requires that each Operator reads and understands operating procedures and all related safety precautions outlined in this section. A pre-operational checklist is provided for the Operator. It is important for both personal safety and maintaining the good mechanical condition of the Applicator that this checklist be followed.

Before operating the Applicator, check the following items:

1. Lubricate machine per the schedule outlined in the [LUBRICATION and MAINTENANCE](#) section.
2. Use only a tractor of adequate power and weight to operate the Applicator. See the [SPECIFICATIONS](#) section for recommendations.
3. Be sure that the machine is properly attached to the tractor. Be sure that all appropriate pins and retaining devices are installed.
4. Inspect all hydraulic lines, hoses, fittings, and couplers for tightness. See [Tightening Hardware](#) for break-in period recommendations.
5. Check tires and verify they are inflated to the specified pressure. See [Checking Tire Pressure](#)
6. Calibrate the Applicator if at the start of the season or a new applicator rate is being used.
7. Check the condition and routing of all fluid hoses and lines. Be sure that all lines are routed in large arcs. Replace any that are damaged. Re-route those that are rubbed, pinched, or crimped. See [Replace Hydraulic Hoses](#).
8. Check chemical application components. Remove and replace any that are worn.
9. Remove all entangled material.
10. Replace any plugged nozzles or tubes.

AXLES, TIRES, and TRACKS

Checking Tire Pressure

Check tire pressure and inflate as necessary.

⚠ CAUTION: Avoid loss of vehicle control during transport from failure of overloaded tires which could cause serious injury or death to you or others.

Equal pressure in all tires is necessary for even penetration. A low tire will cause deeper penetration on one side than the other. Increased penetration on one side will result in side-draft of the machine. Inflate tires to shown specification.

Tire Size	Pressure
20.5 x 8-10	621 kPa (6.21 bar) (90 PSI)
6.7R15	303 kPa (3.03 bar) (44 PSI)

Checking Wheel Nuts

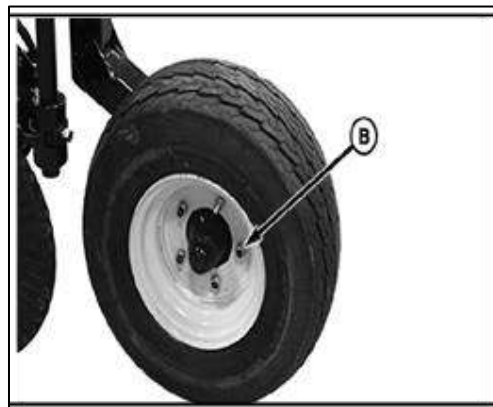

B. Gauge Wheel Nut

Check tightness of all wheel nuts (B) during the first week of operation and periodically after that.

Tighten all wheel bolts to specification.

Item	Specification
(B) Gauge Wheel Nut	95 N-m (70 ft-lbs.)

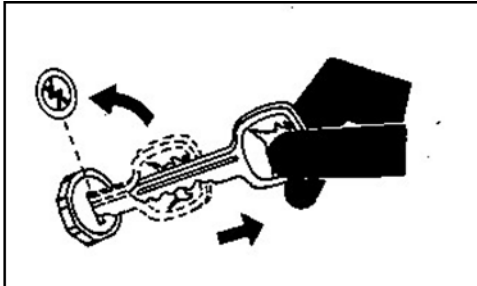
ATTACHING and DETACHING**Attach the Machine Safely**

- ⚠ **CAUTION:** Prevent personal injury caused by unexpected movement of the machine. Engage the tractor's parking brake and/or place transmission in **PARK**, shut off the engine, and remove the ignition key before working around the hitch.

Attach the Machine to the Tractor

- ⚠ **CAUTION:** Make sure that all bystanders are clear of the working area.
1. Make sure there is enough room and clearance to safely back up to the machine.
 2. Slowly back the tractor until holes on the hitch and 3PT Hitch arms are aligned.
 3. Install 3PT pins and retainer.
 4. Check that the Applicator hydraulic system is compatible with the tractor's hydraulics: [Hydraulic System Requirements](#). Change the choice of the Applicator model if required. Do not operate unless tractor and implement hydraulics are compatible.
 5. Connect Hydraulics



- ⚠ **WARNING:** Prevent serious injury or death. Relieve hydraulic system pressure before connecting hydraulic hoses.
- a. Use a clean rag or paper towel to clean dirt from couplers on hose ends and tractor couplers.
 - b. Relieve pressure in the hydraulic system.
 - c. Route hoses over the hitch and connect hoses to tractor couplers. Verify couplers are securely seated. See [SCV Identification Chart](#) for hose connections.
 - d. Be sure to provide slack for turning.
6. Route electrical lines over the hitch and connect to the tractor's electrical connectors.

Attach Warning Light Plug

- ⚠ **CAUTION:** When transporting the machine on a road or highway at night or during the day, use warning lights and devices for adequate warning to operators of other vehicles. For this matter, check local governmental regulations.

Various safety lights and devices are available from your Fast Ag Solutions dealer.

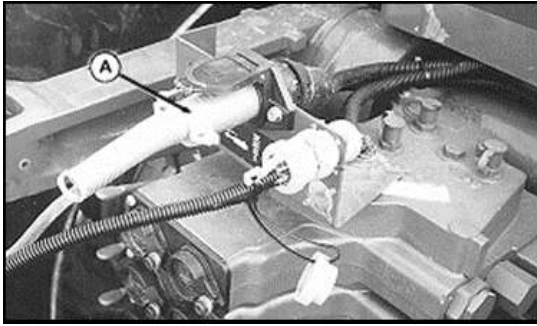

A. 7-Pin Connector Warning Light Plug

Attach a warning light plug (A) to the tractor's outlet socket.

Be sure warning lights, reflectors, and SMV emblem(s) are clean.

Connect Rate Controller or Nutrient Applicator System Wiring

See manufacturer's Manuals for connecting controller cables to the tractor.

Make Proper Hose Connections



⚠ WARNING: Escaping fluid under pressure can penetrate the skin and cause serious injury. Avoid the hazard by relieving pressure before disconnecting any hydraulic or other pressurized lines. Tighten all connections before applying pressure. Search for leaks with a piece of cardboard. Protect hands and body from high-pressure fluids.

⚠ WARNING: Prevent serious injury or death. Relieve hydraulic system

pressure before disconnecting hydraulic hoses.

If an accident occurs, see a doctor immediately. Any fluid injected in the skin must be surgically removed within a few hours or gangrene may result. Doctors unfamiliar with this type of injury should reference a knowledgeable medical source. Such information is available from Deere & Company Medical Department in Moline, Illinois, U.S.A.

⚠ IMPORTANT: Hydraulic hoses can fail due to physical damage, kinks, age, and exposure. Check hoses regularly. Replace damaged hoses.

⚠ IMPORTANT: All hydraulic couplers must be clear of debris, dust, and sand. Use protective caps on fluid openings until ready to make connection. Foreign material can damage the hydraulic system.



A. SCV Marker
B. Hose Key Chart

Identify the SCV marker color (A) and then use the hose key chart (B) to connect to the correct SCV outlet. (See [SCV Identification Chart](#))

Make sure the quick couplers are fully engaged. If the quick couplers do not fully engage, check to see that the couplers are the same size and type.

SCV Identification Chart

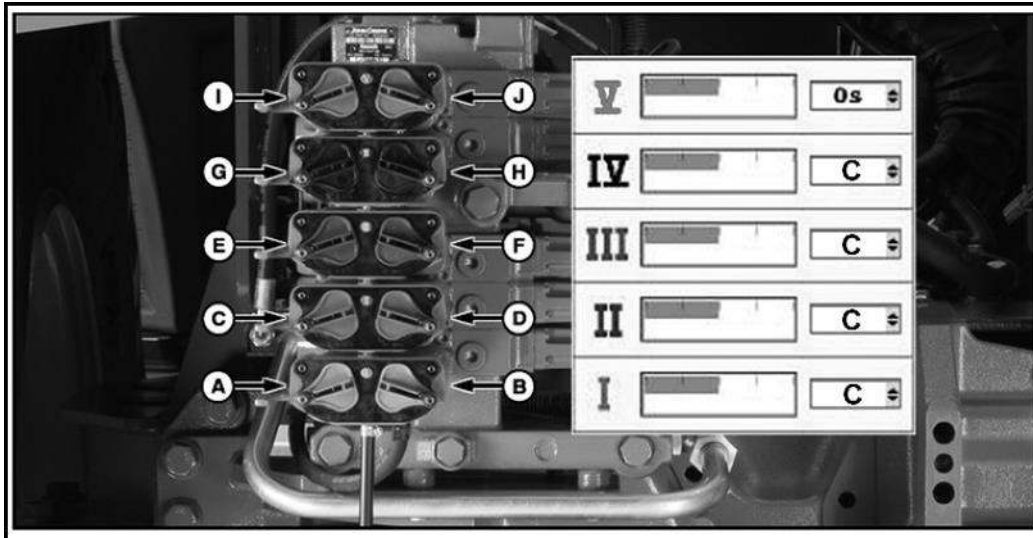

Legend	SCV ID	Tractor Flow Type	Hose Color	SCV Function
A	I	Return	Gray	Wing Kick (Rod End)
B	I	Pressure	Orange	Wing Kick (Base End)
C	II	Return	Green	Main Fold (Rod End)
D	II	Pressure	Blue	Main Fold (Base End) const. flow
E	III	Return	Brown	Flip Fold (Rod End)
F	III	Pressure	Purple	Flip Fold (Base End)
G	IV	Return	Yellow	Product Pump Return
H	IV	Pressure	Red	Product Pump Pressure
I	V	Return	Black	-
J	V	Pressure	White	-

▲ IMPORTANT: Hose colors do not match SCV color

See [Hydraulic System Requirements](#) for system compatibility.

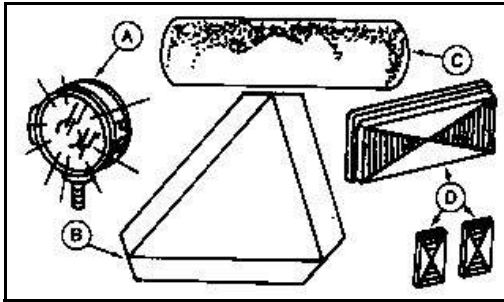
TRANSPORTING**Following Safe Transport Procedures**

- A. Lights
- B. SMV Emblem
- C. Reflector Tape
- D. Reflectors

⚠ CAUTION: When transporting the machine on a road or highway at night or during the day, use warning lights and devices for adequate warning to operators of other vehicles.

Check local governmental regulations.

Various safety devices are available from your Fast Ag Solutions dealer. Keep safety items in good condition. Replace missing or damaged items.

Upward force on hitch may cause instability when transporting. Add BALLAST to tractor as required.

BEWARE of overhead wires and narrow gates. KNOW the transport height and width of your machine. (See [Machine Dimensions & Specifications](#).)

Travel at a reasonable and safe speed; REDUCE speed over rough or uneven terrain, slopes, and when turning. See [Observe Maximum Transport Speed](#).

BE SURE SMV emblem, reflectors, and warning lights are clean, visible, and in good condition.

Preparing the Machine for Transport

- ⚠ CAUTION: Be sure all bystanders are clear of the Applicator.**
- ⚠ CAUTION: See [Observe Maximum Transport Speed](#) in the Safety section for towing information.**

Fold Toolbar for Transport

1. Remove the main wing lock pins from their field position (833P only.)
2. Raise the 3PT Hitch.
3. Pull SCV I backward to raise the kick wings up.
4. Pull SCV III backward to fully retract the flip wings.
5. Pull SCV II backward to fully retract the main wings.
6. Install the main wing lock pins in their transport position (833P only.)
7. Toolbar is in transport position.

Transport Notes and Checks

Be sure that the Applicator is properly connected to the tractor. Always attach a safety chain between the Applicator and the tractor and install a retainer through the 3PT Hitch.

Ensure that the hitch latch is fully engaged.

- ⚠ IMPORTANT: Gauge wheels may need to be reversed to meet transport width requirements.**

Transporting the Machine

Using Warning Lights

⚠ CAUTION: When transporting the machine on a road or highway at night or during the day, use accessory lights and devices for adequate warning to operators of other vehicles. Check local governmental regulations.

Various safety lights and devices are available from Fast Ag Solutions dealer. Keep safety items in good condition. Replace missing or damaged items.

During periods of limited visibility, use pilot vehicles and use extra lights on the machine.

During normal transport, both amber warning lights will flash in unison at high intensity and both red lamps will illuminate steadily at low intensity.

When a turn is signaled, red and amber tail lamps in the direction of turn will flash at high intensity and in unison. On the opposite side, amber and red lamps will illuminate steadily at high intensity.

Keep Riders Off the Machine

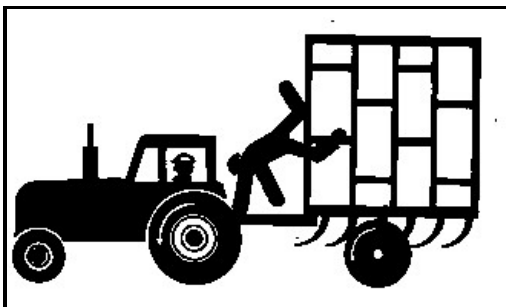

Riders are subject to injury such as being struck by foreign objects and being thrown off the machine. Riders obstruct the Operator's view resulting in the machine being operated in an unsafe manner.

Caution for All Machines

⚠ CAUTION: When transporting the machine on a smooth surface road, do not exceed the maximum transport speed of 32 km/h (20 MPH). Reduce speed considerably when traveling over rough ground.



Reduce speed when turning. Do not uncouple tractor brake pedals and apply individually in an attempt to make a tighter turn.



Serious injury or death can result from contact with electric lines. Use care when moving or operating this machine near electric lines to avoid contact. Know transport height and width of machine. Check local regulations before transporting. (See [Machine Dimensions & Specifications](#) for transport height and width of machine.)

Transport with wings fully folded. Never raise or lower the center section or wings when moving. After folding, ALWAYS place the fold valve(s) in the neutral position for transport.

If wing-fold cylinders are removed or damaged, chain wings together to prevent injury or death caused by accidental falling of wings on you or others.

Unfolding/Extending the Toolbar



⚠ WARNING: Prevent serious injury or death. The machine coming near or contacting power lines can cause electrocution. Electrocution can occur without contact. Fully lower wings before moving or transporting.

1. Remove main wing lock pins (833P only.)
2. Pull SCV I backward to raise the center section and inner wings.
3. Verify tool bar is fully raised.
4. Push SCV II forward to fully extend the main wings' cylinders.
5. Put SCV II in float. The main wings will remain "kicked up" until SCV I is activated to lower them during field operation.
6. Push SCV III to extend the flip wings' cylinders to full extension.
7. Install the main win lock pins (833P only) in their field position.
8. Toolbar is in field position.

Field Operation Notes

⚠ IMPORTANT: Check that SCV I is providing hydraulic fluid to the down pressure (kick) circuit

Failure to keep SCV I engaged and supplying a constant oil flow to the down pressure system will result in coulters riding out of the ground and could result in structural failure of the toolbar and/or hydraulic cylinder components.

⚠ IMPORTANT: Check that SCV II is in the float position.

Failure to allow the main wings to freely extend and retract as needed for changing ground contours will put undue stress on the toolbar structure and folding mechanism.

Use the 3PT Hitch remote in conjunction with SCV I to lower the coulters into the ground. The timing of motion must be right to have main wing coulters touch down when lowering (or exit when raising) at the same time as all other coulters. This will permit them to enter/exit the ground at a near vertical angle.

Outer Wing of 40' Machines

Chemical lines to the outer wings have a valve to shut off flow to the flip wings. Turn valves (E) off to get a 30' application width. Open the valves when the narrow requirements are finished.

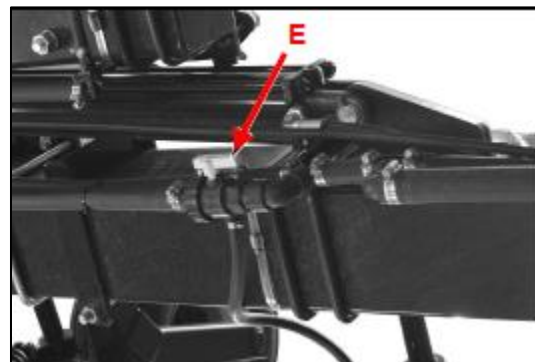
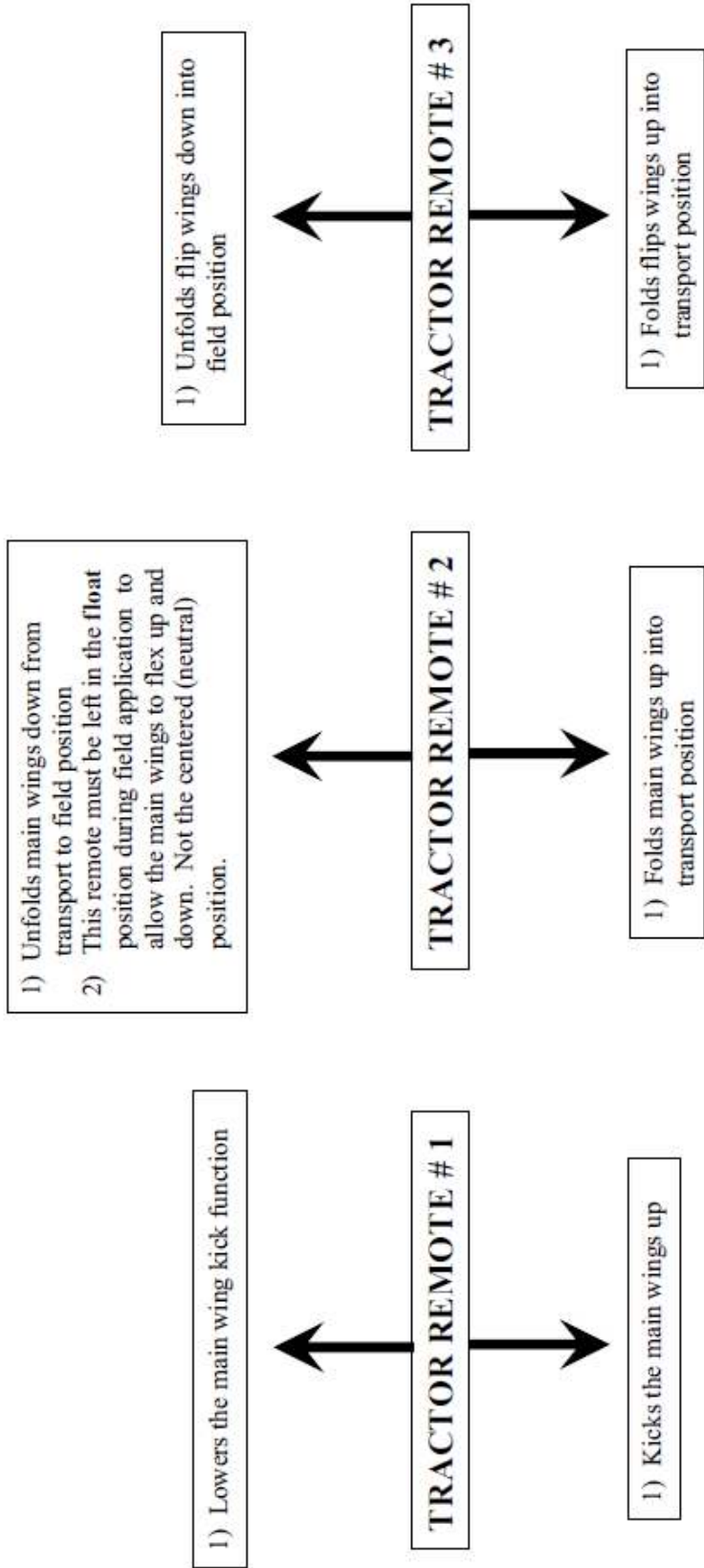

Figure 2: Flip Wing shutoff valve, right side

HYDRAULIC FLOW

813P AND 833P DOUBLE BAR TRACTOR REMOTE FUNCTIONS

Quick Reference Sheet



Regulating Hydraulic Flow to the Pump

Locate your tractor model and follow the appropriate setup instructions.

⚠ WARNING: FAILURE TO REGULATE OIL FLOW WILL CAUSE MOTOR FAILURE.

⚠ WARNING: NOT SUITABLE FOR PUMPING FLAMMABLE LIQUIDS.

Load Sensing Closed Center System (LS Closed)

Regulate oil flow with the tractor's FLOW CONTROL and FLOW LIMITER. (Do not use restrictor orifice.)

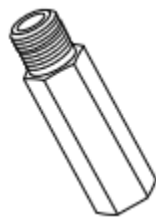

Figure 3: Flow Limiter



Figure 4: Flow Control

Setup Instructions:

1. (Optional) Remove adapter and install flow limiter in motor inlet port (marked I).
2. Close motor needle valve: loosen jam nut, screw needle valve clockwise until seated, and lock jam nut (factory setting.)
3. Shut off toolbar boom and agitation valves if equipped.
4. Adjust tractor flow control to minimum flow setting (Turtle).
5. Move hydraulic lever to "Lower/Retract" position to start pump.

6. Adjust tractor flow control until the toolbar shut-off (deadhead) pressure is within the pump's operating parameters. **Note:** If the flow limiter stops oil flow to the motor:
 - a. Move hydraulic lever to "Float" or "Neutral" to remove oil pressure from the flow limiter.
 - b. Adjust tractor flow control to a lower flow position.
7. Repeat steps 5 and 6.
8. Open the agitation valve(s).

Pressure Compensating Closed-Center System (PC Closed)

Regulate oil flow by using a RESTRICTOR ORIFICE. (Do not use flow limiter.)

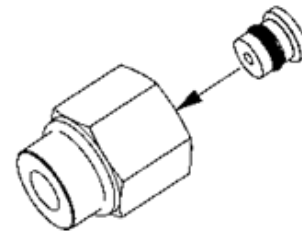

Figure 5: Restrictor Orifice

Setup Instructions:

1. Install restrictor orifice by inserting inside the adapter/restrictor body in the motor inlet port (marked I).
2. Close motor needle valve: loosen jam nut, screw needle valve clockwise until seated, and lock jam nut (factory setting.)
3. Set "Rabbit/Turtle" flow control to "Turtle".
4. Move hydraulic lever to the "Lower/Retract" position to start pump.
5. Adjust "Rabbit/Turtle" flow control and agitation valve(s) to get desired injection pressure.

Open Center System (Open)

Select motor size closest to tractor's hydraulic system capacity. Regulate oil flow with motor NEEDLE VALVE.

(Do not use restrictor orifice or flow limiter.)

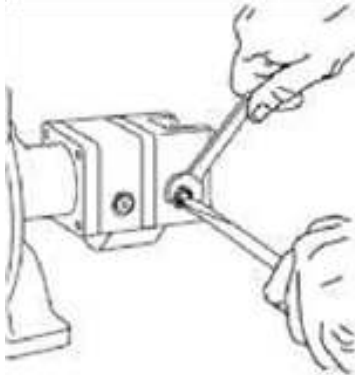

Figure 6: Closing the Needle Valve

Setup Instructions:

1. Shut off all chemical/product supply valves.
2. Loosen jam nut on motor and back out needle valve 3 or 4 turns counterclockwise.
3. Set tractor throttle to sprayer operating speed.
4. Move hydraulic lever to "Lower/Retract" position to start pump.
5. Screw needle valve clockwise until sprayer (deadhead) pressure is within the pump's operating parameters and lock the jam nut.
6. Open the sprayer agitation valve to get desired injection pressure.

Tractor SCV Functions

See [SCV Identification Chart](#) for connections.

▲ NOTE: The illustrations in this Manual are for explanatory purposes only. Your control system may differ in appearance and function.

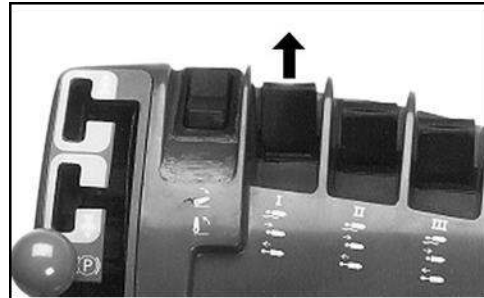

Figure 7: SCV I Pushed Forward

When the tractor's SCV I is pushed forward, the following functions are enabled:

1. Lowers main wing kicks.

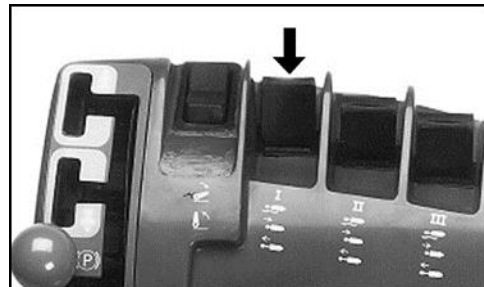

Figure 8: SCVI Pulled Backward

When the tractor's SCV I is pulled backward, the following functions are enabled:

1. Raises main wing kicks.

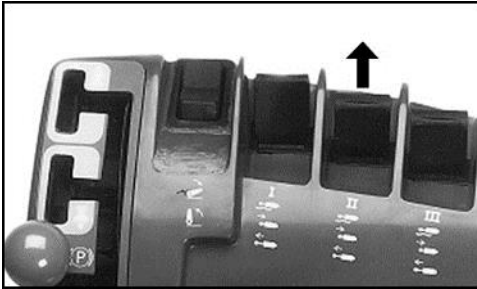

Figure 9: SCV II Pushed Forward

When the tractor's SCV II is pushed forward, the following functions are enabled:

1. Unfolds main wings.

▲ IMPORTANT: The SCV II function must be left in float (not neutral) whenever the toolbar is in the ground to allow the toolbar to flex.

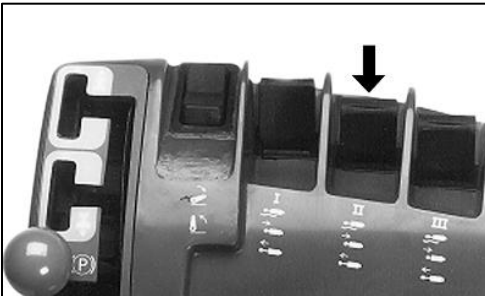

Figure 10: SCV II Pulled Backward

When the tractor's SCV II is pulled backward, the following functions are enabled:

1. Folds flip wings.



Figure 11: SCV III Pushed Forward

When the tractor's SCV III is pushed forward, the following functions are enabled:

1. Unfolds flip wings.

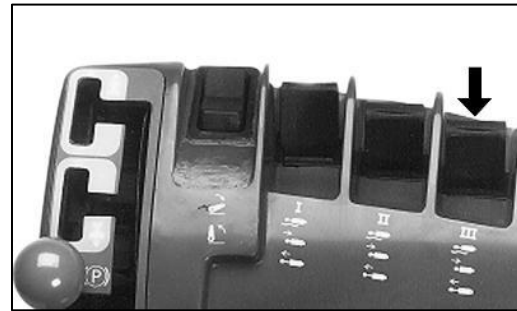

Figure 12: SCV III Pulled Backward

When the tractor's SCV III is pulled backward, the following functions are enabled:

1. Folds main wings.



Figure 13: SCV IV Pushed Forward

When the tractor's SCV IV is pushed forward, the following functions are enabled:

1. Engages product pump.



Figure 14: SCV IV Pulled Backward

When the tractor's SCV IV is pulled backward, the following functions are enabled:

1. Disengages product pump.

ADJUST DEPTH CONTROL

Adjust Application Depth

Depth of material placement can vary depending on the type of application. Check with the fertilizer or chemical manufacturer for information regarding application depth. Set toolbar, coulter/disc, row unit, or nozzle to required depth.

Once the desired field location of the application is reached, the center section and main wing kick may be lowered.

Even after row units are in ground, the SCV switch for Down Pressure must be constantly engaged to provide oil supply to and drain from down pressure circuit.

Failure to keep Down Pressure engaged and constant supply of oil flow to the down pressure system may result in coulters riding out of the ground and could result in structural failure of the toolbar and/or hydraulic cylinder components.

Down Pressure Adjustment

The extension rate of the down pressure (kick) cylinders can be adjusted via an adjustable pressure valve.

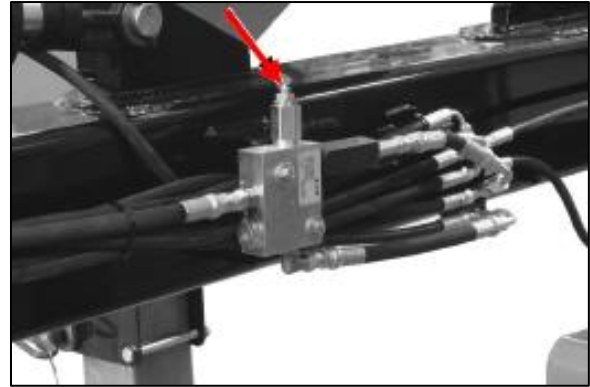

Adjustment should be made on this valve when ground conditions change significantly.

1. Verify that the main lift hydraulic flow setting in the tractor is set to 9 or 90%.
2. Unfold the toolbar into its field position and lower the toolbar fully to the ground.
3. Keep the main wings' switch (SCV II) engaged.
4. Loosen the jam nut on the valve.
5. Using an Allen wrench, turn the socket head screw in $\frac{1}{4}$ -turn increments to adjust the down pressure.
 - a. Turn clockwise to increase pressure, and
 - b. Turn counterclockwise to decrease pressure.
6. **The hydraulic down pressure gauge should read between 700 PSI and 1500 PSI.**
7. Tighten the jam nuts when finished.
8. Raise the toolbar fully.
9. Toolbar is ready for application.

Use only as much down pressure as needed to get coulters to their proper depth. Excess pressure could cause damage to the toolbar.

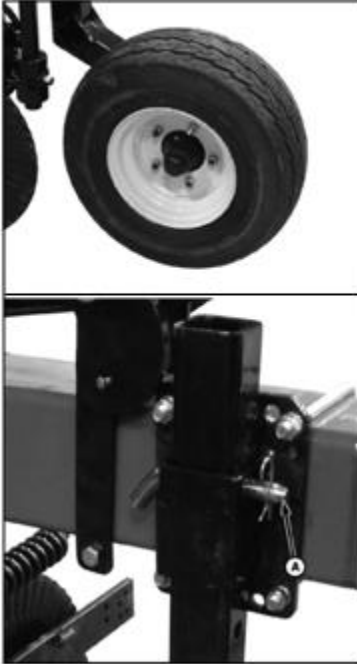
Adjust Gauge Wheels

A. Pin

Each main wing is equipped with a gauge wheel that helps to maintain the application depth. Lower the gauge wheels if soil conditions are soft and raise if they are hard to obtain the same application depth.

1. Remove pin (A) and adjust gauge wheel height as desired.
2. Install pin and lock pin.
3. Repeat for the other side.

ADJUST GROUND SPEED

It will be necessary to establish a travel speed and then set the flow to give the desired application rate. Always run at the established travel speed.

However, the best results are obtained when the ground speed is 8 - 13 kph (5 - 8 mph). Ground speed variations in the field will automatically be compensated.

Always operate at a comfortable speed. Do not operate so quickly that the toolbar bounces while going through the field.

Effective results require that liquid be applied at a consistent depth in a consistent manner. Machine bouncing will prevent this required consistency.

ADJUST NOZZLES

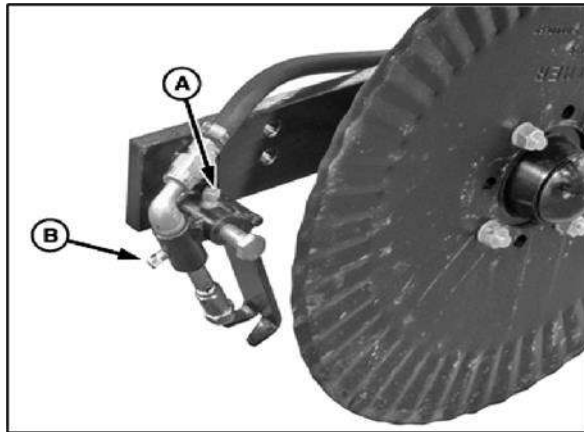

- A. Setscrew
- B. Setscrew

1. Extend the wings and raise the toolbar to its fully up position.
2. Place safety stands under the center of the toolbar or install cylinder transport locks on the lift cylinders.
3. To adjust nozzle angle:
 - a. The best results are obtained when the nozzle directs liquid approximately 1 inch (25 mm) behind the coulter.
 - b. Loosen setscrew (A) to set the nozzle at the required angle and centered behind the coulter.
4. To adjust nozzle spray pattern:
 - a. Sight along the nozzle and coulter. The nozzle should direct liquid directly behind the coulter.
 - b. Loosen setscrew (B) to adjust the nozzle spray parallel with a furrow.
5. As a general guideline, the tip of the nozzle should be slightly above the ground as the unit moves over the field. This will ensure that liquid enters the soil via a furrow and is retained in the soil as the furrow closes.

Clean the liquid system filter at the start of each day or when dirt is detected in the system. See [Clean Strainer Filter](#).



Check chemical or fertilizer M/SDS for proper handling instructions.

Toxic chemicals can enter the body by breathing spray or contact with bare skin.

Do not take a chance with your health and safety.

Adjust Knives

If equipped, the gap between the knife tip and the blade should be .26" (6.6mm). After the knife is properly adjusted, spin the blade to ensure the knife misses the blade, adjust as necessary.

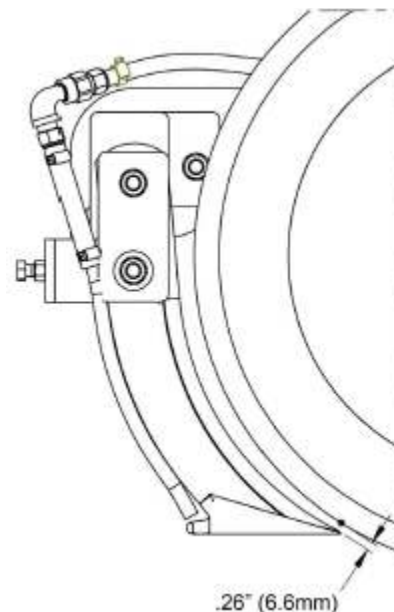

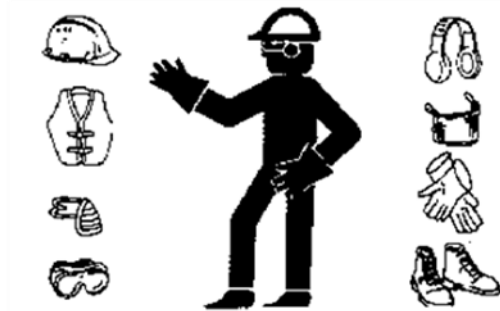
PREPARING THE LIQUID SYSTEM

⚠ CAUTION: Prevent serious injury or death

Check the chemical or fertilizer M/SDS for proper handling instructions.

Toxic chemicals can enter the body by breathing spray or contact with bare skin.

Do not take a chance with your health and safety.

⚠ IMPORTANT: Do not run the pump dry - damage may occur.

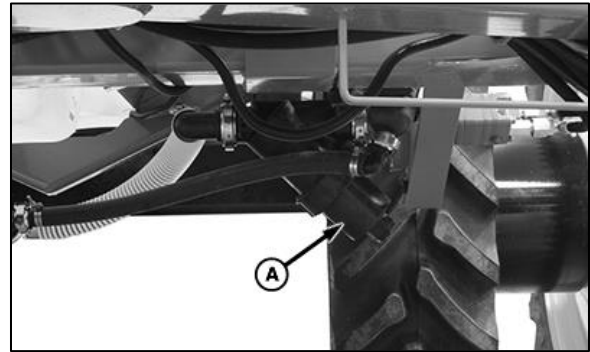
Clean Strainer Filter

A. Screen

The liquid system is equipped with a screen (A) in its suction line to remove dirt and impurities.

Clean the filter at the start of each day or when dirt is detected in the system.

1. Clear area of bystanders.
2. Close the liquid supply valve.
3. Remove the cap to access the screen.
4. Use clear water to clean the screen.

⚠ IMPORTANT: Do not over tighten the canister and crack its head.

5. Install the screen in the canister and tighten by hand.
6. Open the liquid supply valve.

LUBRICATION & MAINTENANCE

Lubricating and Maintaining the Machine Safely

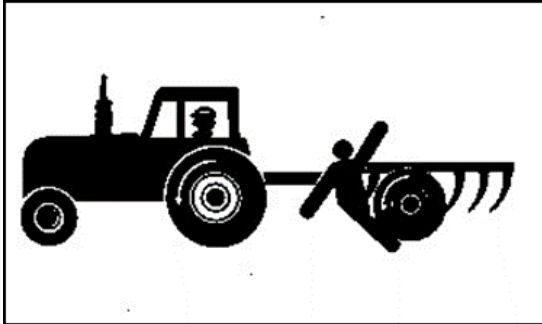

⚠ CAUTION: To help prevent serious injury or death to you or others caused by unexpected movement, be sure to service machine on a level surface.

If the machine is connected to a tractor, engage the tractor's parking brake, place the tractor's transmission in PARK, shut off the engine, and remove its key. If the machine is detached from the tractor, block wheels and use safety stands to prevent movement.

Lubricant Storage

Equipment can operate at top efficiency only when clean lubricants are used.

Use clean containers to handle all lubricants.

Whenever possible, store lubricants and containers in an area protected from dust, moisture, and other contamination. Store containers on their side to avoid water and dirt accumulation.

Make certain all containers are properly marked to identify their contents.

Properly dispose of all old containers and any residual lubricant they may contain.

Grease

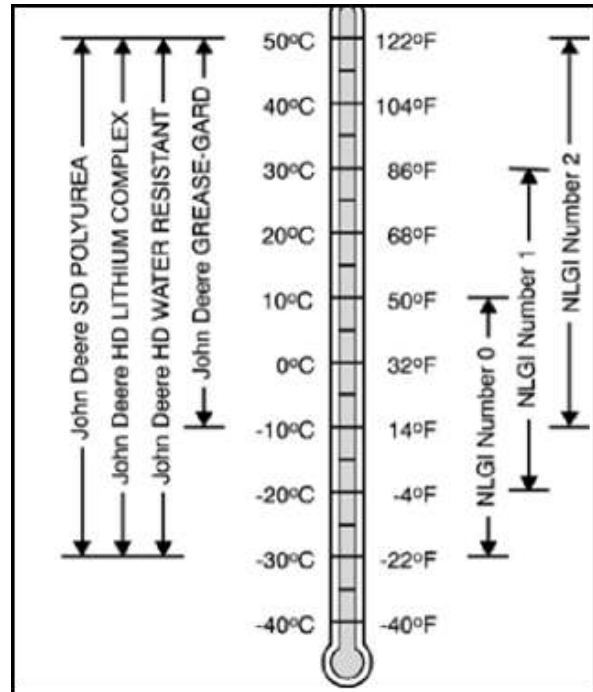

Greases for Air Temperature Ranges

Use grease based on NLGI consistency numbers and the expected air temperature range during the service interval.

⚠ IMPORTANT: Some types of grease thickeners are not compatible with others. Consult your grease supplier before mixing different types of grease.

Alternative and Synthetic Lubricants

Conditions in certain geographical areas may require lubricant recommendations different from those printed in this Manual. Synthetic lubricants may be used if they meet the performance requirements as shown in this Manual.

The temperature limits and service intervals shown in this Manual apply to both conventional and synthetic lubricants.

Re-refined base stock products may be used if the finished lubricant meets the performance requirements.

Lubrication and Maintenance Intervals

Perform each lubrication and service illustrated in this section.

Wipe the implements' grease fittings with a clean cloth before greasing to avoid injecting dirt or debris. Replace broken fittings immediately.

If a fitting will not accept grease, remove and clean it thoroughly or replace it. Clean the passageway.

Each 10 hours or Daily

- Clean the Strainer
 - It is recommended that the fertilizer strainer screen be removed and washed with clean freshwater every 8 hours.



- Grease the Inner Wing Lift Cylinders
- Grease the Inner Wing Lift Pins
- Grease the Coulter hubs.



- Grease the Gauge Wheels



Each 50 Hours or Weekly

- Grease the Flip Wing Fold Hinges (both sides)

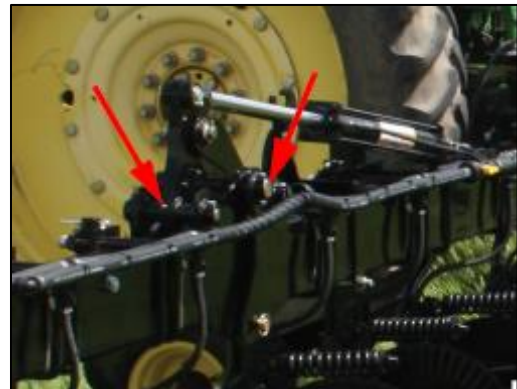

- Grease the Main Wing Fold Hinges (both sides)

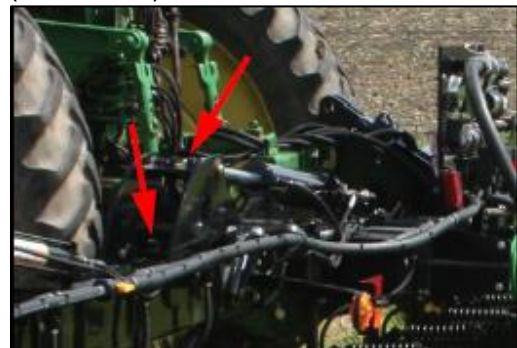

SERVICE**Practice Safe Maintenance**

Understand all service procedures before doing work. Keep the area clean and dry.

Never lubricate, service, or adjust the machine while it is moving. Keep hands, feet, and clothing away from power-driven parts. Disengage all power and operate controls to relieve pressure. Lower equipment to the ground. Stop the engine. Remove the key. Allow the machine to cool. Securely support any machine elements that must be raised for service work.

Keep all parts in good condition and properly installed. Fix any damage immediately. Replace worn or broken parts. Remove any buildup of grease, oil, or debris.

On self-propelled equipment, disconnect the battery ground cable (-) before making adjustments on any electrical systems or welding on the machine.

On towed implements, disconnect its wiring harnesses from the tractor before servicing any electrical system components or welding on the machine.

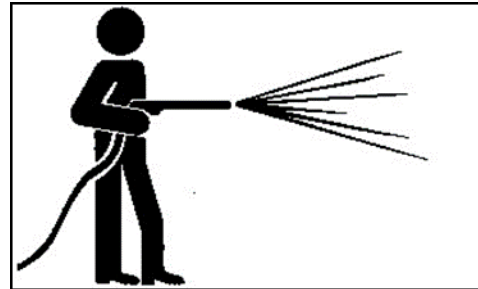
Work in a Clean Area

Before starting a job:

- Clean the work area and the machine.
- Make sure you have all the necessary tools to do your job.
- Have the right parts on-hand.
- Read all instructions thoroughly; do not attempt shortcuts.

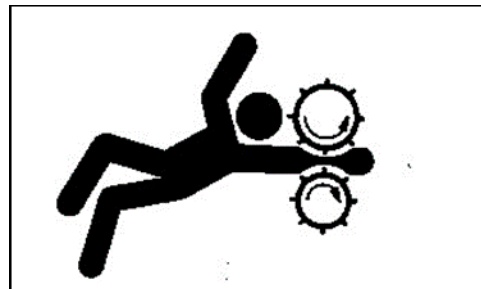
Service Machines Safely

Tie long hair behind your head. Do not wear a necktie, scarf, loose clothing, or necklace when you work near machine tools or moving parts. If these items were to get caught, severe injury could result.

Remove rings and other jewelry to prevent electrical shorts and entanglement in moving parts.

Support the Machine Properly



Always lower the attachment or implement to the ground before you work on the machine. If the work requires that the machine or attachment be lifted, provide secure support for them. If left in a raised position, hydraulically supported devices can settle or leak down.

Do not support the machine on cinder blocks, hollow tiles, or props that may crumble under continuous load. Do not work under a machine that is supported solely by a jack. Follow the recommended procedures in this Manual.

When implements or attachments are used with a machine, always follow safety precautions listed in the implement or attachment's Operator's Manual.

Avoid High-Pressure Fluids



Inspect hydraulic hoses periodically – at least once per year – for leakage, kinking, cuts, cracks, abrasion, blisters, corrosion, exposed wire braids, or any other signs of wear or damage.

Replace worn or damaged hose assemblies immediately with Fast Ag Solutions approved replacement parts.

Escaping fluid under pressure can penetrate the skin causing serious injury. Avoid the hazard by relieving pressure before disconnecting hydraulic or other lines. Tighten all connections before applying pressure.

Search for leaks with a piece of cardboard. Protect hands and body from high-pressure fluids.

If an accident occurs, see a doctor immediately. Any fluid injected into the skin must be surgically removed within a few hours or gangrene may result. Doctors unfamiliar with this type of injury should reference a knowledgeable medical source.

Preventing Hydraulic System Contamination

▲ IMPORTANT: Cleanliness is very important when working on a hydraulic system. Prevent contamination by assembling cylinders, hoses, couplers, and valves in a clean area of the shop.

Leave protective caps on fluid openings until you are ready to make a connection. When charging the system, use a tractor or other source that contains clean oil free of abrasive materials.

Keep couplers clean. Abrasive particles, like sand or metal fragments, can damage seals, barrels, and pistons causing internal leakage.

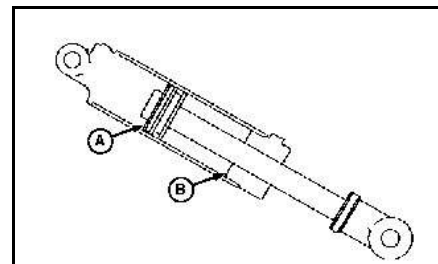

- A. Piston
- B. Rod Guide or Gland

- ▲ **IMPORTANT:** To help keep couplers clean, always place them in a storage position when they are not attached to the tractor.
- ▲ **IMPORTANT:** To prevent contaminants from entering the hydraulic system, filters must be installed at the tip of a supply hose. Additional filters are not recommended as they will restrict oil flow and adversely affect cylinder actuation time due to pressure drop.

Without a filter, large dirt particles can enter the cylinder and settle against the top side of piston (A) where they can cut the piston seal as the cylinder retracts.

Replace Hydraulic Hoses

- ▲ **WARNING:** Avoid hazards due to escaping fluid under pressure. See [Avoid High-Pressure Fluids](#).

Hydraulic hoses between the lift cylinders and hydraulic lock-up valve should be inspected frequently for leakage, kinking, cuts, cracks, abrasion, blisters, corrosion, exposed wire braids, or any other signs of wear or damage.

Worn or damaged hose assemblies can fail during use and should be replaced immediately.

See your Fast Ag Solutions dealer for replacement hoses.

- ▲ **CAUTION:** If an incorrectly rated hose is used, machine damage, injury, or death could occur.

If hoses are to be fabricated, ensure that the hoses are rated at no less than 82,737 kPa (827 bar) (12,000 psi) burst pressure according to SAE Standard J517, 100R17 hose specification.

Incorrect hose length or routing can increase the chance of hose wear or damage. Use the

old hose as a guide for length and hose routing.

Incorrect fittings can damage mating parts or cause leaks. Make sure to use steel fittings approved for use by the hose's manufacturer. Use the correct size and thread.

Make sure hydraulic hoses and harnesses do not interfere with moving parts. Relocate hoses and harnesses and retain them with clamps.

Tightening Hardware

Tighten all bolts to torques specified in [TIGHTENING HARDWARE](#) section unless otherwise noted.

Check tightness of hardware periodically.

PREPARING FOR STORAGE

⚠ CAUTION: Store the unit in an area away from human activity. Do not permit children to play on or around the stored Applicator.

At the end of the season, thoroughly inspect and prepare the Applicator for storage. Repair or replace any worn or damaged components to prevent any unnecessary downtime at the beginning of next season.

1. Select an area that is dry, level, and free of debris.
2. Move the machine into its transport position. See [Fold Toolbar for Transport](#).
3. Secure the (4) parking stands to the toolbar's center section stake pockets.
4. Relieve the hydraulic system of any residual pressure.
5. Using the 3PT Hitch, lower the center section with parking stands down to the ground.
6. Unhook the Applicator from the tractor.
7. Thoroughly wash the machine using a pressure washer to remove all dirt, mud, debris, and residue to protect against corrosion.
8. Lubricate all grease points. Make sure all grease cavities have been filled with grease to remove any water residue from washing.
9. Inspect all hydraulic hoses, couplers, and fittings. Tighten any loose fittings. Replace any hose that is damaged or is separating from the crimped end of a fitting.
10. Inspect all liquid lines and connections. Tighten any loose fittings. Replace any line that is cut, nicked, or abraded.
11. Touch up all paint nicks and scratches to prevent rusting.

Removing from Storage

1. Clear the area of bystanders, especially small children, and remove foreign objects from the machine and working area.
2. Attach the tractor to the Applicator.
3. Check:
 - a. Attach and secure all liquid lines.
 - b. Row Units and Nozzles.
 - c. All hardware. Tighten as required.
 - d. Tire pressure.
 - e. All hydraulic lines, fittings, and connections. Tighten as required.
4. Lubricate all grease fittings.
5. Replace any defective parts.
6. Add a small amount of liquid to the system. Turn the product pump on momentarily and check that liquid comes out of each nozzle/injector.
7. Follow the [Pre-Operation Checklist](#) before using.

TIGHTENING HARDWARE

Check the tightness of ALL BOLTS, U-BOLTS, and CAP SCREWS after the first 10-15 hours of operation and again at end of the first week (50 hours) of operation. Tighten all bolts to torques specified unless otherwise noted. Check tightness of hardware periodically.

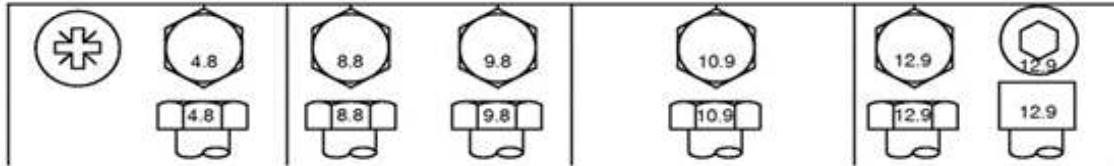

Figure 15: Common metric bolt grade markings

Metric Bolt and Screw Torque Values

Screw Size	Class 4.8				Class 8.8 or 9.8				Class 10.9				Class 12.9			
	Lubricated ¹		Dry ²		Lubricated ¹		Dry ²		Lubricated ¹		Dry ²		Lubricated ¹		Dry ²	
	N-m	lb.-in.	N-m	lb.-in.	N-m	lb.-in.	N-m	lb.-in.	N-m	lb.-in.	N-m	lb.-in.	N-m	lb.-in.	N-m	lb.-in.
M6	4.7	42	6	53	8.9	79	11.3	100	13	115	16.5	146	15.5	137	19.5	172
									N-m	lb.-ft.	N-m	lb.-ft.	N-m	lb.-ft.	N-m	lb.-ft.
M8	11.5	102	14.5	128	22	194	27.5	243	32	23.5	40	29.5	37	27.5	47	35
			N-m	lb.-ft.	N-m	lb.-ft.	N-m	lb.-ft.								
M10	23	204	29	21	43	32	55	40	63	46	80	59	75	55	95	70
	N-m	lb.-ft.														
M12	40	29.5	50	37	75	55	95	70	110	80	140	105	130	95	165	120
M14	63	46	80	59	120	88	150	110	175	130	220	165	205	150	260	190
M16	100	74	125	92	190	140	240	175	275	200	350	255	320	235	400	300
M18	135	100	170	125	265	195	330	245	375	275	475	350	440	325	560	410
M20	190	140	245	180	375	275	475	350	530	390	675	500	625	460	790	580
M22	265	195	330	245	510	375	650	480	725	535	920	680	850	625	1080	800
M24	330	245	425	315	650	480	820	600	920	680	1150	850	1080	800	1350	1000
M27	490	360	625	460	950	700	1200	885	1350	1000	1700	1250	1580	1160	2000	1475
M30	660	490	850	625	1290	950	1630	1200	1850	1350	2300	1700	2140	1580	2700	2000
M33	900	665	1150	850	1750	1300	2200	1625	2500	1850	3150	2325	2900	2150	3700	2730
M36	1150	850	1450	1075	2250	1650	2850	2100	3200	2350	4050	3000	3750	2770	4750	3500

Torque values listed are for general use only, based on the strength of the bolt or screw. DO NOT use these values if a different torque value or tightening procedure is given for a specific application. For stainless steel fasteners or for nuts on U-bolts, see the tightening instructions for the specific application. Tighten plastic insert or crimped steel type lock nuts by turning the nut to the dry torque shown in the chart, unless different instructions are given for the specific application.

Shear bolts are designed to fail under predetermined loads. Always replace shear bolts with identical property class. Replace fasteners with the same or higher property class. If higher property class fasteners are used, tighten these to the strength of the original. Make sure fastener threads are clean and that you properly start thread engagement. When possible, lubricate plain or zinc plated fasteners other than lock nuts, wheel bolts, or wheel nuts, unless different instructions are given for the specific application.

¹ "Lubricated" means coated with a lubricant such as engine oil, fasteners with phosphate and oil coatings, or M20 and larger fasteners with JDM F13C, F13F or F13J zinc flake coating.

² "Dry" means plain or zinc plated without any lubrication, or M6 to M18 fasteners with JDM F13B, F13E or F13H zinc flake coating.

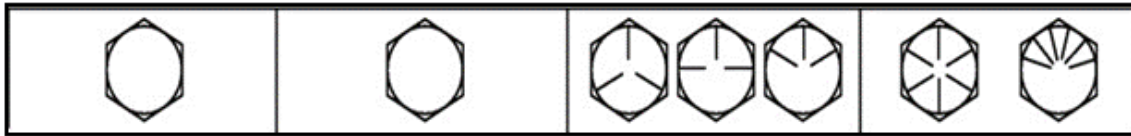

Figure 16: Common imperial bolt grade markings

Unified Inch Bolt and Screw Torque Values

Screw Size	SAE Grade 1				SAE Grade 2 ³				SAE Grade 5, 5.1 or 5.2				SAE Grade 8 or 8.2			
	Lubricated ⁴		Dry ⁵		Lubricated ⁴		Dry ⁵		Lubricated ⁴		Dry ⁵		Lubricated ⁴		Dry ⁵	
	N-m	lb.-in.	N-m	lb.-in.	N-m	lb.-in.	N-m	lb.-in.	N-m	lb.-in.	N-m	lb.-in.	N-m	lb.-in.	N-m	lb.-in.
1/4	3.7	33	4.7	42	6	53	7.5	66	9.5	84	12	106	13.5	120	17	150
													N-m	lb.-ft.	N-m	lb.-ft.
5/16	7.7	68	9.8	86	12	106	15.5	137	19.5	172	25	221	28	20.5	35	26
									N-m	lb.-ft.	N-m	lb.-ft.				
3/8	13.5	120	17.5	155	22	194	27	240	35	26	44	32.5	49	36	63	46
			N-m	lb.-ft.	N-m	lb.-ft.	N-m	lb.-ft.								
7/16	22	194	28	20.5	35	26	44	32.5	56	41	70	52	80	59	100	74
	N-m	lb.-ft.														
1/2	34	25	42	31	53	39	67	49	85	63	110	80	120	88	155	115
9/16	48	35.5	60	45	76	56	95	70	125	92	155	115	175	130	220	165
5/8	67	49	85	63	105	77	135	100	170	125	215	160	240	175	305	225
3/4	120	88	150	110	190	140	240	175	300	220	380	280	425	315	540	400
7/8	190	140	240	175	190	140	240	175	490	360	615	455	690	510	870	640
1	285	210	360	265	285	210	360	265	730	540	920	680	1030	760	1300	960
1-1/8	400	300	510	375	400	300	510	375	910	670	1150	850	1450	1075	1850	1350
1-1/4	570	420	725	535	570	420	725	535	1280	945	1630	1200	2050	1500	2600	1920
1-3/8	750	550	950	700	750	550	950	700	1700	1250	2140	1580	2700	2000	3400	2500
1-1/2	990	730	1250	930	990	730	1250	930	2250	1650	2850	2100	3600	2650	4550	3350
Torque values listed are for general use only, based on the strength of the bolt or screw. DO NOT use these values if a different torque value or tightening procedure is given for a specific application. For plastic insert or crimped steel type lock nuts, for stainless steel fasteners, or for nuts on U-bolts, see the tightening instructions for the specific application. Shear bolts are designed to fail under predetermined loads. Always replace shear bolts with identical grade.									Replace fasteners with the same or higher grade. If higher grade fasteners are used, tighten these to the strength of the original. Make sure fastener threads are clean and that you properly start thread engagement. When possible, lubricate plain or zinc plated fasteners other than lock nuts, wheel bolts, or wheel nuts, unless different instructions are given for the specific application.							

³ Grade 2 applies for hex cap screws (not hex bolts) up to 6 in. (152 mm) long. Grade 1 applies for hex cap screws over 6 in. (152 mm) long, and for all other types of bolts and screws of any length.

⁴ "Lubricated" means coated with a lubricant such as engine oil, fasteners with phosphate and oil coatings, or 7/8 in. and larger fasteners with JDM F13C, F13F or F13J zinc flake coating.

⁵ "Dry" means plain or zinc plated without any lubrication, or 1/4 to 3/4 in. fasteners with JDM F13B, F13E or F13H zinc flake coating.

Face Seal Fittings Assembly & Installation - All Pressure Applications

Face Seal O-Ring to Stud End Installation

1. Inspect the fitting surfaces. They must be free of dirt and defects.
2. Inspect the O-ring. It must be free of damage and defects.
3. Lubricate the O-rings and install them into the groove using petroleum jelly to hold them in place.
4. Push the O-ring into the groove with petroleum jelly so that the O-ring is not displaced during assembly.
5. Index any angle fittings and tighten by hand, pressing the joint together to ensure that the O-ring remains in place.
6. Tighten the fitting or nut to the torque value shown on the chart per dash size stamped on the fitting. DO NOT allow hoses to twist when tightening fittings.

Face Seal Adjustable Stud End O-Ring Installation

1. Back off the lock nut (jam nut) and washer to fully expose turned down section of the fitting.
2. Install a thimble over the fitting threads to protect the O-ring from nicks.
3. Slide the O-ring over the thimble into the turned down section of the fitting.
4. Remove thimble.

Face Seal Straight Stud End O-Ring Installation

1. Install a thimble over the fitting threads to protect the O-ring from nicks.
2. Slide the O-ring over the thimble into the turned down section of the fitting.
3. Remove thimble.

Fitting Installation

1. Install the fitting by hand until it is snug.
2. Position adjustable fittings by unscrewing the fitting no more than one turn.
3. Apply with an assembly torque per table.

Assembly Torque

1. Use one wrench to hold the connector body and one wrench to tighten the nut.
2. For a hydraulic hose, it may be necessary to use three wrenches to prevent twist: one on the connector body, one on the nut, and one on the body of the hose fitting.

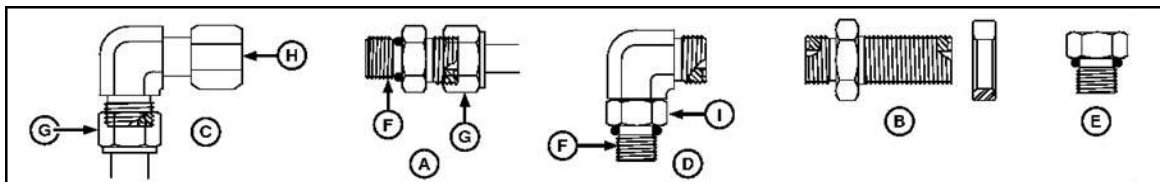

Figure 17: Common hydraulic fitting shapes and components

- | | |
|---|---------------|
| A. Stud Straight and Tube Nut | G. Tube Nut |
| B. Bulkhead Union and Bulkhead Lock Nut | H. Swivel Nut |
| C. 90° Swivel Elbow and Tube Nut | I. Lock Nut |
| D. 90° Adjustable Stud Elbow | |
| E. Port Plug | |
| F. Stud End | |



TIGHTENING HARDWARE

SAE Face Seal and O-Ring Stud End Fitting Torque Chart

SAE Face Seal and O-Ring Stud End Fitting Torque Chart - Standard Pressure-Below 27.6 MPA (4,000 PSI)																	
Nominal Tube OD Hose ID				O-Ring Face Seal/ Tube Swivel Nut				Bulkhead Jam Nut Torque			O-Ring Straight, Adjustable, and External Port Plug Stud Ends ⁶						
Metric Tube OD	Inch Tube OD			Thread Size	Swivel Nut Hex Size	Tube Nut Swivel Nut Torque		Jam Nut Hex Size	Jam Nut Torque		Thread Size	Straight Hex Size ⁷	Adj Lock Nut Hex Size	Steel or Gray Iron Torque		Aluminum or Brass Torque ⁸	
	mm	Dash Size	in.			mm	in.		N-m	lb.- ft				N-m	lb.- ft	in.	in.
5	-3	0.188	4.78	—	—	—	—	—	—	—	3/8-24	5/8	9/16	12	9	8	6
6	-4	0.250	6.35	9/16-18	11/16	16	12	13/16	32	24	7/16-20	5/8	5/8	16	12	11	8
8	-5	0.312	7.92	—	—	—	—	—	—	—	1/2-20	3/4	11/16	24	18	16	12
10	-6	0.375	9.53	11/16-16	13/16	24	18	1	42	31	9/16-18	3/4	3/4	37	27	25	18
12	-8	0.500	12.70	13/16-16	15/16	50	37	1-1/8	93	69	3/4-16	7/8	15/16	50	37	33	25
16	-10	0.625	15.88	1-14	1-1/8	69	51	1-5/16	118	87	7/8-14	1-1/16	1-1/16	69	51	46	34
20	-12	0.750	19.05	13/16-12	1-3/8	102	75	1-1/2	175	129	11/16-12	1-1/4	1-3/8	102	75	68	50
22	-14	0.875	22.23	13/16-12	—	102	75	—	175	129	13/16-12	1-3/8	1-1/2	122	90	81	60
25	-16	1.000	25.40	17/16-12	1-5/8	142	105	1-3/4	247	182	15/16-12	1-1/2	1-5/8	142	105	95	70
32	-20	1.25	31.75	1-11/16-12	1-7/8	190	140	2	328	242	1-5/8-12	1-3/4	1-7/8	190	140	127	93
38	-24	1.50	38.10	2-12	2-1/4	217	160	2-3/8	374	276	1-7/8-12	2-1/8	2-1/8	217	160	145	107
50.8	-32	2.000	50.80	—	—	—	—	—	—	—	2-1/2-12	2-3/4	2-3/4	311	229	207	153

⁶ Tolerance is +15%/-20% of mean tightening torque unless otherwise specified.

⁷ The straight hex wrench sizes listed apply to connectors only and may not be the same as the corresponding plug of the same thread size.

⁸ These torques were established using steel plated connectors in aluminum and brass.



Fast Ag Solutions
4130 Commerce Boulevard
Windom, MN 56101

1-800-772-9279 Toll Free

1-507-427-3861 Voice

1-507-427-3030 Fax

<https://fastagsolutions.com/>