



**AP COULTER
OPERATION, MAINTENANCE &
PARTS MANUAL**







Limited Warranty

Fast Ag Solutions warrants to the buyer that the new machinery is free from defects in material and workmanship.

This warranty is only effective as to any new machinery which has not been altered, changed, repaired or treated since its delivery to the buyer, other than by Fast Ag Solutions or its authorized dealers or employees, and does not apply to accessories, attachments, tools or parts, sold or operated with the new machinery, if they have not been manufactured by Fast Ag Solutions.

Fast Ag Solutions shall only be liable for defects in the materials or workmanship attributable to faulty material or bad workmanship that can be proved by the buyer, and specifically excludes liability for repairs arising as a result of normal wear and tear of the new machinery or in any other manner whatsoever, and without limiting the generality of the foregoing, excludes application or installation of parts not completed in accordance with this operator's manual, specifications, or printed instructions.

Written notice shall be given by registered mail, to the Manufacturer within seven (7) days after the defect shall have become apparent or the repairs shall have become necessary, addressed as follows:

Fast Ag Solutions
4130 Commerce Boulevard
Windom, MN 56101

This warranty shall expire one (1) year after the date of delivery of the new machinery.

If these conditions are fulfilled, Fast Ag Solutions shall at its own cost and at its own option either repair or replace any defective parts provided that the buyer shall be responsible for all expenses incurred as a result of repairs, labor, parts, transportation or any other work, unless Fast Ag Solutions has authorized such expenses in advance.

The warranty shall not extend to any repairs, changes, alterations, or replacements made to the new equipment other than by Fast AG Solutions or its authorized dealers or employees.

This warranty extends only to the original owner of the new equipment.

Rubber parts (including tires, hoses, grommets) are not warranted.

This warranty is limited to the terms stated herein and is in lieu of any other warranties whether express or implied, and without limiting the generality of the foregoing, excluded all warranties, express or implied or conditions whether statutory or otherwise as to quality and fitness for any purpose of the new equipment. The Manufacturer disclaims all liability for incidental or consequential damages.

Fast Ag Solutions products are subject to design changes, and Fast Ag Solutions shall not be required to retrofit or exchange items on previously sold units except at its own option.

Warranty void if not registered.



Table of Contents

Section	Page
INTRODUCTION.....	5
GENERAL SAFETY.....	6
MAIN COMPONENTS.....	10
COULTER INSTALL.....	12
COULTER ADJUSTMENT.....	14
INJECTOR NOZZLE ASSEMBLY.....	16
COULTER KNIFE ASSEMBLY.....	17
DEFENDER®.....	20
MAINTENANCE.....	21
ILLUSTRATED PARTS LIST.....	22

INTRODUCTION



Read this manual carefully before operating your FAST equipment. The information presented will prepare you to safely operate and service your machine. Require all operators to read this manual carefully and be acquainted with all the operating and adjustment procedures before attempting to operate. Failure to follow the information in this manual and on decals may result in personal injury or equipment damage.

This manual should be considered a permanent part of this equipment and should remain with the equipment when you sell it. Replacement manuals can be obtained from your FAST dealer.

This equipment has been engineered and manufactured to provide dependable and satisfactory use. Like all mechanical products, it will require cleaning and upkeep. Inspect your equipment before putting it into service. Your authorized FAST dealer has trained mechanics, genuine FAST service parts, and the necessary tools and equipment when service is needed. Use only genuine FAST parts for service or repairs. Substitute parts will void the warranty and may not meet standards for safe and satisfactory operation.

Warranty is provided as part of FAST's support program for customers who operate and maintain their equipment as described in this manual. The warranty is explained on the warranty certificate you should have received from your dealer. This warranty provides you with the assurance that FAST will back its products where defects appear within the warranty period. Should the equipment be abused or modified to change its performance beyond the original factory specifications, the warranty will become void.

These instructions have been compiled from field experience and engineering data. Some information may be general in nature, due to unknown and varying operating conditions. However, through experience and these instructions, you should be able to develop procedures suitable to your particular situation.

The illustrations and data used in this manual were current at the time of printing. However, due to possible in-line production changes, your machine may vary slightly in detail. We reserve the right to redesign and change the machines as may be necessary without notification.

SAFETY

The most important safety device on this equipment is a safe operator. It is the operator's responsibility to read and understand and follow all safety and operating instructions in this manual.

As the operator, you are responsible for the safe operation and maintenance of this equipment. You must ensure that you and anyone else who is going to operate, maintain or work around the machine is familiar with the operating and maintenance procedures and related safety information contained in this manual.

You are the key to safety. Good safety practices protect you and people around you. Be certain that everyone operating this equipment is familiar with the recommended operating and maintenance procedures and follows all safety precautions. Do not risk injury or death by ignoring good safety practices.

Safety Alert Symbols and Signal Words

Throughout this manual, the terms Caution, Warning, and Danger are used along with the safety alert symbol indicate the degree personal safety hazard. The term Important is used to indicate that failure to observe can cause damage to the equipment.



SAFETY ALERT SYMBOL

A SAFETY ALERT SYMBOL means there is a hazard. Become Alert! Your Safety is Involved!



DANGER

The word DANGER indicates an imminently hazardous situation that, if not avoided, will result in death or serious injury.



WARNING

The word WARNING indicates a potentially hazardous situation that, if not avoided, could result in death or serious injury.



CAUTION

The word CAUTION indicates a potentially hazardous situation that if not avoided may result in minor or moderate injury.

IMPORTANT

The word IMPORTANT indicates that failure to observe can cause damage to equipment.

NOTE

The word NOTE indicates helpful information.

GENERAL SAFETY

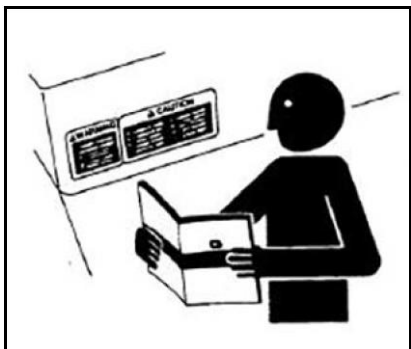

Carefully read and follow all safety messages in this manual and safety signs (decals) on equipment.

A safety sign may contain more than one hazard message and more than one avoidance panel.

Keep the equipment in proper working condition. Unauthorized modifications to the equipment may impair the function and/or safety and affect machine life.

If you do not understand any part of this manual and need assistance, contact your FAST dealer.

Prepare for Emergencies

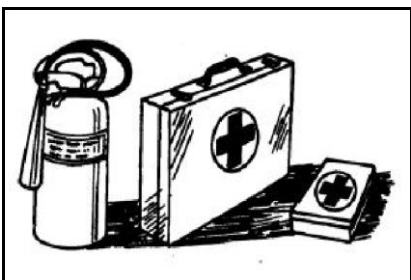

Keep a fire extinguisher and first aid kit handy. Know how to use them.

Keep emergency numbers for doctors, ambulance service, hospital, and fire department near your telephone.

Keep the Poison Control emergency telephone number for your area on equipment before using chemicals.

Have the chemical container and SDS available when seeking medical attention.

Personal Protection Equipment (PPE)



Wear close fitting clothing and safety equipment appropriate for the job.

Wear the appropriate protective clothing and devices as described on the chemical SDS sheet.

Handle Chemicals Safely

Direct exposure to hazardous chemicals can cause serious injury.

A Safety Data Sheet (SDS) (formerly Material Safety Data Sheet (MSDS)) provides specific details on chemical products: physical and health hazards, safety procedures, and emergency response techniques.

Read the chemical manufacturers warning, instructions and procedures before starting and follow them exactly.

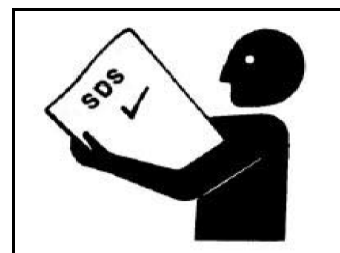

Potentially hazardous chemicals are used with FAST equipment include such items as lubricants, coolants, paints, and adhesives.

Check the SDS before you start any job using a hazardous chemical. That way you will know exactly what the risks are and how to do the job safely. Then follow procedures and recommended equipment.

Keep Riders Off Machine

Do not allow riders on the equipment or the tractor during operation or transport.

Riders are subject to injury from being struck by foreign objects, exposure to chemicals, and being thrown off the machine.



Riders obstruct the operator's view resulting in the machine being operated in an unsafe way.

Riders are subject to exposure to chemicals as they are being applied which could create a health hazard.

Maintenance Safety

Understand service procedures before starting work. Keep service area clean and dry. Never lubricate, service or adjust machine while it is moving. Keep hands, feet and clothing from power-driven parts.

Lower equipment to the ground.

Relieve pressure before serving or disconnecting from the tractor.

Stop the engine. Remove the key. Allow the machine to cool.

Securely support all machine elements that must be raised for service work. Use tools, jacks, and hoists of sufficient capacity for the job.

Clear area of bystanders when making adjustments, servicing or repairing the equipment.

Use adequate lighting for the job.

Keep all parts in good condition and properly installed. Fix damaged components immediately. Replace worn and broken parts.

Remove any build-up of grease, oil, or debris.

Remove paint and any residue from solvents before welding or heating.

Waste Disposal Safety

Improper disposal of waste can threaten the environment and ecology. Potentially harmful waste used with FAST equipment includes oil, coolant, brake fluid, filters, and batteries.

Use leak-proof containers when draining fluids. Do not use food or beverage containers that may mislead someone into drinking from them.

Do not pour waste onto the ground, down a drain, or into any water source.

Follow instructions on chemical containers or SDS sheets for disposal of chemicals, containers, and water used for cleaning the equipment.

Safety Signs (Decals)

Keep safety signs in good condition.

Replace missing or damaged safety signs.

Be sure new equipment components and repair parts include the current safety signs.

Replacement signs are available from your FAST dealer.

Storage Safety

Store equipment away from human activity.

Do not allow children to play on or around the stored machine.

Lower the machine and securely block.

Transportation Safety

Obey all applicable laws and regulations for transporting equipment.

Operation Safety

Read and understand this Operator's Manual and all safety signs before using.

Before each use inspect the entire machine. Check tightness of nuts and bolt and fittings.

Keep hands, feet, hair, and clothing away from all moving parts.

Do not allow riders on the equipment or tractor.

Make sure everyone is clear of the machine before filling equipment tank, starting tractor engine or beginning operation.

Read chemical or fertilizer manufacturers warnings, instructions, and procedures before starting and follow them exactly.

Do not breathe, touch or ingest chemicals or fertilizers. Always wear protective clothing and follow safe handling procedures.

MAIN COMPONENTS

- 1. Octagon Shaft
- 2. Liquid Hose
- 3. Tension Spring
- 4. Coulter Blade
- 5. Coulter Mount
- 6. Coulter Rotation Plate
- 7. Square Shaft
- 8. Nozzle
- 9. Rock Guard
- 10. Hub

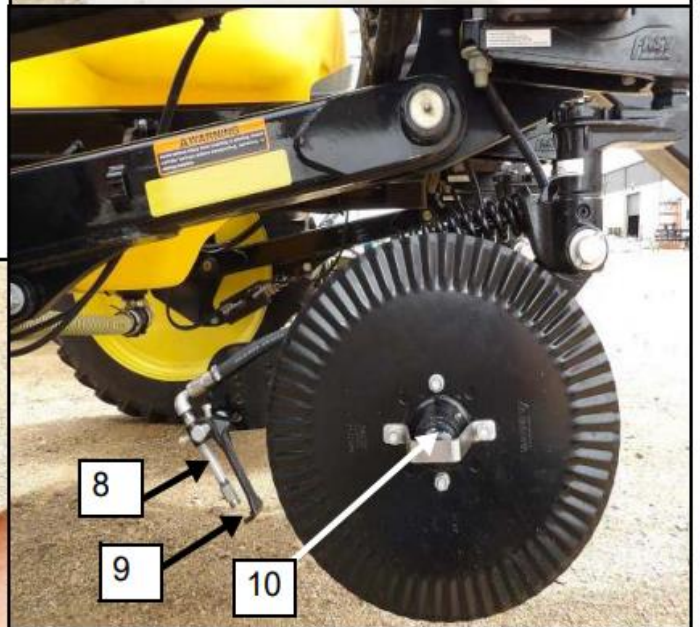
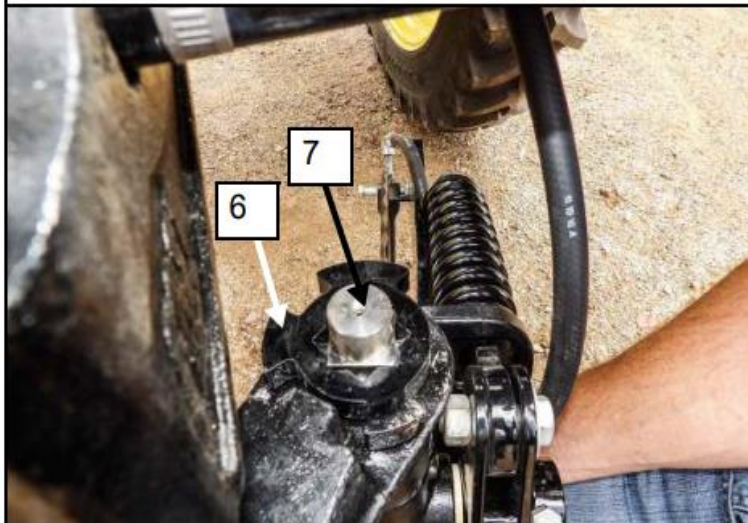
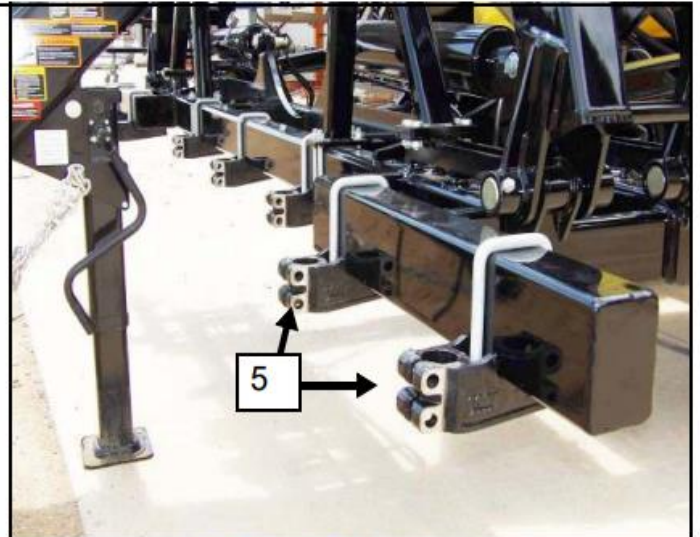
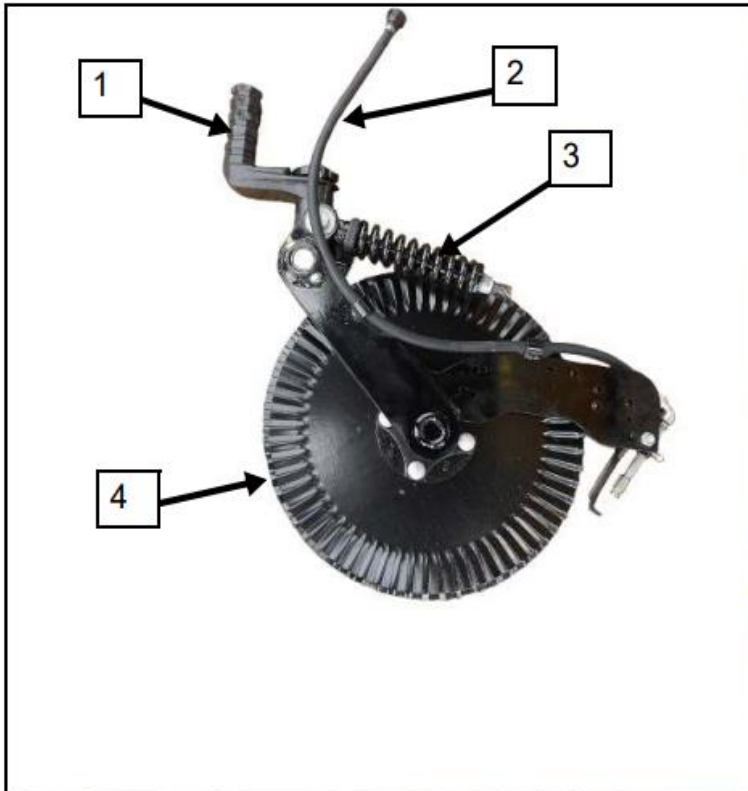

Optional

A. Knife Assembly

B. Defender®

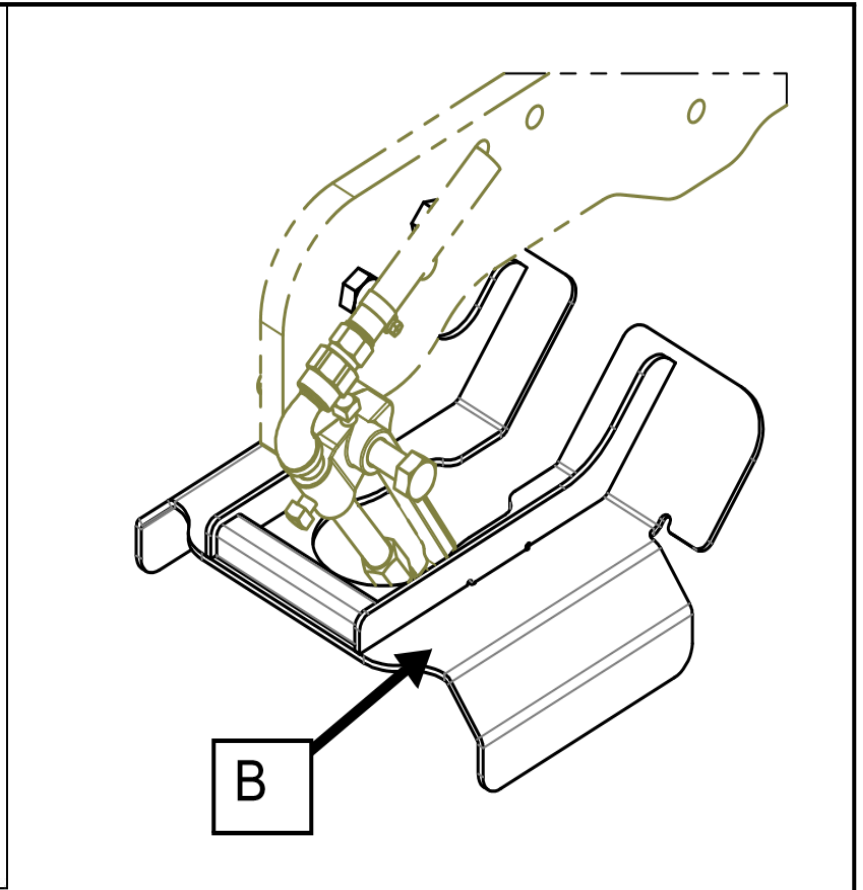
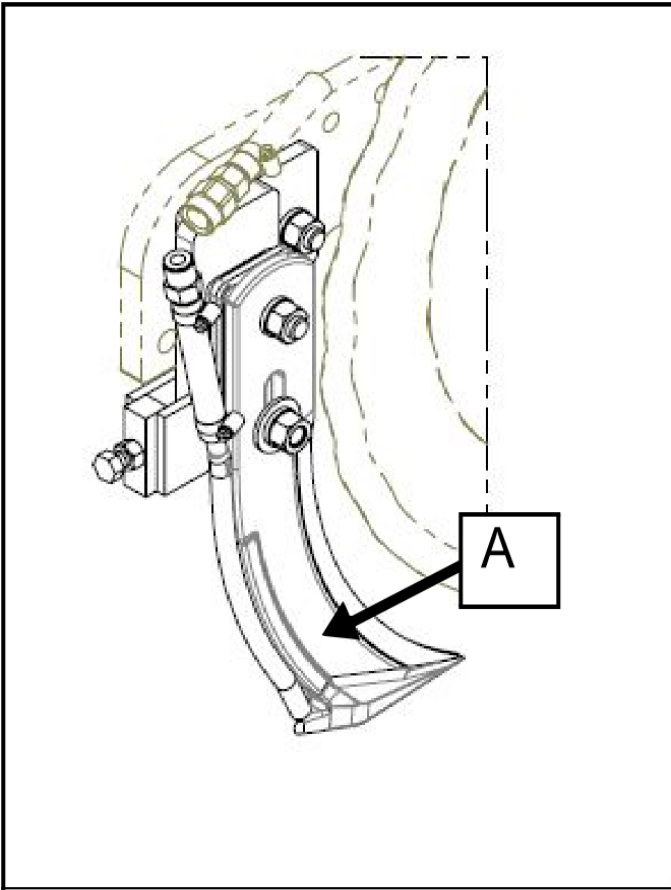

COULTER INSTALL

COULTER MOUNTS

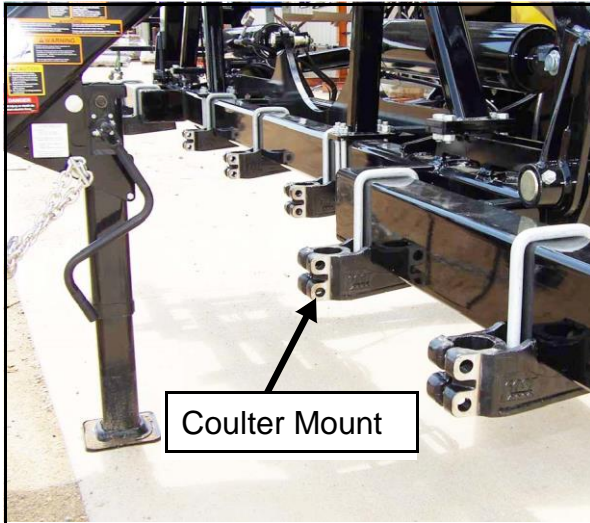

1. Measure the position of each Coulters Mount. Adjust position as needed.
2. Torque to 270 N-m (200 ft-lbs.)



Nut and washer arrangement for Coulters Mount.

INSTALL THE COULTER

The octagon shaft set forward is the standard position, but the shaft can be rotated as needed to provide mounting clearance.

The coulters offset can be positioned in 45-degree increments by the Octagon Shaft in the Coulters Mount.

45 degrees = 89 mm (3.5") offset

90 degrees = 127 mm (5") offset

The range of swing motion can be set by positioning the Coulters Rotation Plate on the square shaft. The Coulters Rotation Plate can be flipped upside down for more range options. See "COULTERS ADJUSTMENT".



Coulters in line with mount

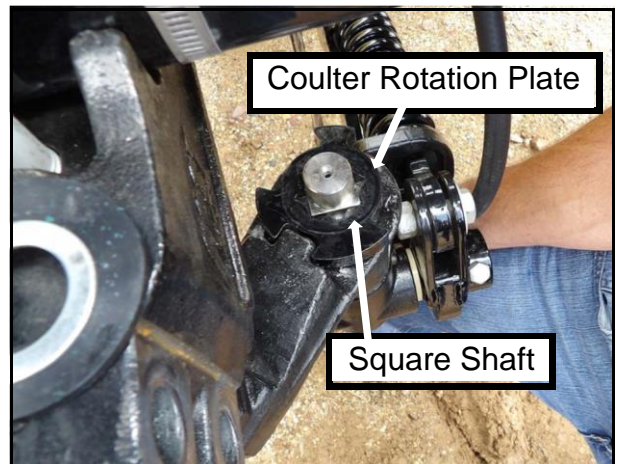

Coulters rotated 45° with Coulters Rotation Plate positioned for no rotation.



3. Lift the Coulters and insert the octagon shaft into the mount.



5. Adjust the Coulters height to allow both cross bolts to be installed in line with the grooves in the octagon shaft.

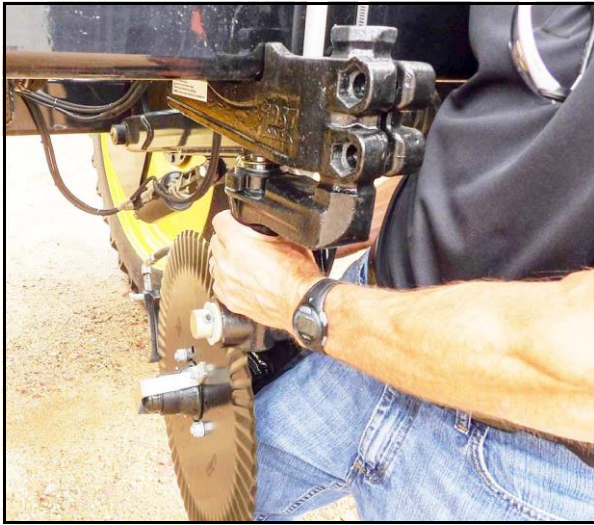

4. Raise the Coulters to the desired height.



6. Torque to 285 N-m (210 ft-lbs.). Increase torque until the Octagon Shaft does not wiggle in the Coulters Mount.
7. Repeat to install all Coulters.

NOTE: Refer to the equipment manual for the for plumbing instructions.

COULTER ADJUSTMENT

ADJUST COULTER SIDE-TO-SIDE MOVEMENT



1. Adjust the side-to-side movement of the Coulters by removing the pin.



2. Remove the washers.



3. Turn the Coulters and adjust the position of the Coulters Rotation Plate.
 - The Coulters Rotation Plate can be flipped over for more range of motion options.
4. Set the Coulters Rotation Plate against the tab on the Octagon Shaft to adjust the range of side-to-side movement of the Coulters.



No side-to-side movement

ADJUST COULTER DOWN PRESSURE

The Coulters down pressure is obtained by the pressure spring.

NOTE: Down pressure has been preset at the factory.



Limited side to side movement



Maximum side to side movement



5. Reinstall the washer and pin.

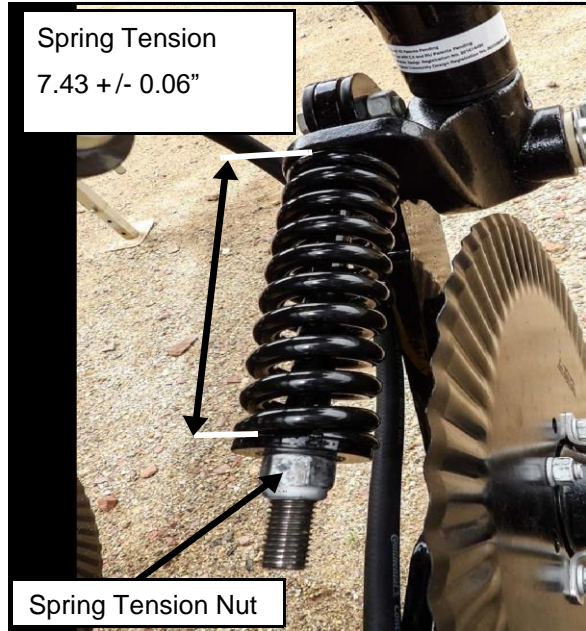

Adjust down pressure with the tension spring nut.

- Tighten to increase pressure.
- Loosen to decrease pressure.
- Tension until spring measures $7.43 \pm 0.06"$ (18.87 ± 0.15 cm).

NOTE: For every 1/4" of extra spring compression coulters vertical travel is reduced by 1".

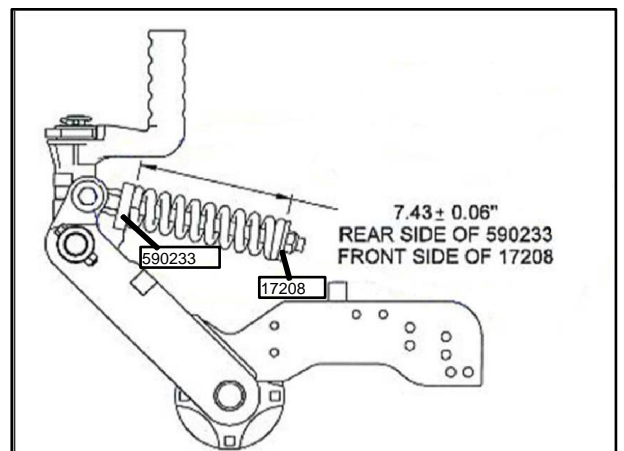

INJECTOR NOZZLE ASSEMBLY

Organize all injector parts on table. Use liquid thread sealer on all threads.

IMPORTANT: There are two orifice tip sizes depending upon the machine configuration and application rate. The bag containing **ONLY TWO ORIFICE TIPS ALWAYS GO TO THE OUTSIDE END COULTERS.** The remaining tips go to all other coulters.

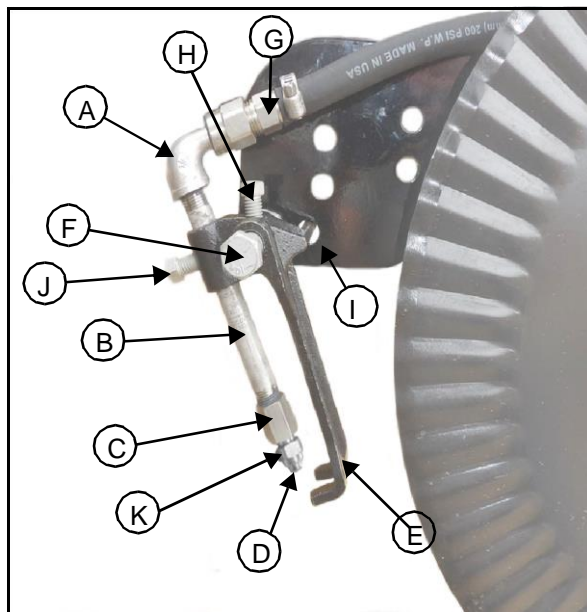

- A. 90° Elbow
- B. 5 in. Nipple
- C. Female Inlet
- D. Injector Orifice Tip, (Refer to IMPORTANT Above)
- E. Bracket
- F. Bolt 1/2 x 4 in, Jam Nut and Nylock Nut
- G. Check Value With Hose Barb
- H. Center Set Screw
- I Bottom Two Shank Holes
- K. Nut

6. Install injector assembly in bottom two shank holes (I).
7. Tighten Nylock nut and jam nut.

ADJUST INJECTOR NOZZLE

For best performance the Injector Nozzle should be adjusted so that it puts the stream of liquid directly into the slot the Coulter Blade made.

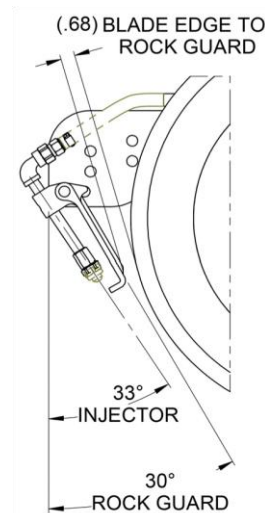

1. Visually site the injector Nozzle position related to the Coulter. To adjust the Nozzle angle:
 - Loosen setscrew (H) to adjust the Nozzle angle and center the stream about 50 mm (2 in.) or as close as practical behind the Coulter Blade.
2. To adjust the Nozzle height:
 - Loosen setscrew (J) to adjust the Nozzle height. The Nozzle tip should not extend past the Rock Guard.
3. Turn on the system and test stream position.
4. Adjust as needed.

COULTER KNIFE ASSEMBLY

Install the Coulter Knife Assembly

The optional Coulter Knife Assembly may be installed in place of the injector nozzle.

Non-Adjustable Knife Installation (2022 and newer)

This non-adjustable knife assembly fits in place of adjustable knife assembly on AP Coulters 2022 and older.

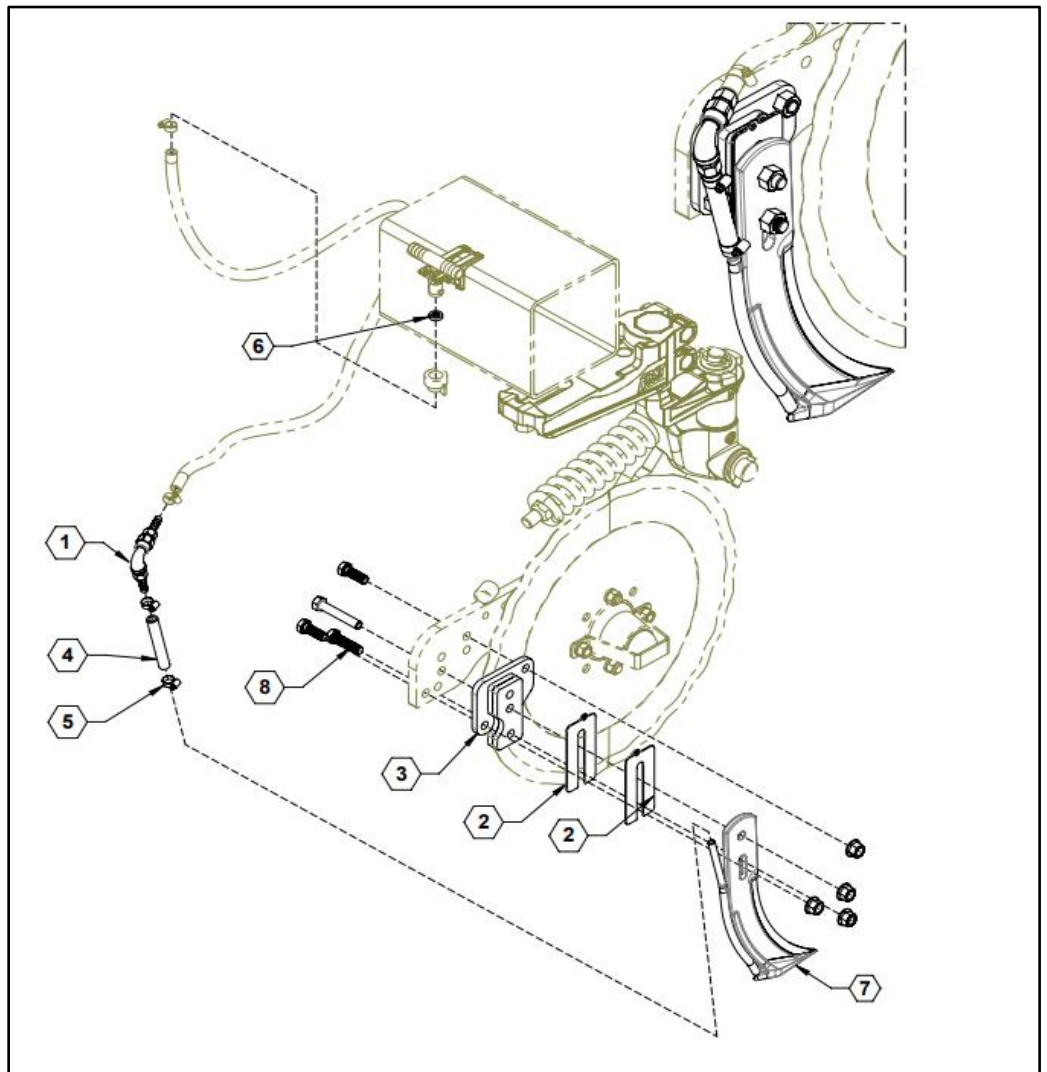
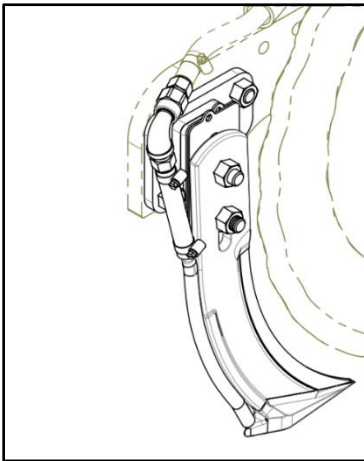

For part numbers and quantities, go to **AP Coulter Knife Option Assembly – Non-Adjustable** in the ILLUSTRATED PARTS LIST towards the end of this manual.

Adjustable Knife Assembly (2022 and older AP Coulters)

1. Insert the 3/8 x 2" bolt through the knife adjuster. Secure using a 3/8" jam nut on the outside and a 3/8" square nut on the inside. See "AP Coulters Knife Option Assembly" for part identification.
2. Install the knife mount (3) on to the coulters arm using 1/2" bolts. Secure from bolt with 1/2" lock washer and nut. Attach the knife adjuster (2) to the knife mount using a 1/2 x 2" bolt (11). Make sure the welded in washer is on the left side.

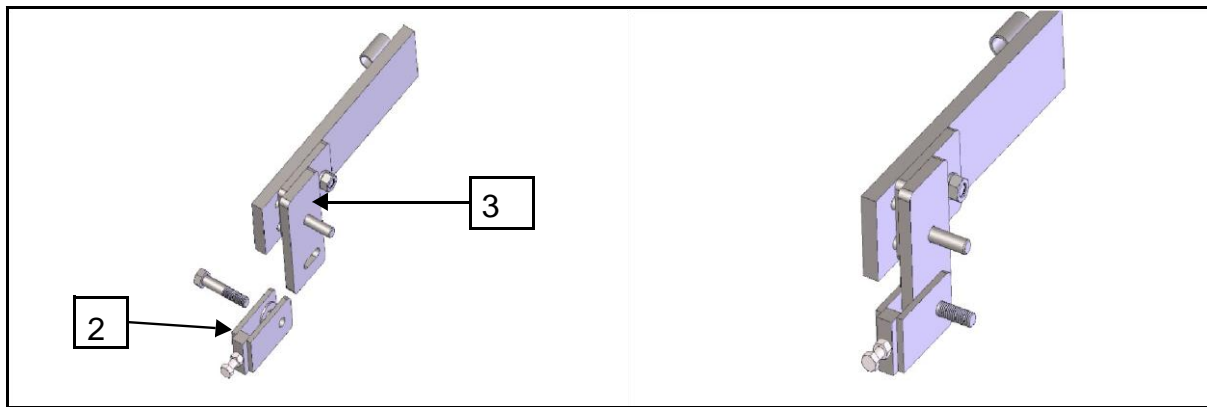
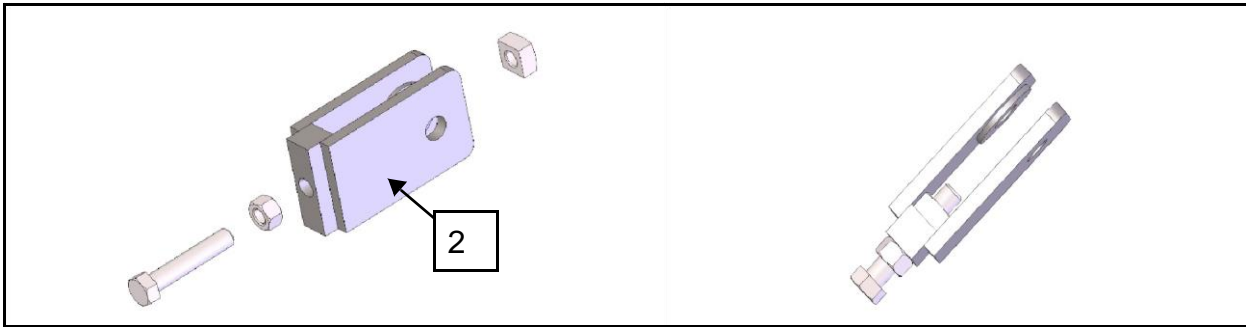

3. Add the 1/4" shim (1) to the top knife mount bolt. Add additional shims (4,5,6) as needed to align the knife behind the coulters blade.

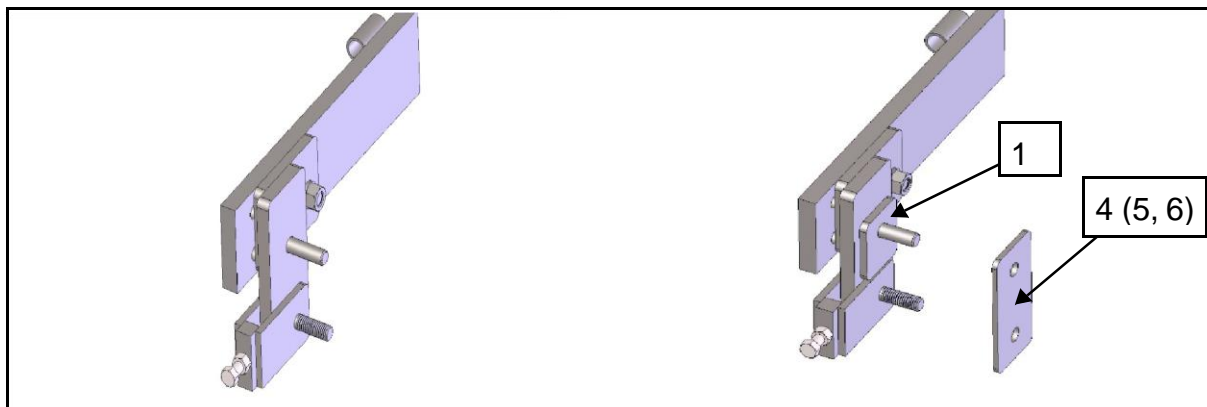

4. Install the knife (12) and loosely secure with ½" lock washers and nuts. Use a ½" flat washer on the lower knife slot.

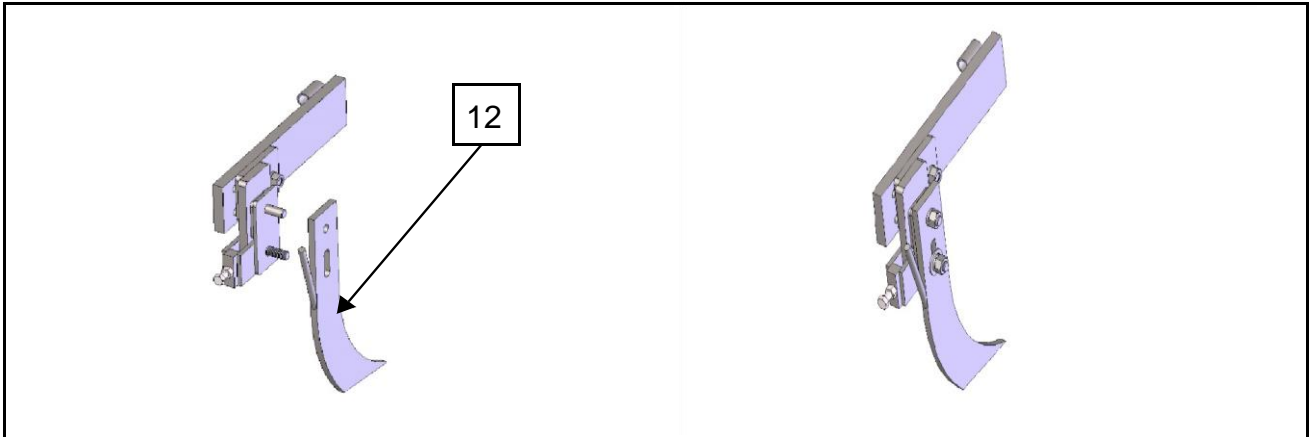

ADJUST THE KNIFE ASSEMBLY

1. Adjust the knife (12) so that there is a small gap between the blade and knife tip. Tighten the ½" nuts.
2. Adjust the 3/8" bolt on the knife adjuster so that it is tight against the knife mount. Tighten the 3/8" jam nut to secure.
3. After knife is properly adjusted with .26" (6.6mm) gap between knife tip and blade OD, spin blade to ensure the knife misses the blade, adjust as necessary.

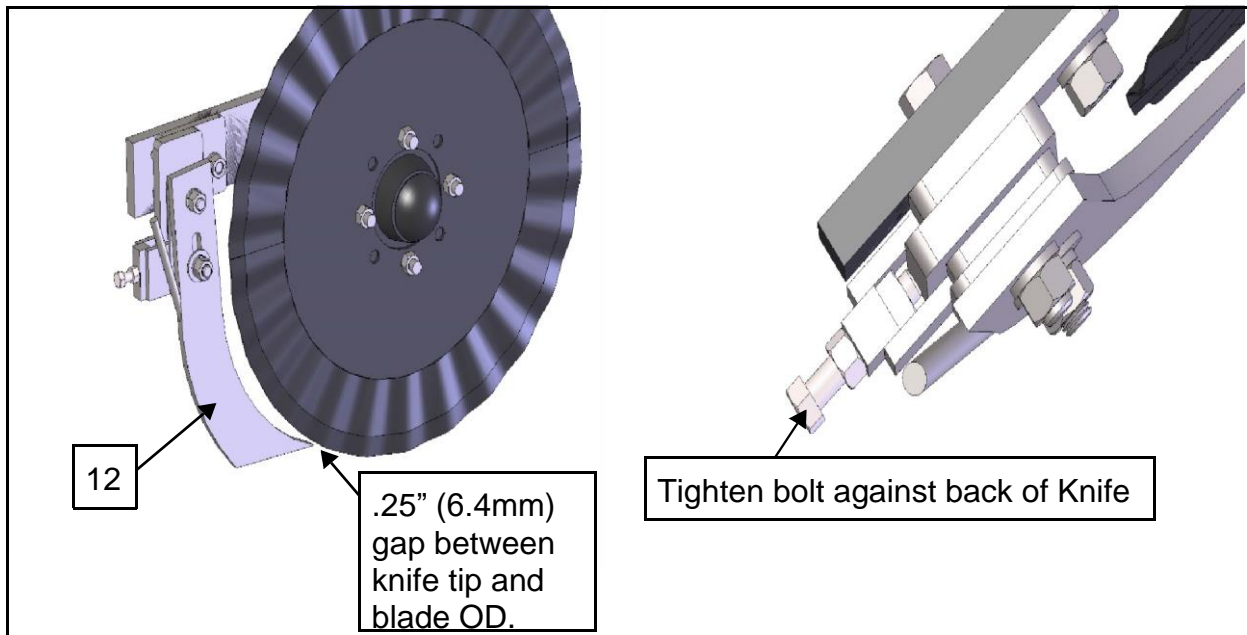

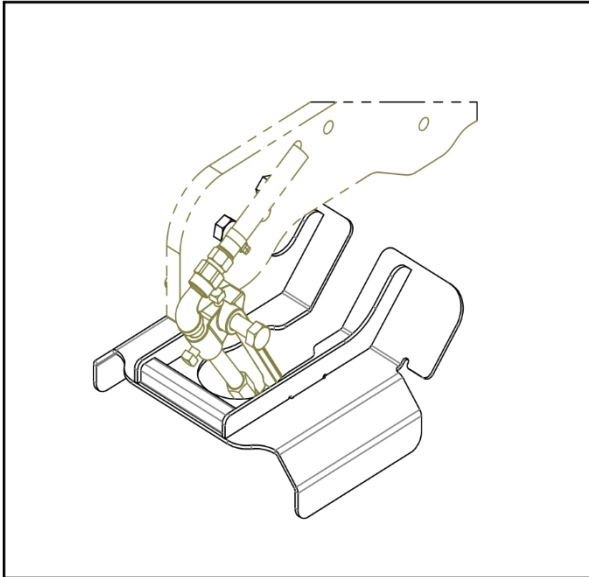
DEFENDER®

The optional Defender® is used to shield plants from airborne soil caused by Coulter rotation.

The Defender® is used with the injector nozzles.

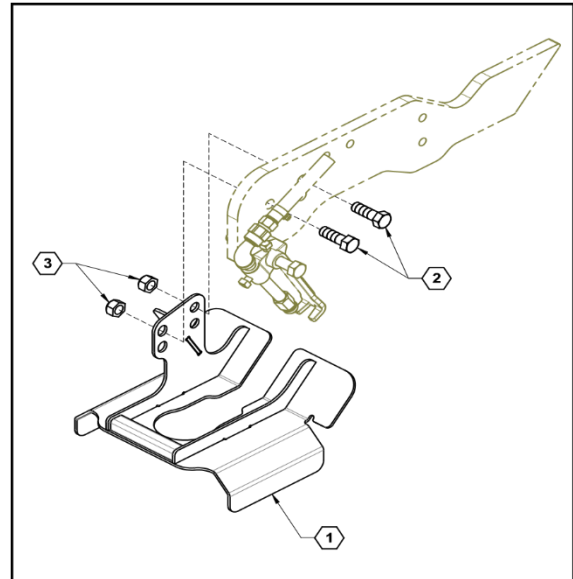
Install the DEFENDER®

See “DEFENDER® for Injection Assembly” for part identification.

1. Fit the Defender® (1) around the Injector Nozzle and Rock Guard.
2. Install the two bolts (2) with the bolt heads toward the Injector nozzle.
3. Install the Toplock nuts.
4. Adjust height by using the upper or lower mounting holes.

MAINTENANCE

1. Grease Coulters hubs through the provided zerks every 100 hours of use, before and after storage.



2. Inspect Coulters for damage before use and frequently when working in rocky conditions.
3. Replace bent, chipped or broken coulters blades.
 - Remove the 4 nuts and hub guard.
 - Remove the damaged coulters blades.
 - Install the new coulters blade.
 - Reinstall the hub guard and all 4 nuts.
 - Torque to 61 N-m (45 ft-lbs.)

ILLUSTRATED PARTS LIST

General Information

All rights, especially copying and distribution rights are reserved. No part of this publication may be reproduced in any form or by any means, electronic or mechanical, including photocopying, without express written permission from Fast Ag solutions.

The following illustration and parts list should be used to order parts for repairs. When ordering parts, match the item number in the illustration with the item number on the parts list, and then order using the part number following the item number in the parts list. When ordering, have your equipment serial number available, if applicable.

If you have any questions, please contact your Fast Ag Solutions Parts and Service Department.

The parts lists are broken down sub-assemblies and listed in 4 columns:

- **ITEM** - These numbers are found on the illustration associated with the parts list.
 - **NS** - This item is NOT SHOWN, included for reference.
- **QTY** - This is the quantity of parts needed in an assembly.
 - **AR** - The quantity of this item is AS REQUIRED for the location.
- **PART NO.** - These are the part numbers associated to the ITEM.
- **DESCRIPTION** - This is the description of the part.

Parts List – Table of Contents

Section	Page
ILLUSTRATED PARTS LIST	22
AP COULTER ASSEMBLY	24
<i>Parts List 34471: AP Coulter Assembly</i>	24
AP COULTER BASE ASSEMBLY.....	25
<i>Parts List 34470: AP Coulter Base Assembly</i>	26
N669 COMPLETE HUB WITH SQUARE HOLE WITH TRIPLE SEAL ASSEMBLY	27
<i>Parts List 26891 / 730095ASSY: N669 Complete Hub with Square Hole with Triple Seal</i>	27
AP COULTER UPPER CASTING MOUNTS (PRE-2025)	29
<i>Parts List: AP Coulter Upper Casting Mounts (pre-2025)</i>	30
AP COULTER UPPER CASTING MOUNTS	31
<i>Parts List 99FCUPCSA: AP Coulter Upper Casting Mounts</i>	31
AP COULTER INJECTION OPTION ASSEMBLY	32
<i>Parts List 90SAINJ: AP Coulter Injection Option Assembly</i>	33
AP COULTER BLADE HARDWARE KIT.....	34
<i>Parts List 590278: AP Coulter Blade Hardware Kit</i>	34
DEFENDER® FOR INJECTION ASSEMBLY	35
<i>Parts List 99CROPDEFENDER: DEFENDER® for Injection</i>	35
AP COULTER KNIFE HIGH FLOW KNIFE OPTION.....	36
<i>Parts List 37139: AP Coulter Knife High Flow Knife Option</i>	37
AP COULTER KNIFE OPTION ASSEMBLY – NON-ADJUSTABLE (2022 AND NEWER, BACKWARDS COMPATIBLE).....	38
<i>Parts List 34590: AP Coulter Knife Option Assembly – Non-Adjustable (2022 and newer, backwards compatible)</i>	39
AP COULTER KNIFE STOP HARDWARE KIT – ADJUSTABLE (2022 AND OLDER).....	40
<i>Parts List 99FCAPPKNIFE: AP Coulter Knife Stop Hardware Kit – Adjustable (2022 and older)</i>	41
DECAL ASSEMBLY.....	42
<i>Parts List 17292: Decal Assembly</i>	42

AP Coulter Assembly

- NOTE:
1. 7X7 TOOLBAR SHOWN FOR REFERENCE. 7X5 & 6X4 NOT SHOWN
 2. TORQUE U-BOLT TO 260 FT-LBS +/- 10 FT-LBS

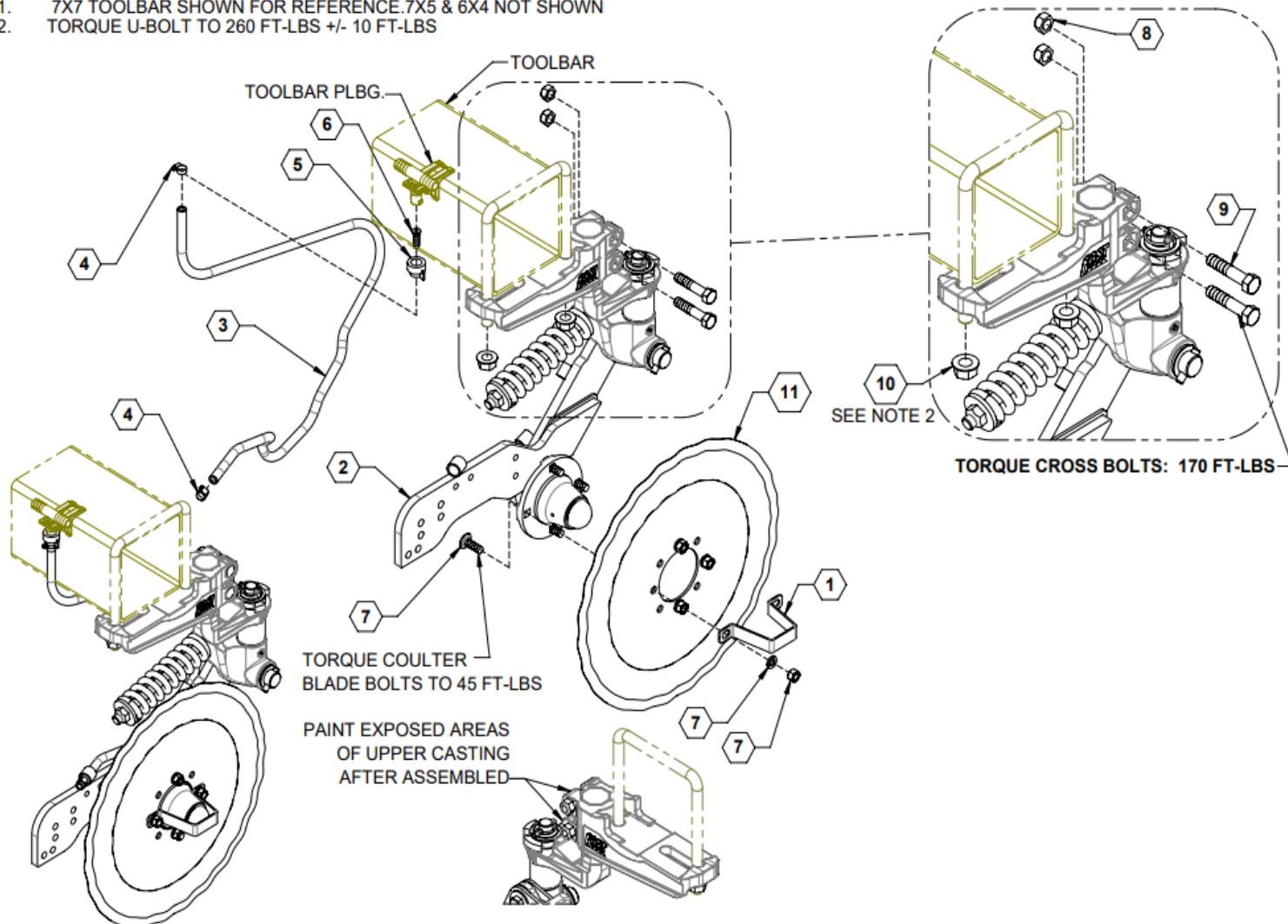

Parts List 34471: AP Coulter Assembly

ITEM	PART NO.	QTY.	DESCRIPTION
1	17214	1	HUB RETAINER BRACKET
2	34470	1	ASSY, UPDATED COULTER BASE
3	510020	1	HOSE, 3/8" EPDM X 4.5 FT
4	540032	2	CLAMP, HOSE SS 5/16" #5
5	590076	1	CAP, QT NYLON BLACK
6	590077	1	CONNECTOR, HOSE BARB
7	590278	1	HDWE KIT, COULTER BLADE KIT
8	596243M	2	NUT, TOPLOCK 5/8-11 G8 MAGNI
9	596779M	2	BOLT, HH 5/8 X 3 G8 MAGNI
10	596850M	2	NUT, HEX FLANGE TOPLOCK 3/4-10 GR8 MAGNI
11	750014	1	COULTER BLADE, 20' RIPPLED

AP Coultter Base Assembly

NOTE:

1. SET SPRING LENGTH AS SHOWN ON DRAWING
2. TIGHTEN BOLT UNTIL PLATES DEFLECT .06" +/- .03" MAKING SURE LOCK NUT FULLY ENGAGES ON BOLT
3. PAINT EXPOSED PIVOT SHAFT AFTER ASSEMBLED

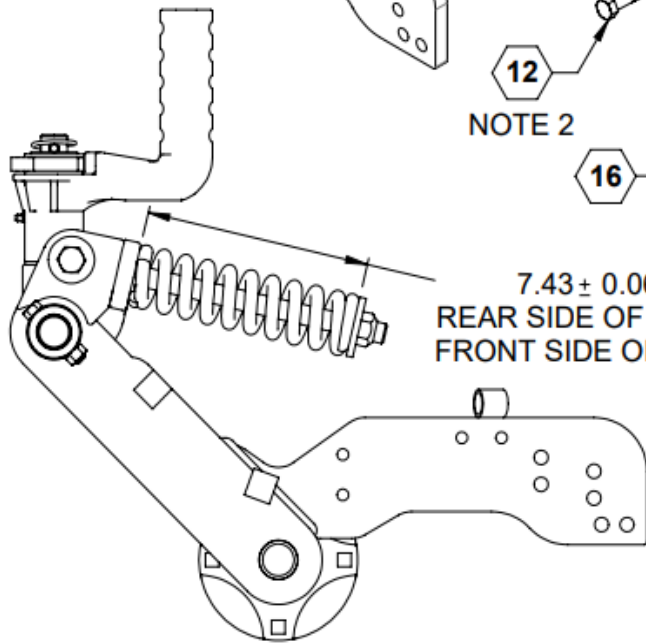
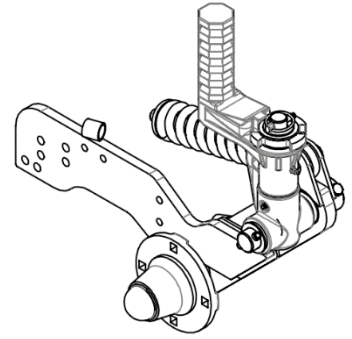
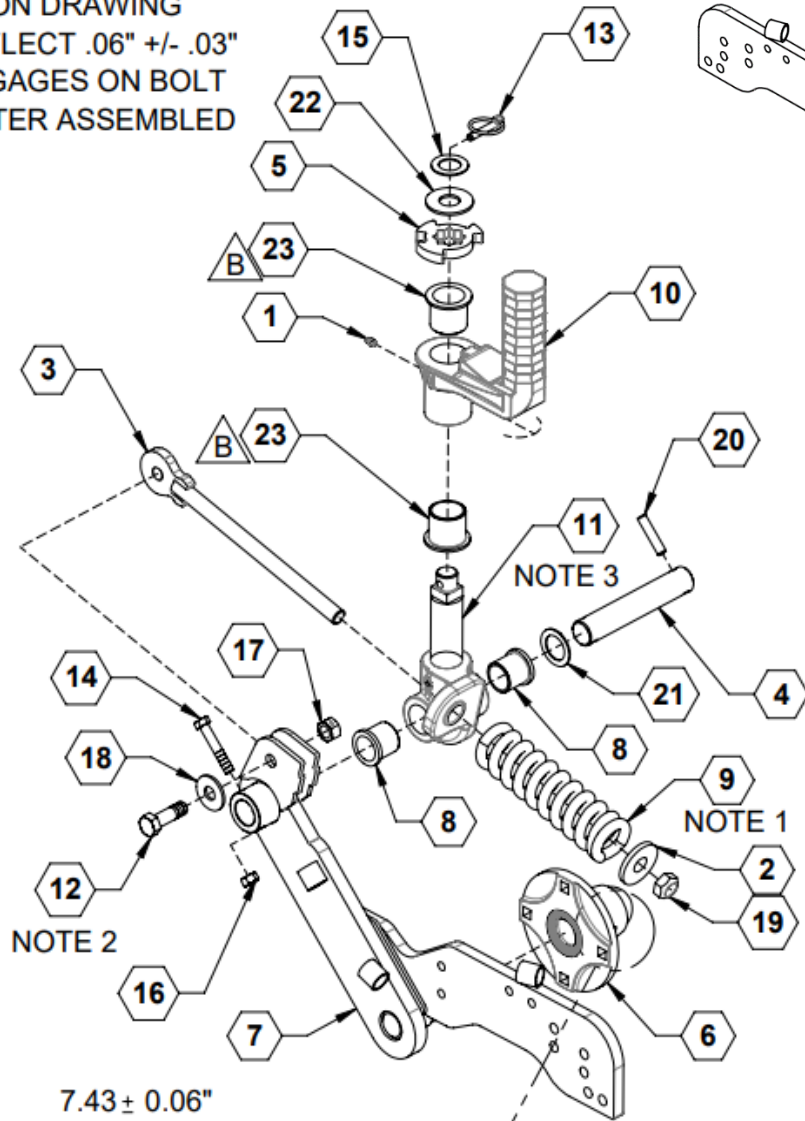
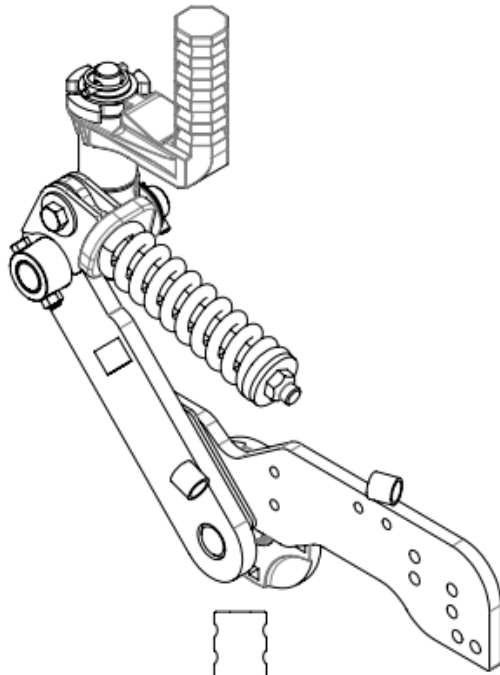

7.43 ± 0.06"
 REAR SIDE OF 590233
 FRONT SIDE OF 17208

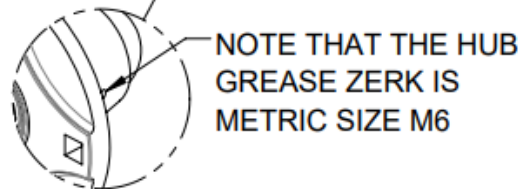

NOTE THAT THE HUB GREASE ZERK IS METRIC SIZE M6

Parts List 34470: AP Coulter Base Assembly

ITEM	PART NO.	QTY.	DESCRIPTION
1	759	1	ZERK, 1/4-28 STRAIGHT PIPE THREAD
2	17208	1	PLATE, SPRING END
3	17276	1	SPRING LEVER WELDMENT
4	17291	1	PIVOT SHAFT
5	21088	1	PLATE, COULTER ROTATION
6	26891	1	HUB, COULTER 4 BOLT
7	34472	1	COULTER ARM WELDMENT
8	530328	2	IGUS FLANGED BUSHING
9	590123	1	COULTER COMPRESSION SPRING
10	590232	1	MID CASTING
11	590233	1	LOWER CASTING
12	590290	1	BOLT, HH 5/8 X 2 SPECIAL, MAGNI
13	590819M	1	LYNCH PIN, 5/16 X 1-3/4 MAGNI
14	596143M	1	BOLT, HH 7/16 X 2-1/2 GR5 MAGNI
15	596179M	1	BUSHING, MACHINED 1' X 14GA MAGNI
16	596238M	1	NUT, CENTERLOCK 7/16-14 MAGNI
17	596240M	1	NUT, CENTERLOCK, 5/8-11 MAGNI
18	596261M	1	WASHER, FLAT 5/8 MAGNI
19	596626M	1	NUT, TOPLOCK 3/4-10 GR5 MAGNI
20	596740M	1	ROLL PIN, 7/16 X 2 MAGNI
21	596744M	1	BUSHING, MACHINE, 1-1/4 X 14 GA MAGNI
22	750086	1	UPPER DUST CAP WASHER
23	750094	2	COULTER PIVOT BUSHING

N669 Complete Hub with Square Hole with Triple Seal Assembly

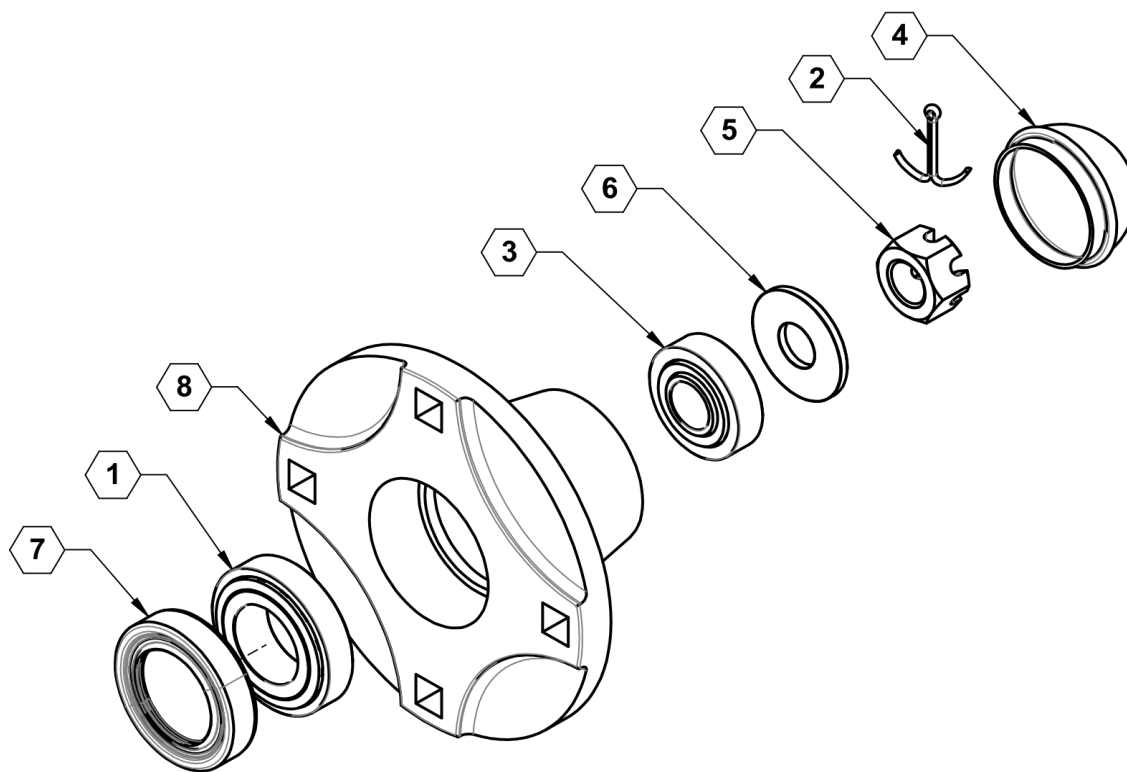

Parts List 26891 / 730095ASSY: N669 Complete Hub with Square Hole with Triple Seal

ITEM	FAST PART NO.	VENDOR PART NO.	QTY.	DESCRIPTION
1	730032		1	BEARING AND RACE, LG LM67048,
1		LM67048	1	BEARING
1		LM67010	1	RACE
2	730033		1	COTTER PIN, N669, 4-BOLT
3	730036		1	BEARING AND RACE, SM LM11949,
3		LM11949	1	BEARING
3		LM11910	1	RACE
4	730044		1	HUB CAP, (699/736) HUB
5	730088		1	CASTLE NUT 4-BOLT, 5/8-18
6	730096		1	WASHER, NSS9 4-BOLT
7	730102		1	SEAL, TRIPLE LIP ID
8	730104		1	HUB, W/ CUPS, 4 BOLT, N669



AP Coultter Upper Casting Mounts (pre-2025)

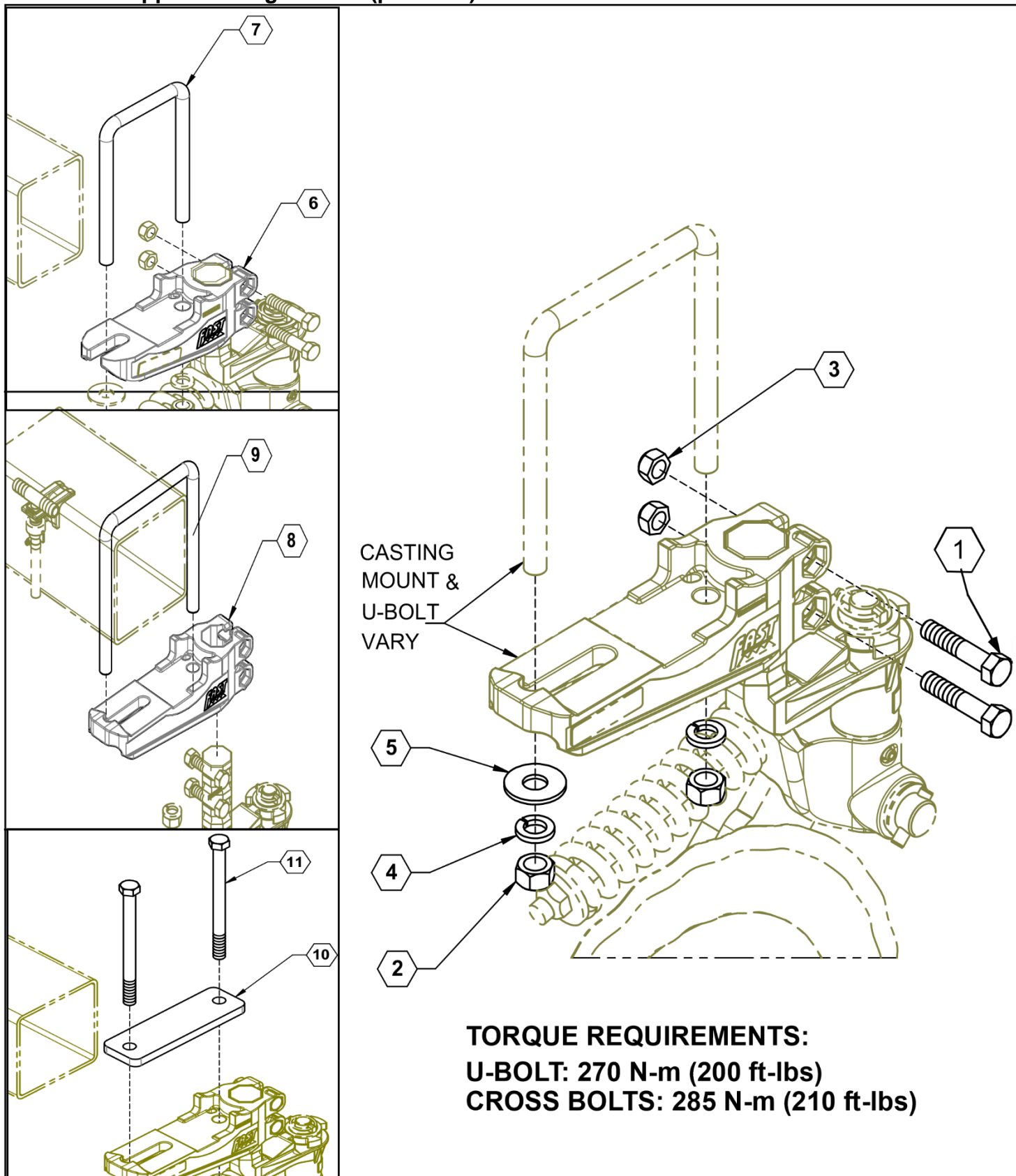

Parts List: AP Coultter Upper Casting Mounts (pre-2025)

ITEM	PART NO.	QTY.	DESCRIPTION
1	596779M	2	BOLT, G8 HEX 5/8 X 3 MAGNI
2	596217M	2	NUT, HEX 3/4-10 MAGNI
3	596243M	2	NUT, G8 TOPLOCK 5/8-11 MAGNI
4	596254M	2	LOCKWASHER 3/4 MAGNI
5	596259M	1	WASHER, FLAT 3/4 MAGNI
6	590310	1	MOUNT CASTING AP COULTER
7	596773M	1	U-BOLT, 7 X 5 MAGNI
	596772M	1	U-BOLT, 6 X 4 MAGNI
8	590231 <i>See AP Coultter Upper Casting Mounts for new version</i>	1	MOUNT CASTING, 7X7 TB
9	596774M	1	U-BOLT, 7 X 7 MAGNI
10	17284	1	PLATE, TOP
11	596197M	2	BOLT, 3/4-10 X 9-1/2 MAGNI

AP Coultter Upper Casting Mounts

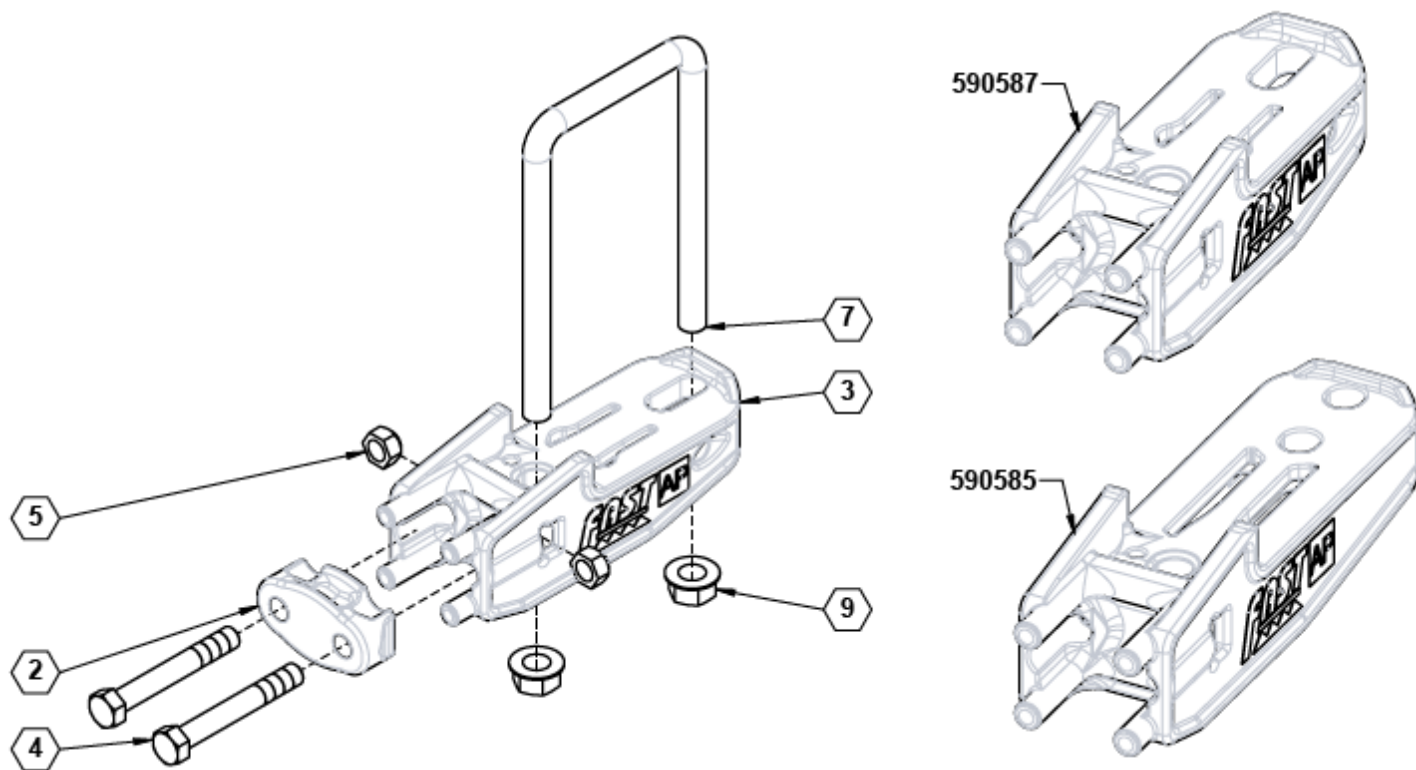

Parts List 99FCUPCSA: AP Coultter Upper Casting Mounts

ITEM	PART NO.	37646	37657	37657L	37677	DESCRIPTION
2	590586	1	1	1	1	UPPER MOUNT FRONT CLAMP
	590585	-	-	1	1	UPPER COULTER MOUNT, 5X7, 7X7
3	590587	1	1	-	-	UPPER COULTER MOUNT, 4X6, 5X7
4	596177M	2	2	2	2	BOLT, HH 5/8-11 X 4-1/2 GR5 MAGNI
5	596243M	2	2	2	2	NUT, TOPLOCK 5/8-11 G8 MAGNI
6	596772M	1	-	-	-	U-BOLT, 3/4 X 6 X 4 G5 MAGNI
7	596773M	-	1	1	-	U-BOLT, 3/4 X 7 X 5 G5 MAGNI
8	596774M	-	-	-	1	U-BOLT, 3/4 X 7 X 7 G5 MAGNI
9	596850M	2	2	2	2	NUT, HEX FLANGE TOPLOCK 3/4-10 GR8 MAGNI

AP Coulter Injection Option Assembly

No closing wheel

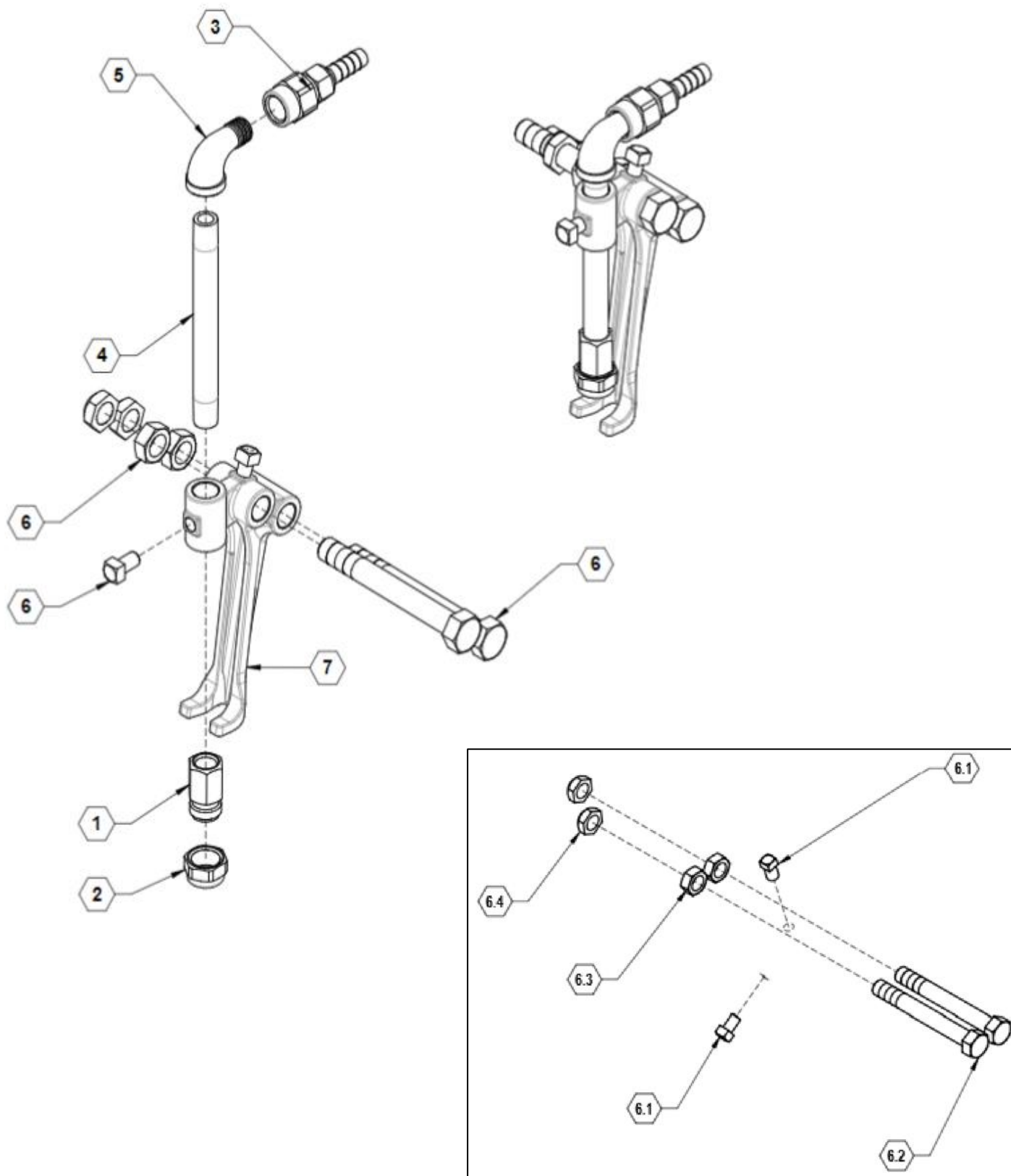

Parts List 90SAINJ: AP Coulter Injection Option Assembly

ITEM	PART NO.	QTY.	DESCRIPTION
1	520014	1	NOZZLE BODY, 1/4" SS
2	520015	1	NOZZLE CAP, SS
3	530188	1	CHECK VALVE ASSEMBLY
4	530199	1	PIPE NIPPLE, 1.4" SS
5	530246	1	ELBOW, 90° STREET 1/4 NPT SS
6	590818	1	HDWE KIT, INJECTION ASSY
6.1	596100M	2	SET SCREW, 3/8-16 X 1/2 MAGNI
6.2	596158M	2	BOLT, HH 1/2 X 4 GR5 MAGNI
6.3	596223M	2	NUT, HEX JAM 1/2 -13 MAGNI
6.4	596618M	2	NUT, TOPLOCK THIN 1/2-13 MAGNI
7	750089	1	CASTING, INJECTION ROCK GUARD

AP Coulter Blade Hardware Kit

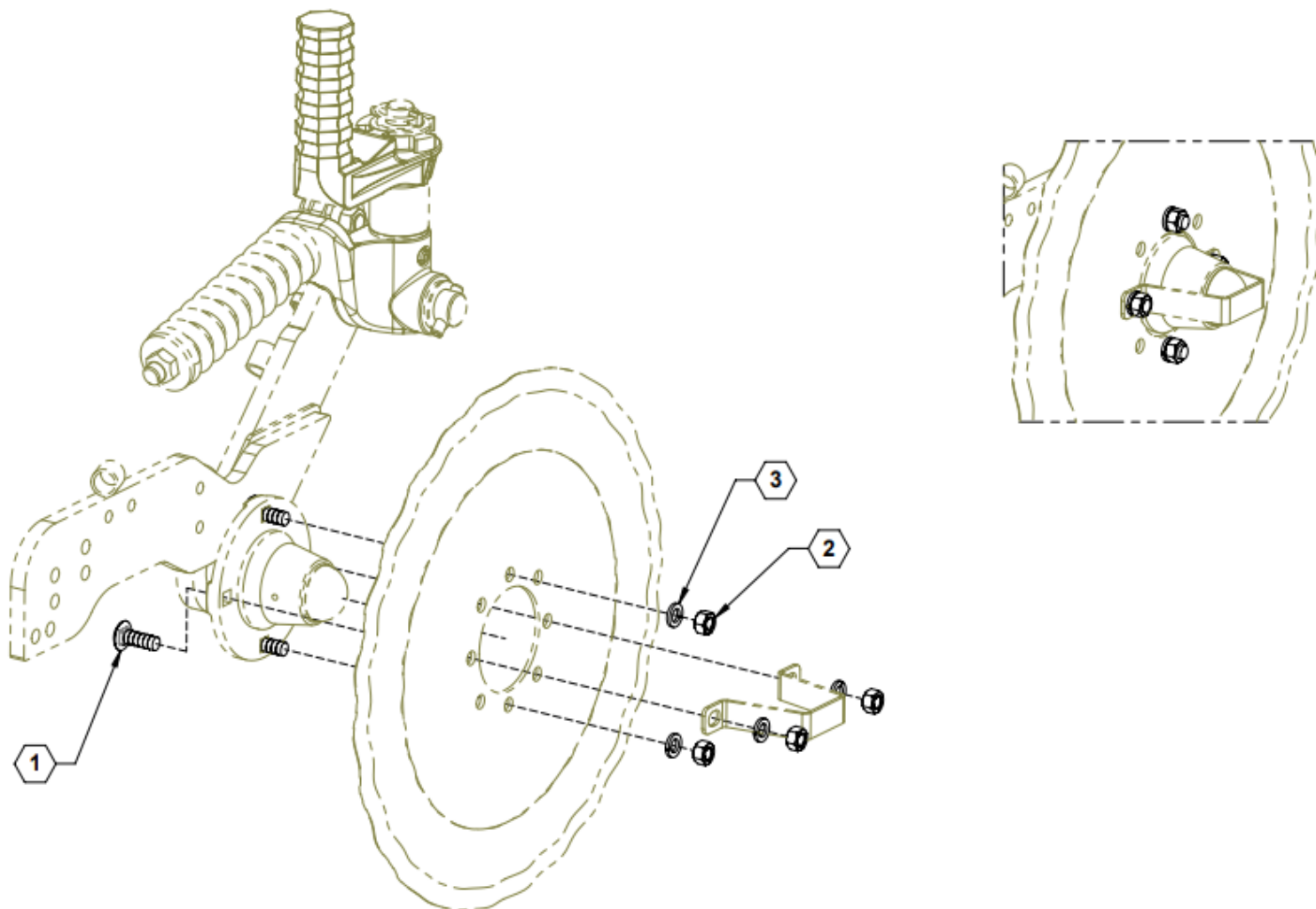

Parts List 590278: AP Coulter Blade Hardware Kit

ITEM	PART NO.	QTY.	DESCRIPTION
1	596620M	4	BOLT, CARR, 1/2 X 1-1/2 GR5 MAGNI
2	596215M	4	NUT, HEX 1/2 NC GR5 MAGNI
3	596251M	4	WASHER, LOCK, 1/2 MAGNI

DEFENDER® for Injection Assembly

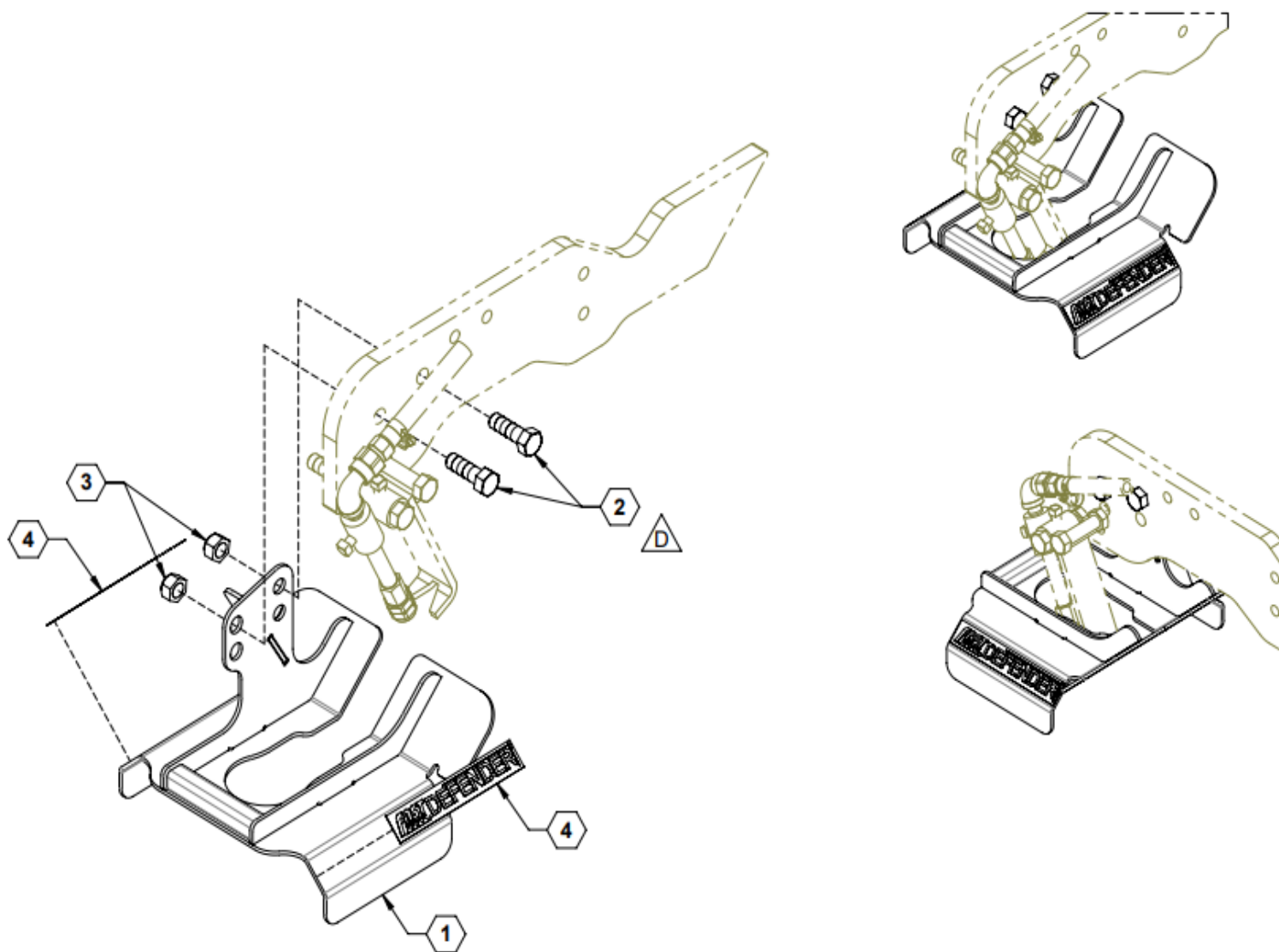

Parts List 99CROPDEFENDER: DEFENDER® for Injection

ITEM	PART NO.	QTY.	DESCRIPTION
1	21805	1	COULTER FENDER
2	596153M	2	BOLT, HH 1/2-13X1-1/2 GR5 MAGNI
3	596619M	2	NUT, TOPLOCK 1/2-13 MAGNI
4	800273	2	DECAL, FAST DEFENDER®

AP Coulter Knife High Flow Knife Option

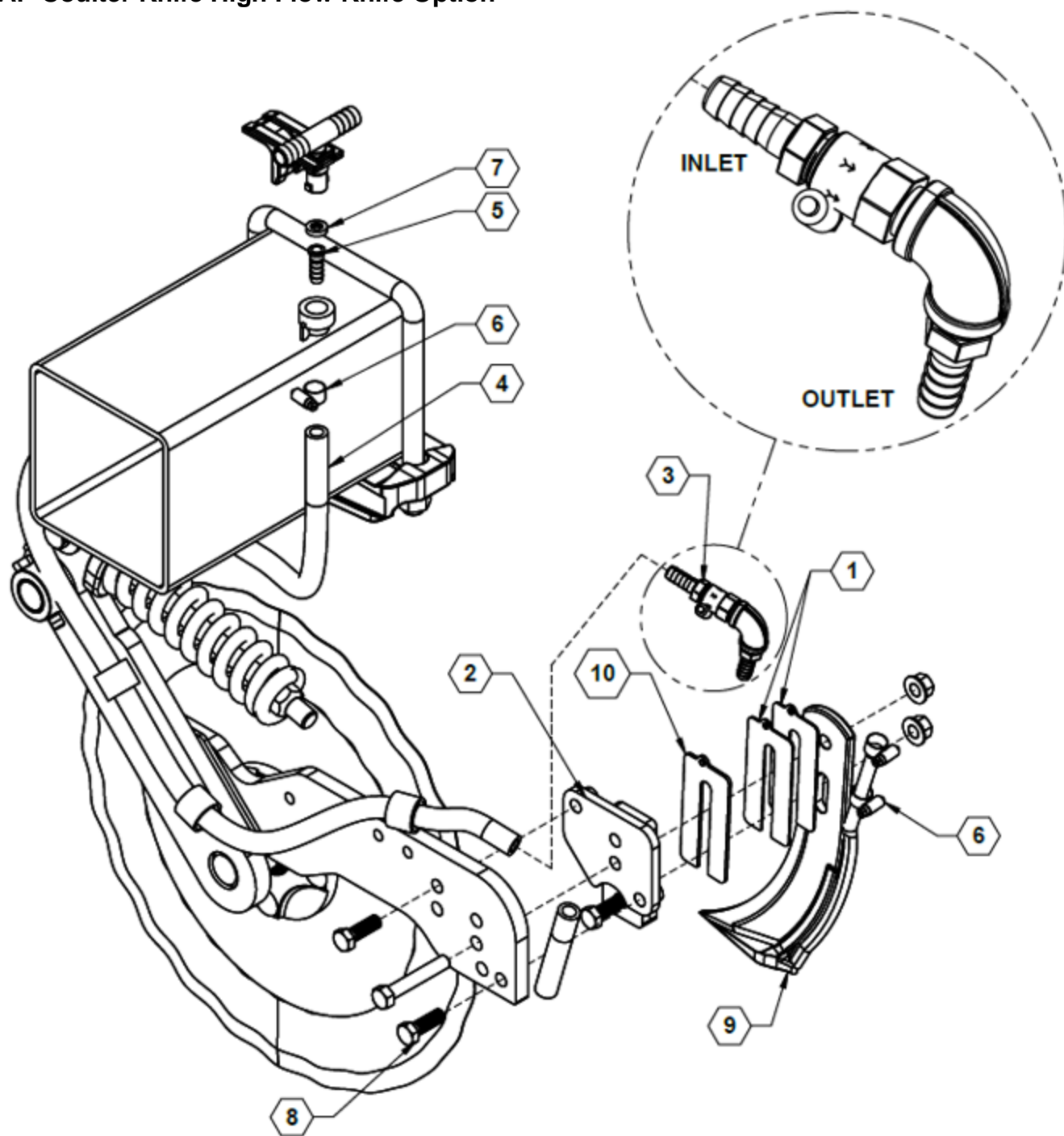

Parts List 37139: AP Coulter Knife High Flow Knife Option

ITEM	PART NO.	QTY.	DESCRIPTION
1	34474	2	KNIFE SHIM, 14 GA
2	34475	1	(PRE 2025) WELDMENT, KNIFE MOUNT
	790121	1	CASTING, KNIFE MOUNT
3	37138	1	HIGH FLOW CHECK ASS, KNIFE
4	510012	5 ft	HOSE, 1/2" EPDM
5	530526	1	CONNECTOR, HOSE BARB
6	540011	4	CLAMP, 3/8" #6H
7	590029	1	SEAL, EPDM
8	590799	1	HARDWARE KIT, KNIFE
9	750100	1	KNIFE, FERTILIZER 1/2"PIPE
10	34551	1	KNIFE SHIM, 11 GA

AP Coulters Knife Option Assembly – Non-Adjustable (2022 and newer, backwards compatible)

NOTES:

1. AFTER KNIFE IS PROPERLY ADJUSTED, SPIN BLADE TO ENSURE THE KNIFE MISSES THE BLADE; ADJUST AS NECESSARY

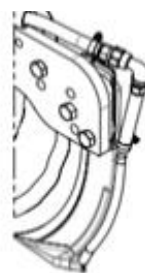
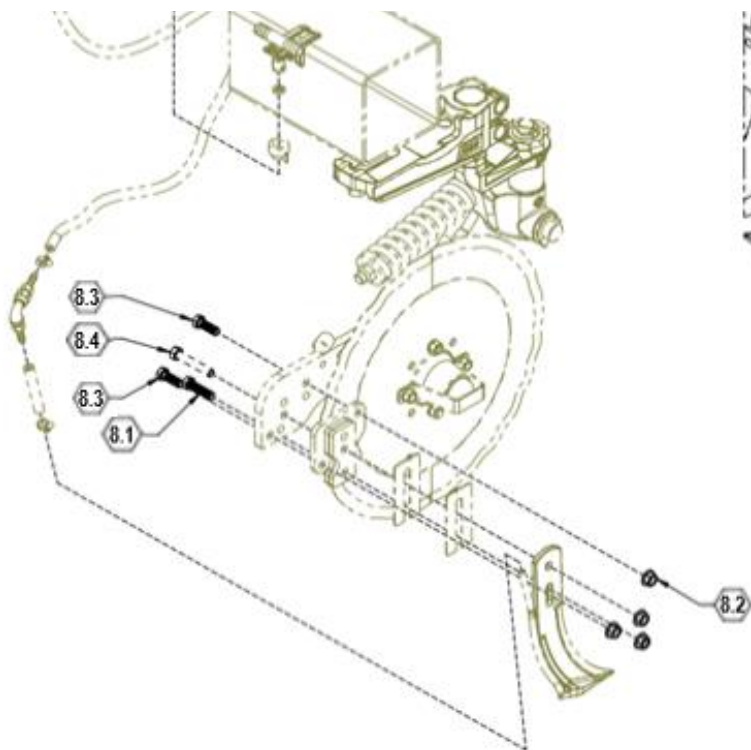
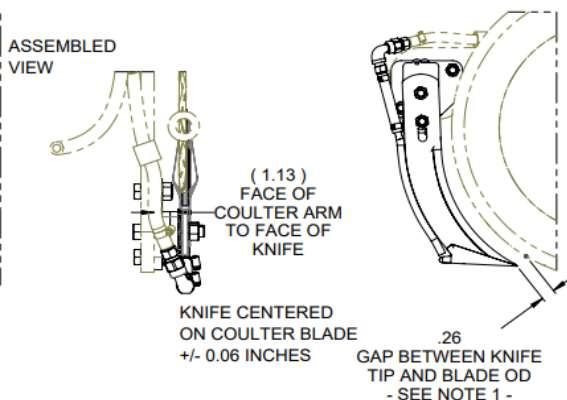
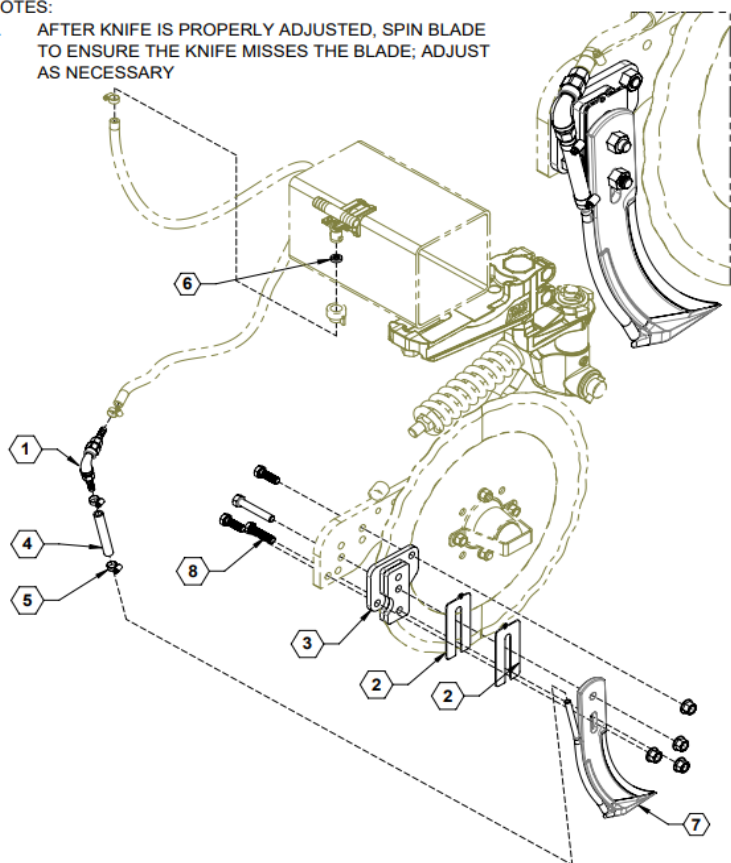

Parts List 34590: AP Coulter Knife Option Assembly – Non-Adjustable (2022 and newer, backwards compatible)

ITEM	PART NO.	QTY.	DESCRIPTION
1	90SACLYKNFCHCKVLV	1	KNIFE CHECK VALVE ASSEMBLY
2	34474	2	KNIFE SHIM, 14 GA
	34551	1	KNIFE SHIM, 11 GA
3	34475	1	(PRE 2025) WELDMENT, KNIFE MOUNT
	790121	1	CASTING, KNIFE MOUNT
4	510020	1	HOSE, 3/8" EPDM X .33FT
5	540032	2	CLAMP, HOSE SS 5/16" #5
6	590029	2	SEAL, EPDM
7	750003	1	KNIFE, EXTRA THIN W/ 3/8" PIPE
8	590799	1	HARDWARE KIT, KNIFE
8.1	596154M	1	BOLT, HH 1/2-13 X 2 GR5 MAGNI
8.2	596820M	4	NUT, FLANGED LOCKNUT, 1/2-13 G8 MAGNI
8.3	596853M	2	BOLT, 1/2"-13 X 1.5 GR. 8 MAGNI
8.4	596854M	1	BOLT, 1/2"-13 X 3" GR. 8 MAGNI

AP Coultter Knife Stop Hardware Kit – Adjustable (2022 and older)

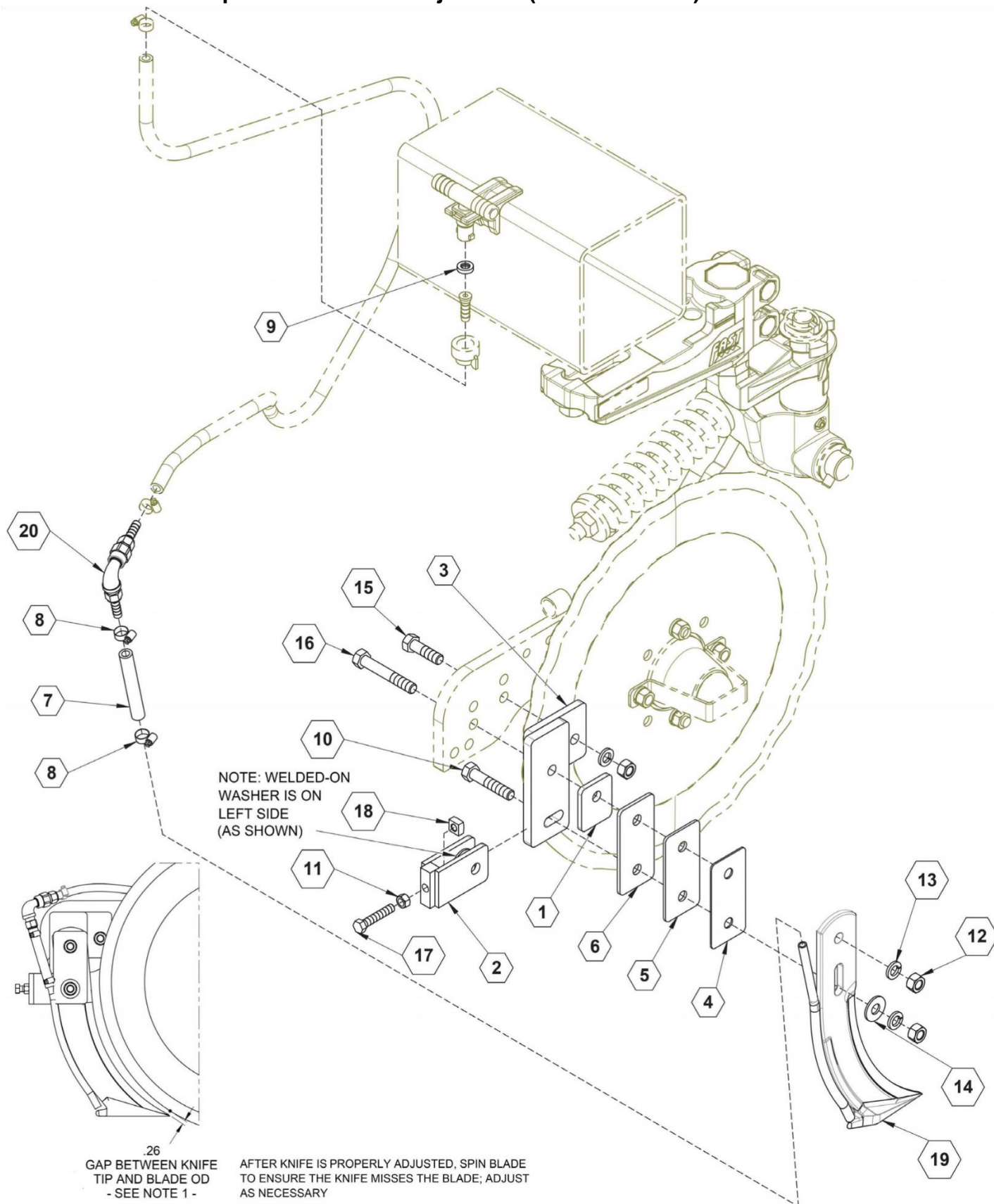

Parts List 99FCAPPKNIFE: AP Coulter Knife Stop Hardware Kit – Adjustable (2022 and older)

ITEM	PART NO.	QTY.	DESCRIPTION
1	17909	1	PLATE, SHIM SPACER
2	17910	1	KNIFE ADJUSTER BRACKET
3	17915	1	KNIFE MOUNT
4	17920	1	KNIFE SHIM, 14 GA
5	17921	1	KNIFE SHIM, 10 GA
6	17922	1	KNIFE SHIM, 7 GA
7	510020	1	HOSE, 3/8", EPDM
8	540032	2	CLAMP, HOSE SS 5/16" #5
9	590029	1	SEAL, EPDM
10	596155M	1	BOLT, HH 1/2-13 X 2-1/2 GR5 MAGNI
11	596213M	1	NUT, HEX 3/8-16 MAGNI
12	596215M	3	NUT, HEX 1/2 NC GR5 MAGNI
13	596251M	3	WASHER, LOCK, 1/2 MAGNI
14	596260M	1	WASHER, FLAT 1/2 MAGNI
15	596639M	1	BOLT, HH 1/2 X 1-3/4 GR5 MAGNI
16	596640M	1	BOLT, HH 1/2 X 3-1/4 GR5 MAGNI
17	596666M	1	BOLT, HH 3/8-16 X 2 MAGNI
18	596762M	1	NUT, SQ 3/8-16 MAGNI
19	750003	1	KNIFE, EXTRA THIN W/ 3/8" PIPE
20	90SACLYKNFCHCKVLV	1	KNIFE CHECK VALVE ASSEMBLY
NS	CP491663	AR	#63 ORIFICE DISK
NS	CP491665	AR	#65 ORIFICE DISK
NS	CP491672	AR	#72 ORIFICE DISK
NS	CP491675	AR	#75 ORIFICE DISK
NS	CP491677	AR	#77 ORIFICE DISK
NS	CP491678	AR	#78 ORIFICE DISK
NS	CP491680	AR	#80 ORIFICE DISK
NS	CP491689	AR	#89 ORIFICE DISK
NS	CP491691	AR	#91 ORIFICE DISK
NS	CP491693	AR	#93 ORIFICE DISK
NS	CP4916103	AR	#103 ORIFICE DISK
NS	CP4916107	AR	#017 ORIFICE DISK
NS	CP4916115	AR	#115 ORIFICE DISK
NS	CP4916125	AR	#125 ORIFICE DISK
NS	CP4916132	AR	#132 ORIFICE DISK
NS	CP4916144	AR	#144 ORIFICE DISK
NS	CP4916151	AR	#151 ORIFICE DISK
NS	CP4916177	AR	#177 ORIFICE DISK

Decal Assembly

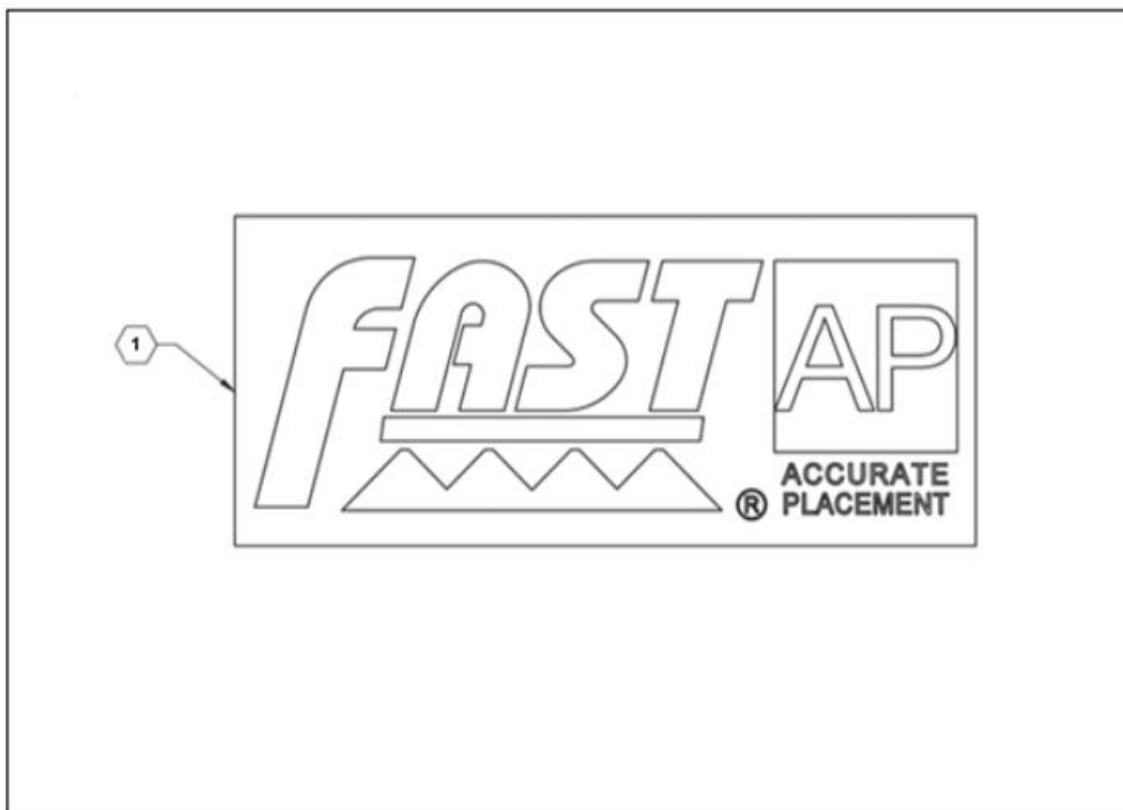

Parts List 17292: Decal Assembly

ITEM	PART NO.	QTY.	DESCRIPTION
1	800210	1	DECAL, FAST AP COULTER LOGO



FAST Ag Solutions
4130 Commerce Boulevard
Windom, MN 56101

1-800-772-9279 Toll Free
1-507-427-3861 Voice
1-507-427-3030 Fax

www.fastagsolutions.com