



**813P / 833P
LIQUID FERTILIZER APPLICATOR
PARTS MANUAL**





Limited Warranty

FAST AG SOLUTIONS warrants to the buyer that the new machinery is free from defects in material and workmanship.

This warranty is only effective as to any new machinery which has not been altered, changed, repaired or treated since its delivery to the buyer, other than by FAST AG Solutions or its authorized dealers or employees, and does not apply to accessories, attachments, tools or parts, sold or operated with the new machinery, if they have not been manufactured by FAST AG SOLUTIONS.

FAST AG SOLUTIONS shall only be liable for defects in the materials or workmanship attributable to faulty material or bad workmanship that can be proved by the buyer, and specifically excludes liability for repairs arising as a result of normal wear and tear of the new machinery or in any other manner whatsoever, and without limiting the generality of the foregoing, excludes application or installation of parts not completed in accordance with this operator's manual, specifications, or printed instructions.

Written notice shall be given by registered mail, to the Manufacturer within seven (7) days after the defect shall have become apparent or the repairs shall have become necessary, addressed as follows:

FAST AG SOLUTIONS
4130 Commerce Boulevard
Windom, MN 56101

This warranty shall expire one (1) year after the date of delivery of the new machinery.

If these conditions are fulfilled, FAST AG SOLUTIONS shall at its own cost and at its own option either repair or replace any defective parts provided that the buyer shall be responsible for all expenses incurred as a result of repairs, labor, parts, transportation or any other work, unless FAST AG SOLUTIONS has authorized such expenses in advance.

The warranty shall not extend to any repairs, changes, alterations, or replacements made to the new equipment other than by FAST AG SOLUTIONS or its authorized dealers or employees.

This warranty extends only to the original owner of the new equipment.

Rubber parts (including tires, hoses, grommets) are not warranted.

This warranty is limited to the terms stated herein and is in lieu of any other warranties whether express or implied, and without limiting the generality of the foregoing, excluded all warranties, express or implied or conditions whether statutory or otherwise as to quality and fitness for any purpose of the new equipment. The Manufacturer disclaims all liability for incidental or consequential damages.

This Applicator is subject to design changes and FAST AG SOLUTIONS shall not be required to retrofit or exchange items on previously sold units except at its own option.

Warranty void if not registered.



FAST LIQUID FERTILIZER APPLICATOR

Warranty Registration Form & Inspection Report

Warranty Registration

This form must be filled out by the dealer and signed by both the dealer and the customer at the time of delivery.

Form with fields for Customer Name, Address, City, State, Zip, Phone, Dealer Name, Address, City, State, Zip, Applicator Model, Serial Number, and Delivery Date.

DEALER INSPECTION REPORT

SAFETY

- ___ All Fasteners Tight
___ Wheel Bolts Torqued
___ Hydraulic Hoses and Fittings Free and Tight
___ Fertilizer Hoses and Fittings Free and Tight
___ Wheel Drive Turns Freely
___ Lubricate Machine
___ Check Tire Pressure
___ Frame and Wings Level
___ Monitors and Controllers Function
___ Wiring Harness Connected

- ___ Safety Chain Installed
___ All Guards Installed
___ All Safety Signs Installed
___ Reflectors, SMV and Lights Clean
___ Review Operating and Safety Instructions

I have thoroughly instructed the buyer on the above described equipment which review included the Operator's Manual content, equipment care, adjustments, safe operation and applicable warranty policy.

Date _____

Dealer's Rep. Signature _____

The above equipment and Operator's Manual have been received by me and I have been thoroughly instructed as to care, adjustments, safe operation and applicable warranty policy.

Date _____

Owner's Signature _____

White - Amity by FAST
Yellow - Dealer
Pink - Customer



FAST 813P / 833P SERIES APPLICATOR

APPLICATOR SERIAL NUMBER _____

DATE PURCHASED _____ / _____ / _____

NUMBER OF COULTERS _____

PUMP MANUFACTURER:

(CIRCLE ONE)

ACE 150F-206F

ACE 205F-304

Hypro 9306C-HMIC-MB

General Information

All rights, especially copying and distribution rights are reserved. No part of this publication may be reproduced in any form or by any means, electronic or mechanical, including photocopying, without express written permission from FAST AG Solutions.

Parts information in this manual represents components installed when product was manufactured based upon the best available information. Modifications made subsequent to initial delivery are not included. Always verify the parts and color required when ordering parts.

If you have any questions, please contact your FAST AG Solutions Parts and Service Department.

Parts Ordering Guide

1. Provide the Serial Number of your Chassis or System when ordering.
2. Use the Part Number and Description when ordering parts.
3. Provide the Page Title and Page Number if required.

Parts Searching Guide

To search this PDF by keyword, name, description or part number, use **ctrl + f** for simple searches or **ctrl + shift + f** for advanced searches.

Explanation of Parts Lists

The parts lists are broken down sub assemblies and listed in 4 columns:

- **ITEM** - These numbers are found on the illustration associated with the parts list.
 - o **NS** - This item is NOT SHOWN, included for reference.
 - o **QTY.** - This is the quantity of parts needed in an assembly.
 - o **AR** - The quantity of this item is AS REQUIRED for the location.
- **PART NO.** - These are the part numbers associated to the ITEM.
- **DESCRIPTION** - This is the description of the part.

Table of Contents

Section	Page
General Information	5
Table of Contents	6
Rear Hitch	9
Parts List 99HITCH3PTTB64 / 99HITCH3PTTB77: Rear Hitch	10
833P Center, Inner and Outer Wing Section	11
Parts List: 833P Center, Inner and Outer Wing Section	12
813P Center Section	13
Parts List: 813P Center Section	14
813P Inner and Outer Wing Section	15
Parts List: 813P Inner and Outer Wing Section	16
Gauge Wheel	17
Parts List 19062L/R / 26860 / 26861: Gauge Wheel	18
Q736 Hub Assembly, 5 Bolt	19
Parts List 730003: Q736 Hub Assembly, 5 Bolt	20
Mounting Clamp Kit for Auscherman Coultter Option	21
Parts List 750024 / 750046 / 750047: Mounting Clamp Kit for Auscherman Coultter Option	22
Auscherman Vantage II Coultter	23
Parts List: Auscherman Vantage II Coultter	24
Clymer Coultter Assembly	25
Parts List: Clymer Coultter Assembly	26
AP Coultter Assembly	27
Parts List 34471: AP Coultter Assembly	27
AP Coultter Base Assembly	28
Parts List 34470: AP Coultter Base Assembly	29
N669 Complete Hub with Square Hole with Triple Seal Assembly	30
Parts List 26891 / 730095ASSY: N669 Complete Hub with Square Hole with Triple Seal	30
AP Coultter Upper Casting Mounts	31
Parts List: AP Coultter Upper Casting Mounts	32
AP Coultter Injection Option Assembly	33
Parts List 90SAINJ: AP Coultter Injection Option Assembly	34
AP Coultter Blade Hardware Kit	35
Parts List 590278: AP Coultter Blade Hardware Kit	35
DEFENDER® for Injection Assembly	36
Parts List 17302 / 99CROPDEFENDER: DEFENDER® for Injection	36
AP Coultter Knife High Flow Knife Option	37
Parts List 37139: AP Coultter Knife High Flow Knife Option	38



ILLUSTRATED PARTS LIST

AP Coulter Knife Option Assembly–Non-Adjustable (2022 and newer, backwards compatible).....	39
Parts List 34590: AP Coulter Knife Option Assembly–Non-Adjustable (2022 and newer, backwards compatible).....	40
AP Coulter Knife Stop Hardware Kit – Adjustable (2022 and older)	41
Parts List 99FCAPPKNIFE: AP Coulter Knife Stop Hardware Kit – Adjustable (2022 and older).....	42
Decal Assembly	43
Parts List 17292: Decal Assembly.....	43
SMV and SIS	44
Parts List 90SASMV: SMV and SIS	45
Ace 150-206 Pump Hydraulic Motor	46
Parts List 550000: Ace 150-206 Pump Hydraulic Motor	46
Ace 150-206 Pump.....	47
Parts List 550000: Ace 150-206 Pump	47
Ace 304 Pump.....	48
Parts List 550035: Ace 304 Pump.....	48
ACE 150-206 Pump, Self Priming	49
Parts List 550043: ACE 150-206 Pump, Self Priming.....	50
Hypro Pump	51
Parts List 550011: Hypro Pump.....	52
Ball Valve Mount.....	53
Parts List: Ball Valve Mount	54
Toolbar Plumbing	55
Parts List: Toolbar Plumbing	55
Raven Components.....	56
Parts List: Raven Components	56
Control Harness 155-0171-085.....	57
Control Harness 155-0159-856.....	58
Control Harness 155-0171-086.....	59
Hydraulic System for Pump.....	60
Parts List: Hydraulic System for Pump	60
813P Hydraulic System	61
Parts List: 813P Hydraulic System	62
833P Hydraulic System	63
Parts List: 833P Hydraulic System	64
813P Hydraulic Schematic	65
Parts List: 813P Hydraulic Schematic	66
833P Hydraulic Schematic	67
Parts List: 833P Hydraulic Schematic	68
Lighting	69
Parts List: Lighting	69



Rear Hitch

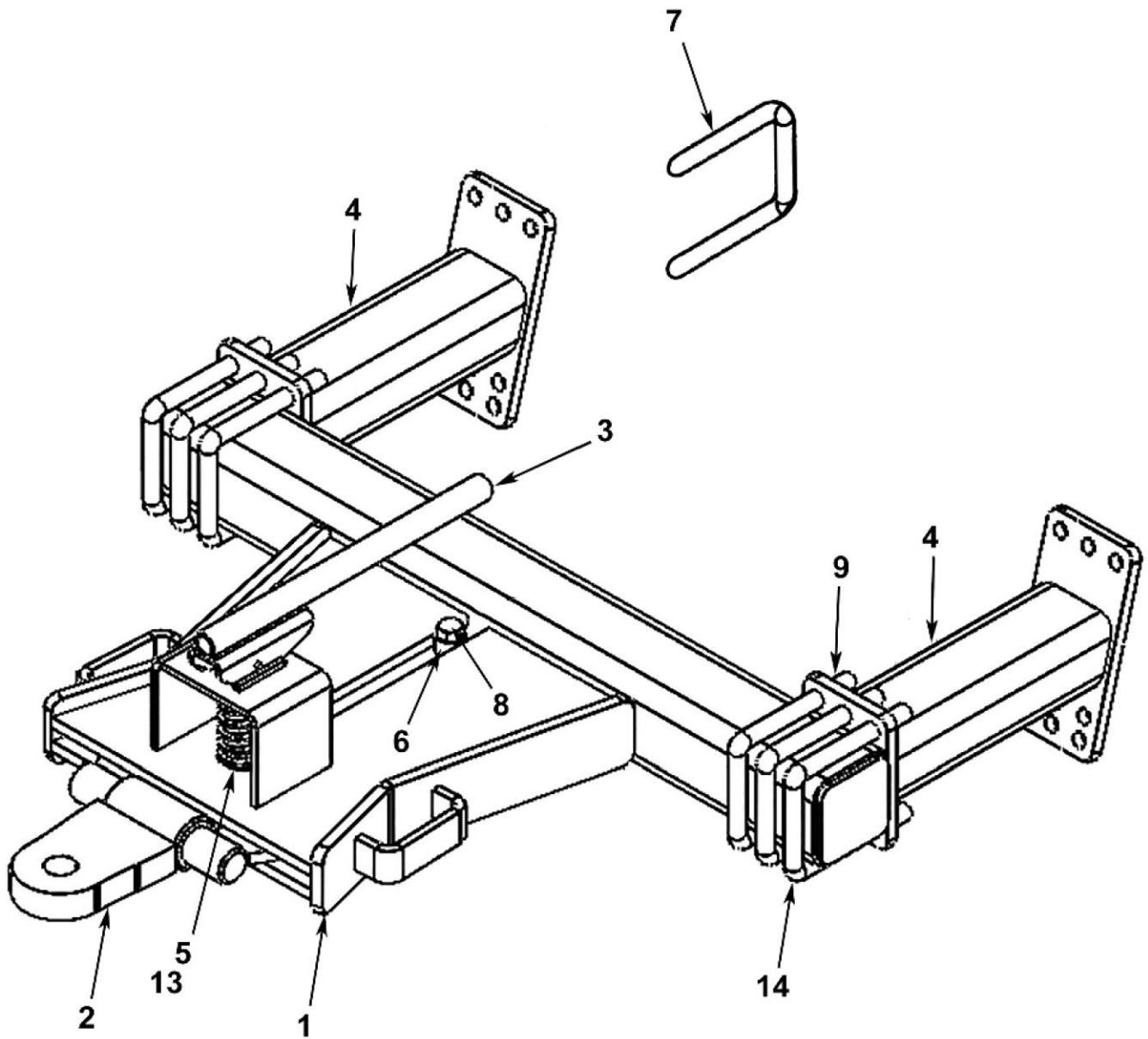

Parts List 99HITCH3PTTB64 / 99HITCH3PTTB77: Rear Hitch

ITEM	PART NO.	QTY.	DESCRIPTION
1	17851	1	HITCH, BOLT ON BASE
2	17852	1	SLIDER HITCH WELDMENT
3	17853	1	HANDLE, PIN LIFT
4	17854	2	EXTENSION, HITCH
5	17855	1	PIN, 7.00 LONG
6	17871	2	DOM, SPACER
7	17873	6	5/8" U-BOLT, 4 X 6 (813P)
7	590075	6	5/8" U-BOLT, 4 X 6, MAGNI (813P)
7	590108	6	5/8" U-BOLT, 7 X 7, MAGNI (833P)
8	596171M	1	HBOLT 0.6250-11 X 2.5 X 1.5-N
9	596216M	13	NUT. HEX, 5/8-11 MAGNI
10	709	1	PIN, SPRING, 3/4 X 2-1/2 ZP
11	790	1	BUSHING, MACH NR 1-1/4 X 10 GA
12	COTTER PIN	1	COTTER PIN 1/4" X 2-3/4
13	590195	1	SPRING, 4"
14	590186	6	UBOLT 5/8" 4X5-3/4 SQ. BEND

833P Center, Inner and Outer Wing Section

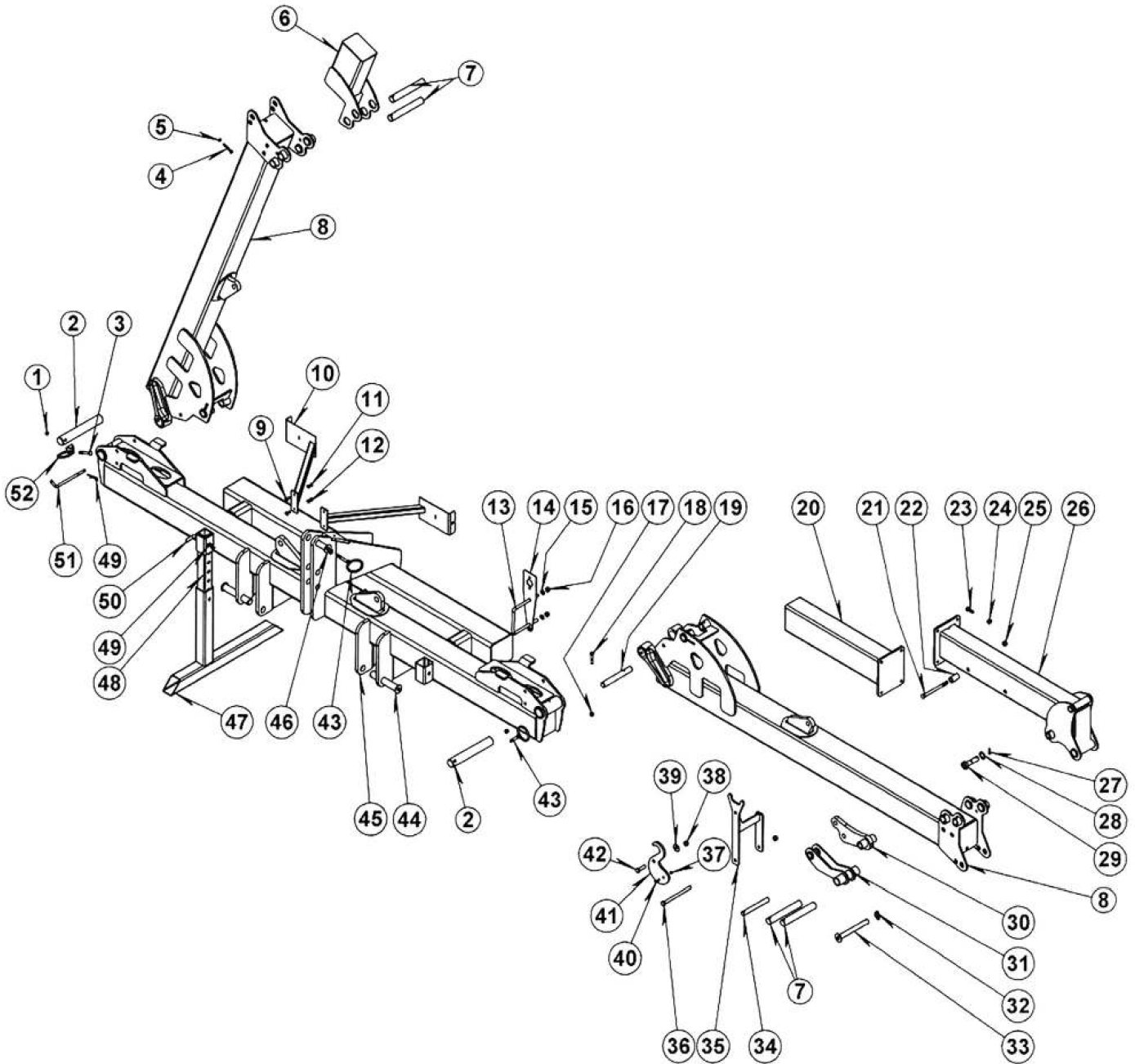

Parts List: 833P Center, Inner and Outer Wing Section

		PARTS BY # OF COULTERS ON BAR 30" ROWS				
ITEM	PART NO.	QTY.	QTY.	QTY.	QTY.	DESCRIPTION
		11	13	15	17	
1	237	2	2	2	2	NUT HH 1/2 CENTER LOCK ZP
2	17063	2	2	2	2	PIN, MAIN WING
3	257	2	2	2	2	BOLT HH 1/2 X 3-1/2 GR5 ZP
4	131		4	4	4	BOLT HH 3/8 X 2-1/2 GR5 ZP NUT HH 3/8 CENTERLOCK ZP
5	237		4	4	4	BOLT HH 3/8 CENTERLOCK ZP
6	17814		2			WING EXTENSION
7	17079		4	4	4	PIN, FLIP WING PIVOT
8	17053	2	2	2	2	WING, MAIN
9	590217	4	4	4	4	BOLT, CARRIAGE 3/8 X 1 ZP
10	17897	2	2	2	2	BRACKET, LIGHT
11	250	4	4	4	4	WASHER, LOCK 3/8 ZP
12	213	4	4	4	4	NUT HH 3/8 ZP
13	590108	2	2	2	2	U-BOLT 7 X 7 X 5/8 ZP
14	15836	2	2	2	2	MOUNT, 3PT TAIL LIGHT
15	253	4	4	4	4	LOCKWASHER 5/8 ZP
16	216	4	4	4	4	NUT, HEX HEAD 5/8
17	239	2	2	2	2	NUT HH 1/2 CENTER LOCK ZP
18	155	2	2	2	2	BOLT HH 1/2 X 2-1/2 GR5 ZP
19	17026	2	2	2	2	PIN, CYLINDER MAIN WING
20	17834				2	EXTENSION, FLIP WING
21	474			2	2	BOLT HH 5/8 X 7-1/2 GR5 ZP
22	17142			2	2	WING LOCK CATCH
23	153				8	BOLT HH 1/2 X 2 GR5 ZP
24	215				8	NUT HH 1/2 ZP
25	216			2	2	NUT HH 5/8 ZP
26	17170			2	2	WING, FLIP
27	700			2	2	PIN, ROLL 1/4 X 1-1/2
28	590179			2	2	WASHER, MACHINERY 1 X 14 GA
29	17060			2	2	PIN LINK CYLINDER
30	17076			2	2	LINK, FLIP WING, INNER
31	17080			2	2	LINK, FLIP WING, OUTER
32	710005			2	2	CLIP, QUICK LOCK
33	8339			2	2	PIN. WING LOCK
34	17083			2	2	PIN. FLIP WING LINKAGE
35	17887			2	2	STAND, FLIP WING LOCK
36	476			2	2	BOLT HH 5/8 X 8-1/2 GR5 ZP
37	236	2	2	2	2	NUT HEX 5/16 CENTERLOCK ZP
38	240			2	2	NUT HH 5/8 CENTERLOCK ZP
39	261			2	2	WASHER FLAT 5/8 ZP
40	115	2	2	2	2	BOLT HEX HEAD 5/16 X 1 GR5 ZP
41	17143			2	2	FLIP WING LATCH
42	170			2	2	BOLT HH 5/8 X 2 GR5 ZP
43	10327	2	2	2	2	HOLDER, HOSE
44	1226	2	2	2	2	PIN, LOWER 3PT
45	17165	1	1	1	1	TOOLBAR 3PT CENTER SECTION
46	1225	1	1	1	1	PIN, UPPER 3PT
47	16372	4	4	4	4	TUBE, HORIZONTAL BASE
48	16375	4	4	4	4	TUBE, HEIGHT ADJUSTMENT
49	590017	2	2	2	2	PIN, HAI PIN COTTER
50	1056	8	8	8	8	PIN, JACK STAND
51	17808	2	2	2	2	PIN LOCK TRANSPORT
52	17162	2	2	2	2	BRACKET, HOSE RING HOLDER

813P Center Section

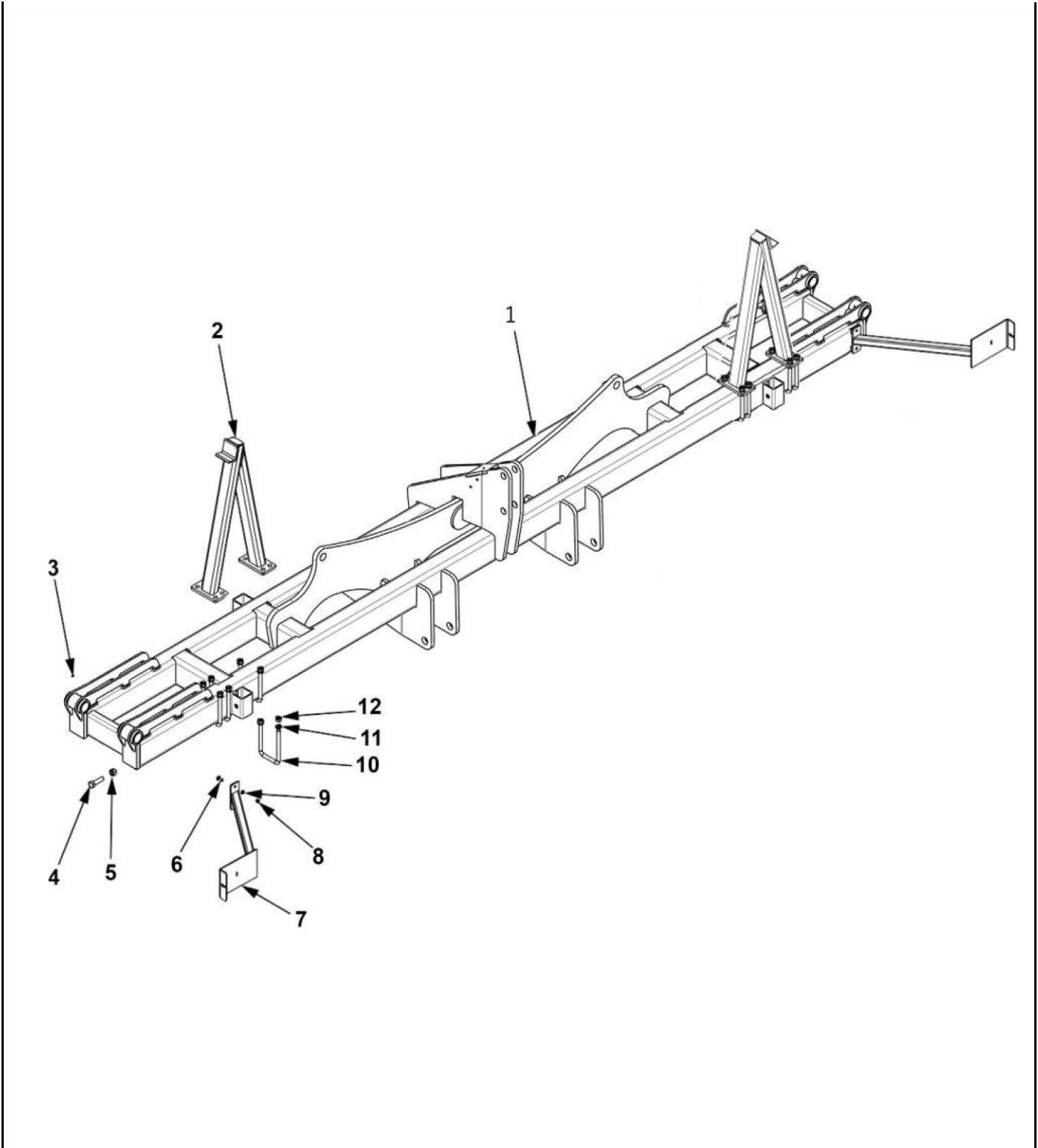

Parts List: 813P Center Section

ITEM	PART NO.	QTY.	DESCRIPTION
1	19350	1	CENTER SECTION 60' VERTICAL FOLD (813P)
2	16573	2	WINGSTAND
3	759	4	ZERK 1/4-28
4	185	4	BOLT HEX HEAD 3/4-2-1/2 GRADE 5 ZP
5	217	4	NUT HEX HEAD 3/4 ZP
6	590217	4	BOLT CARRAIGE 3/8 X 1 ZP
7	17897	2	LIGHT MOUNT VERTICAL FOLD TOOLBARS
8	250	4	WASHER LOCK 3/8 ZP
9	213	4	NUT HEX HEAD 3/8 ZP
10	590053	8	U-BOLT 5/8 X 4 X 6 SQUARE BEND
11	253	16	WASHER LOCK 5/8 ZP
12	216	16	NUT HEX HEAD 5/8 ZP

813P Inner and Outer Wing Section

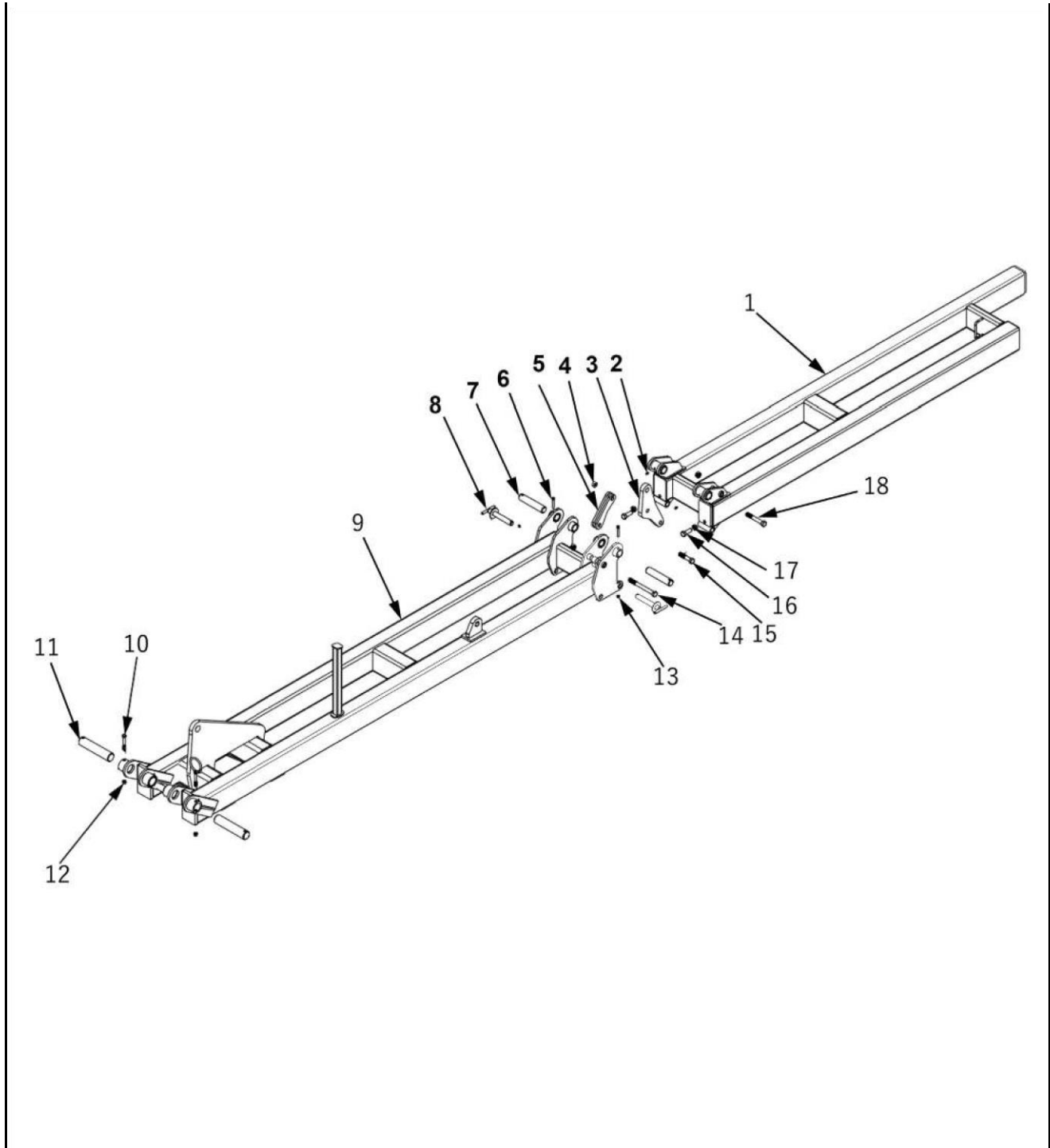

Parts List: 813P Inner and Outer Wing Section

ITEM	PART NO.	QTY.	DESCRIPTION
1	5503L	1	FLIP WING 60' DOUBLE BAR LH
2	5503R	1	FLIP WING 60' DOUBLE BAR RH
2	7598	4	ZERK 1/4-28ZP
3	5539	2	SCISSOR LINK 1" BOOMERANG
4	241	6	NUT HEX HEAD 3/4" CENTERLOCK ZP
5	5543	2	LINK FORK FOLDING
6	131	4	BOLT HEX HEAD 3/8 X 2-1/2 GRADE 5 ZP
7	5617	4	PIN HINGE 1-1/2
8	5743	4	TEE HANDLE LOCK PIN
9	13910L	1	WING MAIN 60' DOUBLE BAR LH
9	13910R	1	WING MAIN 60' DOUBLE BAR RH
10	157	4	BOLT HEX HEAD 1/2 X 3-1/2 GRADE 5 ZP
11	2120	4	PIN PIVOT MAIN WING
12	238	4	NUT HEX HEAD 1/2" CENTERLOCK ZP
13	237	4	NUT HEX HEAD 3/8" CENTERLOCK ZP
14	396	2	BOLT HEX HEAD 3/4 X 7-1/2 GRADE 8 ZP
15	386	2	BOLT HEX HEAD 3/4 X 3-1/2 GRADE 8 ZP
16	184	2	BOLT HEX HEAD 3/4 X 2 GRADE 5 ZP
17	225	4	NUT JAM 3/4 ZP
18	389	2	BOLT HEX HEAD 3/4 X 5 GRADE 8 ZP

Gauge Wheel

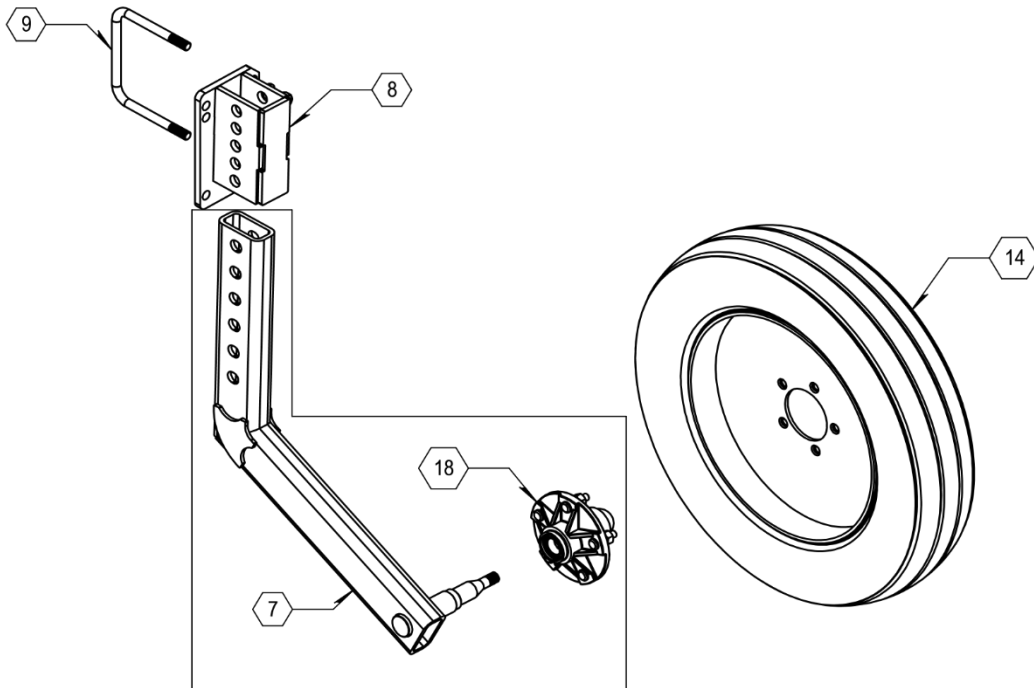
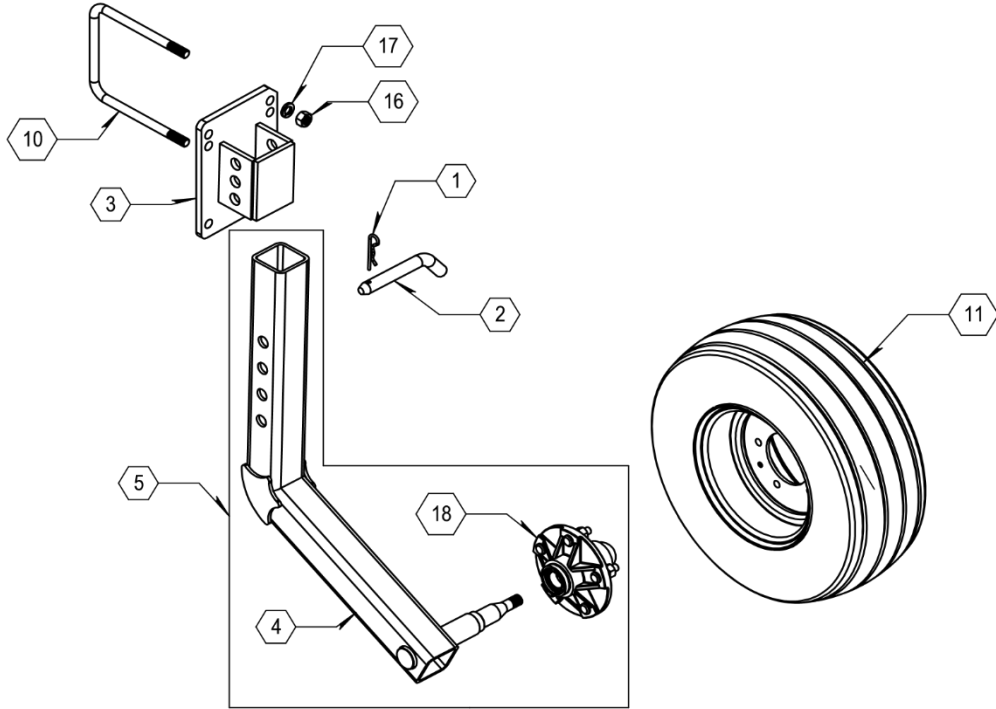

Parts List 19062L/R / 26860 / 26861: Gauge Wheel

ITEM	PART NO.	QTY.	DESCRIPTION
1	285	AR	PIN, HITCH, 1/8 X 3-1/8" ZP
2	19061	AR	PIN, CROSS
3	19055L	AR	STANDARD GAUGE WHEEL MOUNT
NS	19055R	AR	STANDARD GAUGE WHEEL MOUNT
4	19060L	AR	STANDARD GAUGE WHEEL ARM
NS	19060R	AR	STANDARD GAUGE WHEEL ARM
5	19063L	AR	STANDARD ARM WITH HUB
NS	19063R	AR	STANDARD ARM WITH HUB
6	22041L	AR	NARROW ARM WITH HUB
NS	22041R	AR	NARROW ARM WITH HUB
7	22045L	AR	NARROW GAUGE WHEEL ARM
NS	22045R	AR	NARROW GAUGE WHEEL ARM
8	22050L	AR	NARROW GAUGE WHEEL MOUNT
NS	22050R	AR	NARROW GAUGE WHEEL MOUNT
9	590061	AR	U-BOLT, 5/8 X 5 X 7"
10	590108	AR	U-BOLT, 5/8 X 5 X 7"
11	700023	AR	WHEEL, 20.5 X 8 X 10, YELLOW
12	700030	AR	WHEEL, 20.5 X 8 X 10, SILVER
13	700133	AR	NARROW WHEEL, SILVER
14	700134	AR	NARROW WHEEL, YELLOW
15	730030	AR	NUT, LUG
16	596216M	AR	NUT, HEX 5/8 MAGNI
17	596253M	AR	LOCKWASHER 5/8 MAGNI
18	730003 ASSY	AR	HUB ASSEMBLY

Q736 Hub Assembly, 5 Bolt

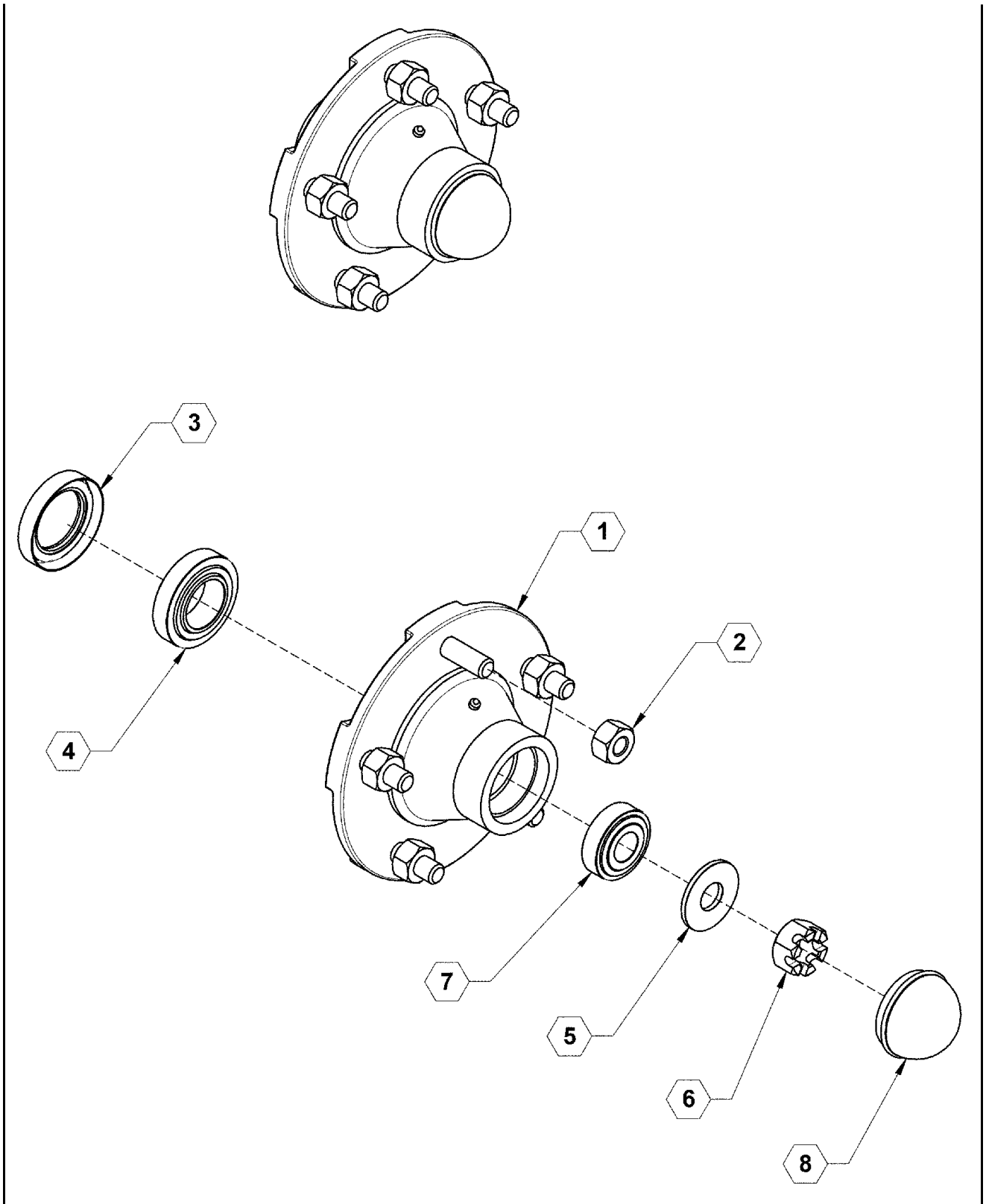

Parts List 730003: Q736 Hub Assembly, 5 Bolt

ITEM	PART NO.	QTY.	DESCRIPTION
1	730003	1	Q736 HUB ASSEMBLY (ITEMS 1-7)
2	1724	5	WHEEL STUD BOLT, 913576
2	1725	5	WHEEL LUG NUT, 912919
3	1716	1	SEAL QDS 906296
4	1710	1	INNER CUP (LM67010)
4	1712	1	INNER CONE (LM67048)
5	730034	1	HUB WASHER
6	730035	1	CASTLE NUT N669
7	1711	1	OUTER CUP (LM11910)
7	1713	1	OUTER CONE (LM11949)
8	1714	1	HUB CAP QDS 909931

Mounting Clamp Kit for Auscherman Coulter Option

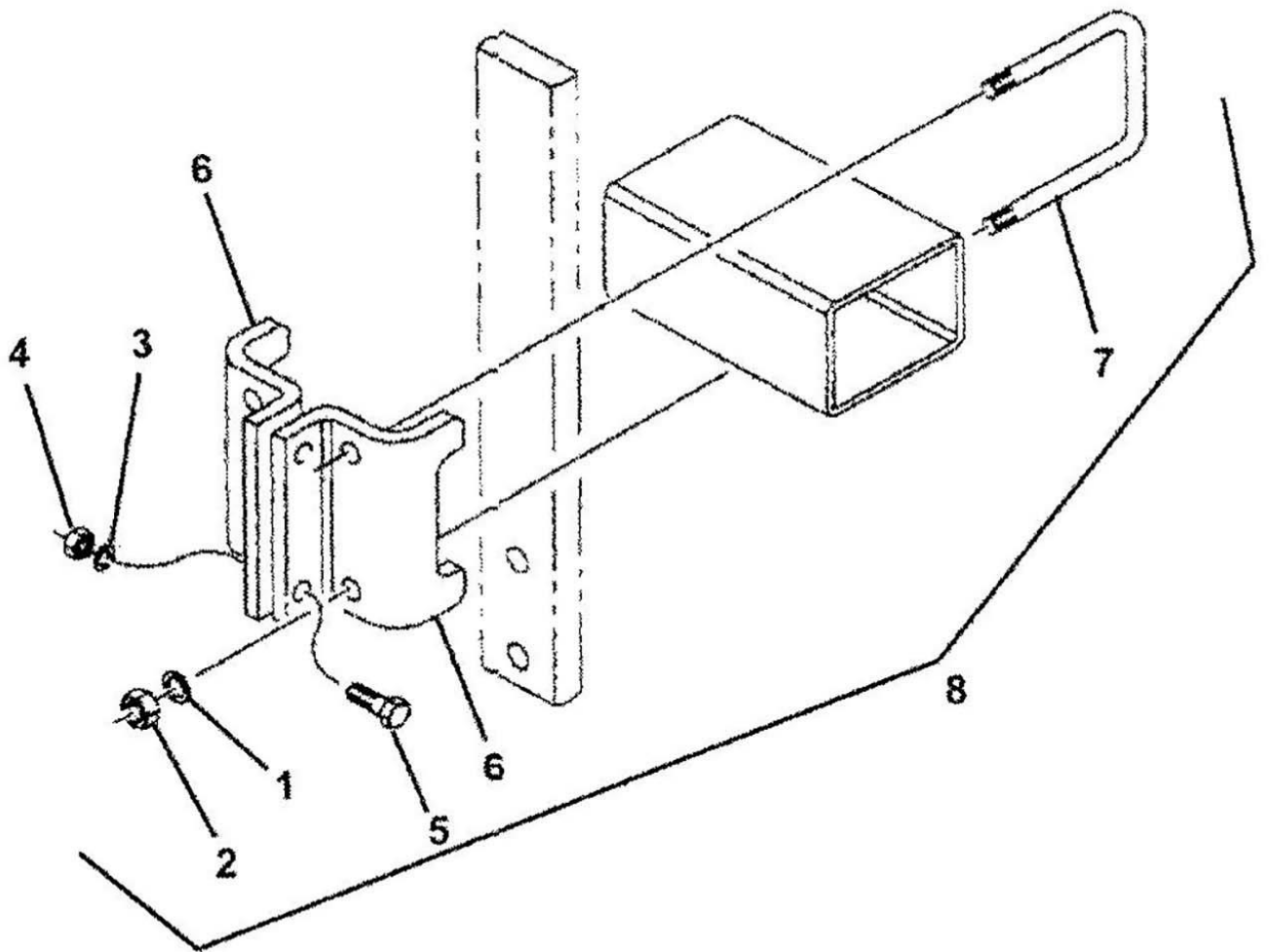

Parts List 750024 / 750046 / 750047: Mounting Clamp Kit for Auscherman Coulter Option

ITEM	VENDOR PART NO.	FAST PART NO.	QTY.	DESCRIPTION
1	804-022C	253	4	LOCKWASHER 5/8" ZP
2	803-021C	216	4	NUT HEX 5/8 ZP
3	804-015C	252	2	LOCKWASHER 1/2" ZP
4	803-020C	215	2	NUT HEX 1/2" ZP
5	802-091C	153	2	BOLT HEX HEAD 1/2 X 1-1/2 GR5 ZP
6	204-188D		AR	6" SPLIT BAR CLAMP
6	204-189D		AR	7" SPLIT BAR CLAMP
7	806-116C		AR	U-BOLT 6 X 4 X 5/8, USE WITH 204-356K
7	806-083C		AR	U-BOLT 5/8-11 X 7 1/32 X 7 1/2, USE WITH 204-228K
7	806-084C		AR	U-BOLT 5/8-11 X 7 1/32 X 9 1/2, USE WITH 204-224K
7	806-131C		AR	U-BOLT 5/8-11 X 7 1/32 X 6, USE WITH 204-243K
8	204-356K	750024	1	6 X 4 BAR CLAMP KIT
8	204-224K	750046	1	7 X 7" SQUARE BAR CLAMP KIT
8	204-228K	750047	1	7 X 5" SQUARE BAR CLAMP KIT

Auscherman Vantage II Coulter

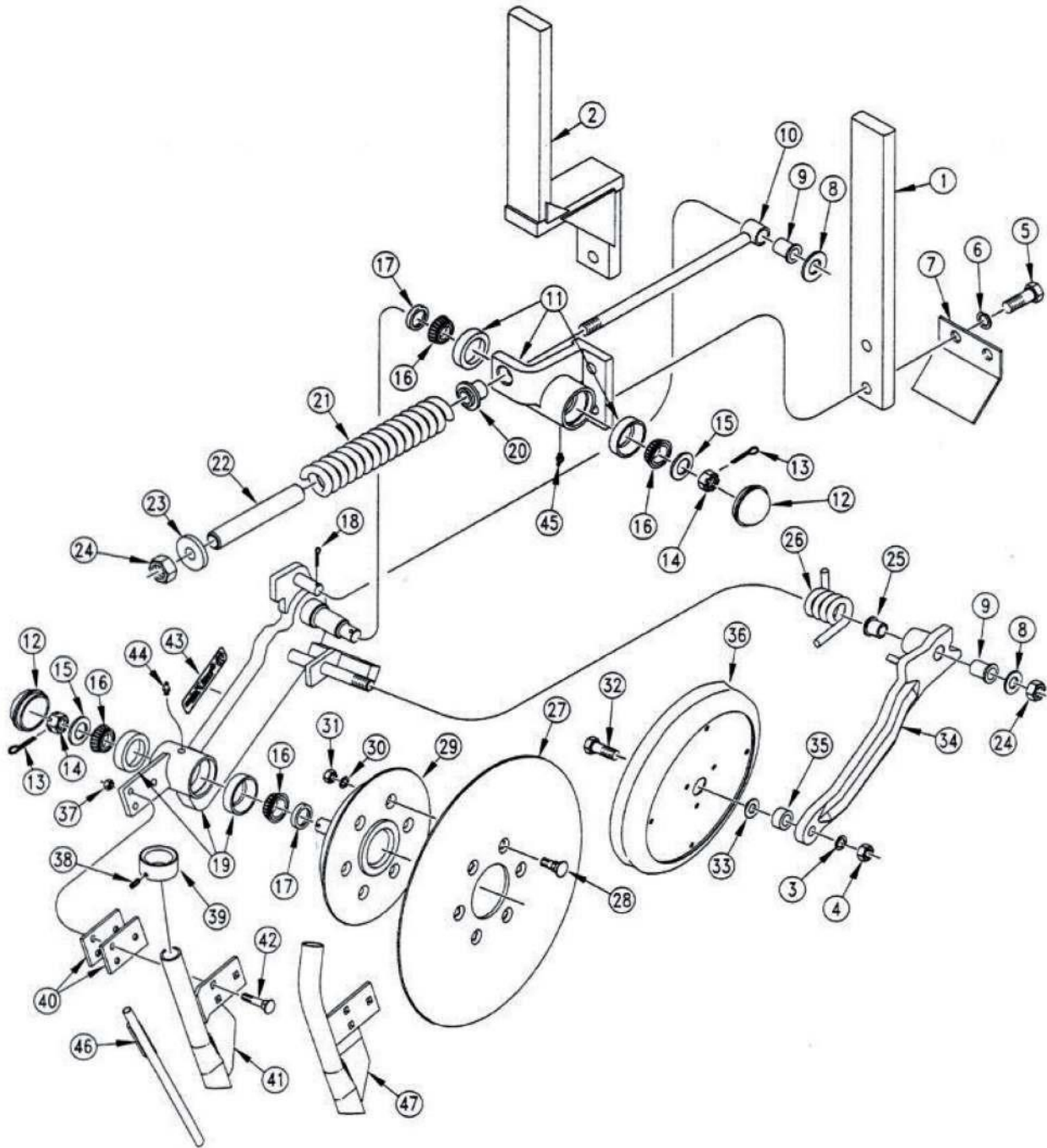

Parts List: Auscherman Vantage II Coultter

ITEM	VENDOR PART NO.	FAST PART NO.	DESCRIPTION
1	807-124C	750026	21" FLAT BAR ANGLED COULTER SHANK
2	820-181C		VANTAGE II 5" OFFSET FLAT SHANK RH (SHOWN)
NS	820-182C		VANTAGE II 5" OFFSET FLAT SHANK LH
NS	804-022C		WASHER LOCK SPRING 5/8
NS	803-021C		NUT HEX 5/8-11 PLT
5	802-064C		HEX HEAD CAP SCREW 3/4-10 X 2 GRADE 5
6	804-023C		WASHER LOCK SPRING 3/4
7	204-154D		FRONT SHIELD
8	804-025C		WASHER FLAT 3/4 SAE
9	817-051C		SWING ARM BUSHING
10	204-209H		BLADE SPRING ROD WELDMENT
11	204-233V		COULTER PIVOT RH SUB-ASSEMBLY (SHOWN)
	204-235V		COULTER PIVOT LB SUB-ASSEMBLY
12	200-001D		HUB GREASE CAP
13	805-017C		PIN COTTER 3/16 X 1-3/4
14	803-029C		NUT HEX SLOTTED 7/8-14
15	804-05 5C		WASHER SPINDLE -7/8
	822-020C		BEARING CUP LM -67010 (NOT SHOWN)
16	822-021C		BEARING CUP LM -67048
17	816-009C		OIL SEAL DOUBLE LIP
18	805-063C		PIN COTTER 3/23 X 1 LONG
19	204-234V		BLADE ARM RH SUB-ASSEMBLY (SHOWN)
	204-236V		BLADE ARM LH SUB-ASSEMBLY
20	817-029C		BUSHING COULTER CASTING
21	807-074C		SPRING 2.25 OF X .5 COIL
22	204-107D		SPRING ROD SLEEVE 1-1/8 OD
23	812-031C		CASTING COULTER SPRING WASHER
24	803-025C		NUT HEX 3/4-10 OLT NYLOCK
25	817-084C		PARALLEL ARM PIVOT BUSHING
26	807-089C		TORSION SPRING 3/8 WIRE RH (SHOWN)
	807-090C		TORSION SPRING 3/8 WIRE LH PLOW BOLT 1/2-13 X 1-1/2 GRADE 5
27	820-093C		SINGLE BEVEL 18 COULTER BLADE
28	802-354C		PLOW BOLT 1/2-13 X 1-1/2 GRADE 5
29	204-145D		COULTER HUB
30	804-015C		WASHER LOCK SPRING 1/2
31	803-020C		NUT HEX 1/2-13
32	802-281C		HEX HEAD CAP SCREW 5/8-11 X 2-3/4 GRADE 5
33	804-019C		WASHER FLAT 5/8 USS
34	201-141D		WIPER WHEEL ARM RH (SHOWN)
	204-142D		WIPER WHEEL ARM LH
35	204-153D		WIPER WHEEL SPACER
36	198-057S		2 X 13 DEPTH WHEEL ASSEMBLY
	822-095C		PRESS WHEEL BEARING ONLY
	814-083C		PRESS WHEEL TIRE ONLY
37	803-013C		NUT LOCK 3/8-16 PLT
38	801-015C		SCREW SET SOCKET HEAT 1/4-20 (1/2)
39	204-268D		DRY FERTILIZER TUBE COLLAR
40	816-134C		RUBBER PAD
41	820-124C		DRY FERTILIZER TUBE RH
	820-125C		DRY FERTILIZER TUBE LH
42	802-406C		RHSNB 3/8-16 (1-3/4 SS)
43	838-482C		DECAL GP PLANTING COMPONENTS
44	800-001C		GREASE ZERK STRAIGHT 1/4-28
45	800-073C		GREASE ZERK 1/4-28 X 90°
46	890-580C		VANTAGE II LIQUID INSERT
47	204-412H	750025	VANTAGE II RH DRY DROP TUBE WELDMENT (SHOWN)
	204-413H		VANTAGE II LH DRY DROP TUBE WELDMENT
	204-218L	750022	COULTER VANTAGE II RH (INCL 8-45,47
	204-219L	750023	COULTER VANTAGE II LH (INCL 8-45,47 LH)

Clymer Coultter Assembly

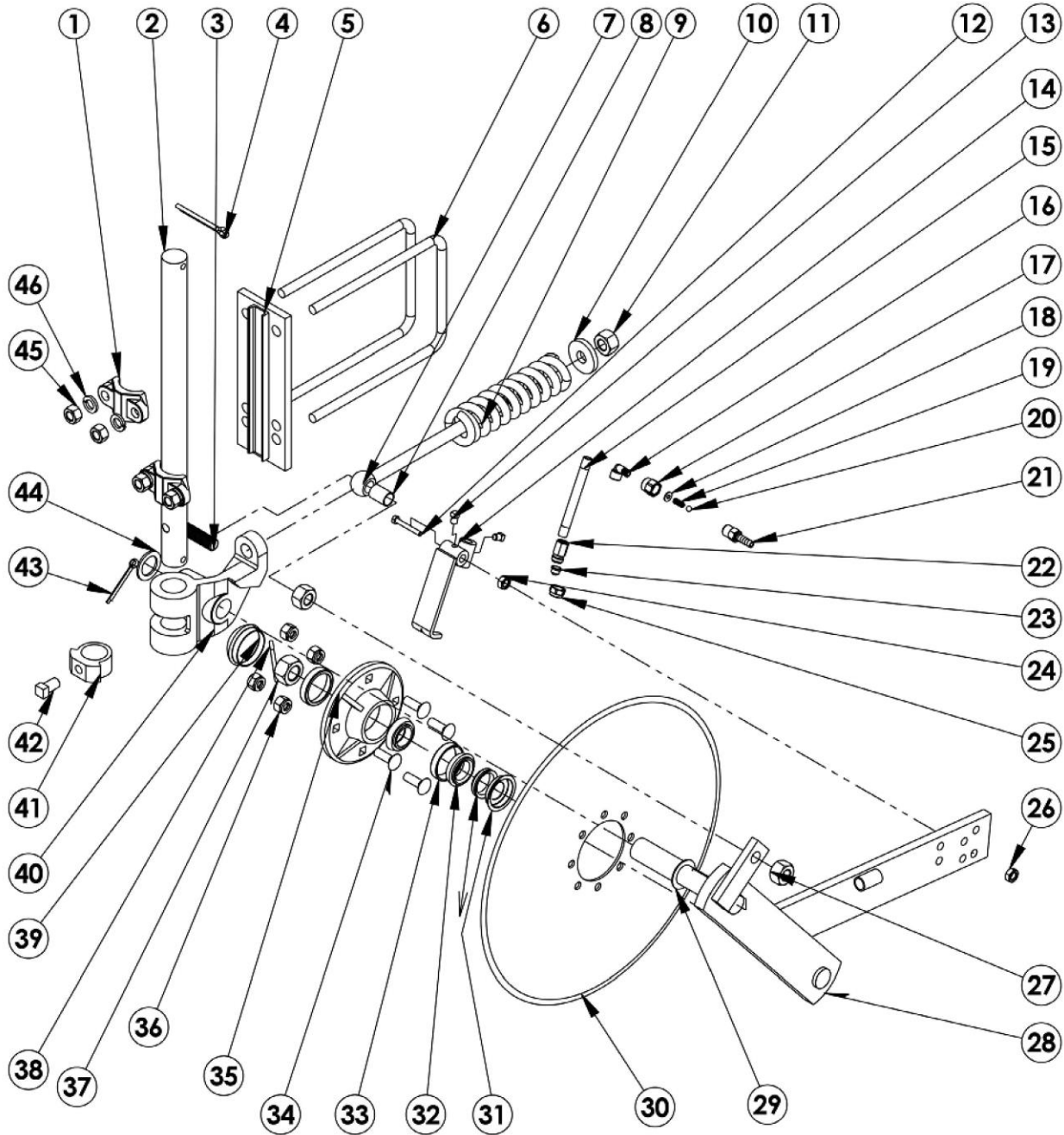



ILLUSTRATED PARTS LIST

Parts List: Clymer Coultter Assembly

ITEM	VENDOR PART NO.	FAST PART NO.	QTY.	DESCRIPTION
1	N369	590005	2	CASTING CLAMP
2	N343	750012	1	1-1/2" STRAIGHT COULTER SHANK
NS	N345	750055	AR	1-1/2" OFFSET COULTER SHANK
NS		750054	1	1-1/2" OFFSET COULTER SHANK SPECIAL
NS		750053	1	1-1/2" OFFSET COULTER SHANK SPECIAL
3		186	1	BOLT HEX HEAD 3/4 X 3 GRADE 5 ZP
4	FPC510		2	COTTER PIN 5/16" X 3
5	N367-1		1	CLAMP PLATE
6	FBU6B0		2	U-BOLT 7 X 8-1/2 X 5/8 E-COAT
7	N347-7		1	BUSHING NYLON FOR SPRING ROD
8	N347-5		1	SPRING ROD
9	S233		1	SPRING COULTER
10	N347-3		1	SPRING BUSHING CASTING
11		233	1	NUT HEX HEAD 3/4 NYLOCK ZP
12	FBH0816-SS	750010	1	BOLT HEX HEAD 1/2 X 4 GRADE 5 SS
13	FBS0602	750018	2	SET SCREW 3/8 X 1/2"
14	COI100-7	750016	1	ROCK GUARD
15	TJ-4676-22-1/4	530199	1	NIPPLE, PIPE 1/4 X 5 SS
16	TJ-CP4916-250	530246	1	ELBOW, STREET 1/4" NPT SS
		530188	1	HOSE SHANK CHECK VALVE ASSEMBLY ITEMS 17-21
17	TJ-4676-22-1/4		1	ADAPTER 11/16" X 1/4" NPT
18	TJ-CP4916-250		1	ORIFICE PLATE 302 SS
19	TJ-CP3655-5-SS		1	SPRING 5# 302 SS
20	TJ-CP7671-5/16/SS		1	BALL 302 SS
21	TJ-39189-8400-406-SS		1	HOSE SHANK 11/16 X 1/4" NPT 303 SS
22	TJ-CP1321-SS	520014	1	TEEJET BODY SS
23	TP-00XX-SS		1	TIP SS TEEJET (SPECIFY TIP SIZE)
24	FNJ08-SS	750009	1	HUT HEX HEAD JAM 1/2" SS
25	TJ-CP1325SS	750015	1	NOZZLE CAP SS
26	FNJL08-SS	750011	1	NUT HEX HEAD NYLOCK 1/2" SS
27	FNL12-NF		1	NUT HEX HEAD 3/4" NF ZP
28	N347-47		1	SWING ARM W HUB
29	N347-6		1	BUSHING COULTER FLANGED
30	N342	750014	1	COULTER RIPPLE 20"
31	W40-2		1	SEAL COULTER 2 PIECE
32	W32		1	BEARING
33	W38		2	CUP
34	FBC0806		2	BOLT CARRIAGE 1/2" X 1-1/2" ZP
35	W23Y		4	HUB ASSEMBLY COMPLETE (ITEMS 32-33, 35, 39)
	W23		1	HUB ONLY
36	FNH08		1	NUT HEX HEAD 1/2" ZP
37	W60		4	NUT SPINDLE 5/8"
38	FPC497		1	PIN COTTER 1/8" X 1-1/4"
39	W50		1	CAP HUB
40	N347-1		1	COULTER HINGE CASTING
41	N347-2	750008	1	LOCKING COLLAR 30°
NS	N347-2/45		OPT.	LOCKING COLLAR 45°
42	FBS1004		1	SETSCREW 5/8" X 1"
43	FPC505		1	PIN COTTER 1/8" X 1-1/4"
44	FWM18		1	BUSHING 1/8" THICK
45		216	4	NUT HEX HEAD 5/8" ZP
46		253	4	WASHER LOCK 5/8"

AP Coultter Assembly

- NOTE:
 1. 7X7 TOOLBAR SHOWN FOR REFERENCE. 7X5 & 6X4 NOT SHOWN
 2. TORQUE U-BOLT TO 260 FT-LBS +/- 10 FT-LBS

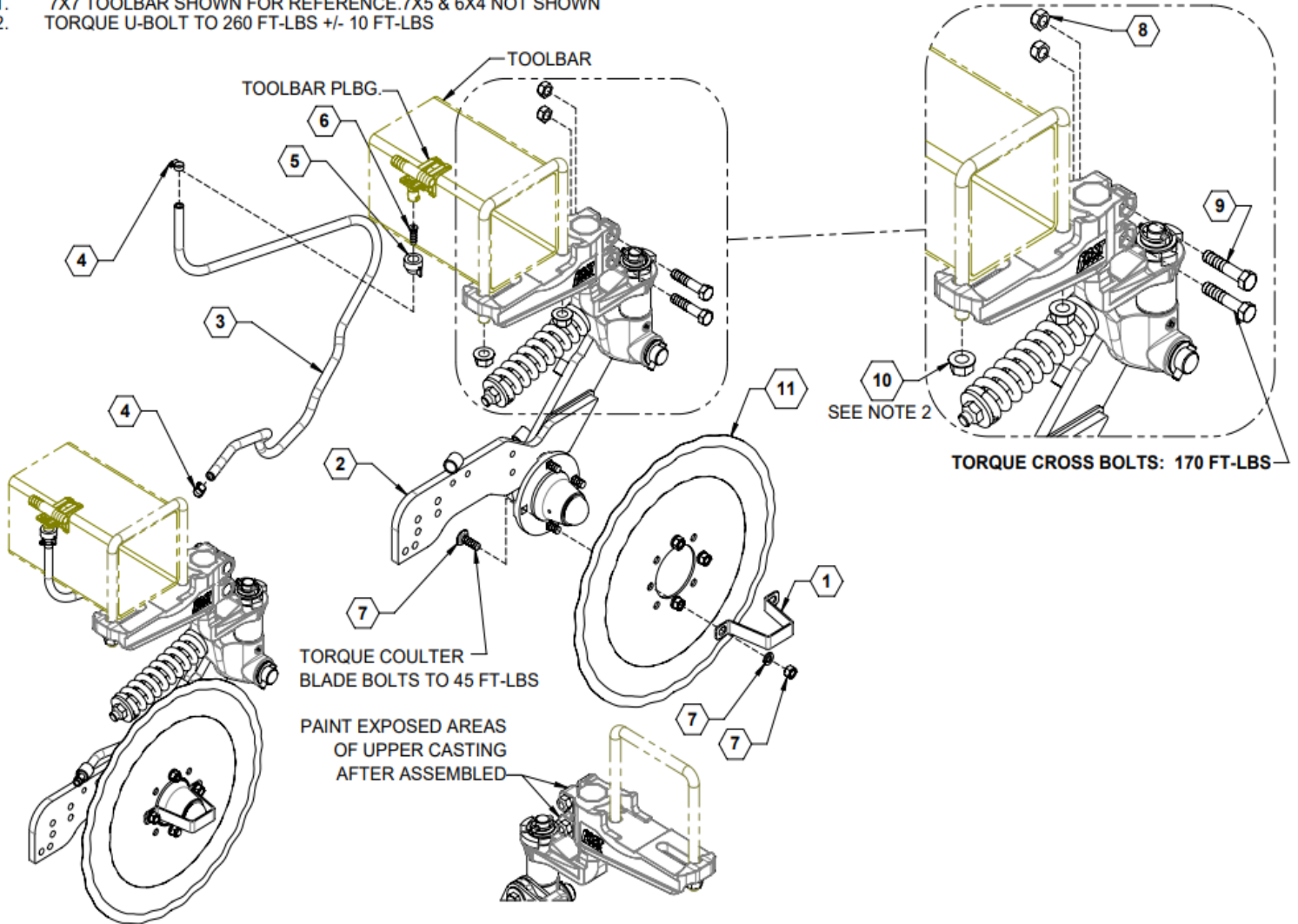

Parts List 34471: AP Coultter Assembly

ITEM	PART NO.	QTY.	DESCRIPTION
1	17214	1	HUB RETAINER BRACKET
2	34470	1	ASSY, UPDATED COULTTER BASE
3	510020	1	HOSE, 3/8" EPDM X 4.5 FT
4	540032	2	CLAMP, HOSE SS 5/16" #5
5	590076	1	CAP, QT NYLON BLACK
6	590077	1	CONNECTOR, HOSE BARB
7	590278	1	HDWE KIT, COULTTER BLADE KIT
8	596243M	2	NUT, TOPLOCK 5/8-11 G8 MAGNI
9	596779M	2	BOLT, HH 5/8 X 3 G8 MAGNI
10	596850M	2	NUT, HEX FLANGE TOPLOCK 3/4-10 GR8 MAGNI
11	750014	1	COULTTER BLADE, 20' RIPPLED

AP Coulter Base Assembly

NOTE:

1. SET SPRING LENGTH AS SHOWN ON DRAWING
2. TIGHTEN BOLT UNTIL PLATES DEFLECT .06" +/- .03" MAKING SURE LOCK NUT FULLY ENGAGES ON BOLT
3. PAINT EXPOSED PIVOT SHAFT AFTER ASSEMBLED

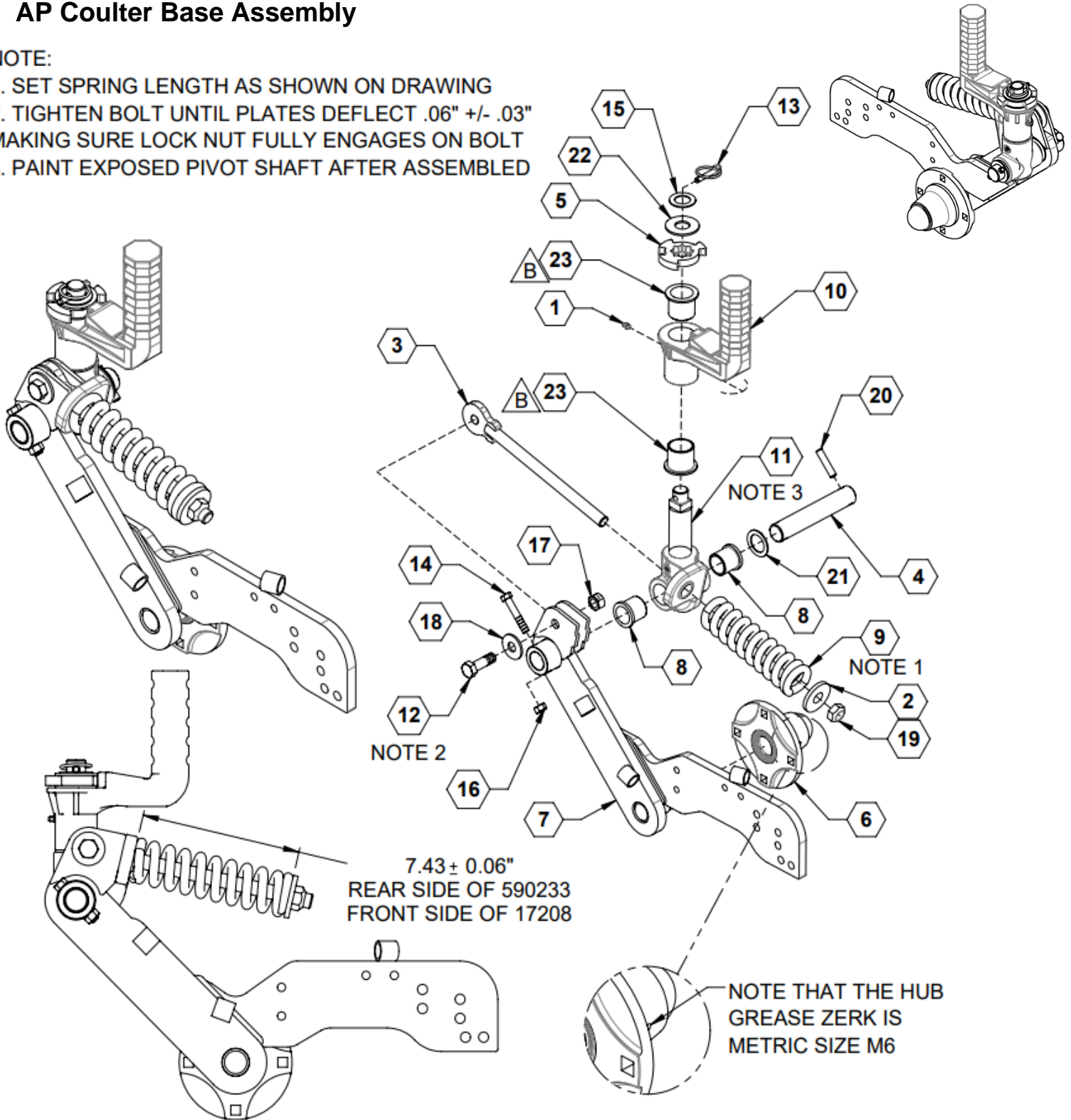

Parts List 34470: AP Coultter Base Assembly

ITEM	PART NO.	QTY.	DESCRIPTION
1	759	1	ZERK, 1/4-28 STRAIGHT PIPE THREAD
2	17208	1	PLATE, SPRING END
3	17276	1	SPRING LEVER WELDMENT
4	17291	1	PIVOT SHAFT
5	21088	1	PLATE, COULTER ROTATION
6	26891	1	HUB, COULTER 4 BOLT
7	34472	1	COULTER ARM WELDMENT
8	530328	2	IGUS FLANGED BUSHING
9	590123	1	COULTER COMPRESSION SPRING
10	590232	1	MID CASTING
11	590233	1	LOWER CASTING
12	590290	1	BOLT, HH 5/8 X 2 SPECIAL, MAGNI
13	590819M	1	LYNCH PIN, 5/16 X 1-3/4 MAGNI
14	596143M	1	BOLT, HH 7/16 X 2-1/2 GR5 MAGNI
15	596179M	1	BUSHING, MACHINED 1' X 14GA MAGNI
16	596238M	1	NUT, CENTERLOCK 7/16-14 MAGNI
17	596240M	1	NUT, CENTERLOCK, 5/8-11 MAGNI
18	596261M	1	WASHER, FLAT 5/8 MAGNI
19	596626M	1	NUT, TOPLOCK 3/4-10 GR5 MAGNI
20	596740M	1	ROLL PIN, 7/16 X 2 MAGNI
21	596744M	1	BUSHING, MACHINE, 1-1/4 X 14 GA MAGNI
22	750086	1	UPPER DUST CAP WASHER
23	750094	2	COULTER PIVOT BUSHING

N669 Complete Hub with Square Hole with Triple Seal Assembly

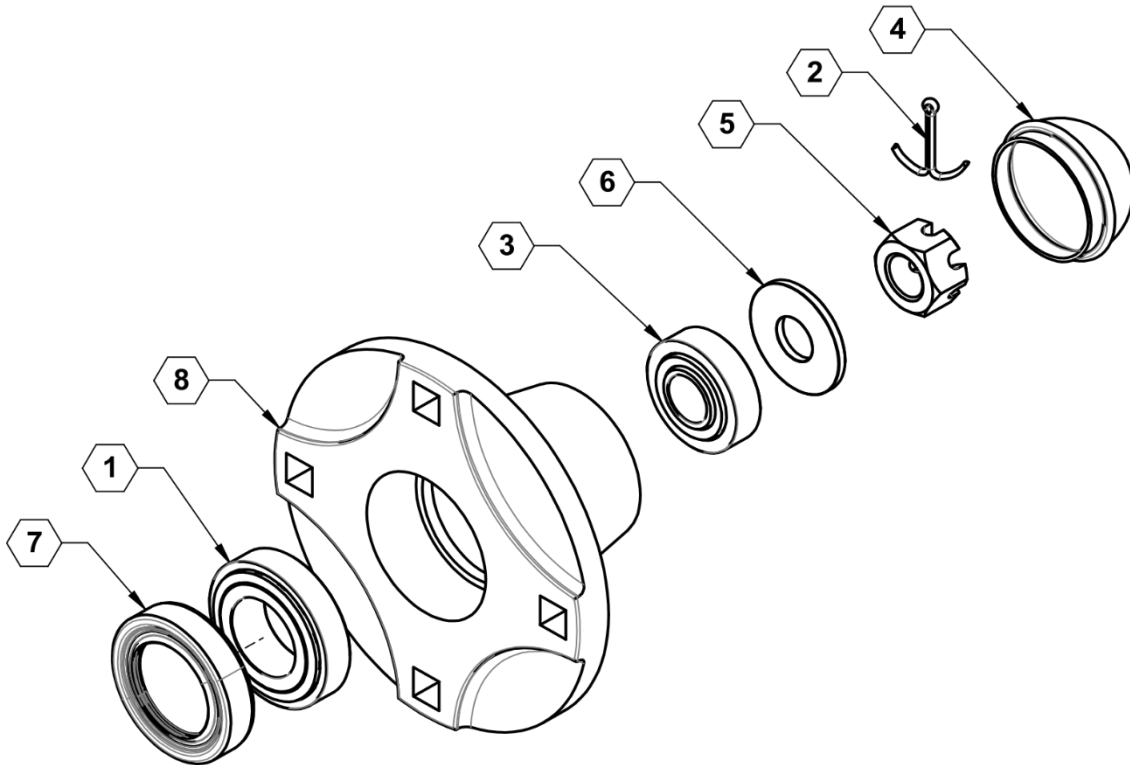

Parts List 26891 / 730095ASSY: N669 Complete Hub with Square Hole with Triple Seal

ITEM	FAST PART NO.	VENDOR PART NO.	QTY.	DESCRIPTION
1	730032		1	BEARING AND RACE, LG LM67048,
1		LM67048	1	BEARING
1		LM67010	1	RACE
2	730033		1	COTTER PIN, N669, 4-BOLT
3	730036		1	BEARING AND RACE, SM LM11949,
3		LM11949	1	BEARING
3		LM11910	1	RACE
4	730044		1	HUB CAP, (699/736) HUB
5	730088		1	CASTLE NUT 4-BOLT, 5/8-18
6	730096		1	WASHER, NSS9 4-BOLT
7	730102		1	SEAL, TRIPLE LIP ID
8	730104		1	HUB, W/ CUPS, 4 BOLT, N669

AP Coultter Upper Casting Mounts

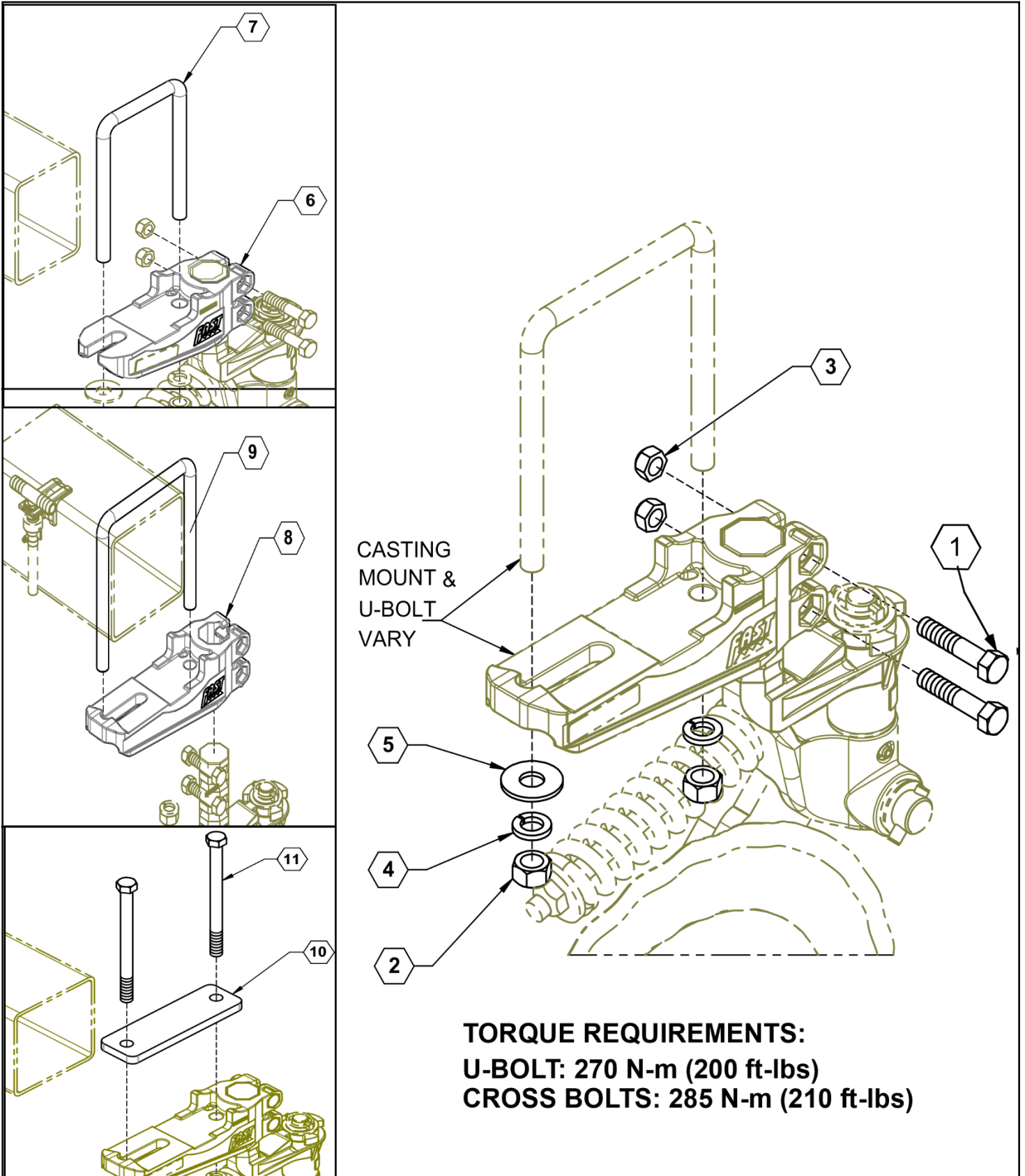

Parts List: AP Coultter Upper Casting Mounts

ITEM	PART NO.	QTY.	DESCRIPTION
1	596779M	2	BOLT, G8 HEX 5/8 X 3 MAGNI
2	596217M	2	NUT, HEX 3/4-10 MAGNI
3	596243M	2	NUT, G8 TOPLOCK 5/8-11 MAGNI
4	596254M	2	LOCKWASHER 3/4 MAGNI
5	596259M	1	WASHER, FLAT 3/4 MAGNI
6	590310	1	MOUNT CASTING AP COULTER
7	596773M	1	U-BOLT, 7 X 5 MAGNI
	596772M	1	U-BOLT, 6 X 4 MAGNI
8	590231	1	MOUNT CASTING, 7X7 TB
9	596774M	1	U-BOLT, 7 X 7 MAGNI
10	17284	1	PLATE, TOP
11	596197M	2	BOLT, 3/4-10 X 9-1/2 MAGNI

AP Coulter Injection Option Assembly

No closing wheel

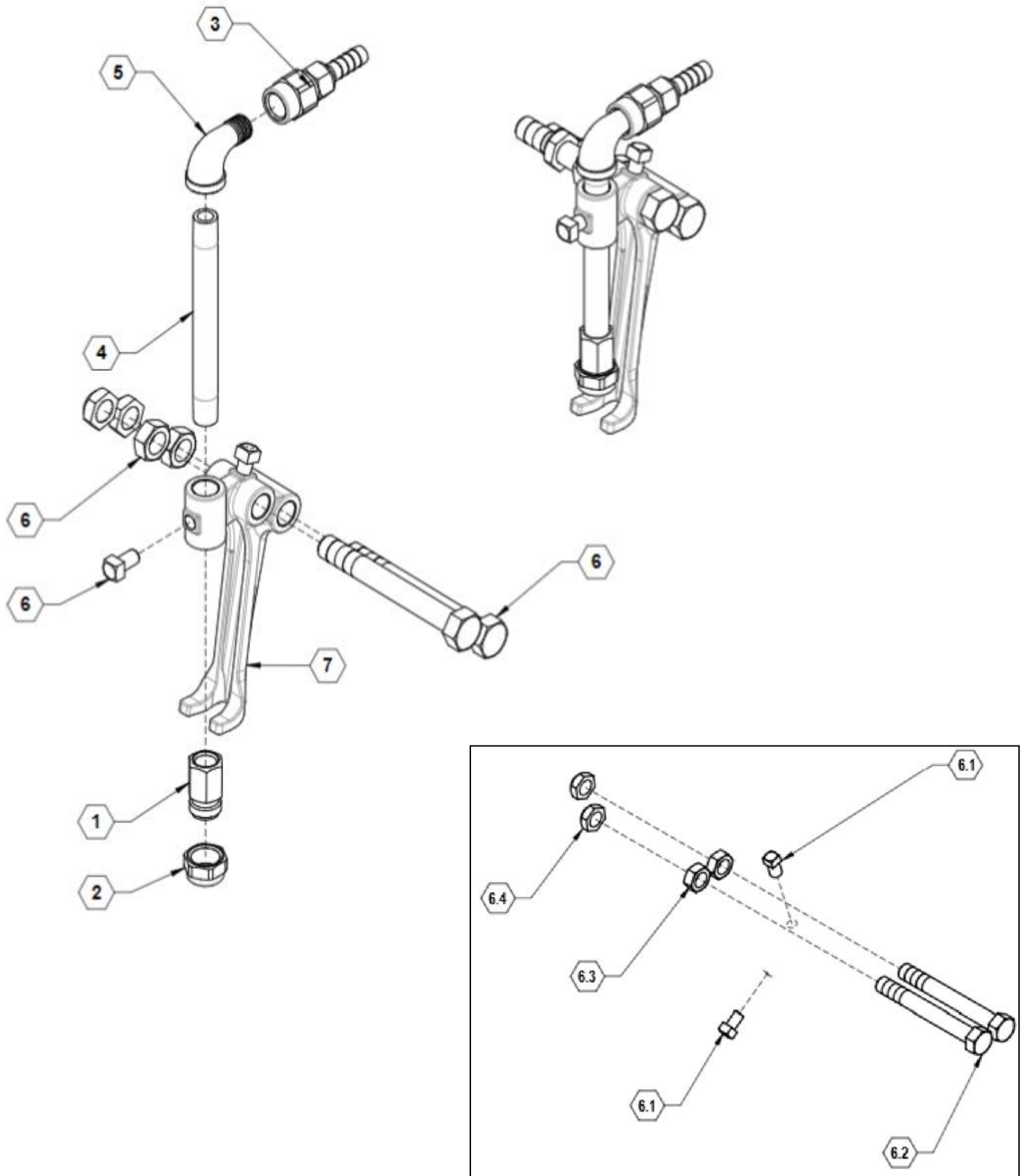

Parts List 90SAINJ: AP Coulter Injection Option Assembly

ITEM	PART NO.	QTY.	DESCRIPTION
1	520014	1	NOZZLE BODY, 1/4" SS
2	520015	1	NOZZLE CAP, SS
3	530188	1	CHECK VALVE ASSEMBLY
4	530199	1	PIPE NIPPLE, 1.4" SS
5	530246	1	ELBOW, 90° STREET 1/4 NPT SS
6	590818	1	HDWE KIT, INJECTION ASSY
6.1	596100M	2	SET SCREW, 3/8-16 X 1/2 MAGNI
6.2	596158M	2	BOLT, HH 1/2 X 4 GR5 MAGNI
6.3	596223M	2	NUT, HEX JAM 1/2 -13 MAGNI
6.4	596618M	2	NUT, TOPLOCK THIN 1/2-13 MAGNI
7	750089	1	CASTING, INJECTION ROCK GUARD

AP Coulter Blade Hardware Kit

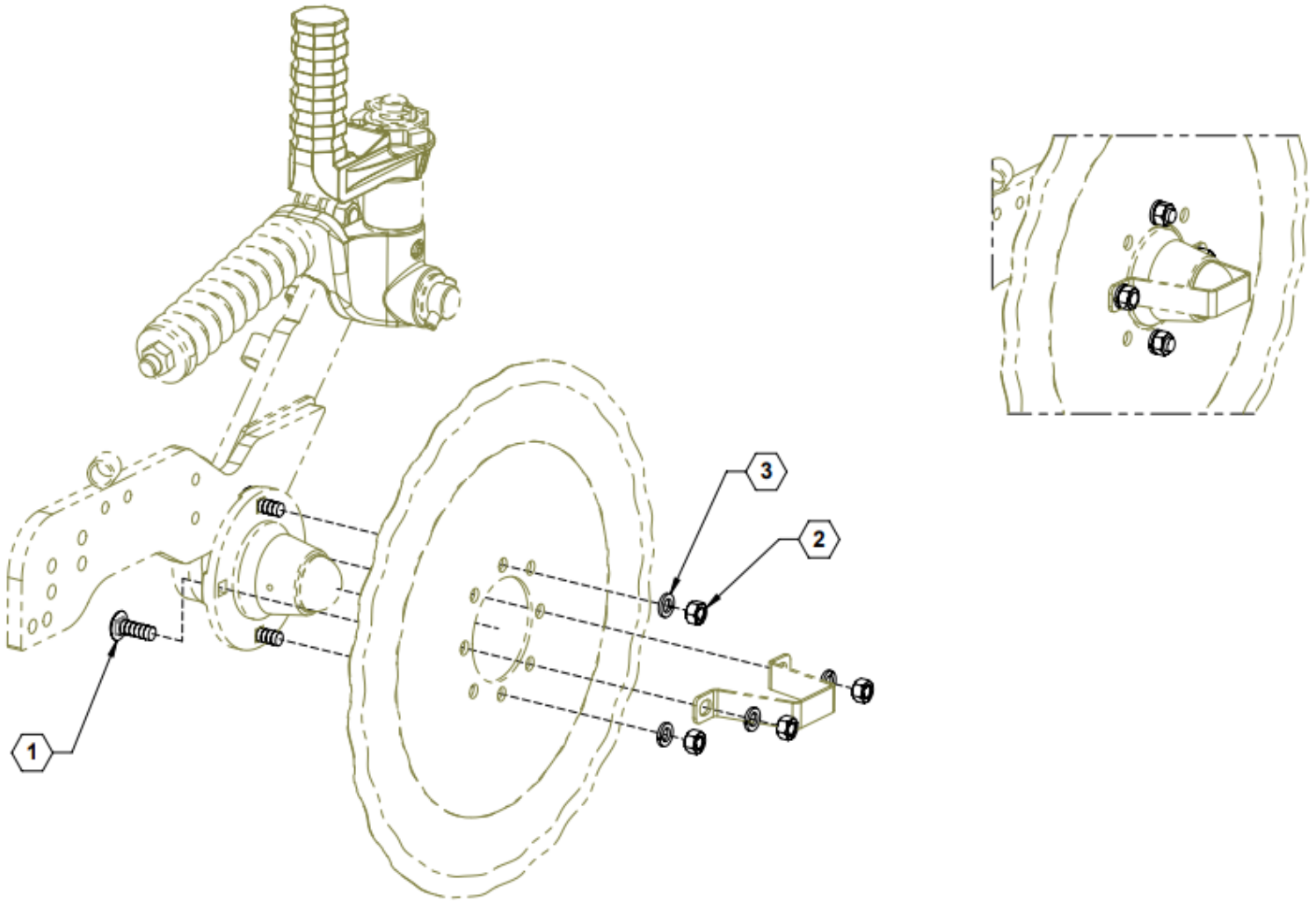

Parts List 590278: AP Coulter Blade Hardware Kit

ITEM	PART NO.	QTY.	DESCRIPTION
1	596620M	4	BOLT, CARR, 1/2 X 1-1/2 GR5 MAGNI
2	596215M	4	NUT, HEX 1/2 NC GR5 MAGNI
3	596251M	4	WASHER, LOCK, 1/2 MAGNI

DEFENDER® for Injection Assembly

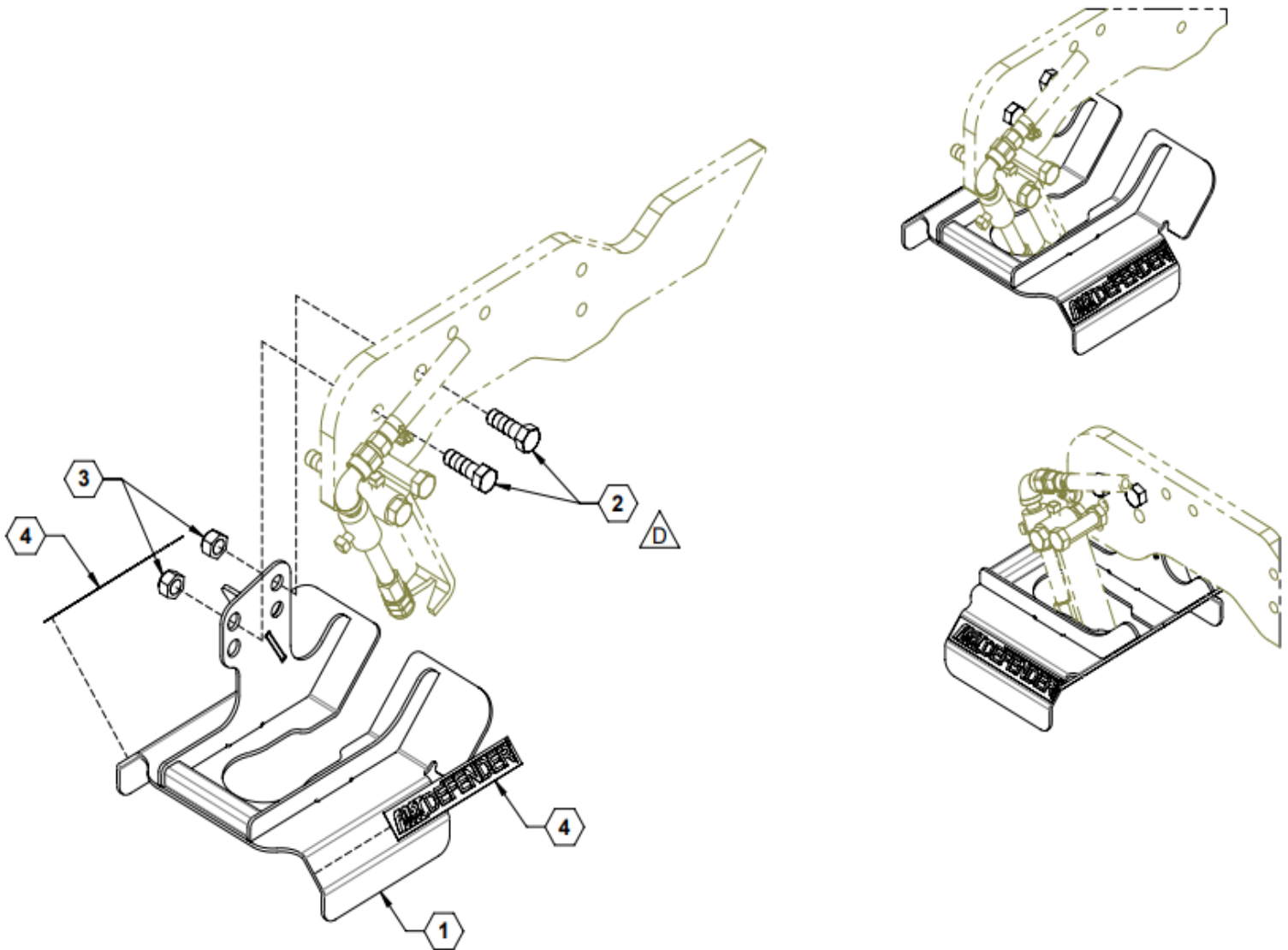

Parts List 17302 / 99CROPDEFENDER: DEFENDER® for Injection

ITEM	PART NO.	QTY.	DESCRIPTION
1	21805	1	COULTER FENDER
2	596153M	2	BOLT, HH 1/2-13X1-1/2 GR5 MAGNI
3	596619M	2	NUT, TOPLOCK 1/2-13 MAGNI
4	800273	2	DECAL, FAST DEFENDER®

AP Coulter Knife High Flow Knife Option

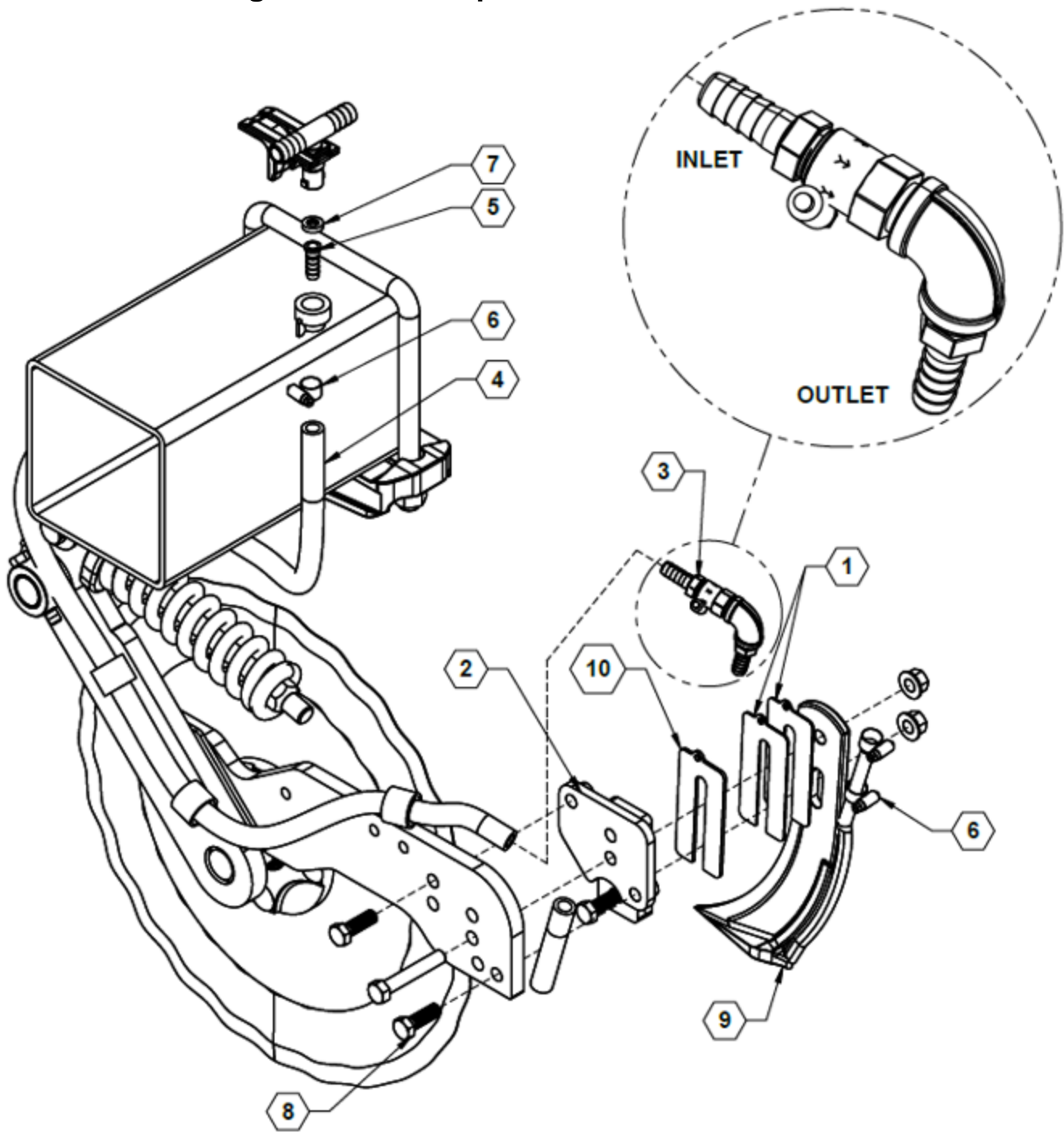

Parts List 37139: AP Coulter Knife High Flow Knife Option

ITEM	PART NO.	QTY.	DESCRIPTION
1	34474	2	KNIFE SHIM, 14 GA
2	34475	1	(PRE 2025) WELDMENT, KNIFE MOUNT
	790121	1	CASTING, KNIFE MOUNT
3	37138	1	HIGH FLOW CHECK ASS, KNIFE
4	510012	5 ft	HOSE, 1/2" EPDM
5	530526	1	CONNECTOR, HOSE BARB
6	540011	4	CLAMP, 3/8" #6H
7	590029	1	SEAL, EPDM
8	590799	1	HARDWARE KIT, KNIFE
9	750100	1	KNIFE, FERTILIZER 1/2"PIPE
10	34551	1	KNIFE SHIM, 11 GA

AP Coulter Knife Option Assembly–Non-Adjustable (2022 and newer, backwards compatible)

NOTES:

1. AFTER KNIFE IS PROPERLY ADJUSTED, SPIN BLADE TO ENSURE THE KNIFE MISSES THE BLADE; ADJUST AS NECESSARY

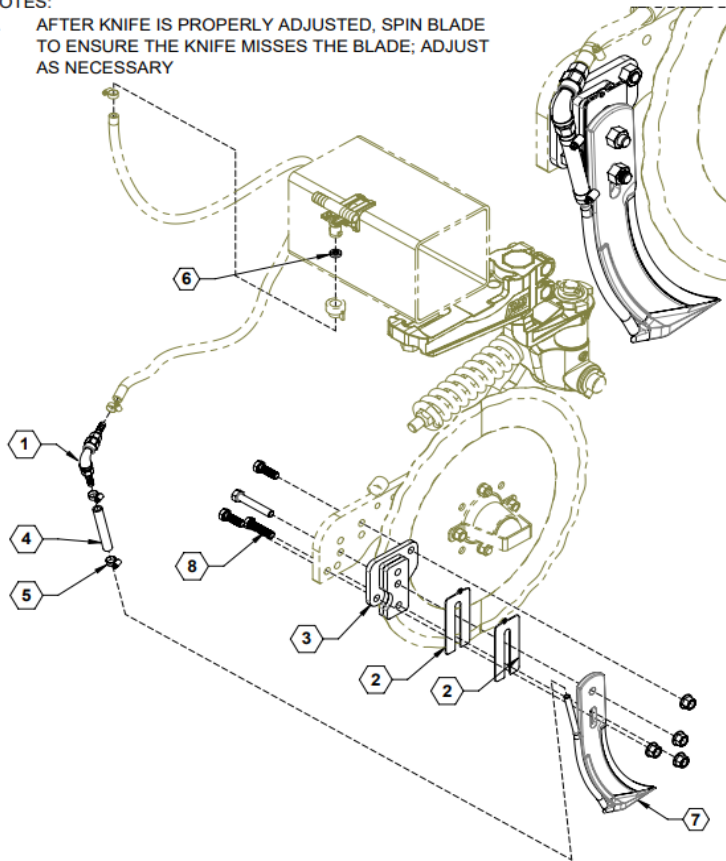

ASSEMBLED VIEW



(1.13)
FACE OF
COULTER ARM
TO FACE OF
KNIFE

KNIFE CENTERED
ON COULTER BLADE
+/- 0.06 INCHES

.26
GAP BETWEEN KNIFE
TIP AND BLADE OD
- SEE NOTE 1 -

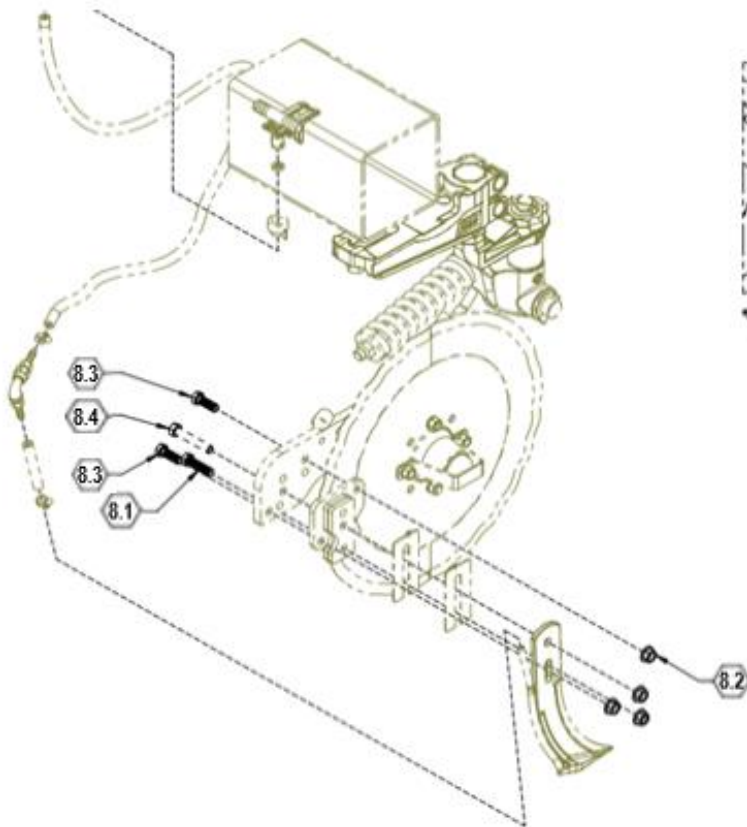
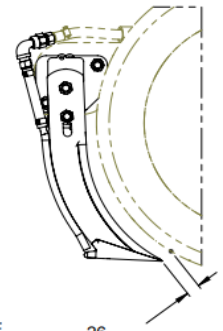

Parts List 34590: AP Coultter Knife Option Assembly–Non-Adjustable (2022 and newer, backwards compatible)

ITEM	PART NO.	QTY.	DESCRIPTION
1	90SACLYKNFCHCKVLV	1	KNIFE CHECK VALVE ASSEMBLY
2	34474	2	KNIFE SHIM, 14 GA
	34551	1	KNIFE SHIM, 11 GA
3	34475	1	(PRE 2025) WELDMENT, KNIFE MOUNT
	790121	1	CASTING, KNIFE MOUNT
4	510020	1	HOSE, 3/8" EPDM X .33FT
5	540032	2	CLAMP, HOSE SS 5/16" #5
6	590029	2	SEAL, EPDM
7	750003	1	KNIFE, EXTRA THIN W/ 3/8" PIPE
8	590799	1	HARDWARE KIT, KNIFE
8.1	596154M	1	BOLT, HH 1/2-13 X 2 GR5 MAGNI
8.2	596820M	4	NUT, FLANGED LOCKNUT, 1/2-13 G8 MAGNI
8.3	596853M	2	BOLT, 1/2"-13 X 1.5 GR. 8 MAGNI
8.4	596854M	1	BOLT, 1/2"-13 X 3" GR. 8 MAGNI

AP Coulter Knife Stop Hardware Kit – Adjustable (2022 and older)

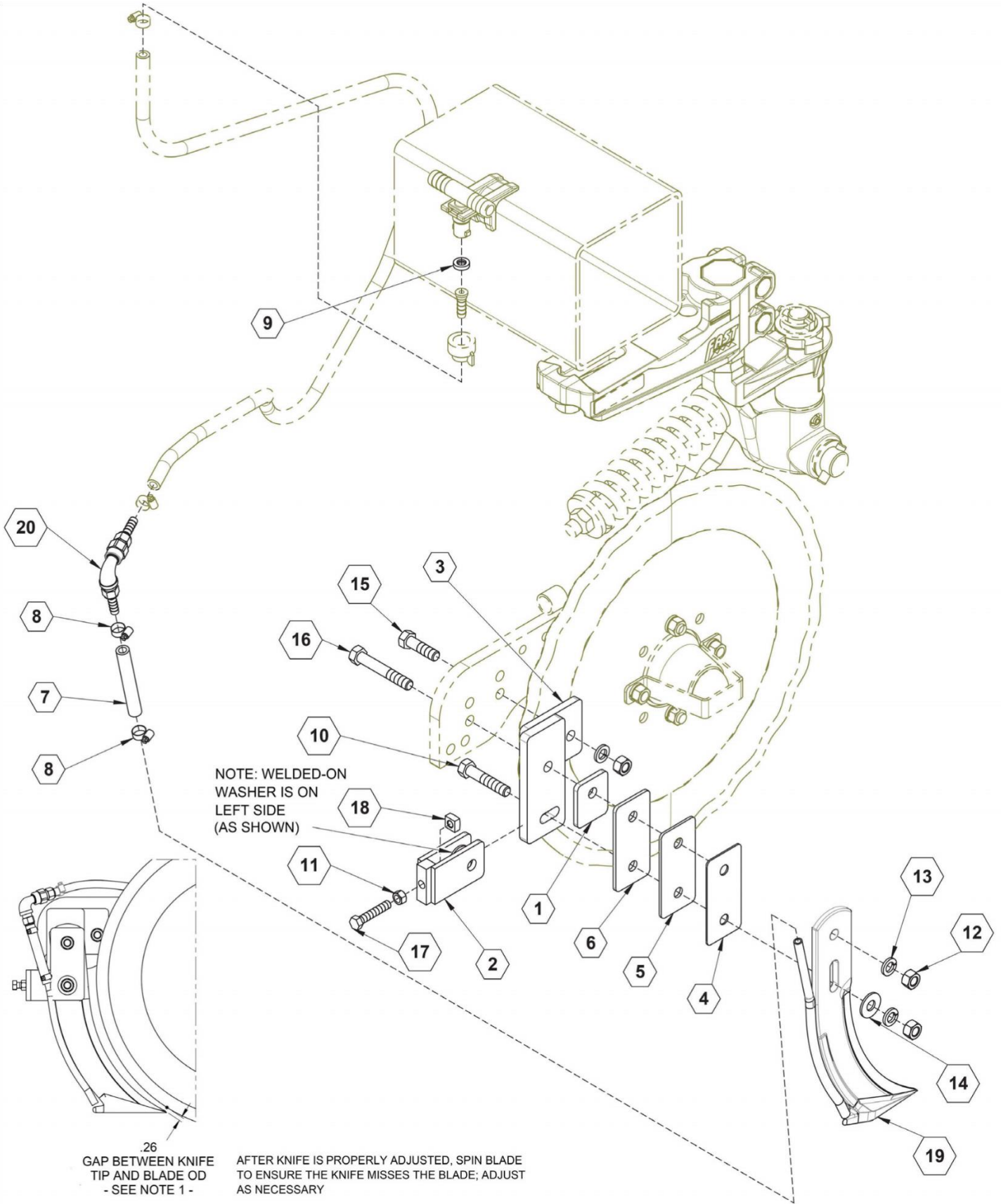

Parts List 99FCAPPKNIFE: AP Coulter Knife Stop Hardware Kit – Adjustable (2022 and older)

ITEM	PART NO.	QTY.	DESCRIPTION
1	17909	1	PLATE, SHIM SPACER
2	17910	1	KNIFE ADJUSTER BRACKET
3	17915	1	KNIFE MOUNT
4	17920	1	KNIFE SHIM, 14 GA
5	17921	1	KNIFE SHIM, 10 GA
6	17922	1	KNIFE SHIM, 7 GA
7	510020	1	HOSE, 3/8", EPDM
8	540032	2	CLAMP, HOSE SS 5/16" #5
9	590029	1	SEAL, EPDM
10	596155M	1	BOLT, HH 1/2-13 X 2-1/2 GR5 MAGNI
11	596213M	1	NUT, HEX 3/8-16 MAGNI
12	596215M	3	NUT, HEX 1/2 NC GR5 MAGNI
13	596251M	3	WASHER, LOCK, 1/2 MAGNI
14	596260M	1	WASHER, FLAT 1/2 MAGNI
15	596639M	1	BOLT, HH 1/2 X 1-3/4 GR5 MAGNI
16	596640M	1	BOLT, HH 1/2 X 3-1/4 GR5 MAGNI
17	596666M	1	BOLT, HH 3/8-16 X 2 MAGNI
18	596762M	1	NUT, SQ 3/8-16 MAGNI
19	750003	1	KNIFE, EXTRA THIN W/ 3/8" PIPE
20	90SACLYKNFCHCKVLV	1	KNIFE CHECK VALVE ASSEMBLY
NS	CP491663	AR	#63 ORIFICE DISK
NS	CP491665	AR	#65 ORIFICE DISK
NS	CP491672	AR	#72 ORIFICE DISK
NS	CP491675	AR	#75 ORIFICE DISK
NS	CP491677	AR	#77 ORIFICE DISK
NS	CP491678	AR	#78 ORIFICE DISK
NS	CP491680	AR	#80 ORIFICE DISK
NS	CP491689	AR	#89 ORIFICE DISK
NS	CP491691	AR	#91 ORIFICE DISK
NS	CP491693	AR	#93 ORIFICE DISK
NS	CP4916103	AR	#103 ORIFICE DISK
NS	CP4916107	AR	#017 ORIFICE DISK
NS	CP4916115	AR	#115 ORIFICE DISK
NS	CP4916125	AR	#125 ORIFICE DISK
NS	CP4916132	AR	#132 ORIFICE DISK
NS	CP4916144	AR	#144 ORIFICE DISK
NS	CP4916151	AR	#151 ORIFICE DISK
NS	CP4916177	AR	#177 ORIFICE DISK

Decal Assembly

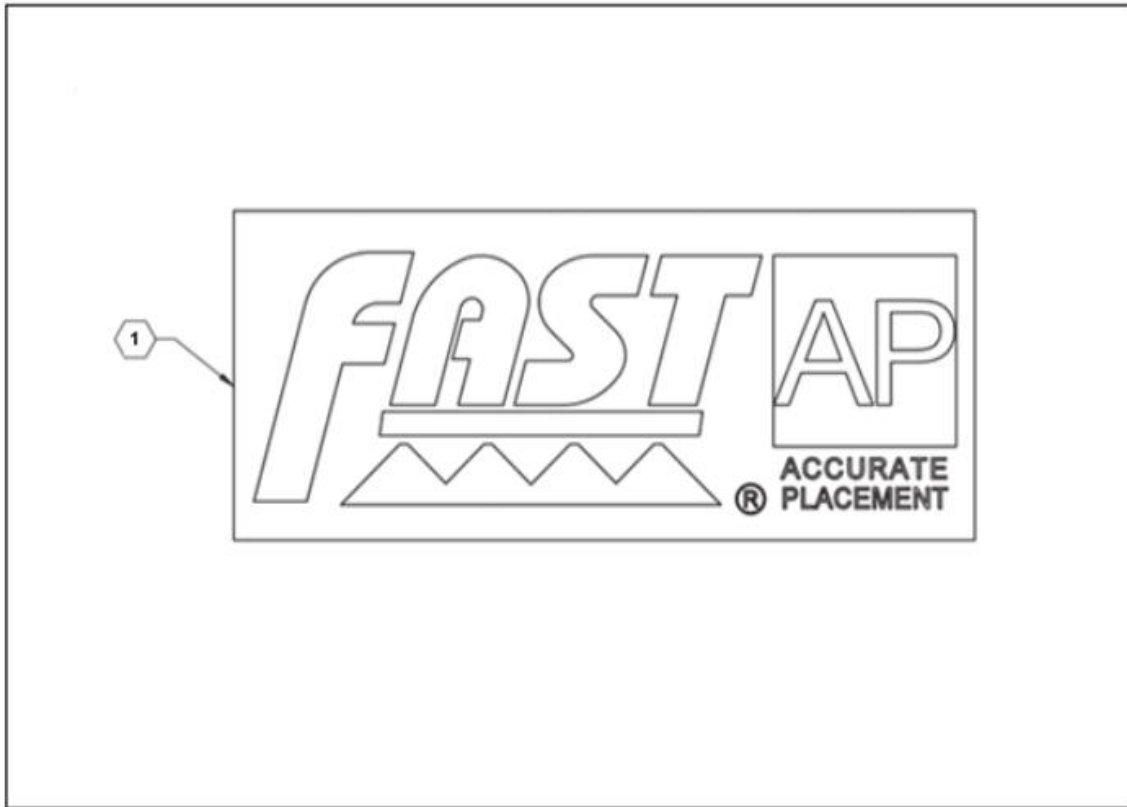

Parts List 17292: Decal Assembly

ITEM	PART NO.	QTY.	DESCRIPTION
1	800210	1	DECAL, FAST AP COULTER LOGO

SMV and SIS

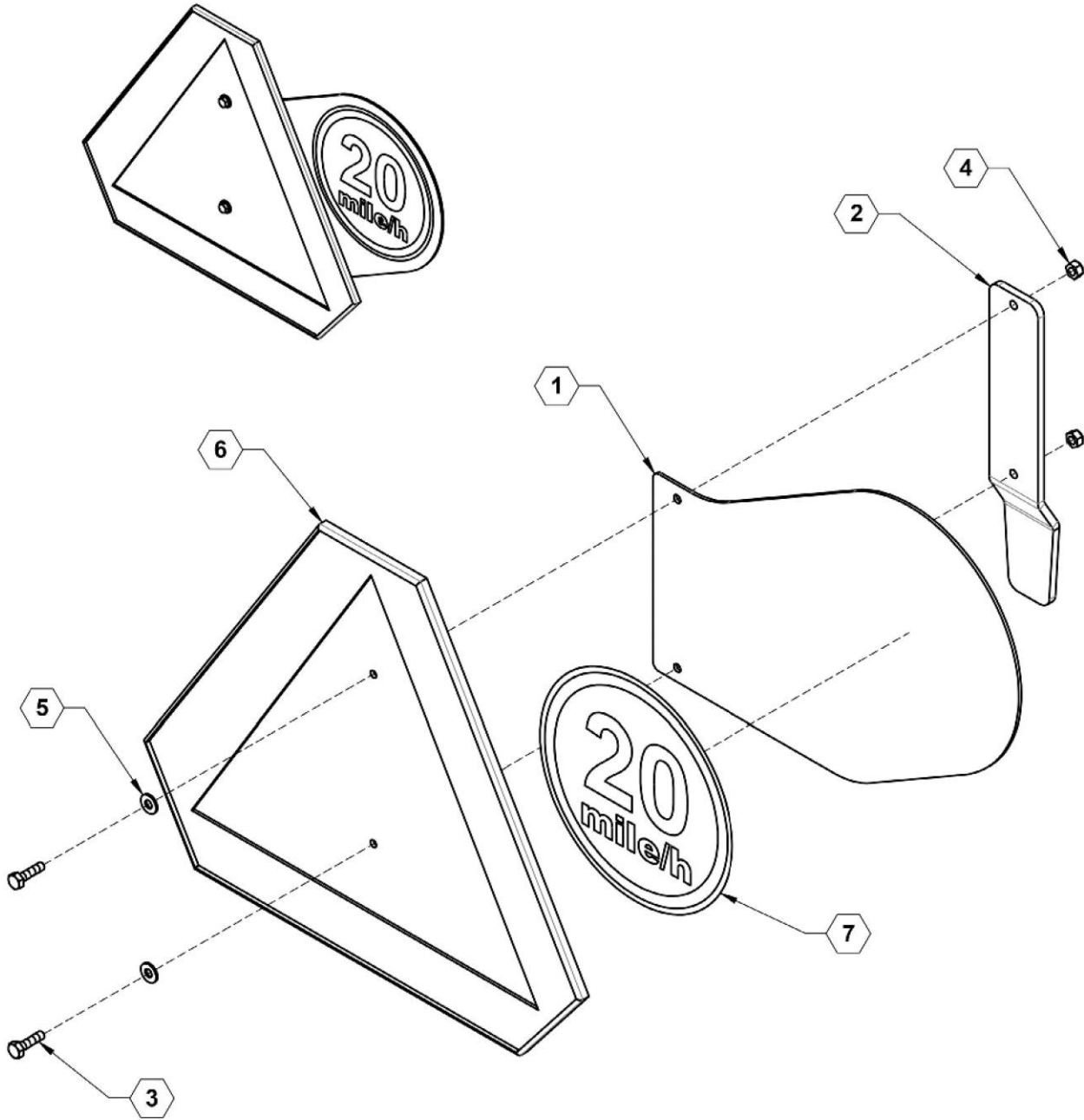

Parts List 90SASMV: SMV and SIS

ITEM	PART NO.	QTY.	DESCRIPTION
1	28251	1	PLATE, SIS MOUNT
2	28252	1	PLATE, SMV MOUNT
3	593102M	2	BOLT, HH 1/4-20 X 1 GR5 MAGNI
4	596227M	2	NUT, HEX NYLOCK 1/4-20 MAGNI
5	596256M	2	WASHER, FLAT 1/4 USS MAGNI
6	790017	1	SIGN, SMV PLASTIC MOLDED
7	800306	1	DECAL, SIS, 20 mile/h
7	800307	1	DECAL, SIS, 30 km/h

Ace 150-206 Pump Hydraulic Motor

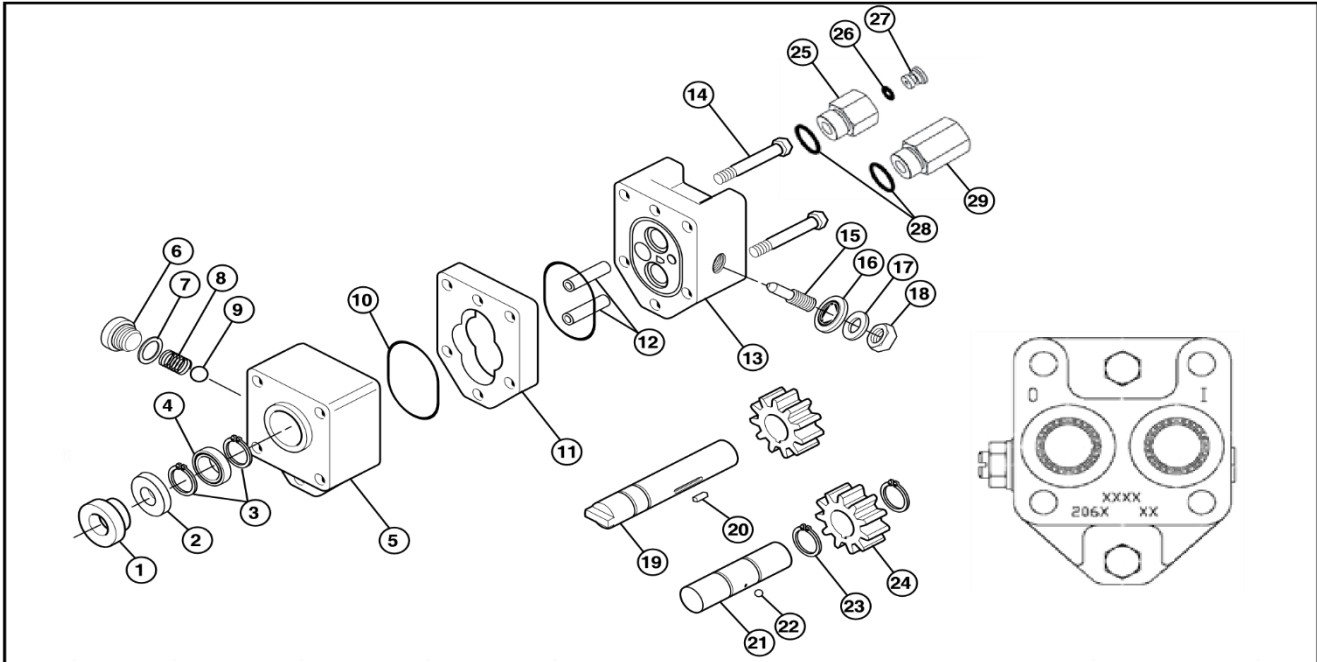

Parts List 550000: Ace 150-206 Pump Hydraulic Motor

ITEM	MODEL 204N	206N	210N	DESCRIPTION	QTY.
1*	S200	S200	S200	SEAL SUPPORT SPACER	1
2*	40153	40153	40153	SEAL CARTRIDGE	1
3	41941	41941	41941	SNAP RING, BEARING	2
4	41961	41961	41961	BALL BEARING, 7/16" I.D.	1
5	41731	41731	41731	DRIVE PLATE	1
6	42041	42041	42041	VALVE CAP, COASTING CHECK	1
7*	42044	42044	42044	"O" RING, COASTING CHECK	1
8	42042	42042	42042	SPRING, COASTING CHECK	1
9	42043	42043	42043	BALL, COASTING CHECK	1
10*	41850	41850	41850	"O" RING, HOUSING SEAL	2
11	41720	41721	41725	GEAR HOUSING	1
12	41800	41801	41805	DOWEL PIN, HOUSING	2
13	41742	41742	41742	END PLATE	1
14	41900	41900	41905	CAP SCREW, 1/4" N.C. HEX HEAD	2
15	42010	42010	42010	ADJUSTING SCREW, NEEDLE VALVE	1
16*	42030	42030	42030	THREAD SEAL, 3/8", NEEDLE VALVE	1
17	42040	42040	42040	WASHER, FLAT STEEL, NEEDLE VALVE	1
18	40960	40960	40960	NUT, 3/8" N.C. JAM, NEEDLE VALVE	1
19	41761	41764	41766	DRIVE SHAFT	1
20	41920	41921	41925	DOWEL PIN, DRIVE SHAFT	1
21	41970	41971	41975	IDLER SHAFT	1
22	41990	41990	41990	BALL, IDLER SHAFT	1
23	41980	41980	41980	RETAINING RING, IDLER GEAR	2
24	41750	41751	41755	GEAR	2
25	41455	41455	41455	ADAPTER BODY, #8 SAE MALE X 1/2" NPT	1
26	41448	41448	41448	"O" RING, ORIFICE INSERT (USE WITH 41456 INSERT)	1
27	41457	41456	41456	INSERT, RESTRICTOR ORIFICE (USE WITH 41455 BODY)	1
28	41875	41875	41875	"O" RING, #8 SAE MALE FITTING	2
29	41441	41441	41441	REVERSE CHECK, #8 SAE MALE X 1/2" NPT	1
#	41374	41374	41374	REPAIR KIT, RK-BAC-75-HYD-L	--

Ace 150-206 Pump

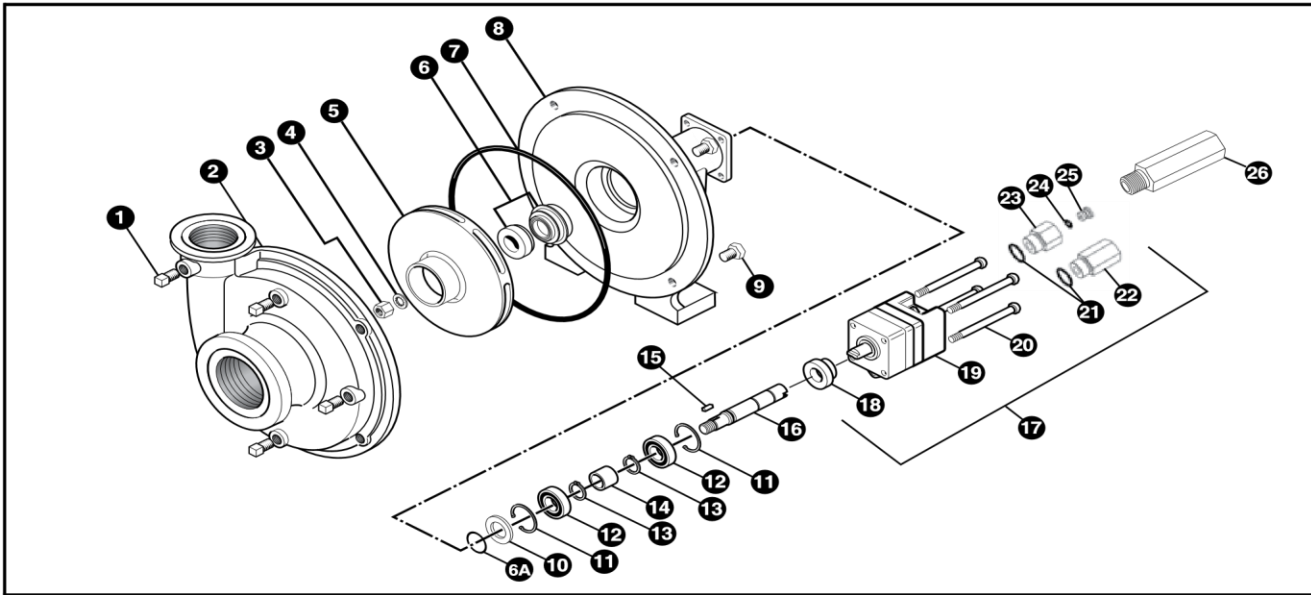

Parts List 550000: Ace 150-206 Pump

ITEM	PART NO.	EDP NO.	DESCRIPTION	QTY.
1	BAC-53	41110	PIPE PLUG	4
1	41120	41120	PIPE PLUG, STAINLESS STEEL (OPTIONAL)	4
2	BAC-12-150-FLG	40257	VOLUTE, CAST IRON, NPT & ?ANGED (FOR 150F MODELS)	1
2	BAC-12-150-SS	40249	VOLUTE, 316 STAINLESS STEEL , NPT & ?ANGED (FOR 150FS MODELS)	1
3	BAC-23-A	40391	NUT, 3/8" NF, CAD PLATED	1
3	BAC-23-A-SS	40392	NUT, 3/8" NF, STAINLESS STEEL (OPTIONAL)	1
4 (*) (**)	BAC-24-HYD-SS	40400	WASHER, 3/8" STAR, STAINLESS STEEL	1
5	BAC-26-150-P	40446	IMPELLER, VALOX, KEYWAY	1
5	BAC-26-150-CI	40445	IMPELLER, CAST IRON, KEYWAY (OPTIONAL)	1
6 (*)	BAC-7V	40151	SEAL, CARBON/CERAMIC/VITON (INCLUDES 40160 O-RING)	1
6 (**)	BAC-7SC	40152	SEAL, SILICON CARBIDE/VITON (INCLUDES 40160 O-RING) (OPTIONAL)	1
6A (*) (**)	40160	40160	O-RING, SHAFT SEAL	1
7 (*) (**)	BAC-4-150	40015	O-RING, BODY SEAL	1
8	BAC-14-150-HYD	40305	MOUNTING FRAME, CAST IRON (FOR 150F MODELS)	1
8	BAC-14-150-HYD-SS	40319	MOUNTING FRAME, 316 STAINLESS STEEL (FOR 150FS MODELS)	1
9	40950	40950	CAP SCREW, 3/8" NC X 3/4" HEX HEAD	4
9	40930	40930	CAP SCREW, 3/8" NC X 3/4" HEX HEAD, STAINLESS STEEL (OPTIONAL)	4
10	BAC-54	41130	SLINGER	1
11	BAC-33	40810	SNAP RING, INTERNAL, BAC-14 MOUNTING FRAME	2
12	BAC-37	40870	BALL BEARING, SEALED, BAC-6 SHAFT	2
13	BAC-32	40790	SNAP RING, EXTERNAL, BAC-6 SHAFT	2
14	BAC-32-S	40795	SPACER FOR BAC-6 SHAFT	1
15	BACH-25	40420	KEY, 1/8" X 1/8" X 1/2"	1
16	BAC-6-HYD-SS	40061	SHAFT, 5/8" DIAMETER, KEYWAY AND TANG SLOT, STAINLESS STEEL	1
17	BAC-75-HYD-206	41372	HYDRAULIC MOTOR, 7 GPM (INCLUDES PARTS 18 - 25)	1
18	S200	40161	SEAL SUPPORT SPACER FOR 200 SERIES HYD MOTOR	1
19	BAC-75-HYD-206N	41397	HYDRAULIC MOTOR, 7 GPM (MOTOR ONLY - NO EXTERNAL ?TTINGS)	1
20	41255	41255	CAP SCREW, 5/16" N. C. X 3-3/4" SOCKET HEAD (FOR 206N MOTOR)	4
21	41875	41875	"O" RING, #8 SAE MALE FITTING	2
22	BAC-78-8SAE	41441	REVERSE CHECK, #8 SAE MALE X 1/2" NPT	1
23	BAC-80-8SAE	41455	ADAPTER BODY, #8 SAE MALE X 1/2" NPT	1
24	41448	41448	"O" RING, ORIFICE INSERT (USE WITH 41456 INSERT)	1
25	BAC-79-7	41456	INSERT, RESTRICTOR ORIFICE (USE WITH 41455 BODY)	1
26	LS-206N	41418	FLOW LIMITING VALVE (206N), #8 SAE MALE X 1/2" NPT FEMALE	1
*	RK-FMC-150	52710	REPAIR KIT FOR FMC-150 SERIES PUMP	-
**	RK-FMCSC-150	52711	REPAIR KIT FOR FMC-150 SERIES WITH SILICON CARBIDE SHAFT SEAL	-
#	RK-BAC-75-HYD-L	41374	REPAIR KIT, RK-BAC-75-HYD-L	-

Ace 304 Pump

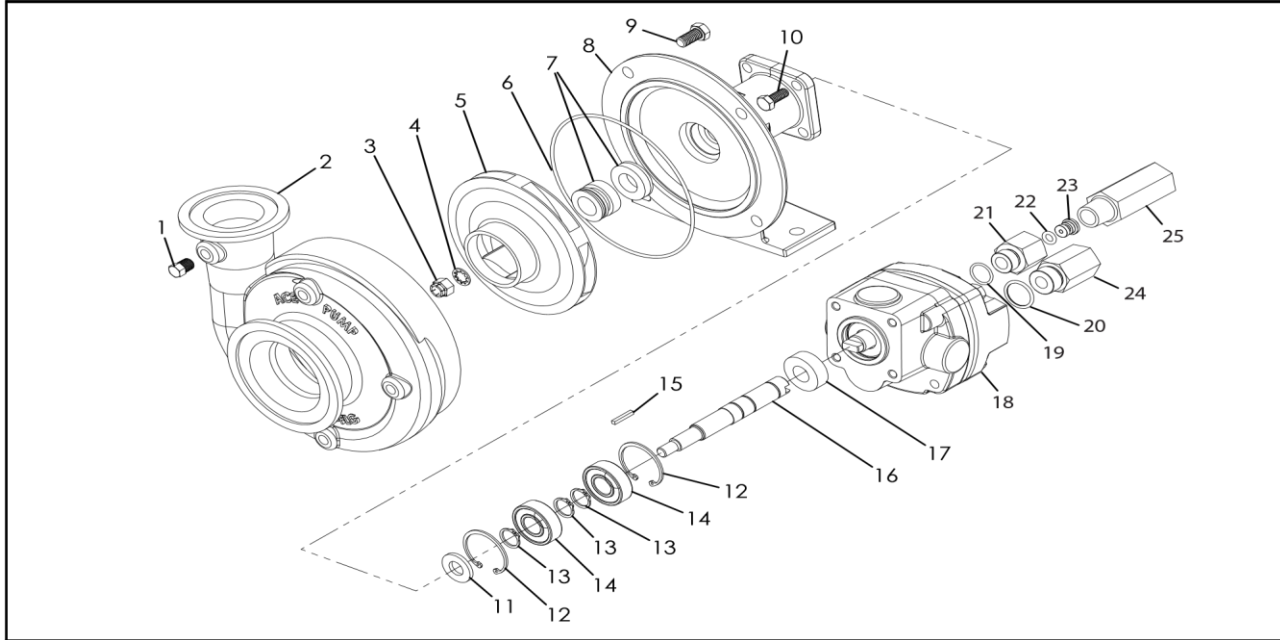

Parts List 550035: Ace 304 Pump

ITEM	PART NO.		QTY.	DESCRIPTION
	Model 304N	Model 310N		
1	40162	40162	1	SEAL SUPPORT SPACER, S300 FOR 200 SERIES PUMPS
1	40163	40163	1	SEAL SUPPORT SPACER, S305 FOR 205 SERIES PUMPS
2*	40154	40154	1	SEAL CARTRIDGE, BAC-75-300-TLS
3	43056	43056	1	SPACER SEAL/BEARING, PERFORATED, 300 SERIES MOTOR
4	43205	43205	2	RETAINING RING, BEARING
5	43225	43225	1	BALL BEARING
6	43016	43016	1	DRIVE PLATE
7*	43130	43130	2	O-RING, HOUSING SEAL
8	43085	43080	2	DOWEL PIN, HOUSING
9	43005	43000	1	GEAR HOUSING
10	43277	43277	1	CAP, NEEDLE VALVE WITH O-RING, 300N SERIES MOTOR
11*	43276	43276	1	O-RING, NEEDLE VALVE CAP
12	43266	43266	1	NEEDLE, 300N SERIES MOTOR
13	43022	43022	1	END PLATE, 300N SERIES MOTOR
14	43185	43180	4	CAP SCREW, 3/8" N.C. HEX HEAD
15	43240	43240	2	RETAINING RING, GEAR
16	43035	43030	2	GEAR
17	43250	43250	1	BALL, IDLER SHAFT
18	43235	43230	1	IDLER SHAFT
19	43046	43039	1	DRIVE SHAFT
20	43195	43190	1	DOWEL PIN, DRIVE SHAFT
21	41455	41455	1	ADAPTER BODY, #8 SAE MALE X 1/2" NPT
22	41448		1	"O" RING, ORIFICE INSERT (USE WITH 41456 INSERT)
23	41447		1	ORIFICE INSERT, RESTRICTOR INSERT
24	41875	41875	1	"O" RING, #8 SAE MALE FITTING
25	41445	41445	1	O-RING, #10 SAE FITTING
26	41442	41442	1	REVERSE CHECK ASSEMBLY, #10 SAE X 1/2" NPT
*	41362	41362	AR	MOTOR REPAIR KIT, INCLUDES 2, 7, 11

ACE 150-206 Pump, Self Priming

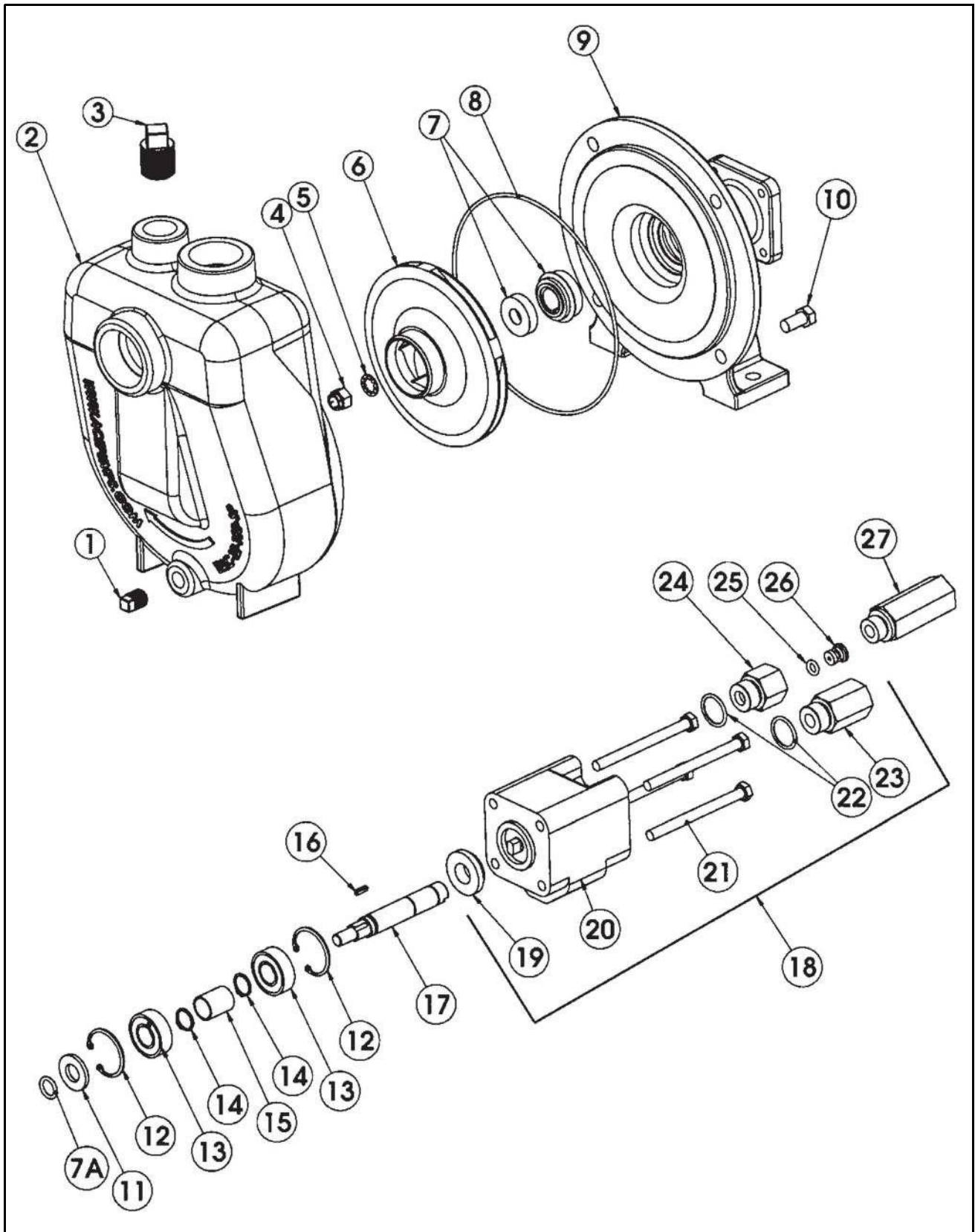

Parts List 550043: ACE 150-206 Pump, Self Priming

ITEM	VENDOR PART NO.	EDP PART NO.	QTY.	DESCRIPTION
1	20750	20750	1	PIPE PLUG, DRAIN, 1/4" NPT
2	BAC-12-150-SP	40254	1	VOLUTE, SEPF-PRIMING, 1-1/2" X 1-1/4"
3	41105	41105	1	PIPE PLUG, FILL, 3/4" NPT
4	BAC-23-A	40391	1	NUT, 3/8" NF, CAD PLATED
4	BAC-23-B-SS	40393	1	NUT, 3/8" NF, STAINLESS STEEL (STANDARD ON -SS MODELS)
5 (*1*2)	BAC-24-HYD-SS	40400	1	WASHER, 3/8" STAR, STAINLES STEEL
5	BAC-24-B-SS	42702	1	WASHER, 3/8", STAINLESS STEEL, VIBRATION PROOF (STANDARD ON -SS MODELS)
6	BAC-26-150-P	40446	1	IMPELLER, VALOX, KEYWAY
6	BAC-26-150-CI	40445	1	IMPELLER, CAST IRON, KEYWAY (OPTIONAL)
6	BAC-26-150-P I	40448	1	IMPELLER, POLYPROPYLENE, KEYWAY (OPTIONAL)
7 (*1)	BAC-7V	40151	1	SEAL, CARBON / CERAMIC / VITON (INCLUDES 40160 O-RING)
7 (*2)	BAC-7SC	40152	1	SEAL, CARBON / CERAMIC / VITON (INCLUDES 40160 O-RING) (OPTIONAL)
7A (*1*2)	40160	40160	1	O-RING, SHAFT SEAL
8 (*1*2)	BAC-4-150	40015	1	O-RING, BODY SEAL
9	BAC-14-150-HYD	40305	1	MOUNTING GRAME (FOR 200 SERIES HYDRAULIC MOTOR)
10	40950	40950	4	CAP, SCREW, 3/8" NC X 3/4" HEX HEAD
10	40930	40930	4	CAP, SCREW, 3/8" NC X 3/4" HEX HEAD, STAINLESS STEEL (OPTIONAL)
11	BAC-54	41130	1	SLINGER
12	BAC-33	40810	2	SNAP RING, INTERNAL, BAC-14 MOUNTING FRAME
13	BAC-37	40870	2	BALL BEARING, SEALED, BAC-6 SHAFT
14	BAC-32	40790	2	SNAP RING, EXTERNAL, BAD-6 SHAFT
15	BAC-32-S	40795	1	SPACER FOR BC-6 SHAFT
16	BACH-25	40420	1	KEY, 1/8" X 1/8" X 1/2"
17	BAC-6-HYD-SS	40061	1	SHAFT, 5/8" DIAMETER, KEYWAY AND TANG SLOT, STAINLESS STEEL
18	BAC-75-HYD-206	41372	1	HYDRAULIC MOTOR, 7 GPM (INCLUDES PARTS 19-26)
19	S200	40161	1	SEAL SUPPORT SPACER FOR 200 SERIES HYD MOTOR
20	BAC-75-HYD-206N	41397	1	HYRAULIC MOTOR, 7 GPM (MOTOR ONLY – NO EXTERNAL FITTINGS)
21	41255	41255	4	CAP SCREW, 5/16" N.C. X 3-3/4" SOCKET HEAD (FOR 206N MOTOR)
22	41875	41875	2	O-RING, #8 SAE FITTING
23	BAC-78-8SAE	41441	1	REVERSE CHECK ASSEMBLY, #8 SAE MALE X 1/2" NPT FEMALE
24	BAC-80-8SAE	41455	1	BODY, RESTRICTOR ORIFICE, #8 SAE MALE X 1/2" NPT FEMALE
25	41448	41448	1	O-RING, ORIFICE INSERT
26	BAC-79-7	41456	1	ORIFICE, RESTRICTOR INSERT, 0.109 (206N)
27	LS-206N	41418	1	FLOW LIMITING VALVE (206N), #8 SAE MALE X 1/2" NPT FEMALE
*1	RK-FMC-150	52710	1	REPAIR KIT FOR FMC-150 SERIES PUMP
*2	RK-FMCS-150	52711	1	REPAIR KIT FOR FMC-150 SERIES WITH SILICON CARBIDE SHAFT SEAL
#	RK-BAC-75-HYD-L	41374	1	REPAIR KIT FOR 200 SERIES MOTOR WITH HIGH PRESSURE LIP SEAL

Hypro Pump

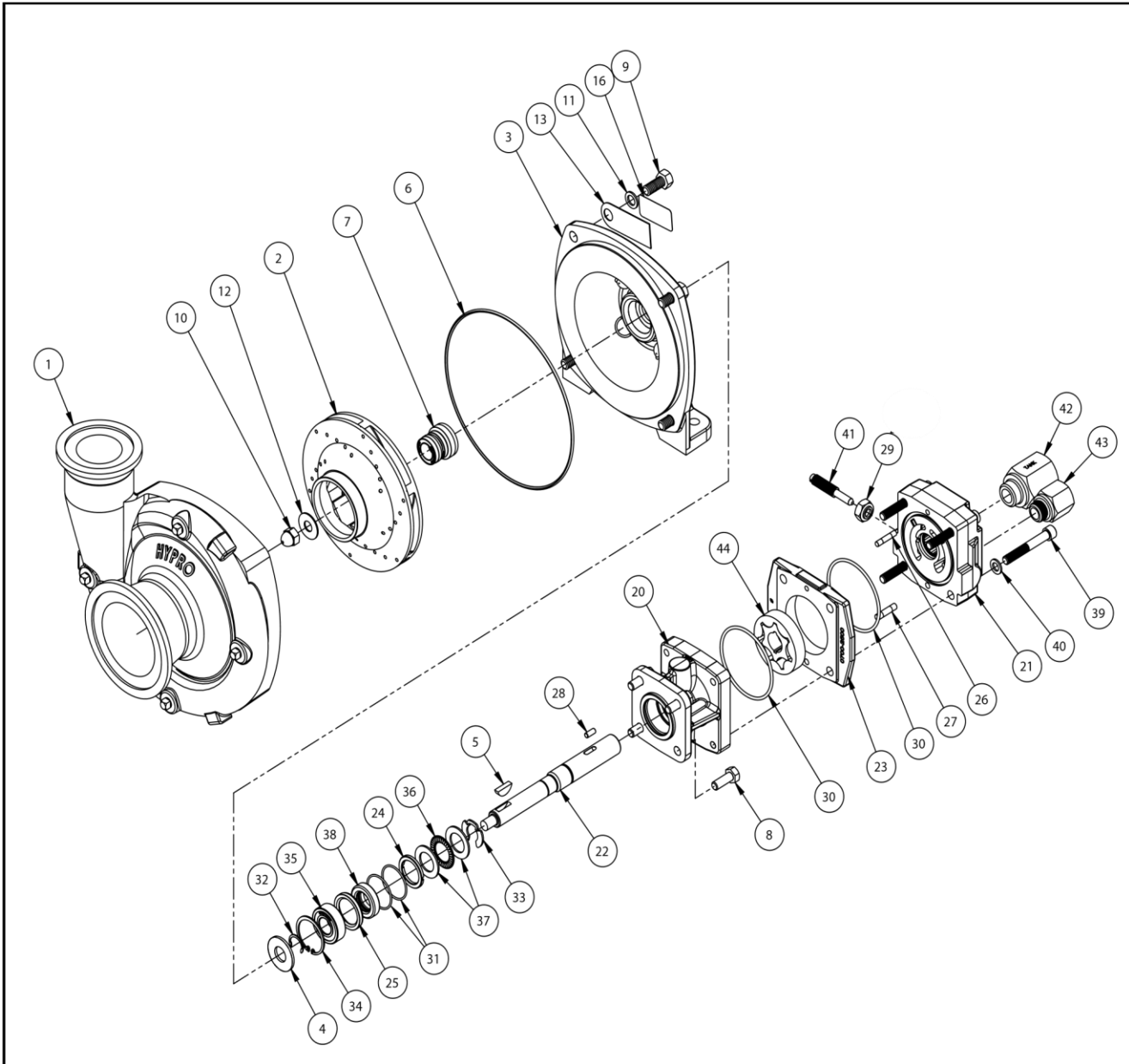

Parts List 550011: Hypro Pump

ITEM	PART NO.	QTY.	DESCRIPTION
1	0158-9200C	1	PUMP HOUSING, 300 X 220 U.FLG
2	0401-9200P 2	1	IMPELLER (CW ROTATION)
3	0750-9300C2	1	MOUNTING FLANGE
4	1410-0056	1	SLINGER SEAL
5	1610-0012	1	WOODRUFF KEY
6	1720-0083	1	O-RING
7	2120-0039	1	SEAL, MECHANICAL
8	2210-0005	4	CAP SCREW, HEX HEAD 5/16"-18 X 7/8"
9	2210-0020	4	CAP SCREW, HEX HEAD 3/8"-16 X 7/8"
10	2253-0002	1	ALCNUT 0.3750-24-N
11	2270-0041	1	WASHER
12	2270-0071	1	IMPELLER WASHER
13	2270-0076	1	TAG
14	3031-0134	1	CARTON – INDIVIDUAL
15	3435-0171	1	PACKING KIT
16	6031-0325	1	DECAL
17	6031-0340	1	LABEL READ FOR ROUND UP
18	6031-0343	1	INSTRUCTION TAG
19	6031-0373	1	CE STICKER LABEL
20	0150-2500C	1	NPDU ASSU – SMALL PILOT
21	0254-2500C2	1	END PLATE ASSY
22	0533-2500	1	SHAFT
23	0700-2500C1	1	GEROTO HOUSING HM1, COATED
24	1410-0130	1	SPACER, 3L SEAL
25	1410-0131	1	CARTRIDGE, FRONT
26	1600-0037	1	DOWEL PIN
27	1600-0044	1	DOWEL PIN
28	1610-0031	1	HM1 & HM5 ROUND KEY
29	1700-0245	1	NUT, SEALING
30	1720-0110	2	O-RING
31	1720-0268	2	O-RING
32	1810-0014	1	RETAINING RING
33	1810-0026	1	RETAINING RING
34	1820-0013	1	INT. RET. RING
35	2000-0010	1	BEARING, BALL
36	2029-0009	1	BEARING, THRUST
37	2029-0010	2	BEARING RACE, THRU
38	2104-0010	1	LIP SEAL
39	2220-0021	4	SCREW, SOCKET HEAD
40	2270-0039	4	WASHER, FLAT 5/16:
41	3220-0029	1	VALVE STEM
42	3320-0052A	1	CHECK VALVE ASSY – TANK PORT
43	3360-0023A	1	ADAPTER – INLET PORT ASSY
44	3900-0022	1	GEROTOR

Ball Valve Mount

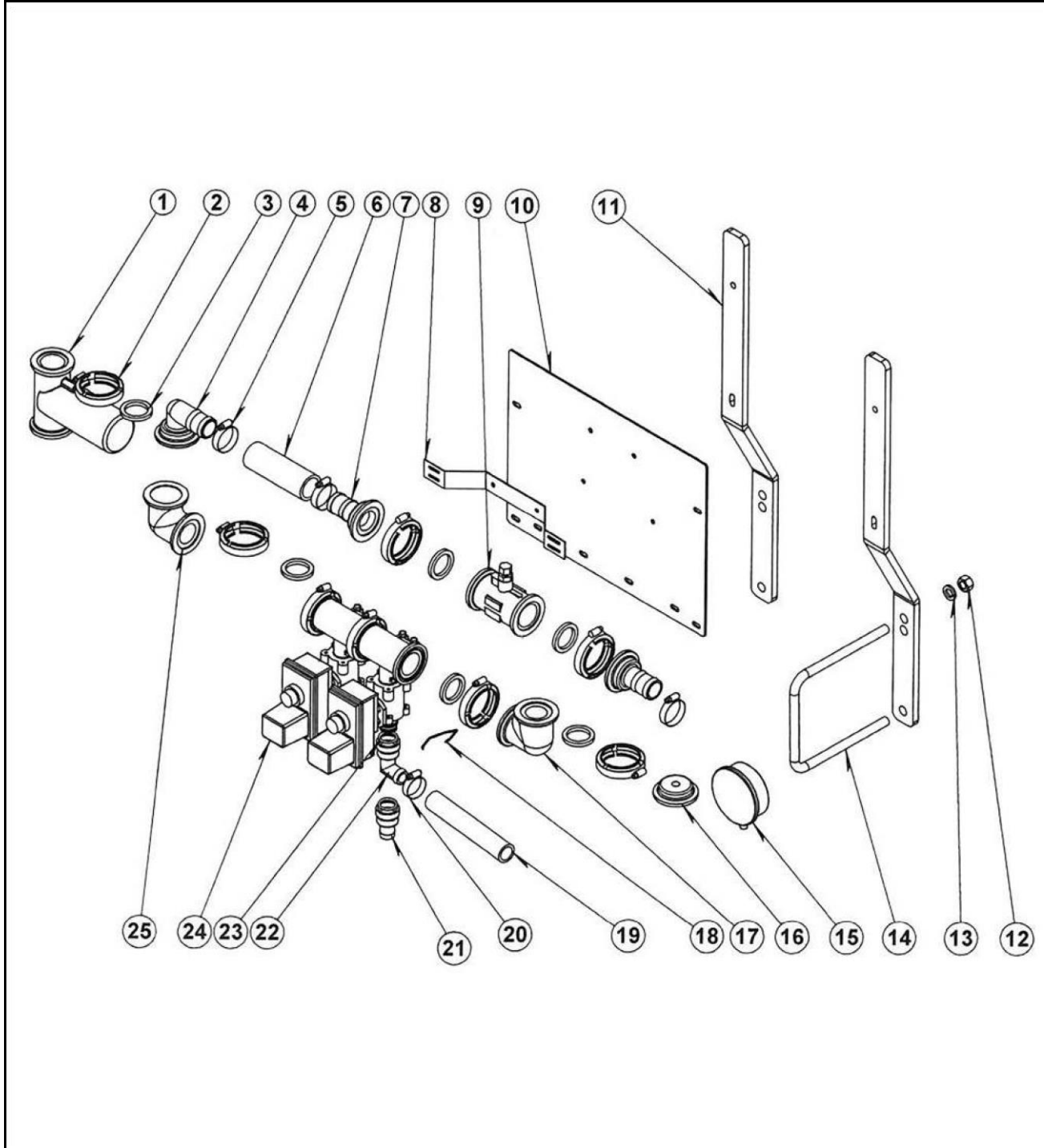

Parts List: Ball Valve Mount

ITEM	PART NO.	VENDOR PART NO.	QTY.	DESCRIPTION
1	631805	063-0171-894	1	CONTROL VALVE 1-1/2
2	540001	FC200	AR	CLAMP 2" STD PORT
3	530014	M150G	AR	GASKET 2" STD PORT
4	530080	M200150BRB90	1	MANIFOLD HOSE BARB 90
5	540016	64024	2	CLAMP, STAINLESS 1-1/2"
6	510014	1-1/2BH200	AR	HOSE 1-1/2" EPDM
7	530049	M200150BRB	1	MANIFOLD 2" STD TO HOSE BARB
8	631809		1	BRACKET, FLOW METER
9	631804	063-0171-793	1	FLOW METER 60P
10	3179		1	PANEL, CONTROLLER MOUNT
11	5729		2	MOUNT, BALL VALVE
12	216		4	NUT, HEX 5/8" ZP
13	253		4	WASHER, LOCK 5/8" ZP
14	590108		2	U-BOLT 7 X 7 BAR
14	596772M		2	U-BOLT 4 X 6 BAR
15	790020	FAST4154GXX160	1	GAUGE, FAST LOGO 160 PSI
16	530094	M200PLG025	1	MANIFOLD PLUG WITH 1/4" PORT
17	530089	M200CPG90SH	1	MANIFOLD ELBOW 90 SHORT
18	530193	CP37166-1-302SS	AR	RETAINING CLIP
19	510016	1BH200	AR	HOSE 1" EPDM
20	540016	64016	AR	CLAMP 1" HOSE
21	530189		AR	QUICK CONNECT STRAIGHT
22	530190	45529-1	AR	QUICK CONNECT 90 DEGREE
23	530198	CP7717-3-912-VI	AR	O-RING, VITON
24	500027		AR	VALVE 450BEC MANIFOLD (NARROW) (NON-FLOWBACK)
24	500028		AR	VALVE 450BEC MANIFOLD (WIDE) (NON-FLOWBACK)
24	500029	45*BEC	AR	VALVE 450BEC MANIFOLD (WIDE) (FLOWBACK)
25	530088	M200CPG90	1	MANIFOLD ELBOW, 90 DEGREE

Toolbar Plumbing

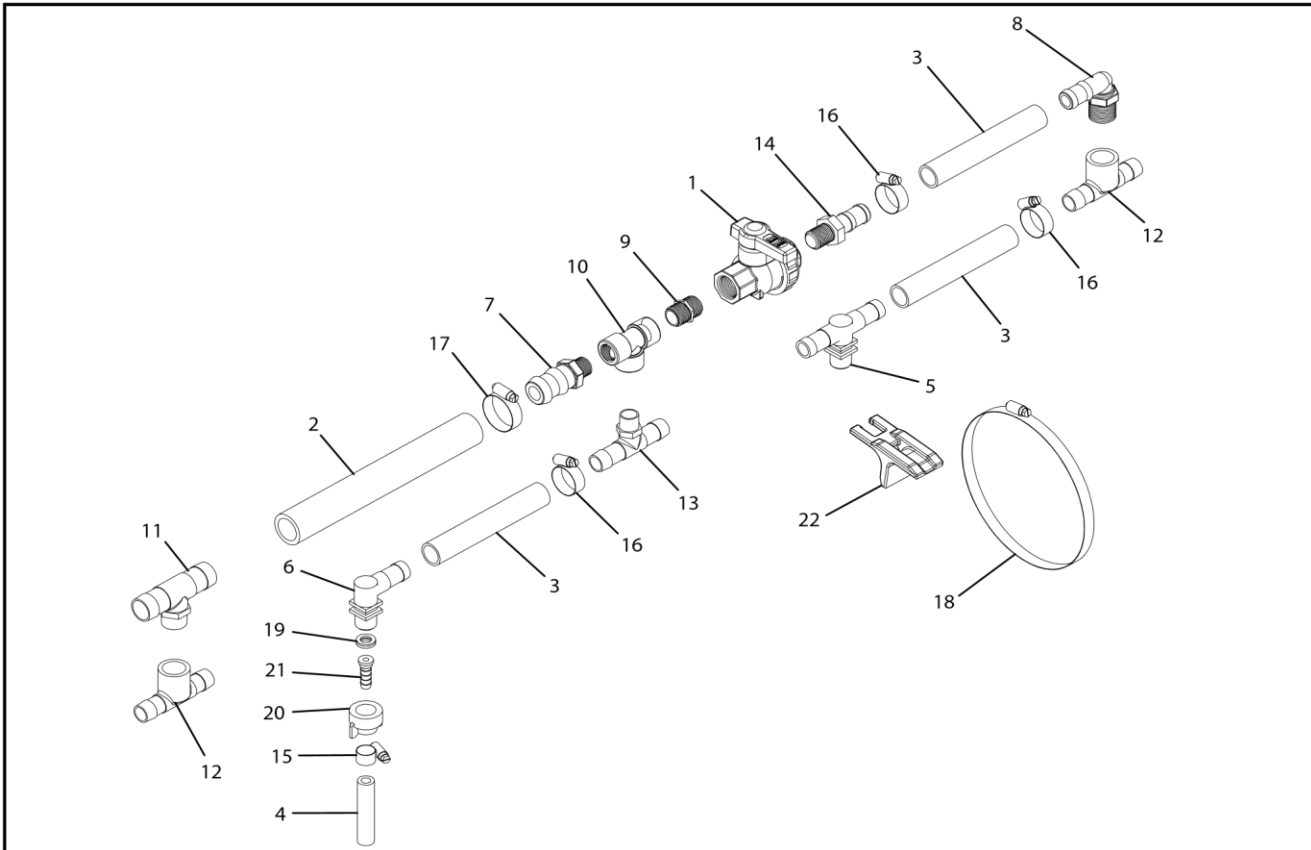

Parts List: Toolbar Plumbing

ITEM	PART NO.	QTY.	DESCRIPTION
1	500043	AR	VALVE, 3/4"
2	510016	AR	HOSE, 1" EPDM
3	510019	AR	HOSE, 3/4", EPDM
4	510020	AR	HOSE, 3/8", EPDM
5	520003	AR	NOZZLE, SINGLE
6	520004	AR	NOZZLE, DOUBLE
7	530039	AR	3/4" MPT X 1" HOSE BARB
8	530040	AR	3/4" MPT X 3/4" HOSE BARB 90°
9	530131	AR	3/4" MPT SHORT NIPPLE
10	530156	AR	TEE 3/4" NPT
11	530181	AR	3/4" MPT X 1" HOSE BARB TEE
12	530220	AR	3/4" FPT X 3/4" HOSE BARB TEE
13	530221	AR	3/4" MPT X 3/4" HOSE BARB TEE
14	530230	AR	3/4" MPT X 3/4" HOSE BARB
15	540011	AR	CLAMP, 3/8"
16	540013	AR	CLAMP 3/4"
17	540014	AR	CLAMP, HOSE SS 1" #16
18	540021	AR	CLAMP, 4 1/8 - 7"
19	590029	AR	SEAL, EPDM
20	590076	AR	CAP
21	590077	AR	CONNECTOR, HOSE BARB
22	590187	AR	MOUNT, PLUMBING

Raven Components

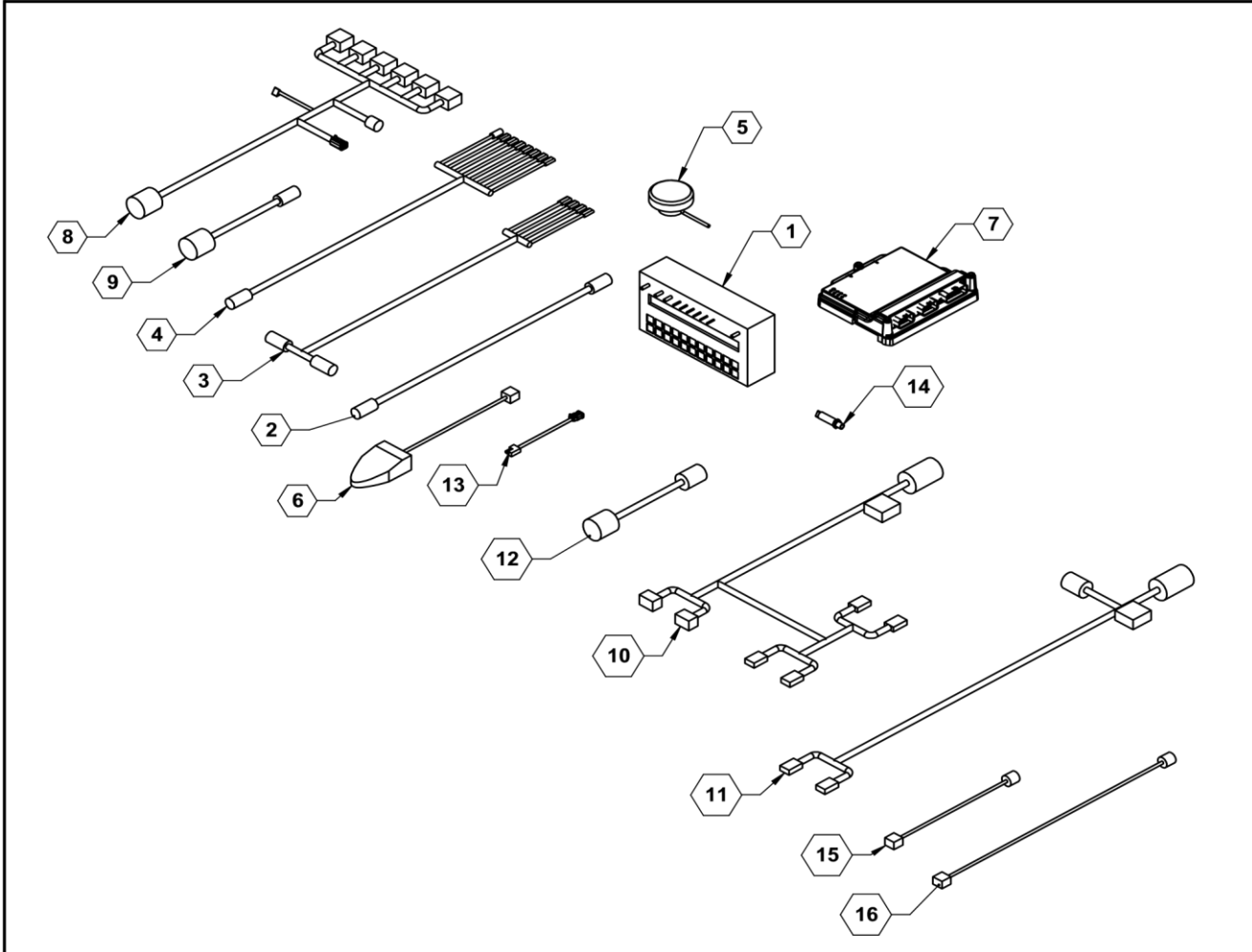

Parts List: Raven Components

ITEM	PART NO.	QTY.	DESCRIPTION
1	631803	AR	6 SECTION 450 CONSOLE
2	631814	AR	12' 16 PIN EXTENSION CABLE
3	631818	AR	10' 440 / 450 CONSOLE CABLE
4	631819	AR	16 PIN 6 SECTION CABLE
5	631832	AR	GPS SPEED SENSOR
6	631856	AR	FOOTSWITCH
7	632010	AR	RCM
8	632027	AR	47 PIN 6 SECTION CABLE
9	632028	AR	47 PIN TO 16 PIN ADAPTER
10	632029	AR	47 PIN RCM Y-CABLE
11	632031	AR	12' ISO TO IBIC CABLE
12	632033	AR	47 PIN TO 37 PIN ADAPTER
13	632034	AR	TRAILER TO DEUTSCH PLUG ADAPTER CABLE
14	632036	AR	PRESSURE TRANSDUCER
15	632061	AR	CABLE, FOOTSWITCH, 12'
16	632062	AR	CABLE FOOTSWITCH, 23'
NS	631802	AR	3 SECTION 440 CONSOLE

Control Harness 155-0171-085

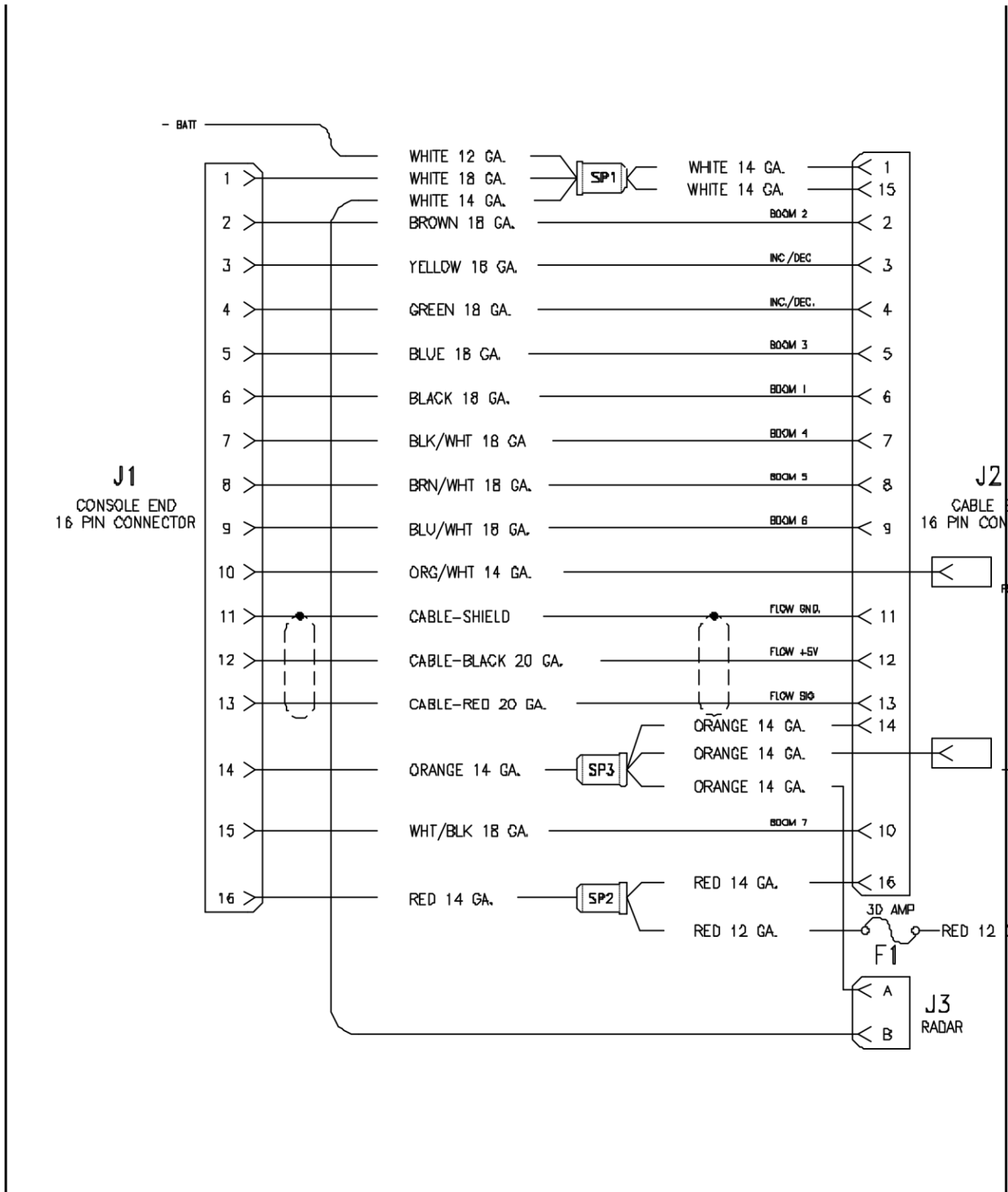

Control Harness 155-0159-856

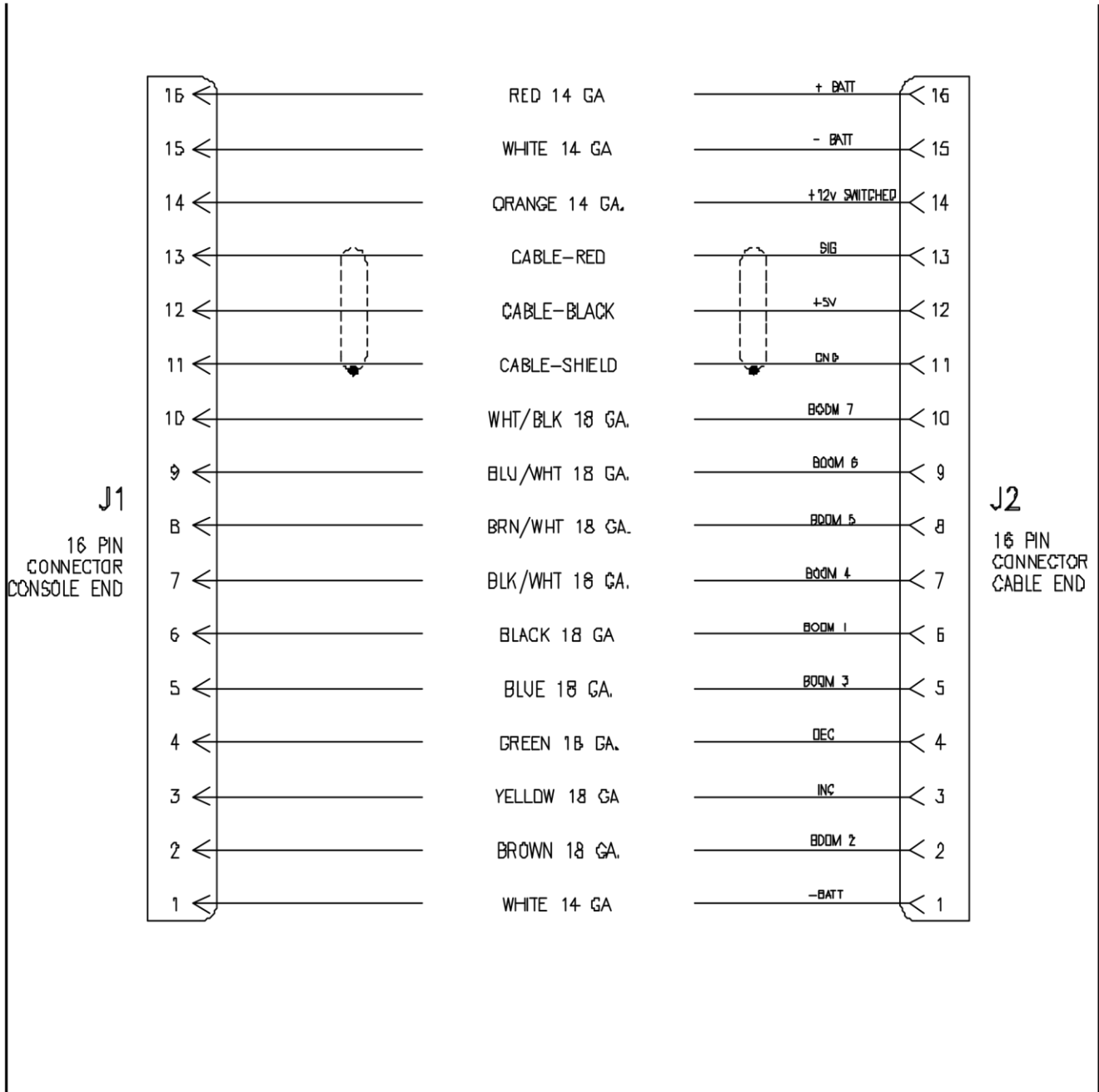

Control Harness 155-0171-086

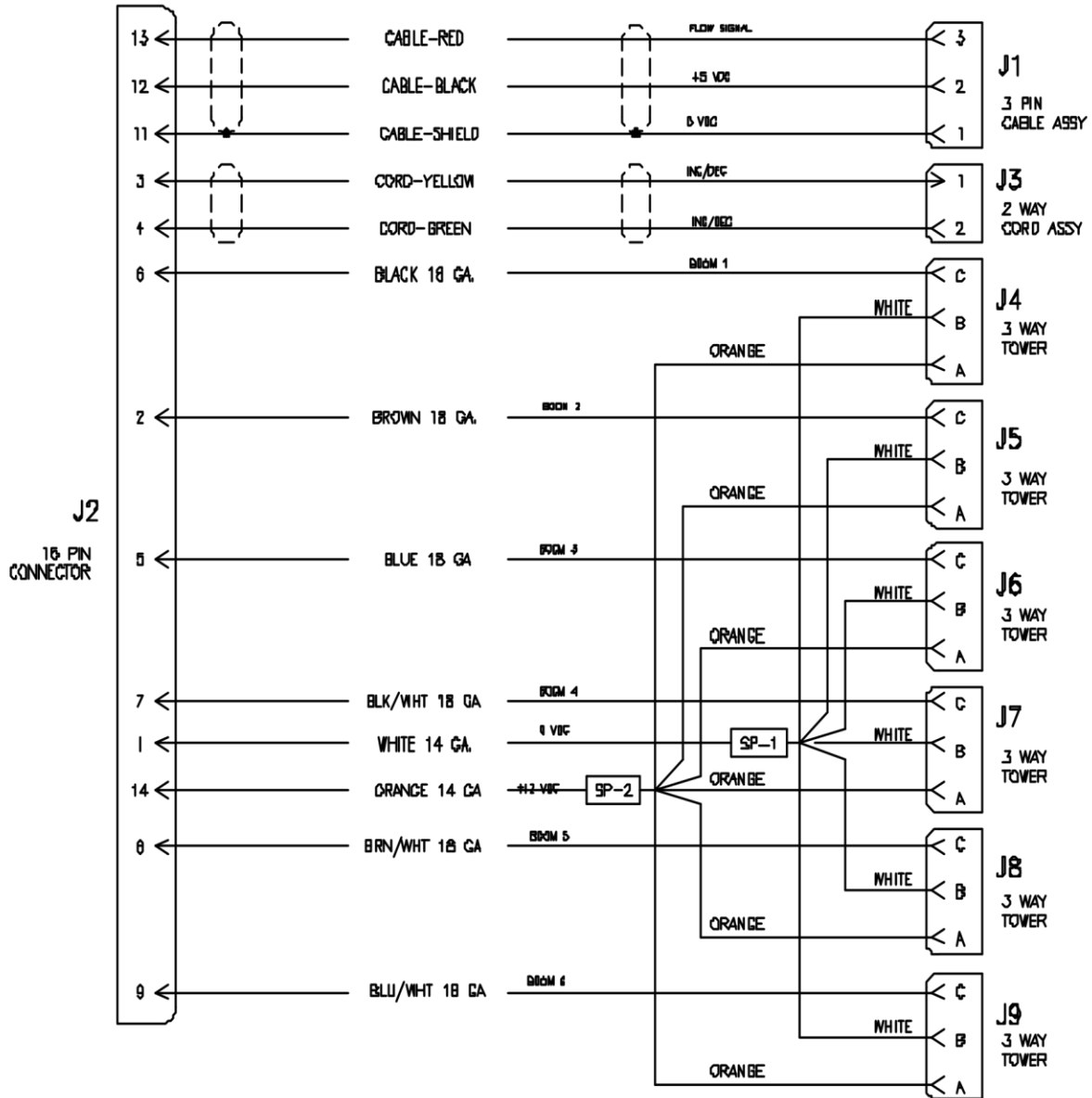

Hydraulic System for Pump

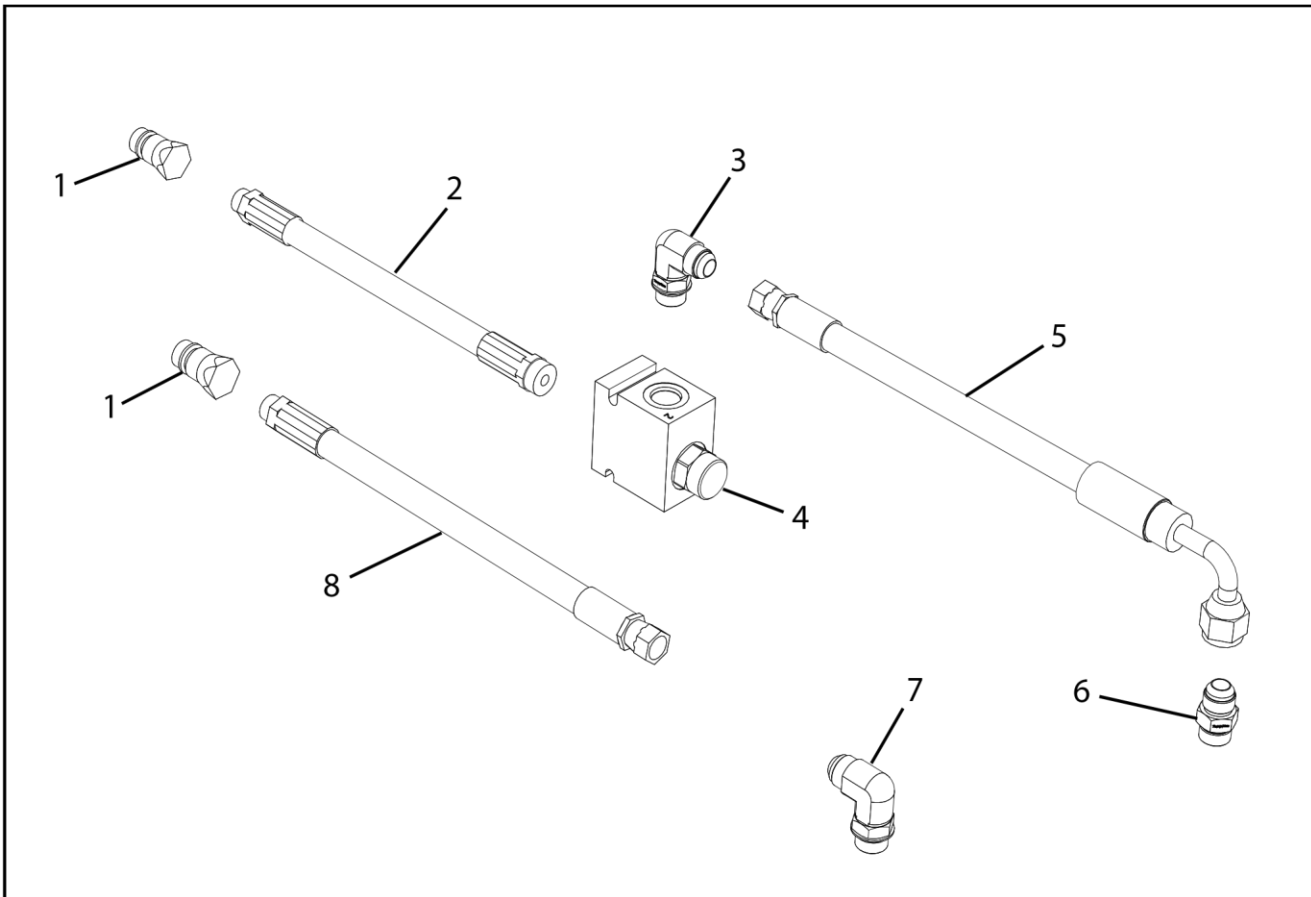

Parts List: Hydraulic System for Pump

ITEM	PART NO.	DESCRIPTION	8310	8313	8318	8324	ACE 150-206	HYPRO 93079
1	2-NV12-12SAE	HOSE TIP	2	2	2	2		
2	PA600053-1	HOSE PRESSURE TO VALVE	1	1				
	PA600054-1	HOSE PRESSURE TO VALVE			1	1		
3	610086	HYDRAULIC FITTING 6801-8-10	1	1	1	1		
4	610100	PC VALVE 7.5 GPM					1	
	610099	PC VALVE 13 GPM						1
5	PA600053-2	HOSE PRESSURE TO PUMP	1	1				
	PA600054-2	HOSE PRESSURE TO PUMP			1	1		
6	610060	HYDRAULIC FITTING 6400-08-10	1	1				
	610106	HYDRAULIC FITTING 6400-10-10			1	1		
7	610102	HYDRAULIC FITTING 6801-10-10	1	1	1	1		
8	PA600053-3	HOSE PUMP RETURN	1	1				
	PA600054-3	HOSE PUMP RETURN			1	1		

813P Hydraulic System

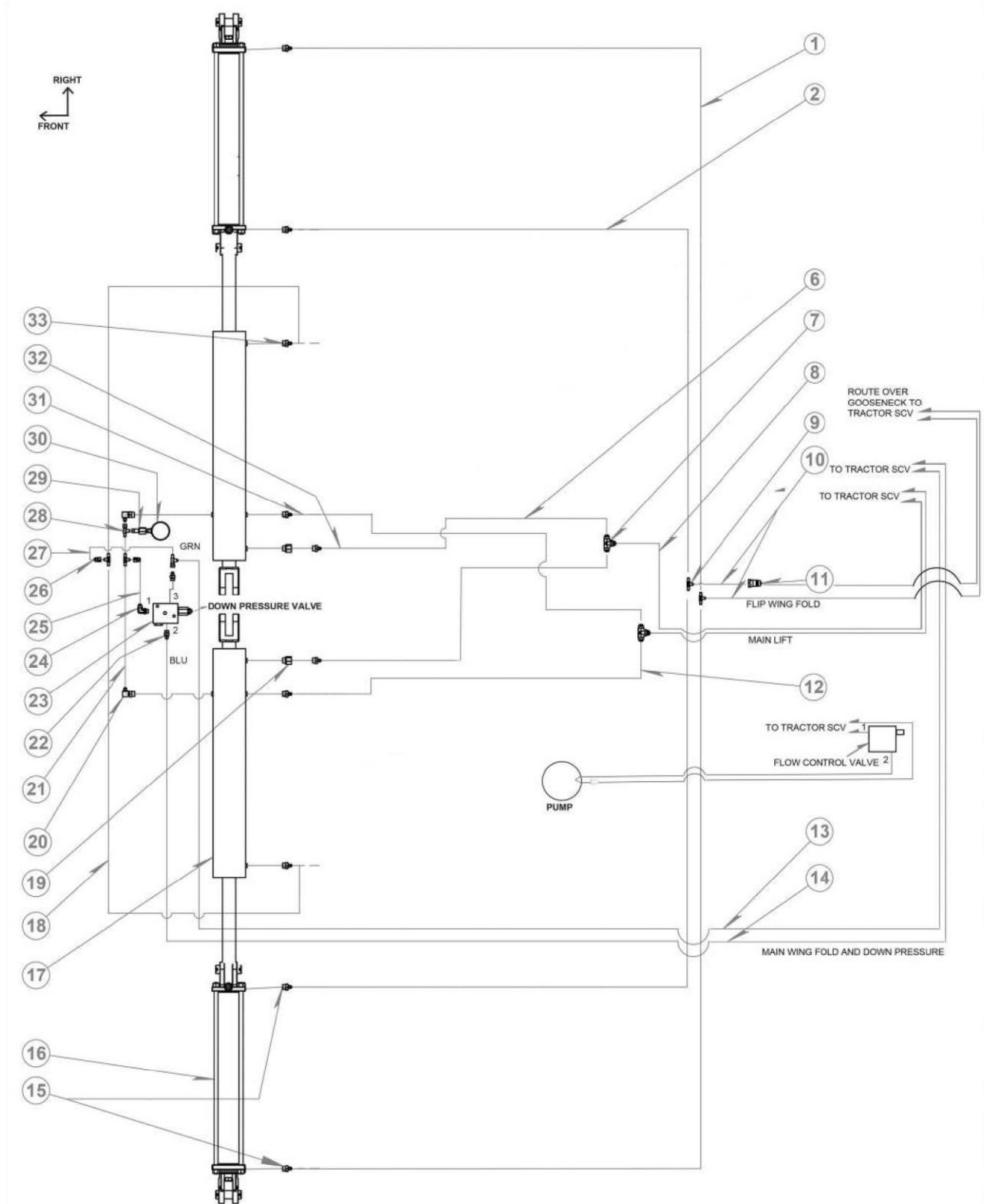

Parts List: 813P Hydraulic System

ITEM	VENDOR PART #	PART #	DESCRIPTION	QTY.
1		600045-7-ZN	FDM4R17-4FJXZ-4FJX90MZ-220	2
2		600045-6-ZN	FDM4R17-4FJXZ-4FJX90MZ-200	2
6		600045-10-ZN	FDM6R17-6FJX90MZ-8FJXZ-68	2
7	TO-2603-08-08-08	610004	FITTING ADAPTER TEE8JIC	2
8		FDM0025-ZN	FDM8R17-8MBOZ-8FJXZ-183	2
9	TO-2603-04-04-04	610003	FITTING ADAPTER JIC TEETO-2603-04-04-04	2
10		FDM0055-ZN	FDM4R17-8MBOZ-4FJX90MZ-305	2
11	2-NV12-12SAE-M	520048	TIP HYDRAULIC ISO	6
12		600045-11-ZN	FDM6R17-6FJX90MZ-8FJXZ-80	2
13		600045-4A-ZN	FDM6R17-8MBOZ-6FJXZ-90M-281	1
14		600045-3-ZN	FDM6R17-8MBOZ-6FJXZ-273	1
15	TO-6801-6-8-S	610045	FITTING ADAPTER 8ORB TO 4JIC R0.045 (USED ON 620004)	4
16	MI671326	620057	CYLINDER 30TD16-150 3" X 16" STROKE	2
NS	MI649208		KIT SEAL 3.0 BORE X 1.5 ROD	AR
17		620030	CYLINDER, MAIN WING (813P)	2
NS		649080	KIT, SEAL 5.0 BORE X 2.0 ROD	AR
18		FDM0048-ZN	FDM4R17-4FJXZ-4FJX90MZ-85	2
19	AF661182047	610096	FITTING ADAPTER 8ORB M/F .047ORIFICE	2
20	TO-6801-04-08	610029	FITTING ADAPTER 8ORB TO 4JIC90°	2
21		600056-1-ZN	FDM4R17-4FJXZ-4FJXZ-63	1
22	TO-6400-06-06	610010	FITTING ADAPTER 6ORB TO6JIC	1
23	AFFAST194288	630038	BLOCK DOWN PRESSURE (1PDCP25-PT-12S)	1
24	TO68010606	610078	FITTING ADAPTER 6ORB TO 6JIC90°	1
25		600045-1A-ZN	FDM6R17-6FJXZ-6FJX90MZ-25	2
26	TO-2406-6-4	610002	FITTING ADAPTER 2406-04-06	1
27		600045-2A-ZN	FDM6R17-6FJXZ-6FJX90MZ-25.5	1
28	TO-6602-04-04-04	610026	FITTING ADAPTER JIC SWIVEL RUN TEETO-6602-04-04-04	1
29	TO-6506-4-4-S	610025	FITTING ADAPTER 6506-4-4	1
30	AF2141GXB3000	790052	GAUGE PRESSURE 0-3000 PSI	1
31		600056-2-ZN	FDM4R17-6FJXZ-4FJX90MZ-50	1
32		600056-3-ZN	FDM4R17-6FJXZ-4FJX90MZ-60	2
33	TO-6400-04-08	610009	FITTING ADAPTER 8ORB TO4JIC	2

833P Hydraulic System

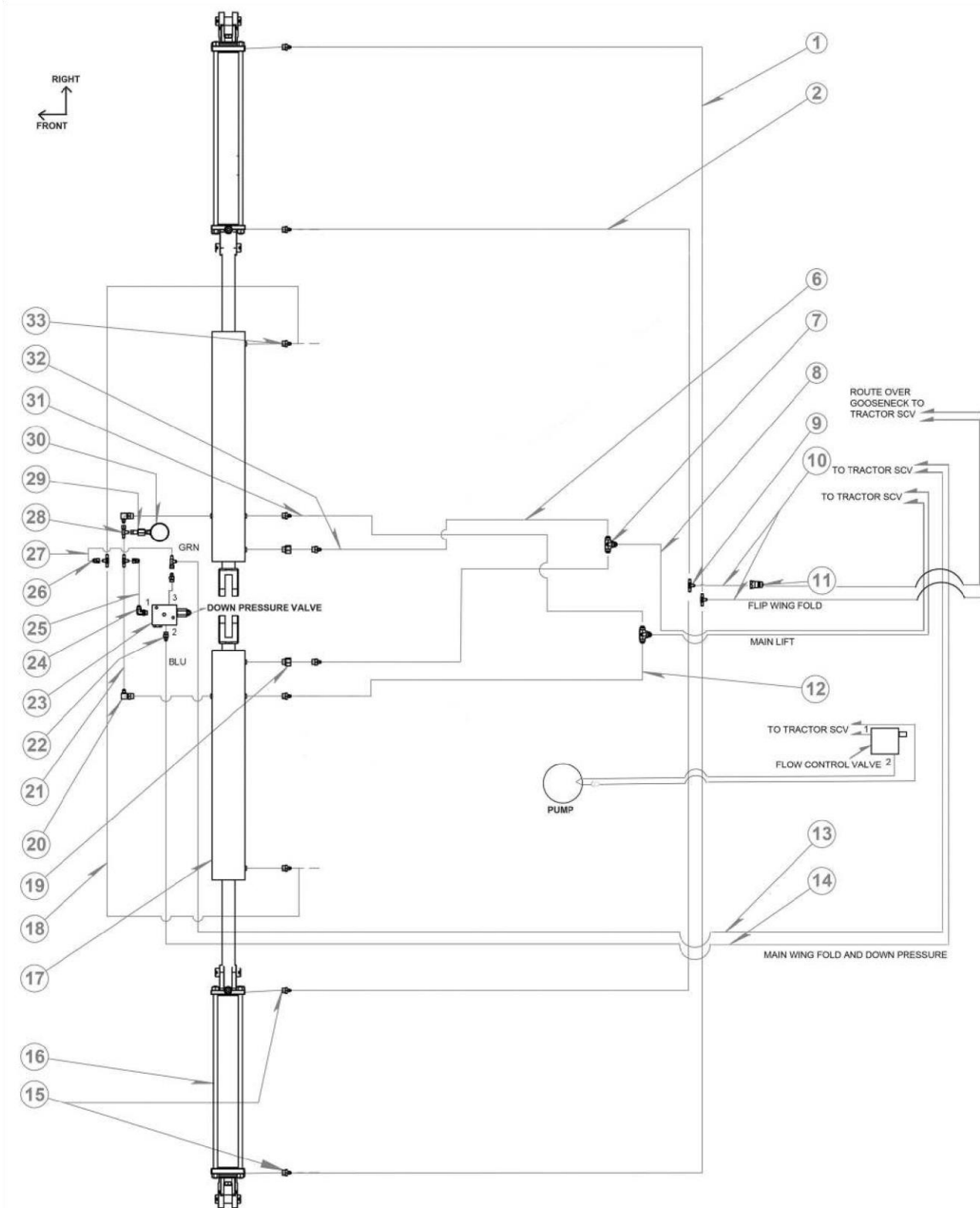

Parts List: 833P Hydraulic System

ITEM	PART #	DESCRIPTION	QTY. 12 ROW	ADD FOR 16 ROW OPT
1	600043-6	FDM4R17-4FJX-4FJX90M-153		2
2	600043-5	FDM4R17-4FJX-4FJX90M-126		2
6	600043-4	FDM6R17-6FJX90M-8FJX-90	2	
7	610004	FITTING ADAPTER TEE 8JIC	2	
8	600043-1	FDM8R17-8MBO-8FJX-156	2	
9	610003	FITTING ADAPTER JIC TEE TO-2603-04-04-04		2
10	600043-2	FDM4R17-8MBO-4FJX90M-306		2
11	520048	2-NV12-12SAE-M	4	2
12	600043-3	FDM6R17-6FJX90M-8FJX-102	2	
13	600043-18	FDM6R17-8MBO-6FJX-90M-293	1	
14	600043-13	FDM6R17-8MBO-6FJX-285	1	
15	610045	FITTING ADAPTER 8ORB TO 4JIC R0.045 (USED ON 620004)	4	
16	620004	CYLINDER 30TD24-150 3" X 24" STROKE	2	
NS	649208	KIT SEAL 3.0 BORE X 1.5 ROD		
17	620027	CYLINDER DUAL FUCTION 45WD22.5 X 1.81 WK	2	
NS	PMI0002	KIT SEAL 4.5 BORE X 2.0 ROD		
18	600043-17	FDM4R17-4FJX-4FJX-32	2	
19	610094	FITTING ADAPTER 8ORB M/F .047 ORIFICE	2	
20	610029	FITTING ADAPTER 8ORB TO 4JIC 90°	2	
21	600043-17	FDM4R17-4FJX-4FJX-32	2	
22	610010	FITTING ADAPTER 6ORB TO 6JIC	1	
23	630038	BLOCK DOWN PRESSURE (1PDCP25-PT-12S)	1	
24	610078	FITTING ADAPTER 6ORB TO 6JIC 90°	1	
25	600043-14	FDM6R17-6FJX-6FJX90M-9	1	
26	TO24060406	FITTING ADAPTER 2406-04-06	2	
27	600048-1-ZN	FDM6R17-6FJX-6FJX90M-6.5		
28	600043-17	FDM4R17-4FJX-4FJX-32	1	
29	610026	FITTING ADAPTER JIC SWIVEL RUN TEE TO-6602-04-04-04	1	
30	610025	FITTING ADAPTER 6506-4-4	1	
31	790052	GAUGE PRESSURE 0-3000 PSI	1	
32	600043-19	FDM4R17-6FJX-4FJX90M-45	2	
33	600043-8	FDM4R17-6FJX-4FJX90M-61	2	
34	600041-5	FDM4R17-4FJX-4FJX90M-56	1	

813P Hydraulic Schematic

813P HYDRAULIC WING KICK

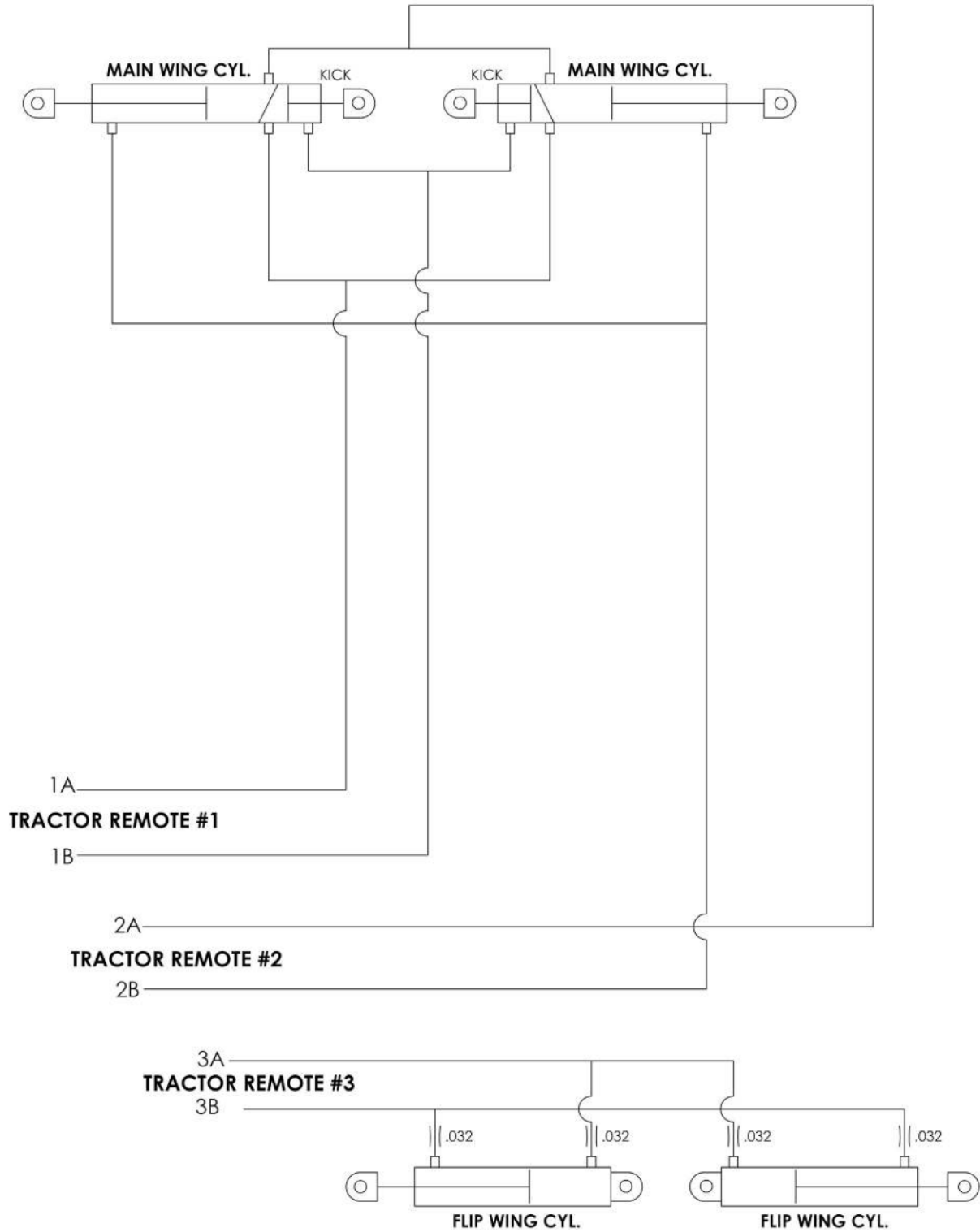

Parts List: 813P Hydraulic Schematic

ITEM	PART NO.	QTY.	DESCRIPTION
1	620030	2	CYLINDER, MAIN WING (813P)
1	649080	1	KIT, SEAL 5.0 BORE X 2.0 ROD
2	620057	2	CYLINDER, FLIP WING (813P)
2	MI649208	1	KIT, SEAL 3.0 BORE X 1.5 ROD
3	520048	8	2-NV12-12SAE-M - HYDRAULIC TIP
4	600051-1-ZN	6	HOSE, HYDRAULIC, FDM4R17-8MBO-4FJX - TRAILER TO FLIP AND MAIN WINGS
5	600051-2-ZN	1	HOSE, HYDRAULIC, FDM4R17-4FJX-4FJX90M - LEFT FLIP RAM
6	600051-3-ZN	1	HOSE, HYDRAULIC, FDM4R17-4FJX-4FJX90M - LEFT FLIP BASE
7	600051-4-ZN	1	HOSE, HYDRAULIC, FDM4R17-4FJX-4FJX90M - RIGHT FLIP RAM
8	600051-5-ZN	1	HOSE, HYDRAULIC, FDM4R17-4FJX-4FJX90M - RIGHT FLIP BASE
9	600051-6-ZN	1	HOSE, HYDRAULIC, FDM4R17-4FJX-4FJX90M - RIGHT WING KICK RAM
10	600051-7-ZN	1	HOSE, HYDRAULIC, FDM4R17-4FJX-4FJX90M - RIGHT WING KICK BASE
11	600051-8-ZN	1	HOSE, HYDRAULIC, FDM4R17-4FJX-4FJX90M - LEFT WING KICK RAM
12	600051-9-ZN	1	HOSE, HYDRAULIC, FDM4R17-4FJX-4FJX90M - LEFT WING KICK BASE
13	600051-10-ZN	1	HOSE, HYDRAULIC, FDM4R17-4FJX-4FJX - RIGHT MAIN FOLD BASE
14	600051-11-ZN	1	HOSE, HYDRAULIC, FDM4R17-4FJX-4FJX90M - RIGHT MAIN FOLD RAM
15	600051-12-ZN	1	HOSE, HYDRAULIC, FDM4R17-4FJX-4FJX - LEFT MAIN FOLD BASE
16	600051-13-ZN	1	HOSE, HYDRAULIC, FDM4R17-4FJX-4FJX90M - LEFT MAIN FOLD RAM
17	600046-13-ZN	1	HOSE, HYDRAULIC, FDM8R17-8MBO-10MBO90
18	600046-14-ZN	1	HOSE, HYDRAULIC, FDM10R17-8MBO-10MBO90

833P Hydraulic Schematic

833P HYDRAULIC WING KICK

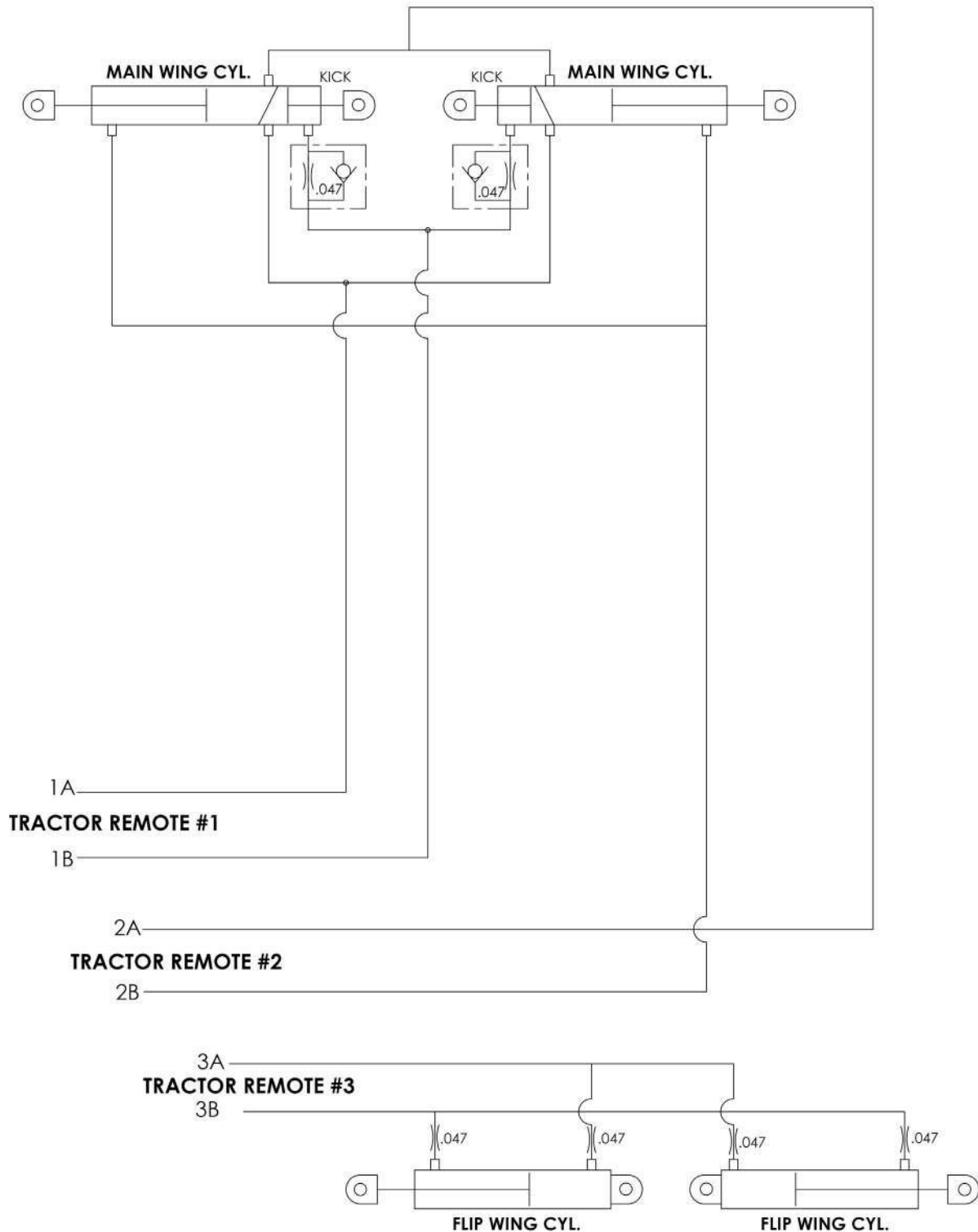

Parts List: 833P Hydraulic Schematic

ITEM	PART NO.	QTY.	DESCRIPTION
1	620027	2	CYLINDER, MAIN WING (833P)
1	MP-PMI0002	1	Kit Seal 4.5 Bore X 2.0 Rod
2	620004	2	CYLINDER, FLIP WING (833P)
2	649208	1	KIT SEAL 3.0 BORE X 1.5 ROD
3	520048	8	2-NV12-12SAE-M ISO TIP
4		2	2406-4-6
5	600046-1A-ZN	2	HOSE, HYDRAULIC, FDM6R17-6FJXZ-8MBOZ-71
6	600046-2A-ZN	4	HOSE, HYDRAULIC, FDM4R17-4FJXZ-8MBOZ-71
7	600046-3-ZN	1	HOSE, HYDRAULIC, FDM4R17-4FJXZ-4FJX90MZ-145
8	600033-7-ZN	1	HOSE, HYDRAULIC, FDM4R17-4FJXZ-4FJX90MZ-118
9	600046-4-ZN	1	HOSE, HYDRAULIC, FDM4R17-4FJXZ-4FJX90MZ-159
10	600046-5-ZN	1	HOSE, HYDRAULIC, FDM4R17-4FJXZ-4FJX90MZ-132
11	600046-6-ZN	1	HOSE, HYDRAULIC, FDM4R17-4FJXZ-4FJX90MZ-36
12	600046-7-ZN	1	HOSE, HYDRAULIC, FDM4R17-4FJXZ-4FJX90MZ-40
13	FDM 0019-ZN	1	HOSE, HYDRAULIC, FDM4R17-4FJXZ-4FJX90MZ-21
14	600046-8-ZN	1	HOSE, HYDRAULIC, FDM4R17-4FJXZ-4FJX90MZ-26
15	600046-9-ZN	1	HOSE, HYDRAULIC, FDM4R17-4FJXZ-4FJXZ-41
16	600046-10-ZN	1	HOSE, HYDRAULIC, FDM4R17-4FJXZ-4FJX90MZ-66
17	600046-11-ZN	1	HOSE, HYDRAULIC, FDM4R17-4FJXZ-4FJXZ-27
18	600046-12-ZN	1	HOSE, HYDRAULIC, FDM4R17-4FJXZ-4FJX90MZ-51
19	600046-13-ZN	1	HOSE, HYDRAULIC, FDM8R17-8MBO-10MBO90-115
20	600046-14-ZN	1	HOSE, HYDRAULIC, FDM10R17-8MBO-10MBO90-115
21	600046-15-ZN	2	HOSE, HYDRAULIC, FDM4R17-4FJXZ-4FJX90MZ-20

Lighting

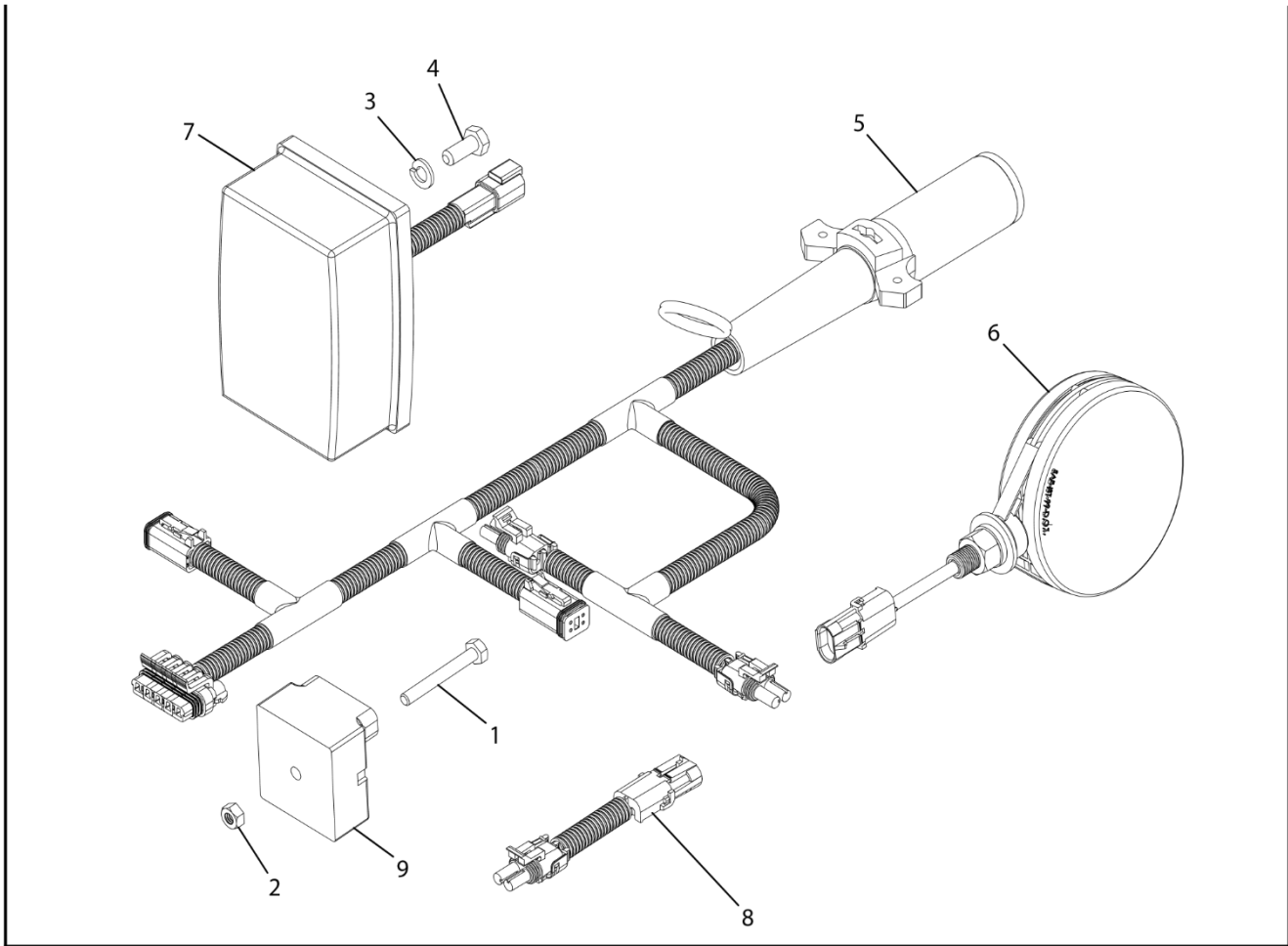

Parts List: Lighting

ITEM	PART NO.	QTY.	DESCRIPTION
1	104	1	BOLT, 1/4 X 2" GRADE 5 ZP
2	235	1	NUT, CENTERLOCK, 1/4" ZP
3	249	4	WASHER, LOCK, 5/16" ZP
4	590229	4	BOLT, 8 X 20 MM 8.8 ZP
5	740023	1	APPLICATOR LIGHT WIRING HARNESS
6	740024	2	AMBER WARNING LIGHT
7	740025	2	RED TAILLIGHT
8	740029	2	EXTENSION
9	740031	1	LIGHT MODULE



ILLUSTRATED PARTS LIST

NOTES



FAST Ag Solutions
4130 Commerce Boulevard
Windom, MN 56101
1-800-772-9279 Toll Free
1-507-427-3861 Voice
1-507-427-3030 Fax www.fastsprayers.com