



***Fendt 900 Vario MT &
Challenger MT738, MT740, & MT743***
TRACK TANKS
INSTALLATION and PARTS MANUAL



INSTALLATION & PARTS





Limited Warranty

Fast Ag Solutions warrants to the buyer that the new machinery is free from defects in material and workmanship.

This warranty is only effective as to any new machinery which has not been altered, changed, repaired or treated since its delivery to the buyer, other than by Fast Ag Solutions or its authorized dealers or employees, and does not apply to accessories, attachments, tools or parts, sold or operated with the new machinery, if they have not been manufactured by Fast Ag Solutions.

Fast Ag Solutions shall only be liable for defects in the materials or workmanship attributable to faulty material or bad workmanship that can be proved by the buyer, and specifically excludes liability for repairs arising as a result of normal wear and tear of the new machinery or in any other manner whatsoever, and without limiting the generality of the foregoing, excludes application or installation of parts not completed in accordance with this operator's manual, specifications, or printed instructions.

Written notice shall be given by registered mail, to the Manufacturer within seven (7) days after the defect shall have become apparent or the repairs shall have become necessary, addressed as follows:

Fast Ag Solutions
4130 Commerce Boulevard
Windom, MN 56101

This warranty shall expire one (1) year after the date of delivery of the new machinery.

If these conditions are fulfilled, Fast Ag Solutions shall at its own cost and at its own option either repair or replace any defective parts provided that the buyer shall be responsible for all expenses incurred as a result of repairs, labor, parts, transportation or any other work, unless Fast Ag Solutions has authorized such expenses in advance.

The warranty shall not extend to any repairs, changes, alterations, or replacements made to the new equipment other than by Fast Ag Solutions or its authorized dealers or employees.

This warranty extends only to the original owner of the new equipment.

Rubber parts (including tires, hoses, grommets) are not warrantied.

This warranty is limited to the terms stated herein and is in lieu of any other warranties whether express or implied, and without limiting the generality of the foregoing, excluded all warranties, express or implied or conditions whether statutory or otherwise as to quality and fitness for any purpose of the new equipment. The Manufacturer disclaims all liability for incidental or consequential damages.

This Track Tanks is subject to design changes and Fast Ag Solutions shall not be required to retrofit or exchange items on previously sold units except at its own option.

Warranty void if not registered.



FAST TRACK TANKS

Warranty Registration

This form must be filled out by the dealer and signed by both the dealer and the customer at the time of delivery.

Customer Name					
Address					
City		State		Zip	
Phone					

Dealer Name					
Address					
City		State		Zip	

Tank Model					
Serial Number					
Delivery Date					

Warranty Inspection Report

DEALER INSPECTION REPORT

- All Fasteners Tight
- Fertilizer Hoses and Fittings Free and Tight
- Frame and Tanks Level

SAFETY

- Safety Chain Installed
- All Guards Installed
- All Safety Signs Installed
- Reflectors, SMV, and Lights Clean
- Review Operating and
- Safety Instructions

I have thoroughly instructed the buyer on the above-described equipment in which review included the Manual content, equipment care, adjustments, safe operation, and applicable warranty policy.

Date _____
Dealer's Rep. Signature _____

The above equipment and Manual have been received by me, and I have been thoroughly instructed as to care, adjustments, safe operation, and applicable warranty policy.

Date _____
Owner's Signature _____

White - FAST
Yellow - Dealer
Pink - Customer



INSTALLATION & PARTS

FAST Fendt 900 Vario MT Series Tank

TANK SERIAL NUMBER _____

DATE PURCHASED _____ / _____ / _____

General Information

All rights, especially copying and distribution rights are reserved. No part of this publication may be reproduced in any form or by any means, electronic or mechanical, including photocopying, without express written permission from Fast Ag Solutions.

Parts information in this manual represents components installed when product was manufactured based upon the best available information. Modifications made subsequent to initial delivery are not included. Always verify the parts and color required when ordering parts.

If you have any questions, please contact your Fast Ag Solutions Parts and Service Department.

Explanation of Lists

The Manual is organized as follows:

Table of Contents

INSTALLATION

PARTS

TORQUE SPECIFICATIONS

The parts lists are broken down into sub-assemblies and listed in four (4) columns:

- **ITEM** - These numbers are found on the illustration associated with the parts list.
 - NS - This item is NOT SHOWN, included for reference.
- **QTY.** - This is the quantity of parts needed in an assembly.
 - AR - The quantity of this item is applied AS REQUIRED for the location.
- **PART NO.** - These are the part numbers associated with the ITEM.
- **DESCRIPTION** - This is the description of the part.



Table of Contents

Section	Page
<i>Warranty Registration</i>	<i>iv</i>
<i>Warranty Inspection Report</i>	<i>iv</i>
<i>General Information</i>	<i>vi</i>
Table of Contents	vii
DISASSEMBLY	9
<i>Remove Step Assembly and LH Turn Signal</i>	<i>9</i>
<i>Remove RH Turn Signal and Exhaust Components</i>	<i>10</i>
<i>Remove the Radar Sensor and Deflector Plate</i>	<i>10</i>
INSTALLATION	11
<i>Install Receiver Mounting Brackets</i>	<i>11</i>
<i>Install Radar</i>	<i>12</i>
<i>Install Rear Tank Supports</i>	<i>12</i>
<i>Position the Tractor and Tanks</i>	<i>12</i>
<i>Install Underside Supports</i>	<i>13</i>
<i>Install Straps and Nylon Protector</i>	<i>14</i>
<i>Install Step Assembly</i>	<i>14</i>
<i>Install Plumbing Components</i>	<i>15</i>
PARTS	16
<i>Tanks & Plumbing</i>	<i>16</i>
Parts List 35500: Tanks & Plumbing	<i>21</i>
<i>Barrier Chain</i>	<i>23</i>
Parts List 35104: Barrier Chain	<i>23</i>
<i>F/C SS Riser</i>	<i>24</i>
Parts List 35190: F/C SS Riser	<i>24</i>
<i>Quick Fill, 2"</i>	<i>25</i>
Parts List 35254: Quick Fill, 2"	<i>25</i>
<i>Quick Fill, 3"</i>	<i>26</i>
Parts List 35255: Quick Fill, 3"	<i>26</i>
<i>Hardware</i>	<i>27</i>
Parts List 590892: Hardware	<i>29</i>

TORQUE SPECIFICATIONS	30
<i>Metric Bolt and Screw Torque Values</i>	<i>30</i>
<i>Unified Inch Bolt and Screw Torque Values</i>	<i>31</i>



DISASSEMBLY

Remove Step Assembly and LH Turn Signal

⚠ WARNING: Step assembly weighs approximately 300 lbs. Use an appropriate lifting device to prevent injury.

1. Raise the tractor's hood and remove its side panels.
2. Unplug the connectors for the Step Actuator and front-left turn signal (if equipped.) Save for future use.
3. Loosen the four set bolts (1) securing the Step Assembly to the ladder mount tubes.

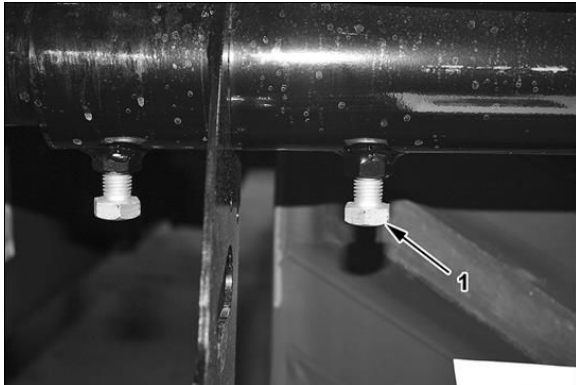

4. Attach a lifting device to the step assembly.
5. Remove the Step Assembly and save for future use.
6. Remove the four M19 head bolts (2) retaining the ladder mount tube (3). Remove and discard all.

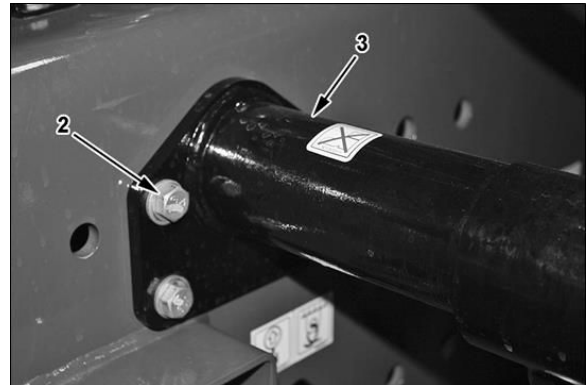

7. Repeat this process for the bolts (4) and lower step tube (5).

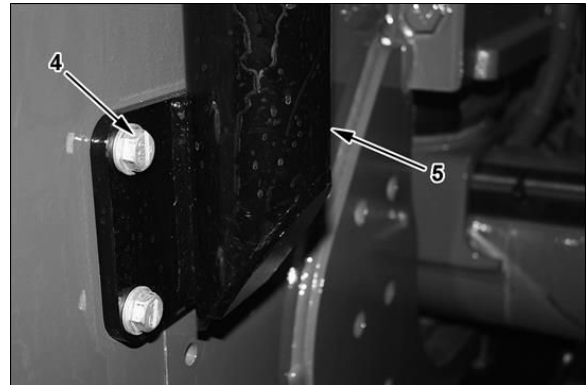

Remove RH Turn Signal and Exhaust Components

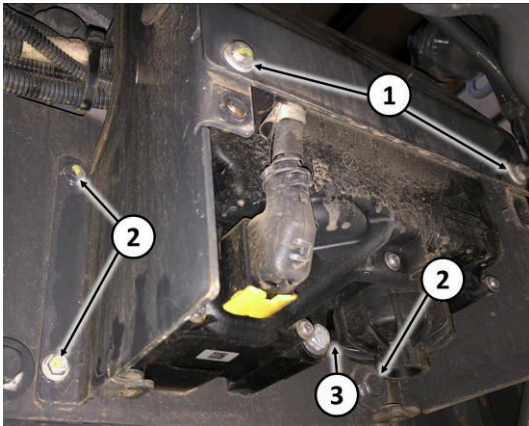
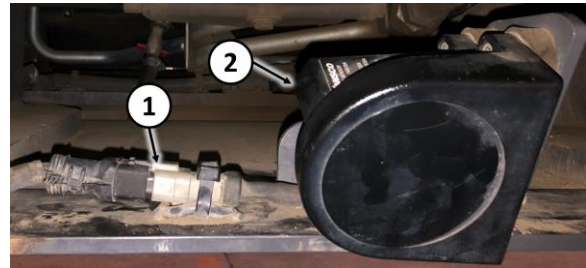

Figure 1: Inside the Left Frame Rail

1. Unplug the connector for the front-right turn signal.
2. Remove the three bolts retaining the right turn signal and bracket. Save for future use.
3. Remove eight M10 head bolts (1) from the DEF Pump Cover plates.
4. Remove the four M16 head bolts (2) securing the DEF Pump (3) to the tractor's frame. Use a bungee cord to suspend the DEF Pump and prevent stressing the DEF Pump hose.

Remove the Radar Sensor and Deflector Plate



1. Unplug the Radar Sensor's connector (1).
2. Remove the three M10 head bolts (3) securing the Radar Sensor (2). Save for future use.



3. Remove the four M19 head bolts securing the Deflector Plate (4). Save for future use.

INSTALLATION

Install Receiver Mounting Brackets

⚠ WARNING: Mounting bracket weighs approximately 75 lbs. Use an appropriate lifting device to prevent injury.

1. Install the left-side mounting bracket (1) on the tractor with 3/4" x 2" GR8 bolts (2) and flange nuts. Refer to the [torque charts](#) in this Manual for bolt torque values.

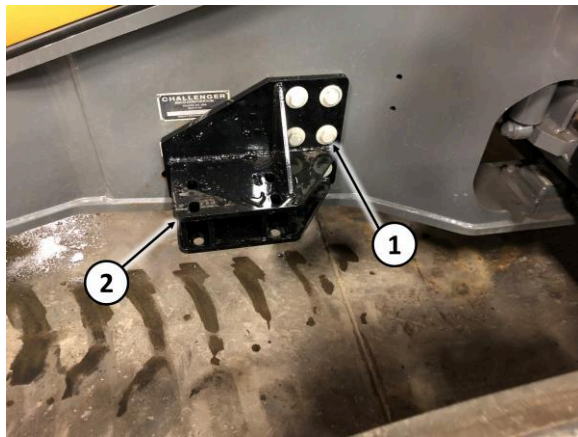

2. Repeat Step 1 with the right-side mounting bracket (3).



3. Place the rubber isolators (4) on the top and bottom of the bracket.
4. Place the plate (5) on top of the isolator and insert four 3/4" x 9" GR5

bolts (6) through the plate and both isolators.

5. Repeat Steps 3 and 4 for the left-hand side receiver mounting bracket.

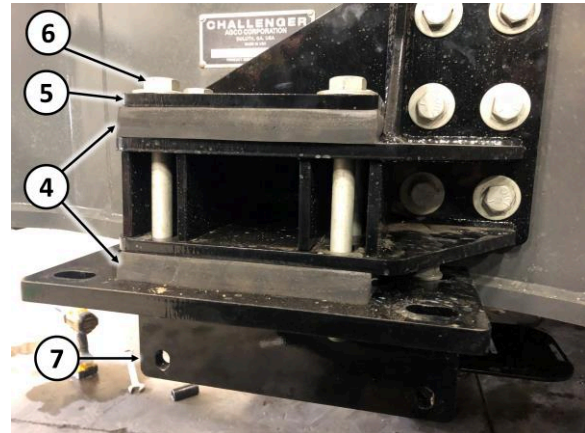

⚠ WARNING: Receiver mounting tube weighs approximately 150 lbs. Use an appropriate lifting device to prevent injury.

6. Raise and center the receiver mounting tube (7) into position with the radar bracket to the rear and install eight center-lock nuts (8).



7. Tighten all eight bolts equally (1/8" – 1/4") so some bulge is seen on the rubber isolators.
8. Reinstall the DEF Pump and Cover.

Install Radar

1. Attach the radar (3) to its FAST mounting bracket (1) with existing hardware (2).
2. Radar calibration may be necessary.

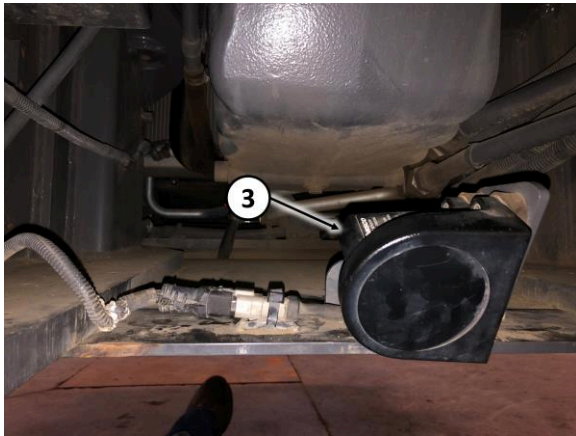
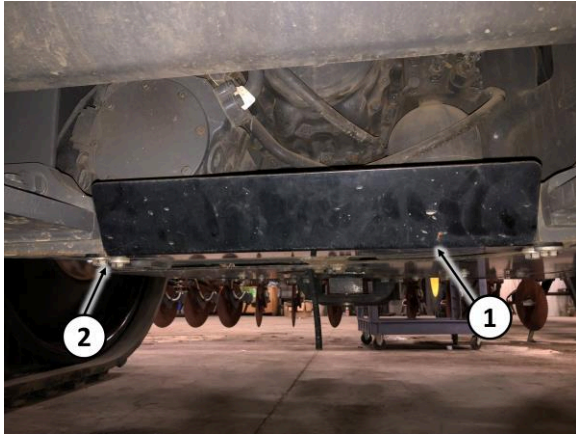

Install Rear Tank Supports

1. Install the right-hand tank mount (1) with three M16 x 40mm GR8.8 flange bolts (2). Refer to the [torque charts](#) in this Manual for bolt torque values.
2. Install the rubber isolator (3) with three 1/2" x 1-3/4" bolts (4), 1/2" washers, and center-lock nuts. Snug the bolts to slightly compress the rubber.

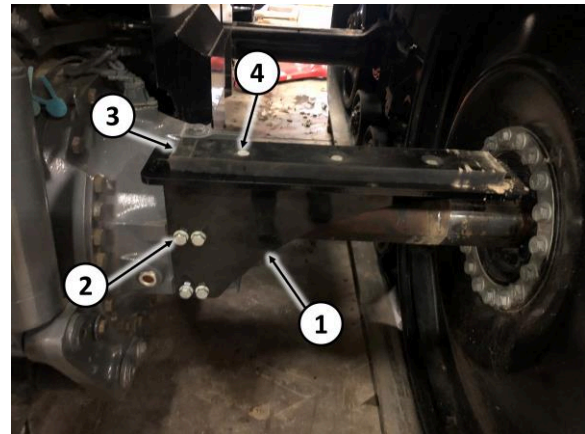

3. Repeat the procedure for the left-hand side.

Position the Tractor and Tanks

⚠ WARNING: Each tank weighs approximately 1100 lbs. Use an appropriate lifting device to prevent injury.

1. Raise the front of the tractor with an appropriate lifting device (1).
 - a. The suspension should be at maximum travel upwards, i.e., the front of the tracks should almost come off the ground.
 - b. This is meant to create clearance between the exhaust bracket casting and the suspension hard-bar.
2. Connect an appropriate lifting device to the right-hand tank.
3. Raise the tank (2) and guide it into position onto its support bracketry.



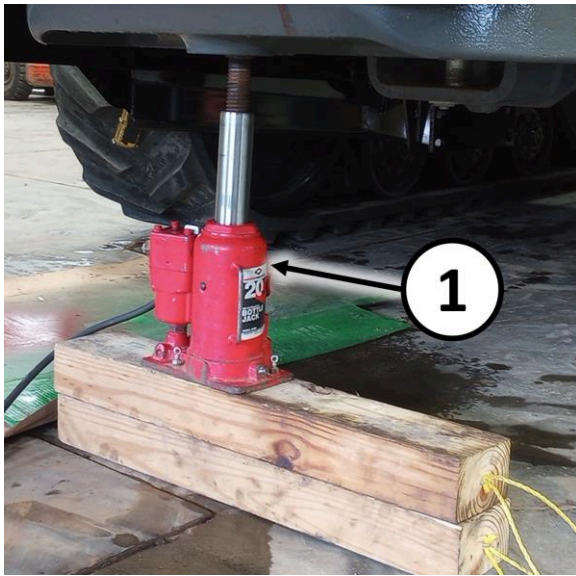

Install Underside Supports

⚠ WARNING: Frame bracketry weighs approximately 300 lbs. Use an appropriate lifting device to prevent injury.

1. Install the right-hand underside support (2) onto the receiver mounting bracket (1) with four 3/4" x 2-1/2" GR8 flange bolts (3) and flange nuts and four 3/4" x 2" GR8 flange bolts (4) and flange nuts. Refer to the [torque charts](#) in this Manual for bolt torque values.

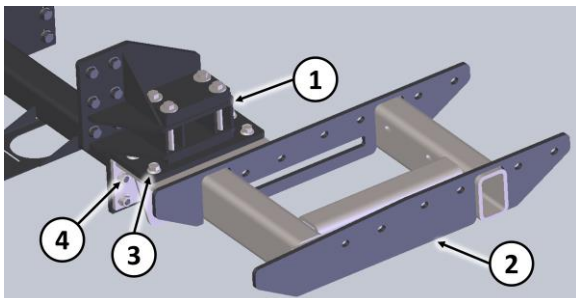

2. Add the intermediary bolt bracket (5) to the right-hand underside support (2). Position it with four 3/4" x 2" GR8 flange bolts and flange nuts (6). Do not tighten them yet.

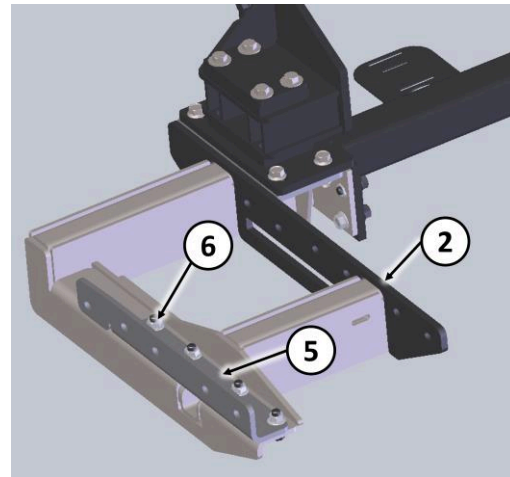

3. Repeat the procedure for the left-hand side.
4. Align the tank receiver with the underside support and install ten 3/4" x 2" GR8 flange bolts (7) with flange nuts and two 1/2" x 5-1/2" bolts, washers, and nuts (8).
5. Tighten all fasteners. Refer to [torque charts](#) in this instruction set for bolt torque values.

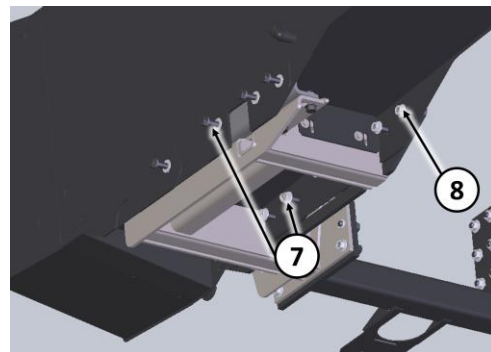

6. Repeat the procedure with the left-hand tank (9).



7. Disconnect the lifting devices.

Install Straps and Nylon Protector

1. Position the straps (1) into place and insert its studs through the holes in the tank supports. Install one each 3/8" x 1" G5 bolts and nuts (2) and 1/2" flange nut (3).

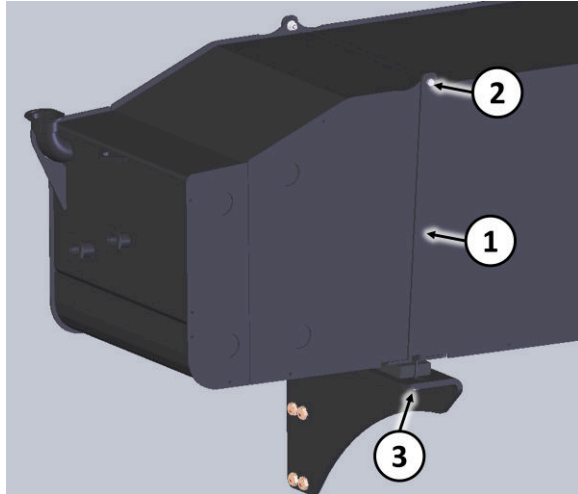

2. Repeat the procedure on the left-hand side.

Install Step Assembly

⚠ WARNING: Step assembly weighs approximately 300 lbs. Use an appropriate lifting device to remove step assembly.

1. Install the top bracket platform (1) onto the tractor above the left-hand tank with existing hardware (2).

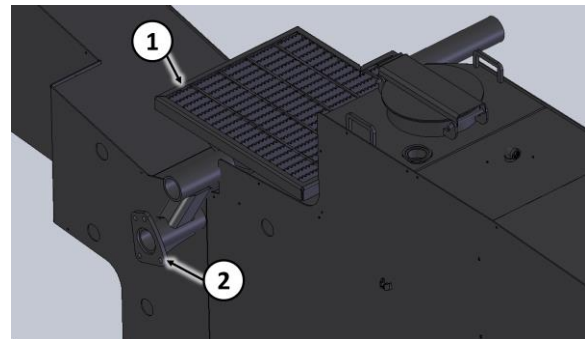

2. Install the base step (3) with four 5/8" x 2" GR8 flange bolts and flange nuts (4). Refer to [torque charts](#) in this instruction set for all bolt torque values.

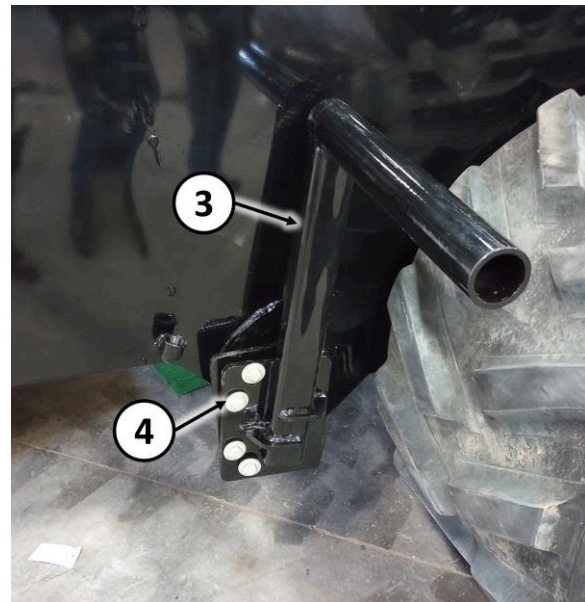

3. Attach a lifting device to the Step Assembly.
4. Install the step assembly (5) as shown into its receiver and tighten its setscrews (6).

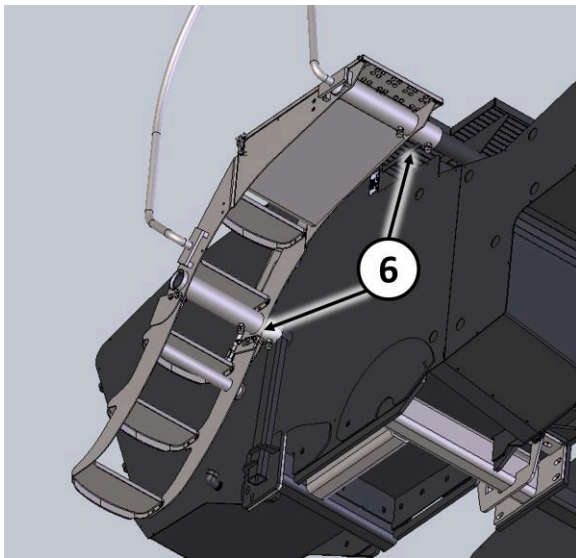
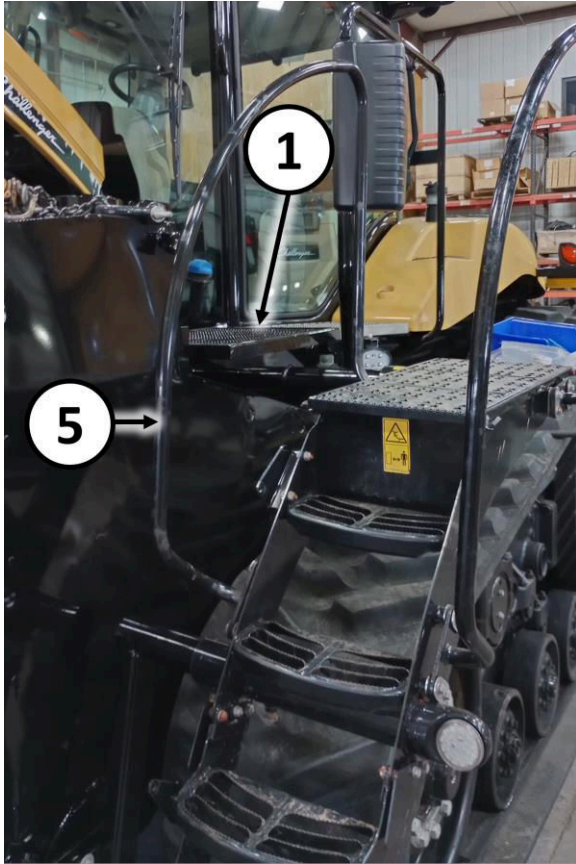

Install Plumbing Components

1. Install all plumbing components as shown in the [PARTS](#) section(s).

5. Install the [barrier chain](#) between the Step Assembly and the existing platform's rails.

PARTS

Tanks & Plumbing

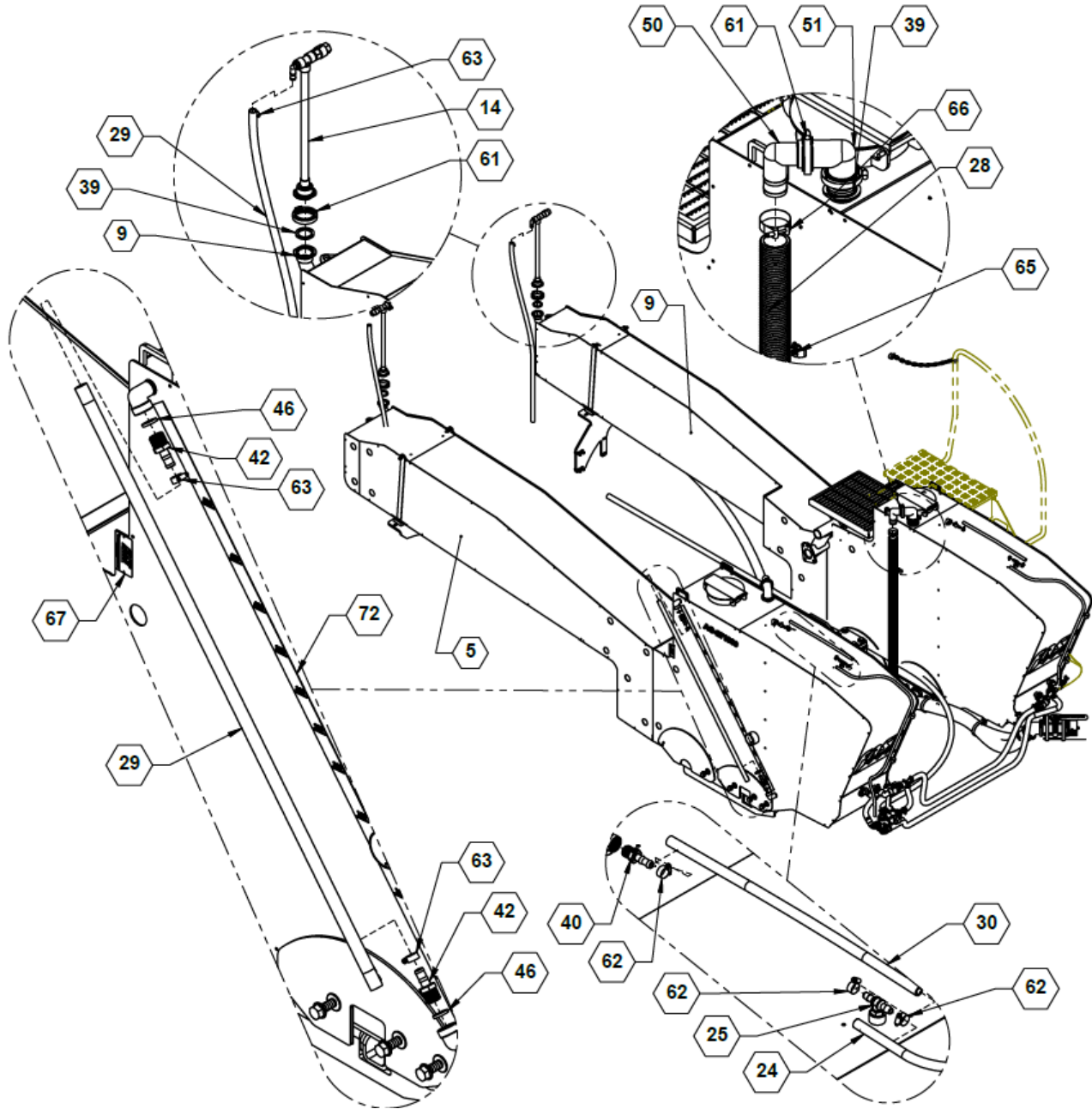

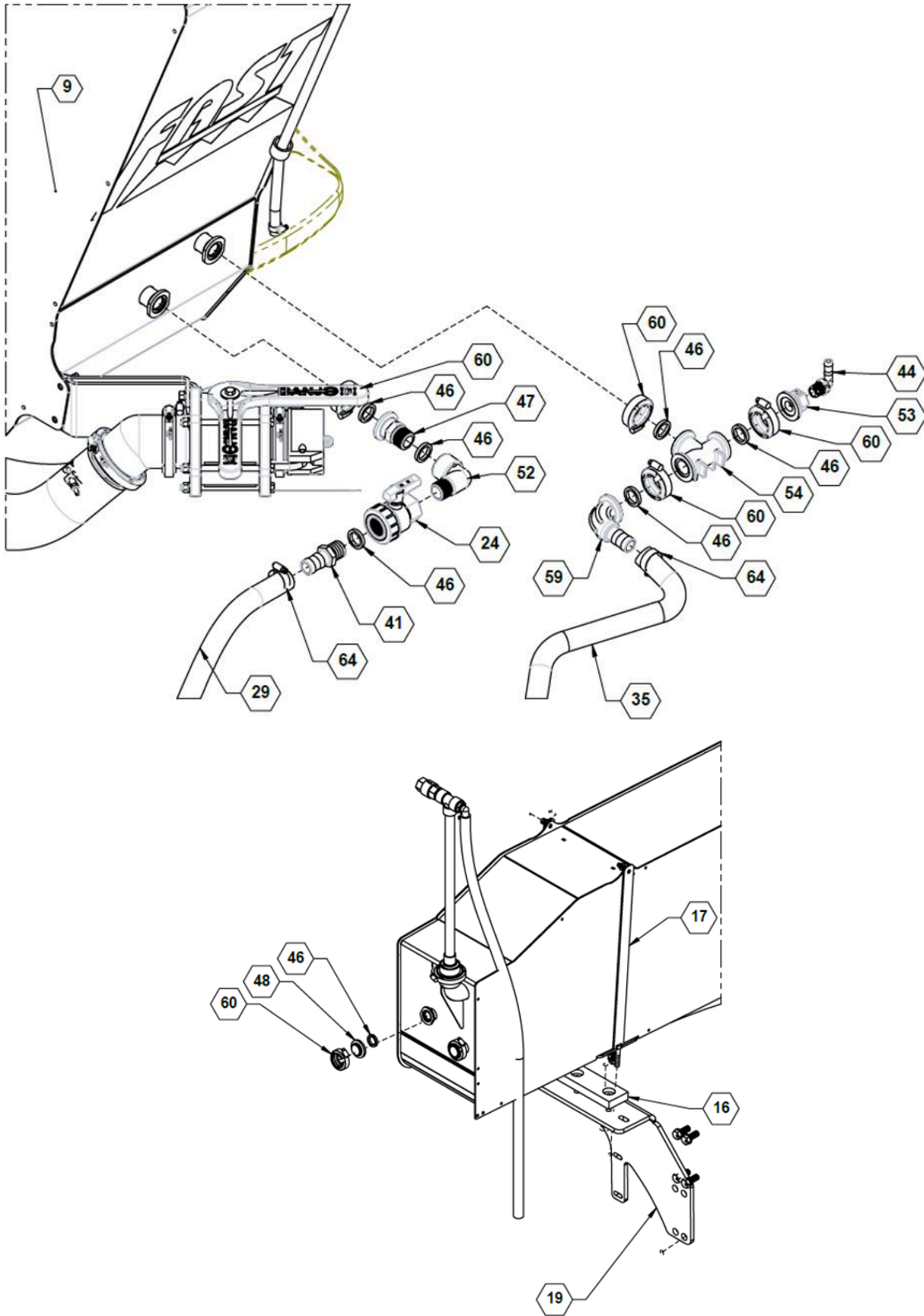

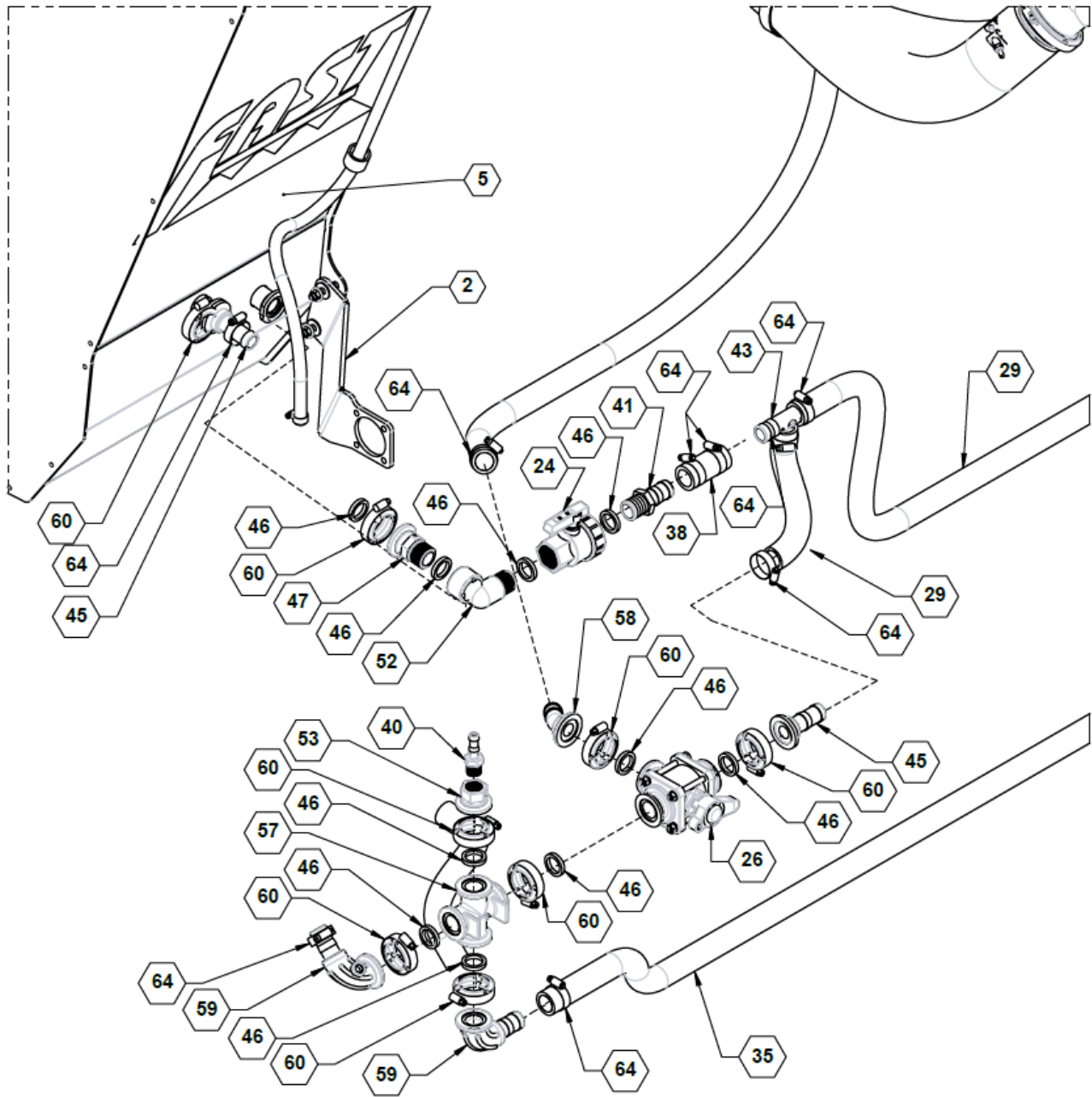

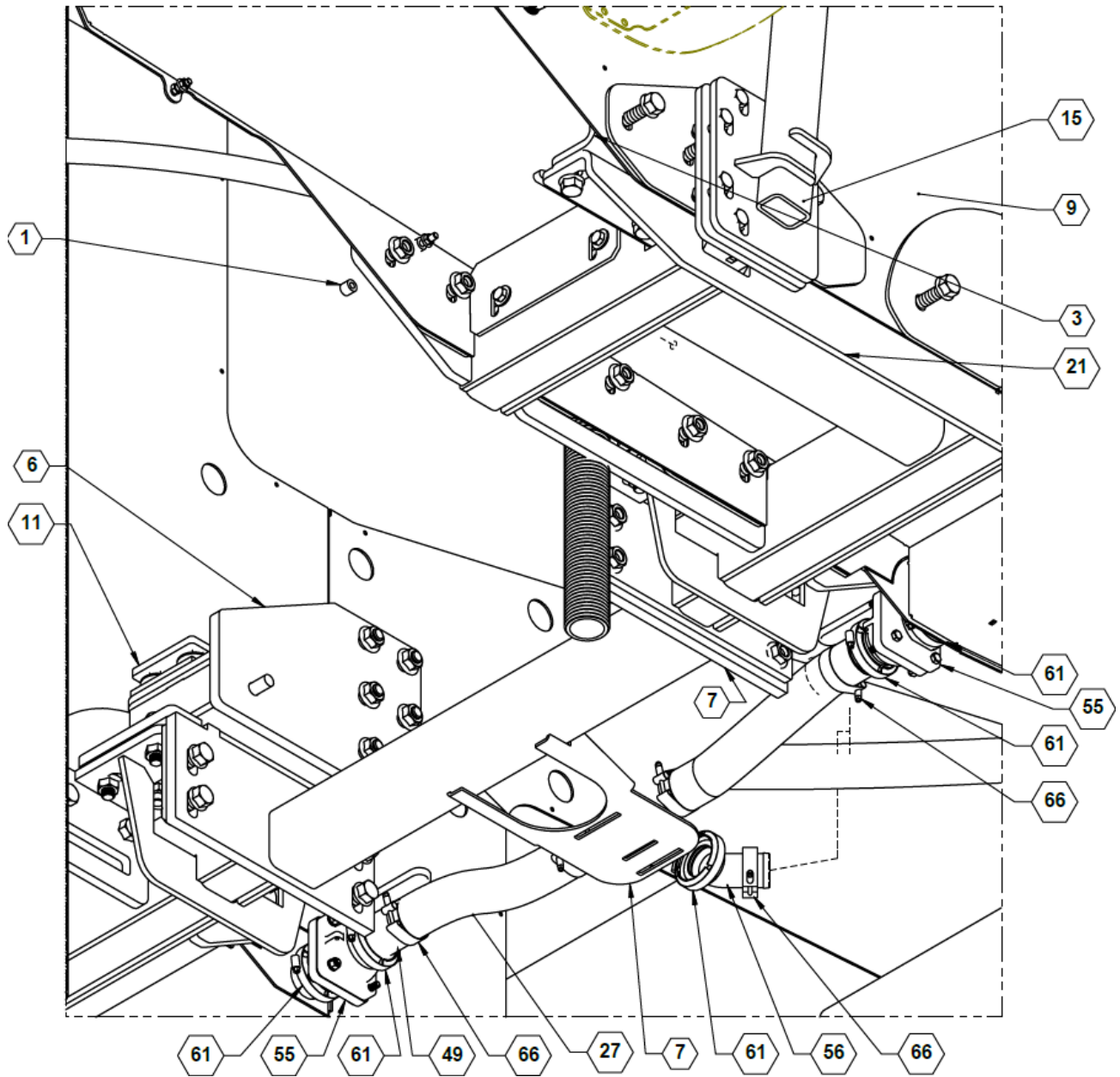

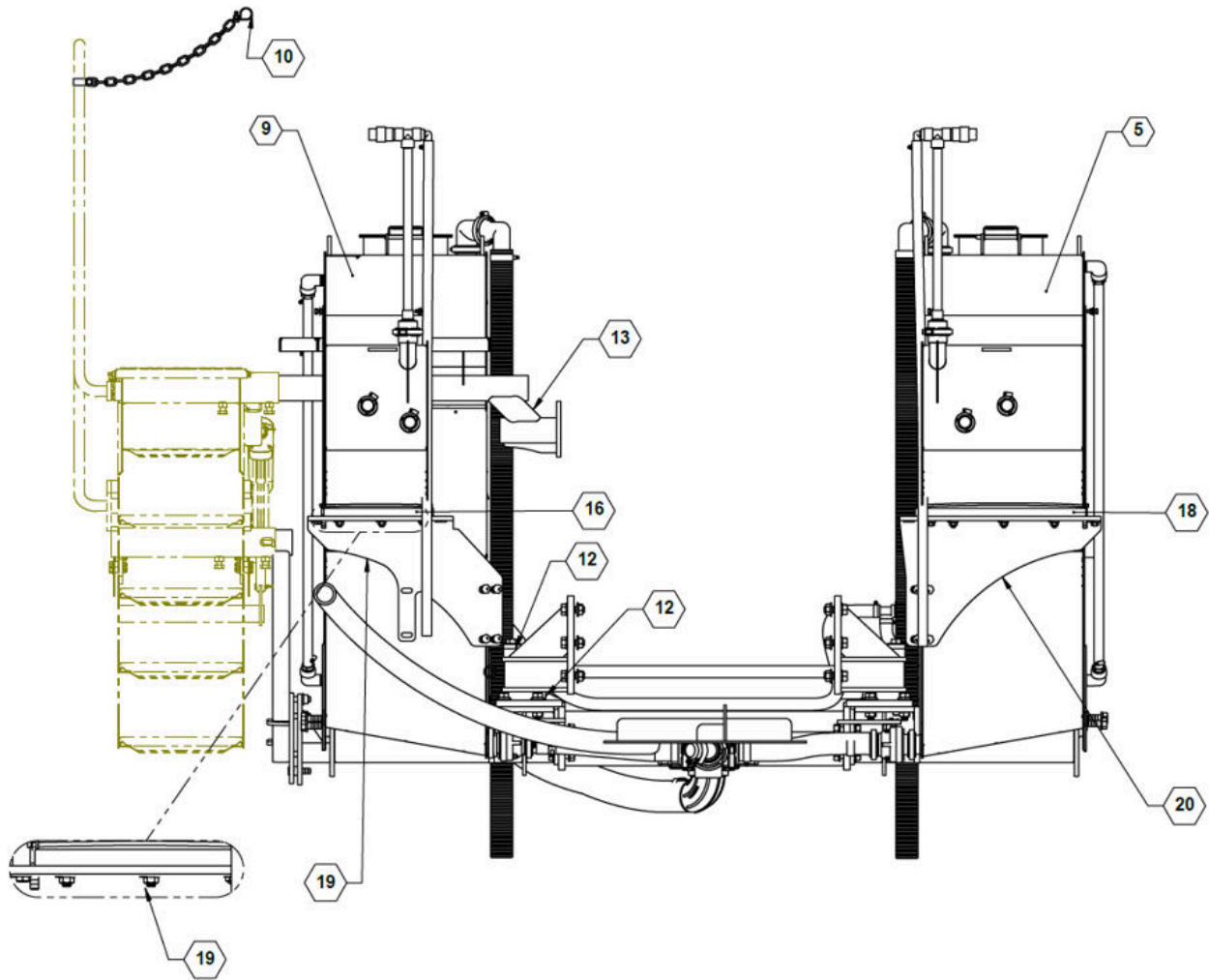



INSTALLATION & PARTS

Parts List 35500: Tanks & Plumbing

ITEM	PART	QTY	DESCRIPTION
1	15566	1	SPACER, HOSE BRACKET
2	25027	1	BRACKET, VALVE MOUNT
3 / 4	34659L / R	1 EA.	PLATE, BOLT ADAPT LEFT / RIGHT
5	34901	1	WELDMENT, RH TANK
6	34949	1	WLDMNT, RH FRONT MNT
7	34954	1	WLDMNT, CENTER TUBE
8	34957	1	WLDMNT, LH FRONT MNT
9	34964	1	WLDMNT, LH TANK
10	35104	1	ASSY, BARRIER CHAIN
11	35148	2	PLATE, FRONT BOLT
12	35149	4	RUBBER, FRONT ISOLATOR
13	35180	1	WLDMNT, REAR LADDER
14	35190	2	ASSY, SS RISER
15	35195	1	WELDMENT, FRONT LADDER
16	35196	1	BUMPER, REAR TANK
17	35197	4	WLDMNT, TANK HOLDDOWN
18	35199	1	RUBBER, RH TANK BUMPER
19	35236	1	PLATE, LH REAR SUPPORT
20	35237	1	PLATE, RH REAR SUPPORT
21	35298	1	WELDMENT, CENTER SUPPORT
22	35299	1	WELDMENT, CENTER SUPPORT R
23	35413	1	FENDT RADAR BRACKET/DEFLECTOR
24	500009	2	VALVE, 1.00 FULL PORT SINGLE UNION
25	500065	2	TEE, .50 MPT X .50 HB
26	500075	1	VALVE, 1.00 MANIFOLD, 3-WAY BOTTOM LOAD
27	510003	33 FT	HOSE 2" FERTILIZER
29	510006	20 FT	HOSE VINYL CLEAR 3/4 IN
30	510012	16 FT	HOSE 1/2 IN EPDM
35	510016	34 FT	HOSE, 1 IN EPDM
39	530019	11	GASKET, 2.00 EPDM
40	530035	3	STRAIGHT, 1/2 MPT 1/2" HB
41	530041	2	FITTING, 1.00 MNPT X 1.00 HB, POLY



INSTALLATION & PARTS

ITEM	PART	QTY	DESCRIPTION
42	530043	4	FITTING, 1.00 MPT X .75 HB
43	530056	1	FITTING, TEE, 1.00 HB, POLY
44	530059	1	ELBOW 90, .50 MPT X .50 HB, POLY
45	530066	2	FITTING, 1.00 MANIFOLD X 1.00 HB
46	530068	26	GASKET, 1.00 EPDM
47	530069	2	FITTING, 1.00 MANIFOLD X 1.00 MPT
48	530070	4	PLUG, MANIFOLD, 1.00
49	530103	2	FITTING, 2.00 FP FLANGE X 2.00 HB
50	530104	2	MANIFOLD, 2" FP X 2" HB 90~
51	530106	2	MANIFOLD COUPLING 90° 2" FP
52	530152	2	ELBOW 90, 1.00 STREET
53	530265	2	FITTING, 1.00 MANIFOLD X .50 FPT
54	530298	1	MANIFOLD TEE, 1"
55	530327	2	VALVE, 2.00 FP MANIFOLD, STUBBY
56	530354	1	ELBOW 45, 2.00 MANIFOLD X 2.00 HB
57	530413	1	CROSS FITTING, 1.00
58	530426	1	ELBOW 45, 1.00 FLANGE X 1.00 HB
59	530445	3	FLANGE SWEEP X 1 IN HB
60	540000	16	CLAMP, WORM SCREW, 1.00
61	540002	11	CLAMP, FP WORM SCREW, 2.00
62	540012	8	HOSE CLAMP, SS 1/2" #12
63	540013	6	HOSE CLAMP, SS .75 #12
64	540014	11	HOSE CLAMP, SS 1.00 #16
65	540051	2	P-CLAMP, 2" W/3/8" HOLE
66	540069	7	HOSE CLAMP, 2.00 T-BOLT
67	590216	2	FAST SERIAL TAG
68	590892	1	KIT, HARDWARE, FENDT TRACK TANKS
69	740071	2	4 PIN DEUTSCH EXTENSION 60"
70	740072	2	4 PIN DEUTSCH EXTENSION 60"
71	800079	2	FAST TANK LOGO
72	800351	1	DECAL, RH GALLON MARKER
73	800352	2	DECAL, TANK AG-2T1000
74	800353	1	DECAL, LH GALLON MARKER

Barrier Chain

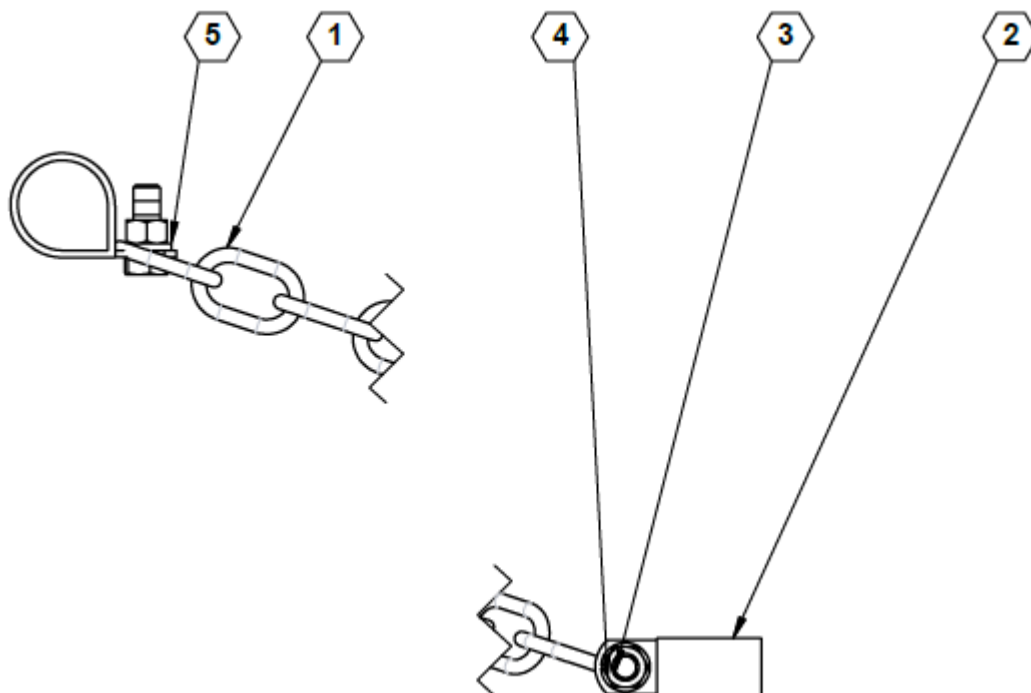

Parts List 35104: Barrier Chain

ITEM	PART NO.	QTY.	DESCRIPTION
1	35133	1	CHAIN, STRAIGHT LINK
2	540035	2	P-CLAMP, 1-1/4"
3	128	2	BOLT, HH 3/8-16 X 1 GR5 ZINC
4	213	2	NUT, HEX 3/8-16 ZINC
5	250	2	LOCKWASHER, 3/8 ZINC

F/C SS Riser

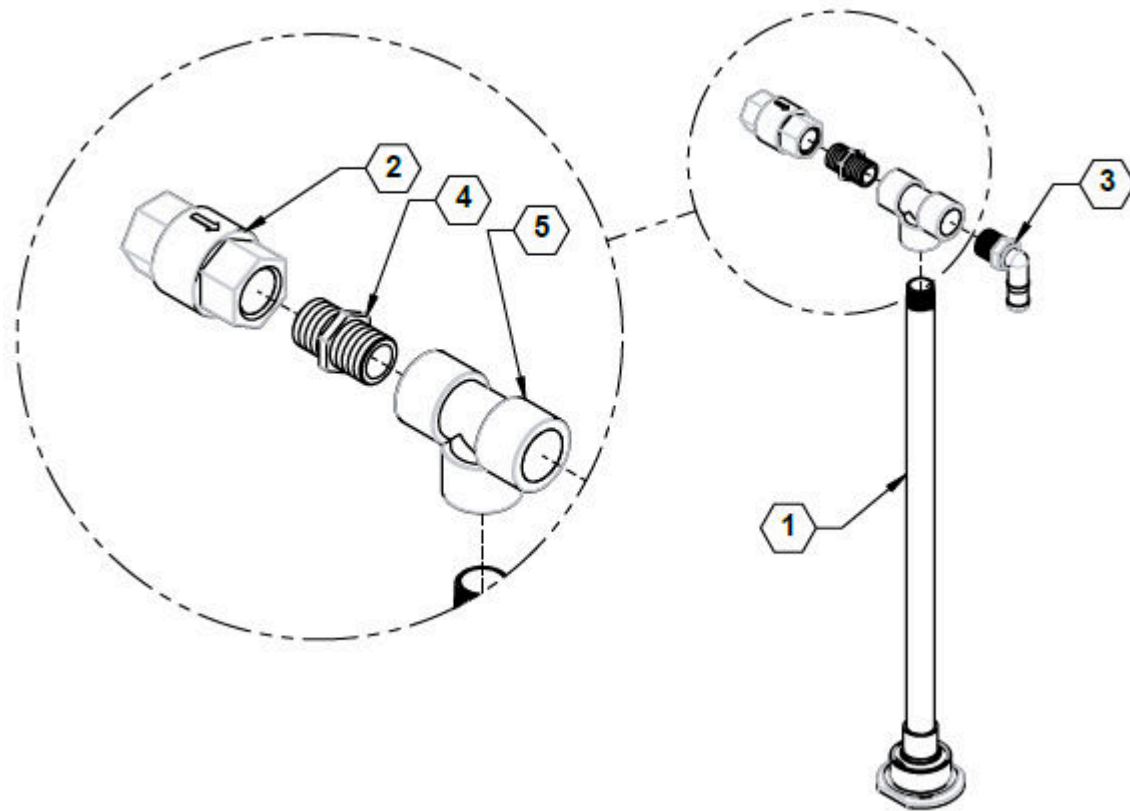

NOTE: APPLY THREAD SEALANT TO ALL THREADED CONNECTIONS BEFORE ASSEMBLY

Parts List 35190: F/C SS Riser

ITEM	PART NO.	QTY.	DESCRIPTION
1	35189	1	WLDMNT, REAR TANK SS RISER
2	500014	1	CHECK VALVE, .75 VITON F, POLY
3	530040	1	HOSE SHANK, 3/4" MPT X 3/4" HB 90~
4	530131	1	NIPPLE, POLY PIPE 3/4" SHORT
5	530156	1	TEE, 3/4" POLY PIPE

Quick Fill, 2"

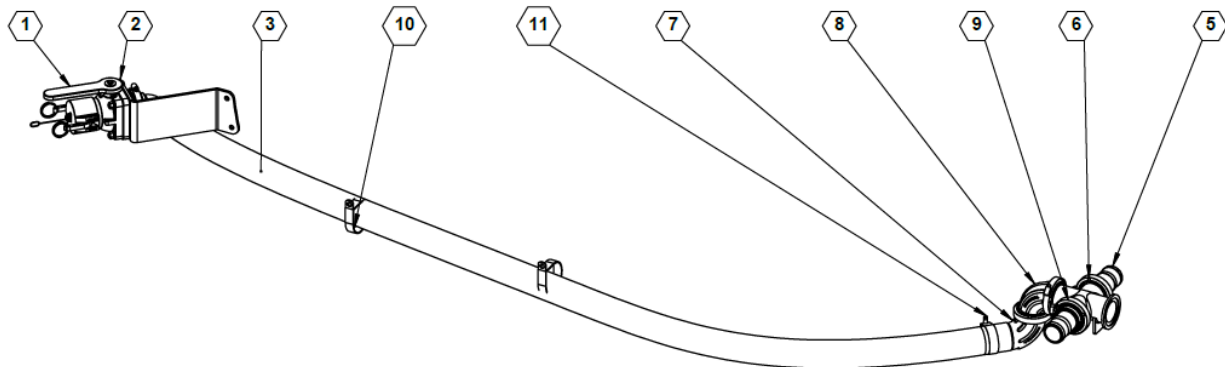

Parts List 35254: Quick Fill, 2"

ITEM	PART NO.	QTY.	DESCRIPTION
1	90SA2QF45	1	ASSY, 2.00 45 DEG QUICK FILL VALVE
2	10206	1	BRACKET, 2.00 QUICK FILL MOUNT
3	510003	1	HOSE, 2" FERTILIZER
4	530019	4	GASKET, 2.00 EPDM
5	530103	2	FITTING, 2.00 FP FLANGE X 2.00 HB
6	530107	1	CROSS, 2.00 FULL PORT
7	530334	1	2" FP PLANGE X HOSE SHK SWEEP
8	530386	1	MANIFOLD SWEEP, 2" FP FLANGE
9	540002	4	CLAMP, FP WORM SCREW, 2.00
10	540052	2	P-CLAMP, 3" W/3/8" HOLE
11	540069	2	HOSE CLAMP, 2.00 T-BOLT

Quick Fill, 3"

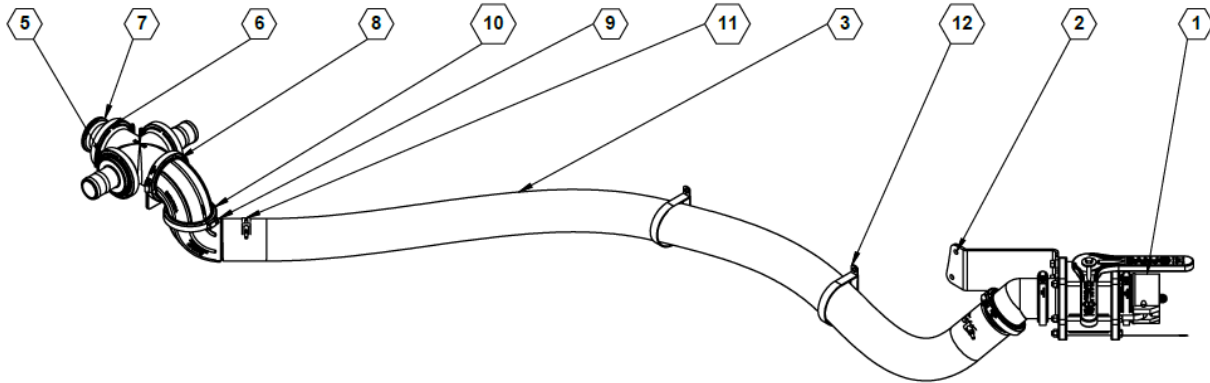

Parts List 35255: Quick Fill, 3"

ITEM	PART	QTY.	DESCRIPTION
1	90SA3QF45	1	3" QUICK FILL VALVE @ 45°
2	35263	1	PLATE, 3" QUICK FILL MOUNT
3	510038	10 FT	HOSE, 3" FERTILIZER BLACK
4	530024	5	GASKET, 3" EPDM
5	530111	2	MANIFOLD, 3" X 2" HB
6	530297	1	Flanged Cross 3 Inch
7	530316	1	MANIFOLD REDUCER 3" X 2" CPLR
8	530439	1	MANIFOLD SWEEP, FLANGE 3"
9	530441	1	FLANGE SWEEP, 90 X 3" HOSE BARB
10	540003	5	CLAMP, WORM SCREW 3"
11	540027	2	CLAMP, HOSE 3" T-BOLT
12	540053	2	P-CLAMP, 4" W/3/8" HOLE

Hardware

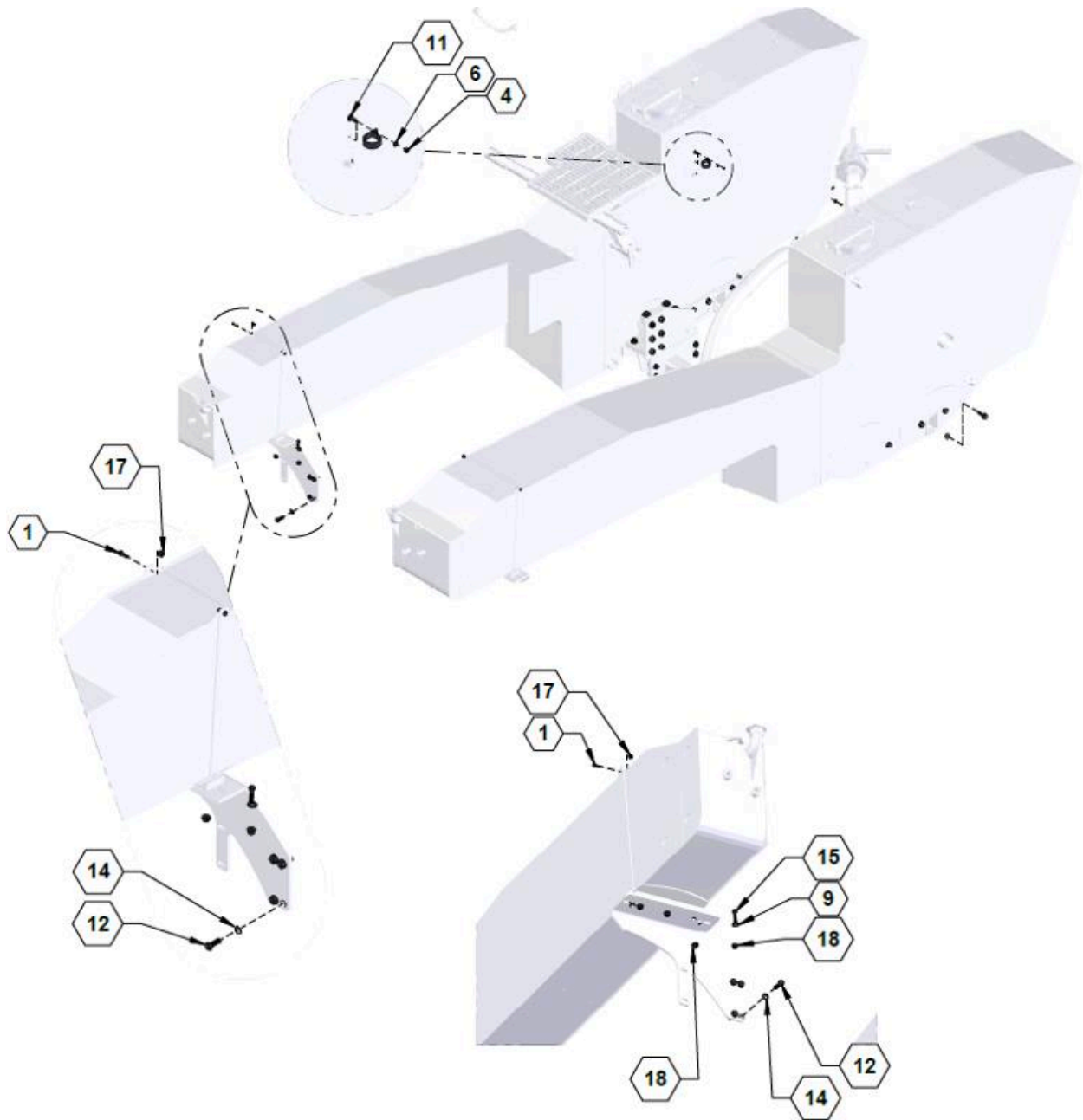

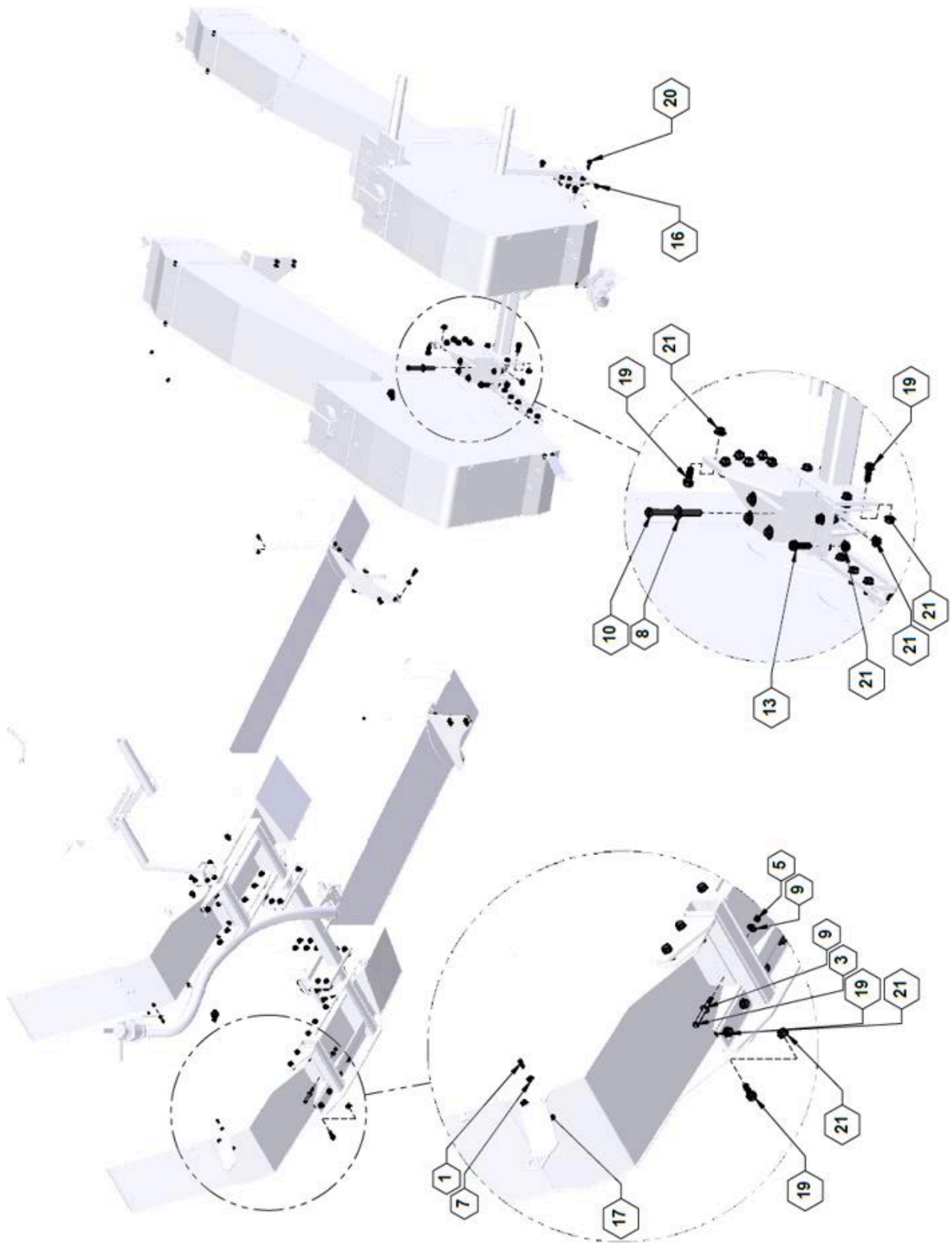

Parts List 590892: Hardware

ITEM	PART NO.	QTY.	DESCRIPTION
1	128	9	BOLT, HH 3/8-16 X 1 GR5 ZINC
2	130	1	BOLT, HH 3/8-16 X 2 GR5 ZP
3	161	4	BOLT, HH1/2-13 x 5 1/2"
4	213	2	NUT, HEX 3/8-16 ZINC
5	239	4	NUT, CENTER LOCK, 1/2-13 GR5 ZP
6	250	2	LOCKWASHER, 3/8 ZINC
7	258	4	WASHER, FLAT 3/8 ZINC
8	262	8	WASHER, FLAT 3/4 ZINC
9	260	14	WASHER, FLAT, 1/2 ZINC
10	488	8	BOLT, 3/4-10 X 8-1/2" Gr5 ZP
11	592	2	BOLT, CARRIAGE 3/8-16 X 1 ZINC
12	596595M	8	BOLT, HH, M16 X 40MM GR 8.8 MAGNI
13	596603M	8	BOLT, FLANGE 3/4"-10 X 2.5" GR. 8 MAGNI
14	596627M	8	WASHER, FLAT, 16MM, MAGNI
15	603	6	BOLT, HH 1/2-13 X 1-3/4 GR5 ZINC
16	590189	4	NUT, FLANGE TOPLOCK 5/8" GR G
17	769	10	NUT, 3/8-16 WHIZLOCK, ZP
18	771	10	1/2" FLANGE NUT ZP
19	596814M	48	BOLT, HEX FLANGE 3/4-10 X 2 GR8 MAGNI
20	596831M	4	BOLT, FLANGED 5/8-11 X 2" GR8 MAGNI
21	773	64	3/4-10 Whiznut

TORQUE SPECIFICATIONS

Check the tightness of ALL BOLTS, U-BOLTS, and CAP SCREWS after the first 10-15 hours of operation and again at end of the first week (50 hours) of operation. Tighten all bolts to torques specified unless otherwise noted. Check tightness of hardware periodically.

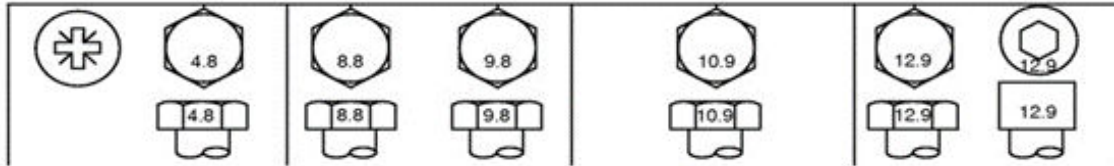

Figure 2: Common metric bolt grade markings

Metric Bolt and Screw Torque Values

Screw Size	Class 4.8				Class 8.8 or 9.8				Class 10.9				Class 12.9			
	Lubricated ¹		Dry ²		Lubricated ¹		Dry ²		Lubricated ¹		Dry ²		Lubricated ¹		Dry ²	
	N-m	lb.-in.	N-m	lb.-in.	N-m	lb.-in.	N-m	lb.-in.	N-m	lb.-in.	N-m	lb.-in.	N-m	lb.-in.	N-m	lb.-in.
M6	4.7	42	6	53	8.9	79	11.3	100	13	115	16.5	146	15.5	137	19.5	172
									N-m	lb.-ft.	N-m	lb.-ft.	N-m	lb.-ft.	N-m	lb.-ft.
M8	11.5	102	14.5	128	22	194	27.5	243	32	23.5	40	29.5	37	27.5	47	35
			N-m	lb.-ft.	N-m	lb.-ft.	N-m	lb.-ft.								
M10	23	204	29	21	43	32	55	40	63	46	80	59	75	55	95	70
	N-m	lb.-ft.														
M12	40	29.5	50	37	75	55	95	70	110	80	140	105	130	95	165	120
M14	63	46	80	59	120	88	150	110	175	130	220	165	205	150	260	190
M16	100	74	125	92	190	140	240	175	275	200	350	255	320	235	400	300
M18	135	100	170	125	265	195	330	245	375	275	475	350	440	325	560	410
M20	190	140	245	180	375	275	475	350	530	390	675	500	625	460	790	580
M22	265	195	330	245	510	375	650	480	725	535	920	680	850	625	1080	800
M24	330	245	425	315	650	480	820	600	920	680	1150	850	1080	800	1350	1000
M27	490	360	625	460	950	700	1200	885	1350	1000	1700	1250	1580	1160	2000	1475
M30	660	490	850	625	1290	950	1630	1200	1850	1350	2300	1700	2140	1580	2700	2000
M33	900	665	1150	850	1750	1300	2200	1625	2500	1850	3150	2325	2900	2150	3700	2730
M36	1150	850	1450	1075	2250	1650	2850	2100	3200	2350	4050	3000	3750	2770	4750	3500

Torque values listed are for general use only, based on the strength of the bolt or screw. DO NOT use these values if a different torque value or tightening procedure is given for a specific application. For stainless steel fasteners or for nuts on U-bolts, see the tightening instructions for the specific application. Tighten plastic insert or crimped steel type lock nuts by turning the nut to the dry torque shown in the chart, unless different instructions are given for the specific application.

Shear bolts are designed to fail under predetermined loads. Always replace shear bolts with identical property class. Replace fasteners with the same or higher property class. If higher property class fasteners are used, tighten these to the strength of the original. Make sure fastener threads are clean and that you properly start thread engagement. When possible, lubricate plain or zinc plated fasteners other than lock nuts, wheel bolts, or wheel nuts, unless different instructions are given for the specific application.

¹ "Lubricated" means coated with a lubricant such as engine oil, fasteners with phosphate and oil coatings, or M20 and larger fasteners with JDM F13C, F13F or F13J zinc flake coating.

² "Dry" means plain or zinc plated without any lubrication, or M6 to M18 fasteners with JDM F13B, F13E or F13H zinc flake coating.

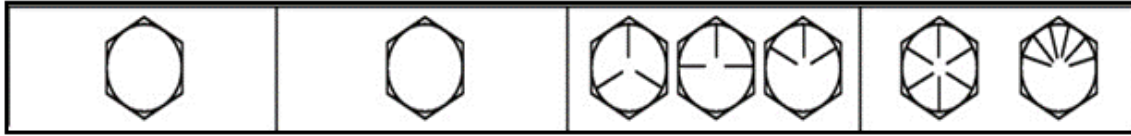

Figure 3: Common imperial bolt grade markings

Unified Inch Bolt and Screw Torque Values

Screw Size	SAE Grade 1				SAE Grade 2 ³				SAE Grade 5, 5.1 or 5.2				SAE Grade 8 or 8.2			
	Lubricated ⁴		Dry ⁵		Lubricated ⁴		Dry ⁵		Lubricated ⁴		Dry ⁵		Lubricated ⁴		Dry ⁵	
	N-m	lb.-in.	N-m	lb.-in.	N-m	lb.-in.	N-m	lb.-in.	N-m	lb.-in.	N-m	lb.-in.	N-m	lb.-in.	N-m	lb.-in.
1/4	3.7	33	4.7	42	6	53	7.5	66	9.5	84	12	106	13.5	120	17	150
													N-m	lb.-ft.	N-m	lb.-ft.
5/16	7.7	68	9.8	86	12	106	15.5	137	19.5	172	25	221	28	20.5	35	26
									N-m	lb.-ft.	N-m	lb.-ft.				
3/8	13.5	120	17.5	155	22	194	27	240	35	26	44	32.5	49	36	63	46
			N-m	lb.-ft.	N-m	lb.-ft.	N-m	lb.-ft.								
7/16	22	194	28	20.5	35	26	44	32.5	56	41	70	52	80	59	100	74
	N-m	lb.-ft.														
1/2	34	25	42	31	53	39	67	49	85	63	110	80	120	88	155	115
9/16	48	35.5	60	45	76	56	95	70	125	92	155	115	175	130	220	165
5/8	67	49	85	63	105	77	135	100	170	125	215	160	240	175	305	225
3/4	120	88	150	110	190	140	240	175	300	220	380	280	425	315	540	400
7/8	190	140	240	175	190	140	240	175	490	360	615	455	690	510	870	640
1	285	210	360	265	285	210	360	265	730	540	920	680	1030	760	1300	960
1-1/8	400	300	510	375	400	300	510	375	910	670	1150	850	1450	1075	1850	1350
1-1/4	570	420	725	535	570	420	725	535	1280	945	1630	1200	2050	1500	2600	1920
1-3/8	750	550	950	700	750	550	950	700	1700	1250	2140	1580	2700	2000	3400	2500
1-1/2	990	730	1250	930	990	730	1250	930	2250	1650	2850	2100	3600	2650	4550	3350

Torque values listed are for general use only, based on the strength of the bolt or screw. DO NOT use these values if a different torque value or tightening procedure is given for a specific application. For plastic insert or crimped steel type lock nuts, for stainless steel fasteners, or for nuts on U-bolts, see the tightening instructions for the specific application.
 Shear bolts are designed to fail under predetermined loads.
 Always replace shear bolts with identical grade.

Replace fasteners with the same or higher grade. If higher grade fasteners are used, tighten these to the strength of the original. Make sure fastener threads are clean and that you properly start thread engagement. When possible, lubricate plain or zinc plated fasteners other than lock nuts, wheel bolts, or wheel nuts, unless different instructions are given for the specific application.

³ Grade 2 applies for hex cap screws (not hex bolts) up to 6 in. (152 mm) long. Grade 1 applies for hex cap screws over 6 in. (152 mm) long, and for all other types of bolts and screws of any length.

⁴ "Lubricated" means coated with a lubricant such as engine oil, fasteners with phosphate and oil coatings, or 7/8 in. and larger fasteners with JDM F13C, F13F or F13J zinc flake coating.

⁵ "Dry" means plain or zinc plated without any lubrication, or 1/4 to 3/4 in. fasteners with JDM F13B, F13E or F13H zinc flake coating.



Fast Ag Solutions
4130 Commerce Boulevard
Windom, MN 56101

1-800-772-9279 Toll Free

1-507-427-3861 Voice

1-507-427-3030 Fax

<https://fastagsolutions.com/>