



A18-60'/66' and A26-60'/66' QUICK SETUP GUIDE

Refer to Operators Manual for Complete Setup Instructions

<https://www.youtube.com/watch?v=YCYqRj-eGIA>

Set Up Tractor Hydraulics - All Machines

Important: Check hydraulic oil level. Fill if necessary. Set SCV flow rates and detent times as shown in table.

SCV	Function	Flow	Detent Time
I	Main Lift/Lower/ Down-Pressure	10	Continuous
II	Toolbar Fold/Unfold	10	Continuous
III	Pump	7-8	Continuous
IV	Steerable Hitch (if equipped)	1-2	Continuous

Unfolding the Toolbar -- from Transport Position to Field Position

- Pulling rearward on SCV I raise center section and inner wings and visually verify the toolbar is fully raised
- Push SCV II forward to detent in continuous mode
- Disengage transport latches by holding latches switch in transport position until completely disengaged
- Unfold toolbar by holding main wings switch in field position until wings are unfolded. Wings will be in line with center section when fully unfolded
- Engage main wing latches by holding latches switch in field position until wing latches are fully engaged
- Hold flip wings switch in field position to unfold the flip wings
- Disengage SCV II and remove transport cylinder locks from both main lift cylinders

Folding the Toolbar -- from Field Position into Transport Position

- Pulling rearward on SCV I raise center section and inner wings and visually verify the toolbar is fully raised
- Push SCV II forward to detent in continuous mode
- Hold flip wings switch in transport position to fold the flip wings
- Disengage wing latches by holding latches switch in transport position until completely disengaged
- Fold toolbar by holding main wings switch in transport position until main wings are seated in transport rest at the rear of the machine
- Engage transport latches by holding latches switch in field position until they fully engage inner wings
- Disengage SCV II and install transport cylinder locks on both main lift cylinders

Adjust Center Section Height

- Place machine on level surface in field
- Unfold toolbar and lower until coulter blades are 2-4" in the ground
- Install required number of depth stops (A) on main lift cylinders to set the center section to desired depth
- While applying fertilizer, operate SCV I in continuous down mode. This will keep the center section against the depth stops and supply oil to the down pressure valve(s)

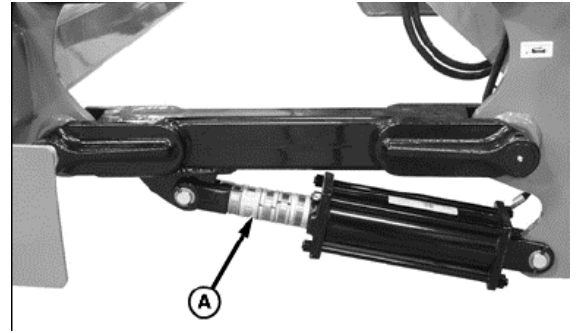

Adjust Gauge Wheel Height

- With center section height set, adjust the inner and outer gauge wheels so that the coulter blades are 2-4" in the ground
- Adjust gauge wheel (B) by removing spring clip (D) and retaining pin (C) and moving the gauge wheel up or down
- Reinstall pin and retaining clip

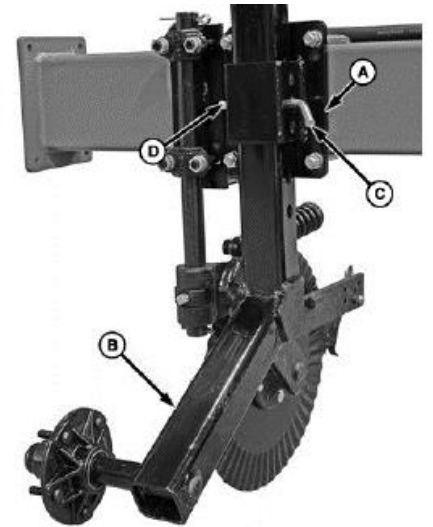

Set Toolbar Main Wing and Flip Wing Down-Pressure (If Equipped)

Important: Toolbar down pressure should read between 700 - 1000 psi but can be adjusted from 0 - 1500psi. Down pressure should not exceed 1500 psi. See pressure gauge (D). Do not use more down-pressure than necessary or excessive wear and damage to machine could result.

- Adjust down-pressure to initial setting by rotating knob (E) on Main Wing down pressure valve (G). Tighten to increase pressure, loosen to decrease pressure.
- Once set, lock knob in position with collar (F)
- Make a trial pass in field. If coulter to ground engagement is not satisfactory, adjust hydraulic pressure as needed
- If equipped, use Flip Wing down pressure valve (H) in the same manner to adjust Flip Wing down pressure.

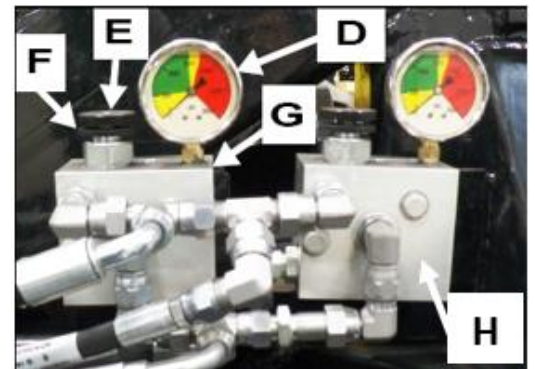

Product Plumbing Setup and Calibration

- Refer to Operators Manual for complete product plumbing setup, calibration, and servicing.